



A.M.P-Rose



A.M.P-Rose

Your partner in the confectionery industry

Established over 35 years ago, A.M.P-Rose is one of the world's leading suppliers of machines to the chocolate and confectionery industries. We specialize in the design and manufacture of processing and packaging machines, with 80% of our products being exported to more than 80 countries world-wide. We supply new as well as used and rebuilt machinery.

The Company currently employs over 150 people in two well-equipped, modern facilities, a 100,000 sq/ft factory in Gainsborough, England, and a factory in Bangalore, India that was opened in 1995.

We provide local support by our network of Agents, so Clients can be assured of a prompt and high quality service wherever they are in the world.

Brief History

The 'Rose' name has been synonymous with the packaging industry since 1881, when William Rose formed Rose Brothers in Gainsborough. The very first machine that was built by William Rose was a tobacco wrapping machine, the first commodity to be mechanically wrapped for sale. He then took this knowledge to the confectionery, bakery, and tea industries.

A.M-Packaging Ltd began as a supplier of rebuilt candy wrapping machines in 1978. At that stage the company employed 4 engineers in a small engineering factory. The founder Mr Alan Mann had learned his trade as a Rose technician from the age of 16.

The business expanded to such an extent that in 1990 A.M-Packaging was able to purchase the Rose and Forgrove confectionery businesses and at that time re-named itself 'A.M.P-Rose'.

Since its humble beginnings the company has developed into one of the world's leading suppliers of machines to the chocolate and confectionery industries.

Milestones

- 1978** - A.M-Packaging formed by Alan Mann
- 1980** - First exported machine goes to South Africa
- 1984** - The company's first new machine 'ICW' cut and flowrap machine is launched
- 1988** - Workforce grows to 50 people
- 1990** - The Company acquires 'Rose Forgrove' confectionery division
- 1991** - Workforce expands to 100 people
- 1995** - Subsidiary 'AMP-Rose India' is formed
- 2001** - Launch of 26DM chocolate bunch wrapping machine, coating pans and range of laboratory scale equipment.
- 2005** - The Company supplies equipment for the 'Charlie & the Chocolate Factory' film
- 2008** - Construction begins on new 100,000sq/ft headquarters in Gainsborough
- 2014** - The first chocolate moulding line manufactured by A.M.P-Rose is installed in Thailand



William Rose



New Machinery

A.M.P-Rose designs and manufactures a wide range of new machinery from raw materials all the way through to the packaging of the product. Supplying single machines, full lines, or bespoke machinery.

Machinery supplied

- Cut and wrap machines
- Chocolate moulding lines
- Multipack feeding and packaging systems for snacks
- Hard candy cooking, forming and wrapping
- Lollipop equipment
- Caramel and toffee cooking
- Stickpack and roll-wrapping
- Chocolate processing
- Chocolate wrapping
- Batch rollers and rope sizers
- Sugar and chocolate coating machines
- Vertical and horizontal form, fill and seal machines, and multihead weighers
- Laboratory equipment



Rebuilt Machines

A.M.P-Rose name is world renowned for the supply of the highest quality rebuilt machines. The Company has an enviable reputation and a world-wide Blue Chip customer base.

Our technicians are experienced with many different brands of processing and packaging equipment, which allows us to supply almost any machine required in the candy and chocolate manufacturing processes.

The work undertaken to a fully rebuilt machine includes the following:

- Complete strip down to the bare frame
- Remove old paintwork and re-spray to desired colour
- Every component inspected and all damaged or faulty ones replaced or repaired
- Design and manufacture of new size-change parts
- Re-assembly by skilled, experienced technicians
- Completely new electrical wiring throughout
- New electrical panel and components
- Provision of guarding to meet current Health & Safety/CE standards
- Machine set-up and test-run using client's products and wrapping materials
- Supply of machine operator manuals and electrical wiring diagrams
- Installation, commissioning and training on-site



Used Equipment

A.M.P-Rose continues to be one of the worlds largest dealers in used candy and chocolate machinery. We have 100's of second hand machinery for many types of confectionery, chocolate, wafer and biscuit products in stock at our factory in Gainsborough.

We are always interested in buying used machinery, so if you have equipment you would like to sell let us know and we will be pleased to either make an offer for the outright purchase of it, or alternatively sell it on your behalf.



Workshop

The majority of parts required in our work are manufactured in our own workshops, which houses the following facilities;

- 2D and 3D CAD/CAM facility including solid modelling and advanced machine design software
- Component manufacturing using conventional and CNC machine tools
- Spare parts and after-sales service
- Spray painting and component finishing facilities
- Machine assembly areas for both processing and packaging machines
- Crate manufacturing, packing and dispatch departments
- Purchasing and planning departments using modern manufacturing software

Our electrical department uses tried and tested products thus ensuring reliability and fast and efficient spares replacement. Full wiring diagrams are provided with all new and rebuilt machines leaving our factory.

Our paint shop couples traditional methods with modern materials and technology thus giving the final finishing touch to all machines.

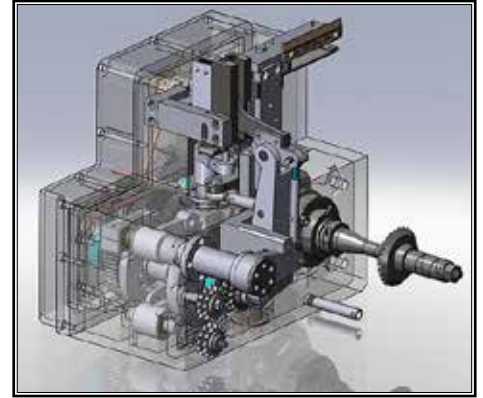

Spares and Service

For more than 35 years A.M.P-Rose has been supplying spare parts to the confectionery and chocolate industry. We supply genuine spare parts for all Rose, Forgrove and A.M.P-Rose confectionery and chocolate machines, as well as parts for many other makes of machines, including size-change parts, replacement knives, cams, gears and the like.

We also have skilled, experienced Service Engineers available for the installation and commissioning of confectionery packaging and processing machines, whether it is in England or abroad.



Size Change Parts

A.M.P-Rose regularly supplies size and style change sets for many different types of confectionery and chocolate wrapping machines. Such machines include:- SIG, Sapal, Rasch, Rose Theegarten, Autowrappers, Otto Hansel, GD, Nagema, Carle & Montanari, and all Rose & Forgrove chocolate and candy wrapping machines.

Spare Parts

We also supply spare parts such as replacement cams, gears, paper knives and general running spares for all of the above mentioned machinery, as well as;

- Forming dies and cams for Uniplast 160 A/B/C/D, Euromec, Strada, Baby and Super Rostoplast, 85A Super Robust, Aquarius RLM2 and RLM3 etc
- Cooking coils and bowls for Hamac 145A and 155 and Solvomat, Otto Hansel 1704, and Ter Braak TBK 750/1300,
- Replacement conical rollers and sizing rollers for Hamac, Rose, Guiseley and Euromec batch rollers and rope sizers
- Wire and plastic belts for Hamac, Guiseley, Euromec, Klockner cooling tunnels
- Plastic belts for DT&G belt type chocolate coaters



Special Services

Apart from its mainstream activities, AMP Rose is also able to provide the following services;

Asset Valuation and Disposal

Our staff can provide current market valuations for all of your chocolate, candy and gum production and packaging machinery, whether it is for in-house use, insurance purposes or for disposal. If required we can arrange for the disposal of assets by various means;

Public Auction

Private sale ex site

Removal, storage and sale

Plant decommissioning and removal of redundant equipment



Whichever method you chose, you can be certain that the greatest number of potential buyers are informed and that you will receive a fair price for the equipment - our comprehensive database of clients will be notified by direct mail targeting as well as offering the assets through our website, etc.

Product Development

A.M.P Rose can arrange for specialist confectioners to be made available at your production site for new product development/existing product enhancements or staff training. Our range of expertise covers all types of chocolate, confectionery and gum products. Short and long-term contracts are available.

