



Semi-Automatic Depositors / Filling Machines

Riggs Autopack's Model 1000 range of semi-automatic depositors / filling machines provides accurate, damage free depositing of hot or cold wet foods and liquid products.



Riggs Autopack Ltd
Southfield Street, Nelson, Lancashire, UK
BB9 0LD
Tel: 01282 440040
Email: info@autopack.co.uk
Web: www.autopack.co.uk

Table Top Depositor / Filling Machine

Our entry level, Model 1000 table top filling machine provides damage free depositing of hot or cold "wet" food products, liquids, semi-liquids and suspended solids. Ideally suited to start-up companies and cottage industries, this compact, volumetric depositor contains a 40 litre hopper and accurately fills almost any type or size of container including jars, bottles, pots, tubs, trays, buckets, pouches and bags.

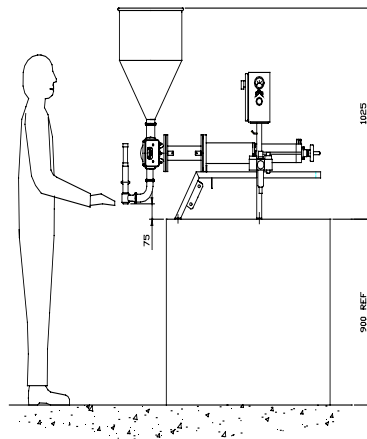
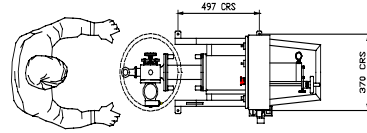

Option 1 Depositor / Filling Machine

Our Model 1000 Option 1 filling machine provides damage free depositing of hot or cold "wet" food products, liquids, semi-liquids and suspended solids. Ideally suited to start-up companies, cottage industries and medium sized food manufacturers, this mobile depositor contains a 40 litre hopper and height adjustable filling table. It accurately fills almost any type or size of container including jars, bottles, pots, tubs, trays, buckets, pouches and bags.

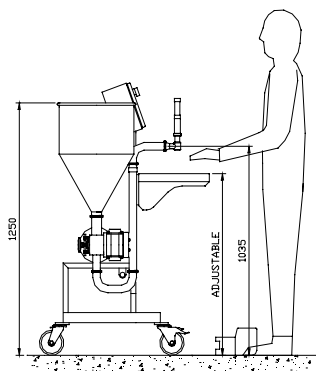
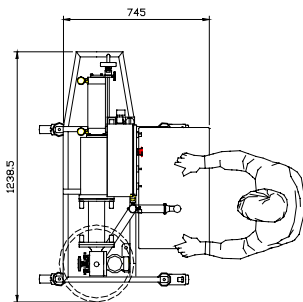

Option 2 Depositor / Filling Machine

Our Model 1000 Option 2 filling machine is ideally suited to medium or large sized food manufacturing companies and designed for presentation to a bench or conveyor filling line.

This mobile, volumetric depositor contains a 100 litre hopper with an interlocked guard lid and provides damage free depositing of hot or cold "wet" food products, liquids, semi-liquids and suspended solids. It accurately fills almost any type or size of container including jars, bottles, pots, tubs, trays, buckets, pouches and bags.

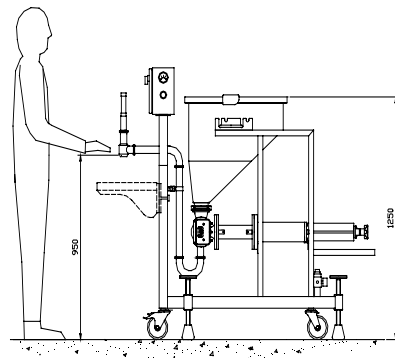
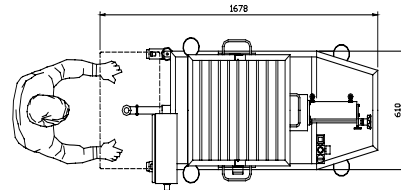

Option 3 Depositor / Filling Machine

Our Model 1000 Option 3 filling machine is designed for those food manufacturers that use conveyor filling lines as part of their food production process and can be presented to a conveyor either at a right angle or parallel.

This mobile, volumetric filling machine contains a 40 litre hopper with an interlocked guard lid and provides damage free depositing of hot or cold "wet" food products, liquids, semi-liquids and suspended solids. It accurately fills almost any type or size of container including jars, bottles, pots, tubs, trays, buckets, pouches and bags.

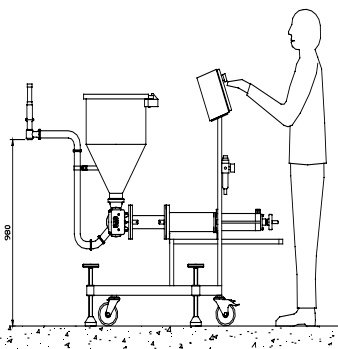
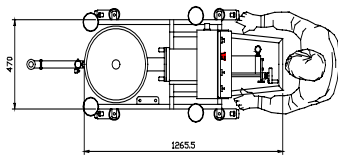

Bespoke Depositors / Filling Machines

We can work with you on a bespoke basis to design and build a semi or fully automatic, single or multi-head, low or high level filling machine that meets your exact food production demands. Tell us what you need and we'll build it.



Riggs Autopack's volumetric depositors / filling machines can be supplied with the following options to suit your food production needs -

- Semi or fully automatic
- Mobile or fixed frame
- Single or multi-head dispensing
- Low level or high level mounted
- Stand-alone or conveyorised filling
- Mini-fill, standard or maxi-fill pump options with a single deposit range of 3ml – 5000ml

Standard features of our filling machinery include -

- Designed and built in-house at our Lancashire factory
- High quality, robust construction using 316 food grade stainless steel
- Pneumatically operated, requires compressed air supply
- Suitable for depositing hot or cold liquids, semi-liquids and suspended solids
- Fully adjustable depositing volumes and operating speeds
- Operator friendly
- Hygienic, easy to clean, quick to strip down, simple to maintain
- Available for outright purchase, short or long term hire, no-obligation on site trial
- Comprehensive guarantee and full after sales support



Riggs Autopack Ltd, Southfield Street,
Nelson, Lancashire, UK, BB9 0LD
Tel. +44 (0) 1282 440040

