



infinity
aluminium pipework systems

Catalogue 2014

Free Delivery on All Orders Over £300 Nett

No Minimum Order Charge

www.infinitypipework.co.uk

sales@infinitypipework.co.uk



INFINITY LINE

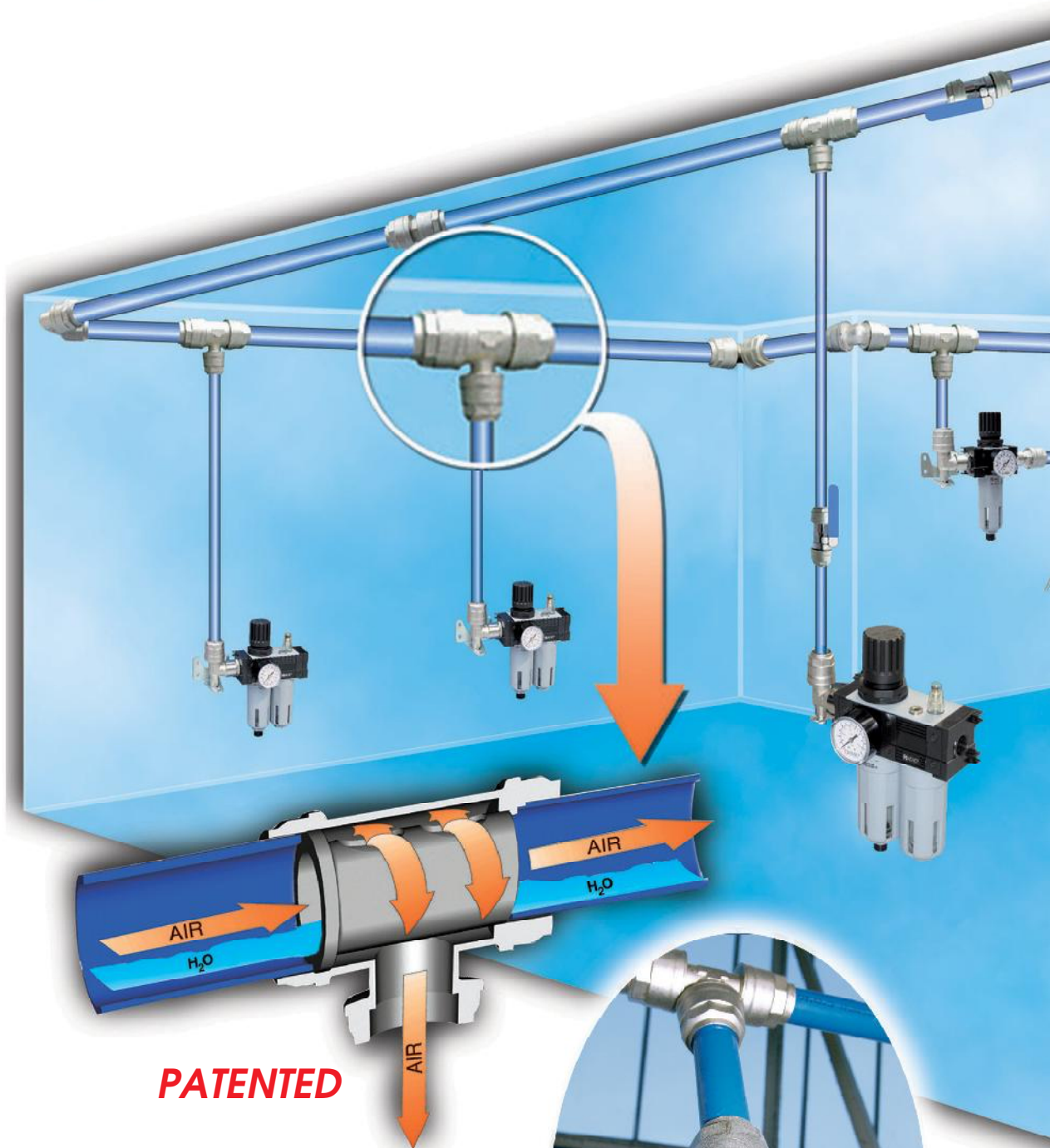

**RACCORDI AUTOMATICI PER GLI
IMPIANTI DI DISTRIBUZIONE DELL'ARIA**
*PUSH-IN FITTINGS FOR INSTALLATION OF
COMPRESSED-AIR PIPELINES*

FACILITA' E RAPIDITA' DI MONTAGGIO
EASINESS AND QUICKNESS OF ASSEMBLING

SISTEMA DI SEPARAZIONE DELLA CONDENSA
SEPARATION SYSTEM FOR THE CONDENSE

GAMMA COMPLETA DI ACCESSORI
WIDE RANGE OF ACCESSORIES



AFFIDABILITA' E SICUREZZA
RELIABILITY AND SECURITY

ELEVATA PORTATA D'ARIA
HIGH FLOW RATE

MOVE THE AIR POWER

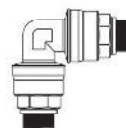

Caratteristiche tecniche / Technical characteristics

ø20 - ø25 - ø32 - ø40 - ø50 - ø63

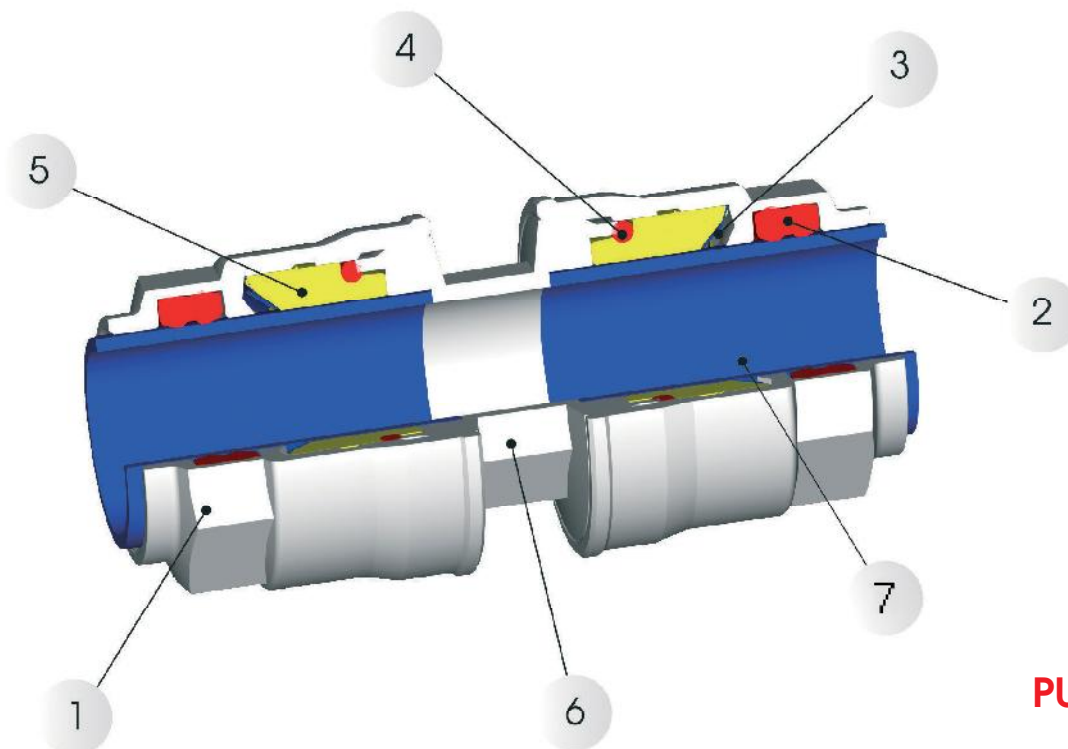

PUSH-IN

Materiali e componenti / Component part and materials

- 1 Dado in Ottone Nichelato (alluminio ø63)
- 2 Guarnizione in NBR
- 3 Pinza D'aggraffaggio in INOX AISI 304
- 4 Guarnizione O-RING in NBR
- 5 Anello di Sicurezza in Tecnopolimero
- 6 Corpo in Ottone Nichelato (alluminio ø63)
- 7 Tubo in alluminio estruso verniciato calibrato
Colore Blu (RAL 5010) - Colore Grigio (RAL 7035).

- 1 Nut made in Nickel-Plated Brass (aluminum ø63)
- 2 Seal made in NBR
- 3 Clamping Washer made in Inox AISI 304
- 4 O-RING Seals made in NBR
- 5 Safety Ring made in Technopolymeric
- 6 Body made in Nickel-Plated Brass (aluminum ø63)
- 7 Extruded Aluminium tube calibrated and powder coated
Blue Color (RAL 5010) - Gray Color (RAL 7035).

Pressioni / Pressures

Pressione minima / Minimum pressure -0.99 bar (0.099 Mpa)
Pressione massima / Maximum pressure 16 bar (1.6 Mpa)

Temperature / Temperatures

Temperatura minima / Minimum temperature -20°C
Temperatura massima / Maximum temperature +80°C

Fluidi compatibili / Compatible fluids

Aria compressa / Compressed air.
Vuoto / Vacuum
Gas inerti (AZOTO, ARGON) / Inert Gas (AZOTO, ARGON)

Tenuta al fuoco / Fire resistance

Il sistema non alimenta e non propaga il fuoco
The system does not stroke or propagate any fires

Filettature / Threads

Maschi gas conico ISO7
Male threads taper in conformity with ISO
Femmine gas cilindrica ISO228
Female threads in conformity with ISO 228

Caratteristiche tecniche dei tubi Technical characteristics to the tubes

Alluminio estruso Extruded Aluminium	UNI 9006/1 Al Mg 0.5 Si 0.4 Fe 0.2
Designazioni UNI EN 573-3 Designations UNI EN 573-3	EN AW 6060 T6
Treatmento superficiale Surface treatment	Verniciatura elettrostatica Electrostatic painting
Peso specifico Specific weight	2.70 Kg/dm ³
Coefficiente di dilatazione Expansion coefficient	0.024 mm/(m °C)

ø80 - ø110

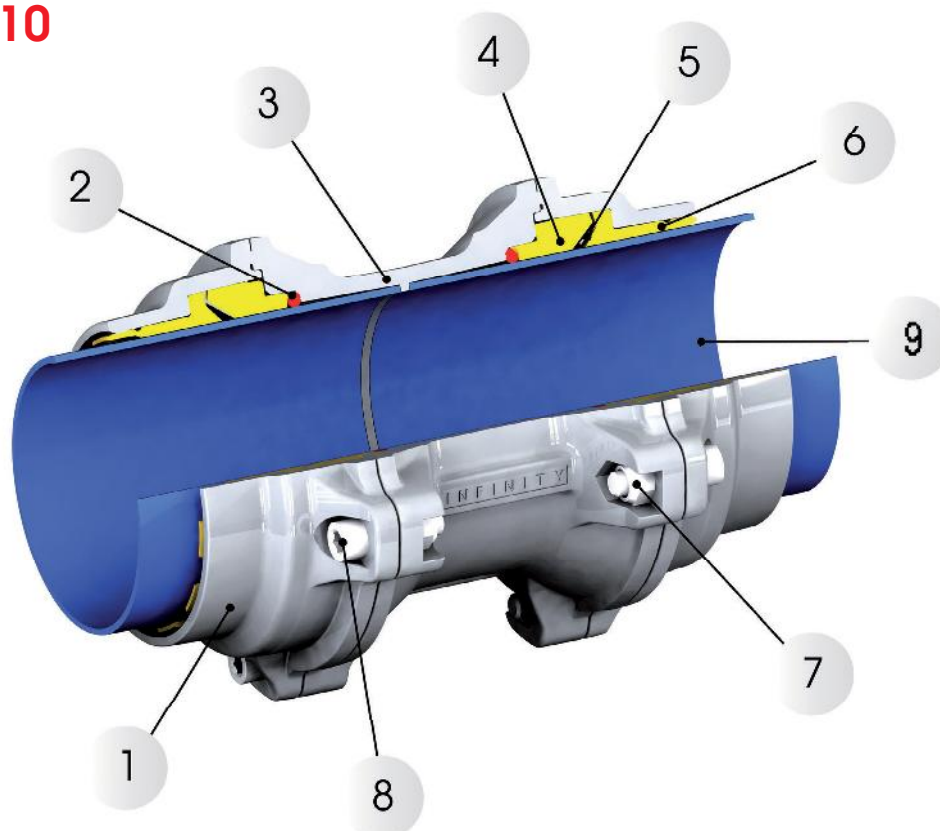

PUSH-IN

Materiali e componenti / Component part and materials

- | | |
|---|--|
| 1 Dado in alluminio trattato superficialmente | 1 Nut made in aluminium with finished surface treatment |
| 2 Guarnizione O-RING in NBR | 2 O-RING Seal made in NBR |
| 3 Corpo in alluminio trattato superficialmente | 3 Body made in aluminium with finished surface treatment |
| 4 Anello di sicurezza in Tecnopolimero | 4 Safety Ring made in Technopolymeric |
| 5 Pinza d'aggraffaggio in INOX AISI 301 | 5 Clamping Washer made in AISI 301 |
| 6 Anello guida-tubo in Tecnopolimero | 6 Tube-guide Ring made in technopolymeric |
| 7 Dado autobloccante in acciaio zincato | 7 Selflocking Nut in Zinc-Plated Steel |
| 8 Vite TCEI in acciaio zincato | 8 TCEI Screw in Zinc-Plated Steel |
| 9 Tubo in alluminio estruso verniciato calibrato
Colore Blu (RAL 5010) - Colore Grigio (RAL 7035). | 9 Extruded Aluminium tube calibrated and powder coated
Blue Color (RAL 5010) - Grey Color (RAL 7035). |

Pressioni / Pressures

Pressione minima / Minimum pressure **-0.99 bar (0.099 Mpa)**
 Pressione massima / Maximum pressure **16 bar (1.6 Mpa)**

Fluidi compatibili / Compatible fluids

Aria compressa / Compressed air.
 Vuoto / Vacuum
 Gas inerti (AZOTO, ARGON) / Inert Gas (AZOTO, ARGON)

Filettature / Threads

Raccordo flangiato UNI EN 1092 - 4 PN 16
 Raccordo flangiato DIN UNI EN 1092 - 4 PN 16
 Femmine gas cilindrica ISO228
 Female threads in conformity with ISO 228

Temperature / Temperatures

Temperatura minima / Minimum temperature **-20°C**
 Temperatura massima / Maximum temperature **+80°C**

Tenuta al fuoco / Fire resistance

Il sistema non alimenta e non propaga il fuoco
 The system does not stroke or propagate any fires

Caratteristiche tecniche dei tubi Technical characteristics to the tubes

Alluminio estruso Extruded Aluminium	UNI 9006/1 Al Mg 0.5 Si 0.4 Fe 0.2
Designazioni UNI EN 573-3 Designations UNI EN 573-3	EN AW 6060 T6
Trattamento superficiale Surface treatment	Verniciatura elettrostatica Electrostatic painting
Peso specifico Specific weight	2.70 Kg/dm ³
Coefficiente di dilatazione Expansion coefficient	0.024 mm/(m °C)

Montaggio Impianto - Installation $\varnothing 20$ - $\varnothing 25$ - $\varnothing 32$ - $\varnothing 40$



1

1 I raccordi $\varnothing 20$ - $\varnothing 25$ - $\varnothing 32$ - $\varnothing 40$ sono premontati con dado già serrato. I tubi di 4 e 6 mt sono già verniciati, calibrati e sbavati.
Fittings of $\varnothing 20$ - $\varnothing 25$ - $\varnothing 32$ - $\varnothing 40$ are pre-assembled. Tubes of 4 & 6 mt are pre-coated, calibrated and burred.

2 Inserire il tubo nel raccordo sino in battuta per la connessione automatica.

Push tube into the fitting for automatic connection.

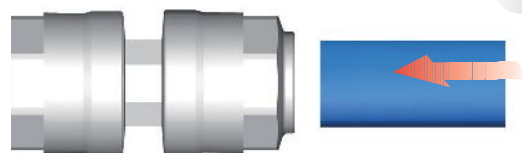

2

3 Nel caso si dovesse smontare un raccordo, utilizzare le coppie di serraggio riportate in tabella per il successivo montaggio.

In case of fitting disassembling, use the torques as in the chart to re-assemble the fitting.

3

Diametro Diameter	Coppia Torque
20	300 cN.m
25	300 cN.m
32	400 cN.m
40	650 cN.m

Montaggio Impianto - Installation $\varnothing 50$ - $\varnothing 63$



1

1 I raccordi $\varnothing 50$ - $\varnothing 63$ sono premontati con dado allentato per facilitare l'inserimento del tubo. I tubi di 4 e 6 mt sono già verniciati, calibrati e sbavati.

Fittings of $\varnothing 50$ - $\varnothing 63$ are pre-assembled with nut untwisted to help tube connection. Tubes of 4 & 6 mt are pre-coated, calibrated and burred.

2 Inserire il tubo nel raccordo sino in battuta per la connessione e serrare il dado utilizzando la coppia di serraggio riportata in tabella.

Push tube into the fitting for connection and tighten the nut using torques as in the chart.

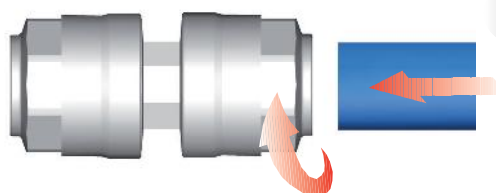

2

Diametro Diameter	Coppia Torque
50	75 N.m
63	75 N.m
63 (alluminio - aluminum)	85 N.m

Montaggio Impianto - Installation $\varnothing 80 - \varnothing 110$

1

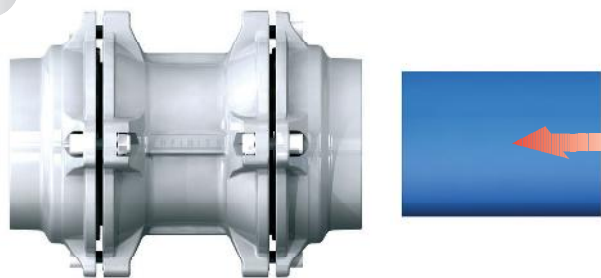

1 I raccordi $\varnothing 80$ e $\varnothing 110$ sono premontati con quattro viti allentate per facilitare l'inserimento del tubo. I tubi di 4 e 6 mt sono già verniciati, calibrati e sbavati.

Fittings of $\varnothing 80$ e $\varnothing 110$ are pre-assembled with four screws untwisted to help tube connection. Tubes of 4 & 6 mt are pre-coated, calibrated and burred.

2 Inserire il tubo nel raccordo sino in battuta per la connessione automatica e stringere le quattro viti nella sequenza suggerita. Coppia di serraggio 30Nm.

Push tube into the fitting for automatic connection and screw up in the suggested sequence. Tightening torque 30Nm.

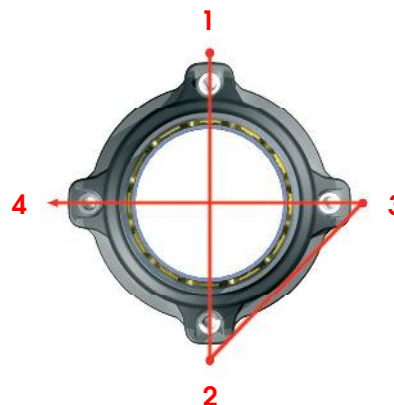
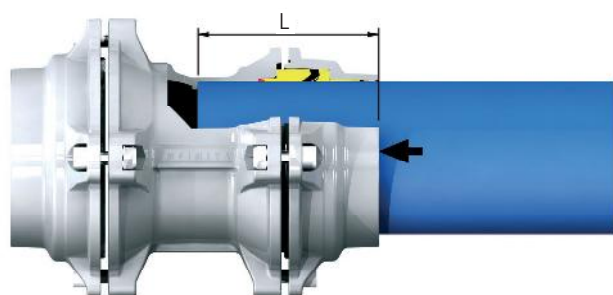

Inserimento tubo - Tube Connection

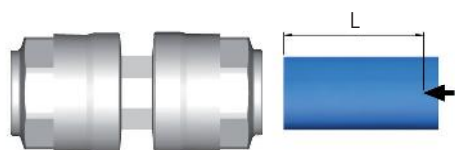

La corretta connessione del tubo è confermata dalla posizione della freccia pre marcata. In caso esistesse la necessità di tagliare il tubo, si consiglia di segnare la lunghezza del tubo che va inserita nel raccordo.

The correct connection of tube is confirmed by the position of the arrow pre-stamp. If you need to cut the tube, mark the distance of tube to insert in the fitting.

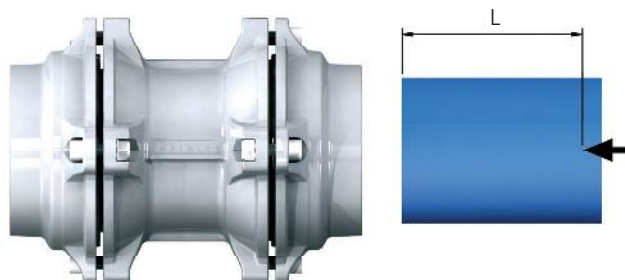

Diametro Diameter	L mm
20	31,5 mm
25	38,5 mm
32	46 mm
40	52 mm
50	63,5 mm
63	75,5 mm
63 (alluminio - aluminum)	57,5 mm
80	91 mm
110	125,5 mm

Dimensionamento della rete / Chose the diameter four the installation

La tabella sottostante permette di determinare il diametro della linea principale.

The Diagram below allows to determinate the diameter of the main line.

- Trovare la portata del compressore nella colonna rossa.**
Choose the Flow rate of compressor in the Red column.
- Trovare la distanza fra compressore e utilizzo piu' lontano nella riga blu.**
Choose the Distance between compressor and the most distant using point in the Blue column.
- Trovare il diametro incrociando la riga della portata con la colonna della distanza.**
Cross the lines of Flow rate and blue column of Distance to choose the diameter.

Portata Flow Rate NI/min Nm ³ /h cfm			Distanza fra compressore e utilizzo più lontano Distance between compressor and the most distant using point.										
			25m 82ft	50m 164ft	100m 328ft	150m 492ft	200m 656ft	300m 984ft	400m 1312ft	500m 1640ft	1000m 3280ft	1500m 4921ft	2000m 6562ft
230	14	8	20	20	20	20	20	20	20	20	25	25	
650	39	23	20	20	20	20	25	25	25	25	32	32	40
900	54	32	20	20	25	25	25	32	32	32	40	40	40
1200	72	42	20	20	25	25	32	32	32	32	40	40	50
1750	105	62	20	25	32	32	32	40	40	40	50	50	50
2000	120	71	25	25	32	32	32	40	40	40	50	50	50
2500	150	88	25	32	32	32	40	40	40	50	50	63	63
3000	180	106	25	32	32	40	40	40	50	50	50	63	63
3500	210	124	25	32	40	40	40	50	50	50	63	63	63
4500	270	159	32	32	40	40	50	50	50	50	63	63	80
6000	360	212	32	40	50	50	50	50	63	63	80	80	80
7000	420	247	32	40	50	50	50	63	63	63	80	80	80
8500	510	300	40	40	50	50	63	63	63	63	80	80	110
12000	720	424	40	50	63	63	63	80	80	80	110	110	110
15000	900	530	50	50	63	63	80	80	80	80	110	110	110
18000	1080	636	50	63	63	80	80	80	80	110	110	110	110
21000	1260	742	50	63	63	80	80	80	110	110	110	110	110
26000	1560	918	63	63	80	80	80	110	110	110	110	110	110
31000	1860	1095	63	63	80	80	110	110	110	110	110	110	110*
33000	1980	1165	63	80	80	110	110	110	110	110	110	110*	110*
44000	2640	1554	63	80	110	110	110	110	110	110	110*	110*	110*
50000	3000	1766	80	80	110	110	110	110	110	110	110*	110*	110*
58000	3480	2048	80	80	110	110	110	110	110	110	110*	110*	110*
67000	4020	2366	80	110	110	110	110	110	110	110*	110*	110*	110*
75000	4500	2648	80	110	110	110	110	110	110*	110*	110*	110*	110*
83000	4980	2931	80	110	110	110	110	110*	110*	110*	110*	110*	110*
92000	5520	3249	110	110	110	110	110	110*	110*	110*	110*	110*	110*
100000	6000	3531	110	110	110	110	110*	110*	110*	110*	110*	110*	110*

Pressione 7 bar - Perdita di carico totale 4% / Pressure 7 bar - Total pressure drop 4%

* La perdita di carico è superiore al 4% / * Pressure drop is higher than 4%

Esempio / Example

Portata: **3000 NL/min**

Distanza fra compressore e
utilizzo più lontano: **300 m**

Diametro tubo: **40**

Flow rate: **3000 NL/min**

Distance between compressor
and most distant using point: **300 m**

Tube diameter: **40**

Portate indicative dei compressori a 7 bar / Indicative flow rates of the compressors to 7

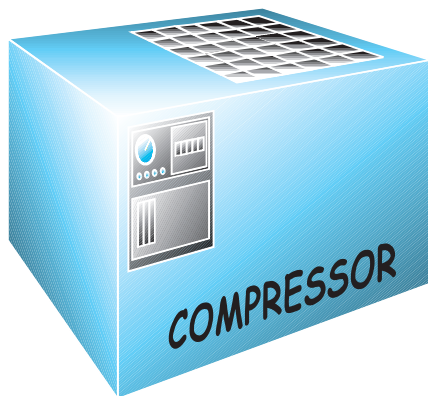

KW	CV	NI/min
1.5	2	230
3	4	460
4	6	650
5.5	7,5	900
7.5	10	1200
11	15	1750
12.5	17	2000
15	20	2500
18	25	3000
22	30	3500
29	40	4500
37	50	6000
45	60	7000
55	75	8500
74	100	12000
92	125	15000
110	150	18000
132	180	21000
170	230	26000
200	270	31000
250	340	44000

Distanza fra compressore e utilizzo più lontano

Distance between compressor and the most distant using point.

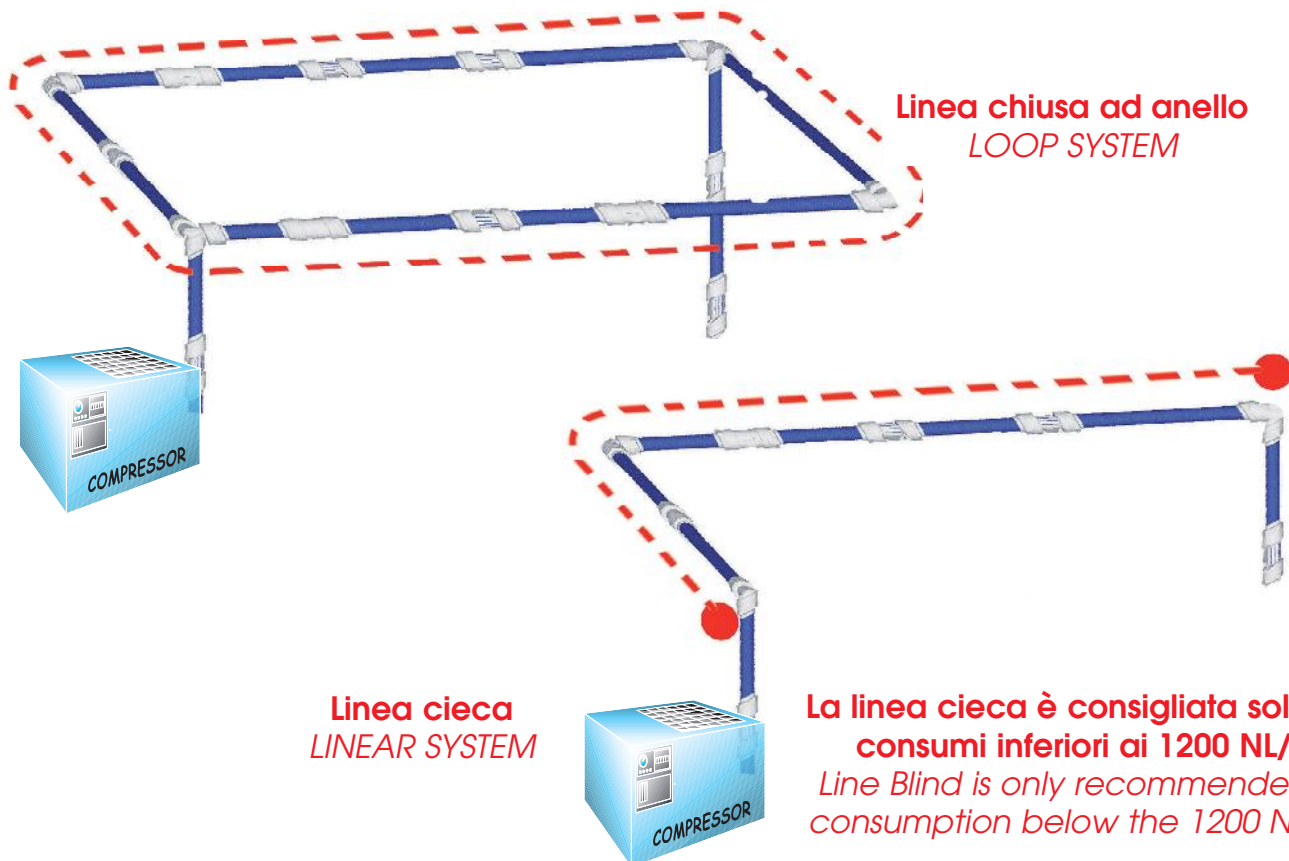

Distanza fra compressore e utilizzo più lontano

Distance between compressor and the most distant using point.

Tubo di calata / Tube diameter for the outlets

Sono previste calate:

Ø20 con portata fino a 2000 NI/min
 Ø25 con portata fino a 3500 NI/min
 Ø32 con portata fino a 7000 NI/min

Specifications about available tube diameters for the outlets:

Ø 20 with flow rate till 2000 NI/min
 Ø 25 with flow rate till 3500 NI/min
 Ø 32 with flow rate till 7000 NI/min

Dilatazioni e contrazioni termiche / Expansion and shrinkage due to the heat

Per calcolare la dilatazione - contrazione lineare utilizziamo la seguente formula:

$$\Delta L = \Delta T \times L \times \alpha \text{ dove:}$$

- ΔL = dilatazione - contrazione lineare in mm
- ΔT = variazione di temperatura tra quella di esercizio e quella di posa in °C
- L = lunghezza tubo in m
- α = coefficiente di dilatazione termica lineare che per l'alluminio é 0.024 mm/ m °C

- L'impianto deve essere posto in modo che all'estremità si preveda uno spazio che ne consenta la dilatazione-contrazione, ed i supporti devono essere posizionati come in figura:

To calculate the linear expansion - shrinkage we can use the following formula:

$$\Delta L = \Delta T \times L \times \alpha \quad \text{i.e.:$$

- ΔL = Linear expansion - shrinkage in mm
- ΔT = Heat variation between the operating temperature and the installation one at °C
- L = Tube length in m
- α = Linear expansion factor, for the aluminium it is 0.024 mm/ m °C

- The installation have to be positioned, considering at the two ends free space which permits the expansion - shrinkage and supports have to be fixed as showed in the picture:

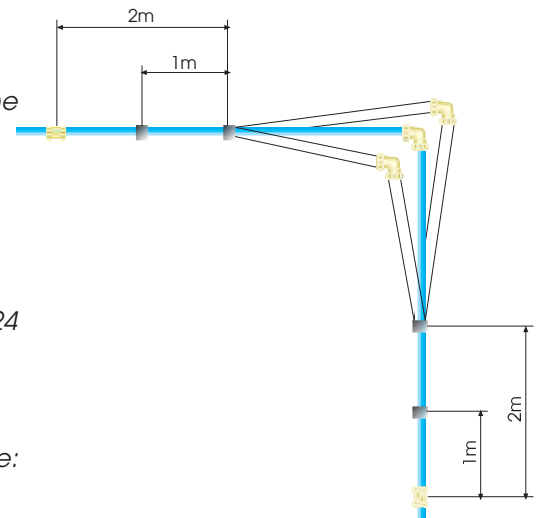



90000 - 4MT NEW

TUBI IN ALLUMINIO CALIBRATI DI COLORE BLU
CALIBRATED ALUMINIUM TUBES BLUE COLOUR

Codice Code	Ø Esterno	Spessore	Pressione	Peso	Lung.	Conf.
	Outside Ø	Thickness	Pressure	Weight	Length	Pack.
	mm	mm	bar	gr/m	4 Mt.	
900000011Y9B5	20	1.5	16	235	4 m	8
900000011J4B5	25	1.5	16	298	4 m	8
900000011J9B5	32	1.5	16	387	4 m	9
900000011K4B5	40	1.5	16	490	4 m	9
900000011W0B5	50	2	16	814	4 m	4
900000011W3B5	63	2	16	1034	4 m	4
900000011TPB5	80	2	16	1493	4 m	2
900000011HTB5	110	2.5	16	2280	4 m	2

90000GR - 4MT NEW

TUBI IN ALLUMINIO CALIBRATI DI COLORE GRIGIO
CALIBRATED ALUMINIUM TUBES GREY COLOUR

Codice Code	Ø Esterno	Spessore	Pressione	Peso	Lung.	Conf.
	Outside Ø	Thickness	Pressure	Weight	Length	Pack.
	mm	mm	bar	gr/m	4 Mt.	
900000011Y9GR	20	1.5	16	235	4 m	8
900000011J4GR	25	1.5	16	298	4 m	8
900000011J9GR	32	1.5	16	387	4 m	9
900000011K4GR	40	1.5	16	490	4 m	9
900000011W0GR	50	2	16	814	4 m	4
900000011W3GR	63	2	16	1034	4 m	4
900000011TPGR	80	2	16	1493	4 m	2
900000011HTGR	110	2.5	16	2280	4 m	2

90000 - 6MT NEW

TUBI IN ALLUMINIO CALIBRATI DI COLORE BLU
CALIBRATED ALUMINIUM TUBES BLUE COLOUR

Codice Code	Ø Esterno	Spessore	Pressione	Peso	Lung.	Conf.
	Outside Ø	Thickness	Pressure	Weight	Length	Pack.
	mm	mm	bar	gr/m	6 Mt.	
900006020BL	20	1.5	16	235	6 m	8
900006025BL	25	1.5	16	298	6 m	8
900006032BL	32	1.5	16	387	6 m	9
900006040BL	40	1.5	16	490	6 m	4
900006050BL	50	2	16	814	6 m	4
900006063BL	63	2	16	1034	6 m	2
900006080BL	80	2	16	1493	6 m	2
900006110BL	110	2.5	16	2280	6 m	1

90000GR - 6MT NEW

TUBI IN ALLUMINIO CALIBRATI DI COLORE GRIGIO
CALIBRATED ALUMINIUM TUBES GREY COLOUR

Codice Code	Ø Esterno	Spessore	Pressione	Peso	Lung.	Conf.
	Outside Ø	Thickness	Pressure	Weight	Length	Pack.
	mm	mm	bar	gr/m	6 Mt.	
900006020GR	20	1.5	16	235	6 m	8
900006025GR	25	1.5	16	298	6 m	8
900006032GR	32	1.5	16	387	6 m	9
900006040GR	40	1.5	16	490	6 m	4
900006050GR	50	2	16	814	6 m	4
900006063GR	63	2	16	1034	6 m	2
900006080GR	80	2	16	1493	6 m	2
900006110GR	110	2.5	16	2280	6 m	1

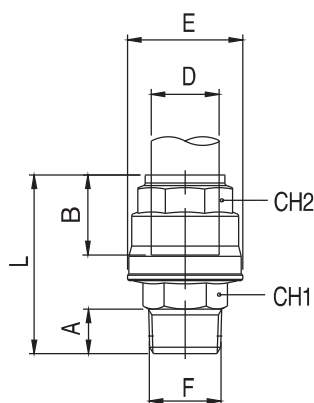

90010

NEW

RACCORDO DIRITTO MASCHIO - STRAIGHT MALE ADAPTOR

Codice Code	D	F	A	B	E	L	CH1	CH2	Conf. Pack.
9001000001	20	1/2	14	31.5	34.5	56	22	30	10
9001000002	25	3/4	16.5	38.5	42.5	66	27	35	5
9001000003	32	1"	19	46	52	76.5	34	45	2
9001000004	40	1 1/4	21.5	52	63	89.5	45	55	2
9001000007	40	1 1/2	21.5	52	63	92	50	55	2
9001000005	50	1 1/2	21.5	63.5	73	105	50	65	2
*9001000006	63	2"	24	59	92	107.5	65	70	2
9001000006A	63	2"	24	57.5	94	109.5	65	75	2
9001000008A	63	2 1/2	24	57.5	94	106.5	75	75	2

*FINO AD ESAURIMENTO SCORTA

*UNTIL THE END STOCK

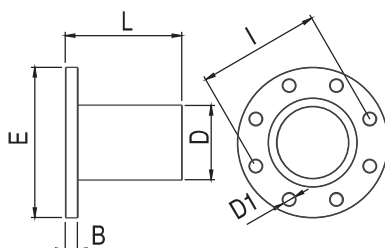

90015-80-110

NEW

TUBO FLANGIATO - FLANGED TUBE

Codice Code	D	B	E	L	D1	I	Conf. Pack.
9001500002	80	20	200	155	18	160	1
9001500001	110	20	220	183	18	180	1

Le dimensioni di accoppiamento della flangia rispettano la norma UNI EN 1092 - 4 PN 16 (Flange in leghe di alluminio).

The connection dimensions of the flange are designed in conformity with standard UNI EN 1092 - 4 PN 16 (Flange made in aluminium alloy).

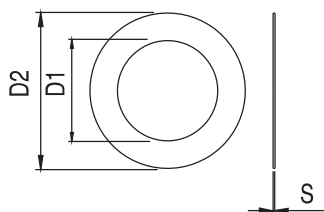

90017-80-110

NEW

GUARNIZIONE PIATTA PER FLANGIA
FLAT GASKET FOR FLANGE

Codice Code	D	D1	D2	S	Conf. Pack.
900170057TP00	80	89	131	2	1
900170057HT00	110	105	162	2	1



90019-80-110

NEW

KIT VITI PER FLANGIA - FLANGE KIT

Codice Code	LUNGHEZZA / SIZE	Conf. Pack.
9001900001	M16 65 mm	1

KIT: 8 VITI + 8 DADI + 16 RONDELLE
KIT: 8 SCREW + 8 NUT + 16 WASHER

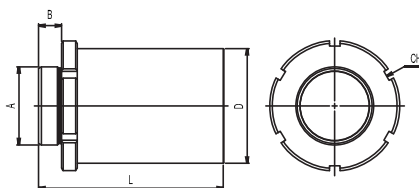

90020-80-110

NEW

TUBO - TUBE

Codice Code	D	A	B	L	CH	Conf. Pack.
9002000003	80	2"-1/2	22	143	*100	1
9002000004	80	3"	23	144	*100	1
9002000001	110	2"-1/2	22	178	*125	1
9002000002	110	3"	23	179	*125	1

*DIMENSIONI CHIAVE A SETTORE

*HOOK WRENCH DIMENSIONS

Montaggio / Installation 90015

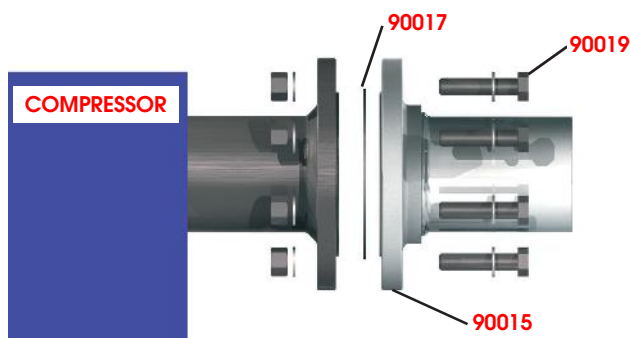

Per collegare l'impianto al compressore utilizzare il tubo flangiato art. 90015.

To connect the pipe system to the compressor use flanged tube art.90015

Porre la guarnizione art. 90017 tra la flangia del compressore e art. 90015. Stringere le otto viti art. 90019. Coppia di serraggio 60 Nm.

Lay flange gasket art. 90017 between compressor flange and art. 90015. Tighten the eight screws art. 90019. Tightening torque 60 Nm.



A montaggio ultimato si presenta così.

See right-hand side picture for final assembly.

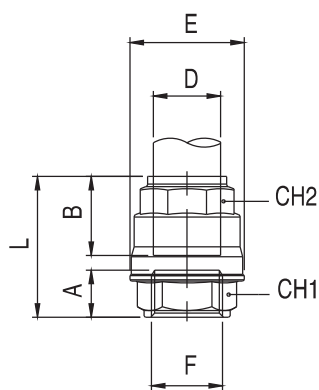

90030

RACCORDO DIRITTO FEMMINA - STRAIGHT FEMALE ADAPTOR

Codice Code	D	F	A	B	E	L	CH1	CH2	Conf. Pack.
9003000001	20	1/2	15	31.5	34.5	49	24	30	10
9003000002	25	3/4	16.5	38.5	42.5	56.5	32	35	5
9003000003	32	1"	19	46	52	66.5	38	45	2
9003000004	40	1"1/4	22	52	63	76	50	55	2
9003000005	50	1"1/2	22	63.5	73	85.5	55	65	2
*9003000006	63	2"	22	59	92	82.5	65	70	2

*FINO AD ESAURIMENTO SCORTA

*UNTIL THE END STOCK

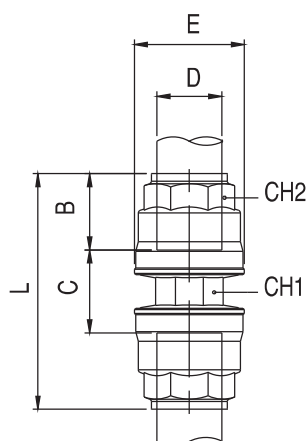

90040

RACCORDO DIRITTO INTERMEDIO - STRAIGHT CONNECTOR

Codice Code	D	B	C	E	L	CH1	CH2	Conf. Pack.
9004000001	20	31.5	14.5	34.5	76.5	21	30	5
9004000002	25	38.5	13.5	42.5	90.5	26	35	5
9004000003	32	46	14.5	52	106.5	32	45	2
9004000004	40	52	21	63	125	41	55	2
9004000005	50	63.5	21.5	73	148.5	50	65	2
*9004000006	63	59	25	92	160	65	70	1
9004000006A	63	57.5	44	94	159	73	75	1

*FINO AD ESAURIMENTO SCORTA

*UNTIL THE END STOCK

NEW

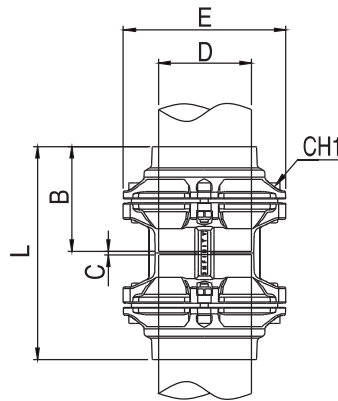

90040-80-110

NEW

RACCORDO DIRITTO INTERMEDIO - STRAIGHT CONNECTOR

Codice Code	D	B	C	E	L	CH1	Conf. Pack.
9004000007	80	91	3.5	145	186	6	1
9004000008	110	125.5	4	200	255	8	1

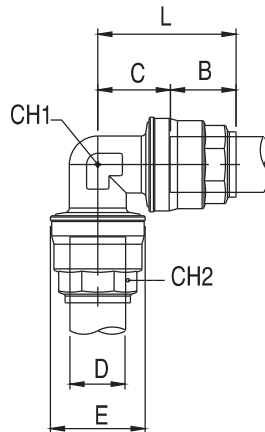

90130

NEW

RACCORDO A L INTERMEDIO - ELBOW CONNECTOR

Codice Code	D	B	C	E	L	CH1	CH2	Conf. Pack.
9013000001	20	31.5	19	34.5	51	21	30	4
9013000002	25	38.5	23	42.5	61.5	26	35	4
9013000003	32	46	28	52	74.5	34	45	2
9013000004	40	52	34	63	86.5	41	55	2
9013000005	50	63.5	40.5	73	104	50	65	2
*9013000006	63	59	52	92	111	65	70	1
9013000006A	63	57.5	55.5	94	113	73	75	1

*FINO AD ESAURIMENTO SCORTA
*UNTIL THE END STOCK

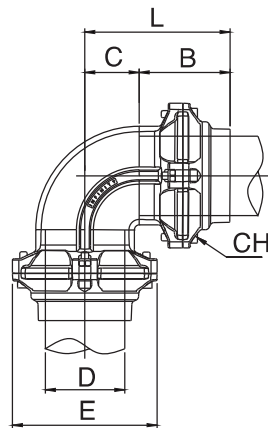

90130-80-110

NEW

RACCORDO A L INTERMEDIO - ELBOW CONNECTOR

Codice Code	D	B	C	E	L	CH	Conf. Pack.
9013000007	80	91	54.5	145	146	6	1
9013000008	110	125.5	75	200	200.5	8	1

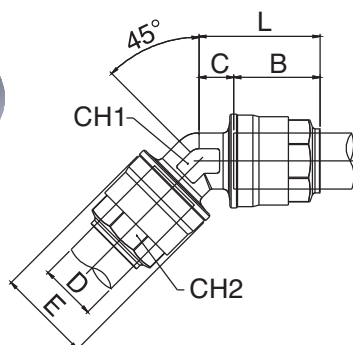

90140

NEW

RACCORDO A 135° INTERMEDIO - 135° CONNECTOR

Codice Code	D	B	C	E	L	CH1	CH2	Conf. Pack.
9014000001	20	31.5	12.5	34.5	44	21	30	4
9014000002	25	38.5	13.5	42.5	52	26	35	4
9014000003	32	46	15	52	61	34	45	2
9014000004	40	52	18	63	70	41	55	2
9014000005	50	63.5	20	73	83.5	50	65	2
*9014000006	63	59	24	92	83	65	70	1
9014000006A	63	57.5	24	94	82	73	75	1

*FINO AD ESAURIMENTO SCORTA
*UNTIL THE END STOCK

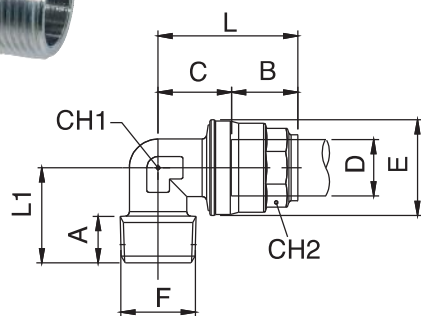

90150

RACCORDO A L MASCHIO-TUBO
ELBOW CONNECTOR MALE-TUBE

Codice Code	D	F	A	B	C	E	L	L1	CH1	CH2	Conf. Pack.
9015000001	20	1/2	14	31.5	19	34.5	51	32	21	30	4
9015000002	25	3/4	16.5	38.5	23	42.5	61.5	37	26	35	4
9015000003	32	1"	19	46	28	52	74.5	49	34	45	2
9015000004	40	1"-1/4	21.5	52	34	63	86.5	54	41	55	2
9015000005	50	1"-1/2	21.5	63.5	40.5	73	104	59	50	65	2
*9015000006	63	2"	24	59	52	92	111	71	65	70	1

*FINO AD ESAURIMENTO SCORTA
*UNTIL THE END STOCK

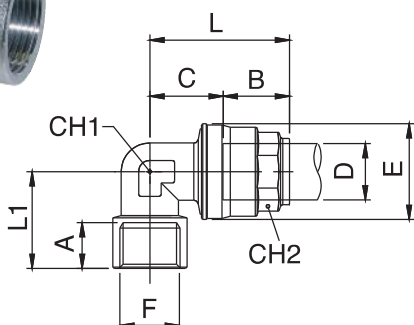

90160

RACCORDO A L FEMMINA-TUBO
ELBOW CONNECTOR FEMALE-TUBE

Codice Code	D	F	A	B	C	E	L	L1	CH1	CH2	Conf. Pack.
9016000001	20	1/2	13	31.5	19	34.5	51	34.5	21	30	4
9016000002	25	3/4	14.5	38.5	23	42.5	61.5	38.5	26	35	4
9016000003	32	1"	16.5	46	28	52	74.5	47.5	34	45	2
9016000004	40	1"-1/4	20	52	34	63	86.5	56.5	41	55	2
9016000005	50	1"-1/2	22	63.5	40.5	73	104	64.7	50	65	2
*9016000006	63	2"	21.7	59	52	92	111	77	65	70	1

*FINO AD ESAURIMENTO SCORTA
*UNTIL THE END STOCK

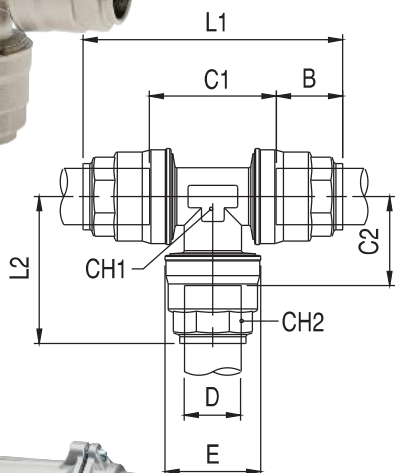

90230

RACCORDO A T INTERMEDIO - TEE CONNECTOR

Codice Code	D	E	B	C1	C2	L1	L2	CH1	CH2	Conf. Pack.
9023000001	20	34.5	31.5	34.5	22.5	98	54.5	21	30	3
9023000002	25	42.5	38.5	37.5	26	113.5	65	26	35	3
9023000003	32	52	46	46.5	31.5	138.5	77	34	45	2
9023000004	40	63	52	55.5	38	159.5	90	41	55	1
9023000005	50	73	63.5	69	44.5	196	108	50	65	1
*9023000006	63	92	59	87	55.5	205.5	114.5	65	70	1
9023000006A	63	94	57.5	111	55.5	226	113	73	75	1

*FINO AD ESAURIMENTO SCORTA
*UNTIL THE END STOCK

NEW

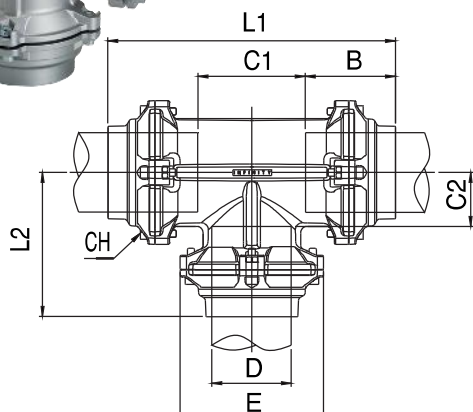

90230-80-110

RACCORDO A T INTERMEDIO - TEE CONNECTOR

Codice Code	D	E	B	C1	C2	L1	L2	CH	Conf. Pack.
9023000007	80	145	91	109	54.5	291.5	138	6	1
9023000008	110	200	125.5	150.5	75	401	200.5	8	1

NEW

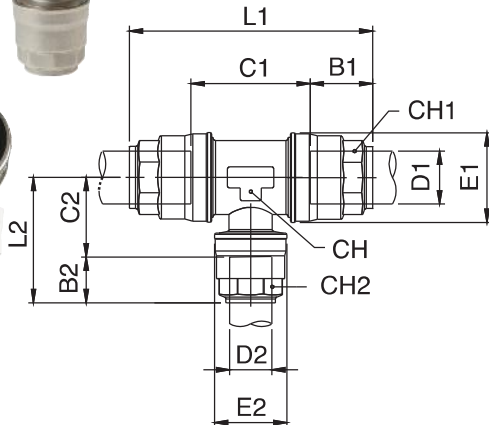

90235

RACCORDO PER CALATA - FITTING FOR OUTLET

Codice Code	D1	D2	B1	B2	C1	C2	E1	E2	L1	L2	CH	CH1	CH2	Conf. Pack.
9023500013	20	20	31.5	31.5	48	22.5	34.5	34.5	109	54	28	30	30	3
9023500001	25	20	38	31.5	45.5	27.5	42.5	34.5	121.5	59	35	35	30	3
9023500002	32	20	46	31.5	54.5	31.5	52	34.5	146.5	63	45	45	30	2
9023500003	32	25	46	38	54.5	31.5	52	42.5	146.5	70	45	45	35	2
9023500004	40	20	52.5	31.5	60	34.5	63	34.5	165.5	66	55	55	30	2
9023500005	40	25	52.5	38	60	34.5	63	42.5	165.5	73	55	55	35	2
9023500007	50	20	63.5	31.5	73.5	41.5	73	34.5	201	73	65	65	30	1
9023500008	50	25	63.5	38.5	73.5	41	73	42.5	201	80	65	65	35	1
9023500009	50	32	63.5	46	73.5	41	73	52	201	87.5	65	65	45	1
*9023500010	63	20	59	31.5	86	49.5	92	34.5	204.5	81	80	70	30	1
*9023500011	63	25	59	38.5	86	49	92	42.5	204.5	88	80	70	35	1
*9023500012	63	32	59	46	86	49	92	52	204.5	95.5	80	70	45	1

*FINO AD ESAURIMENTO SCORTA

*UNTIL THE END STOCK

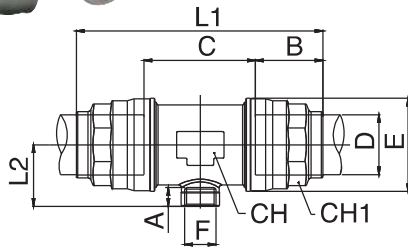

90236

RACCORDO PER CALATA FEMMINA - FEMALE FITTING FOR OUTLET

Codice Code	D	F	A	B	C	E	L1	L2	CH	CH1	Conf. Pack.
9023600006	20	3/8	11	31.5	48	34.5	109	25	28	30	3
9023600007	20	1/2	13.5	31.5	48	34.5	109	28	28	30	3
9023600001	25	3/8	11	38.5	45.5	42.5	121.5	29	35	35	3
9023600008	25	1/2	13.5	38.5	45.5	42.5	121.5	31	35	35	2
9023600002	32	1/2	13.5	46	54.5	52	146.5	36.5	45	45	2
9023600003	40	1/2	13.5	52.5	60	63	165.5	41.5	55	55	2
9023600004	50	3/4	14.5	63.5	73.5	73	201	47.5	65	65	1
*9023600005	63	3/4	14.5	59	86	92	204.5	55	80	70	1
9023600017A	63	1/2	13.5	57.5	88	94	203	53	80	75	1
9023600005A	63	3/4	14.5	57.5	88	94	203	54	80	75	1
9023600018A	63	1"	17.5	57.5	88	94	203	56.5	80	75	1

*FINO AD ESAURIMENTO SCORTA

*UNTIL THE END STOCK

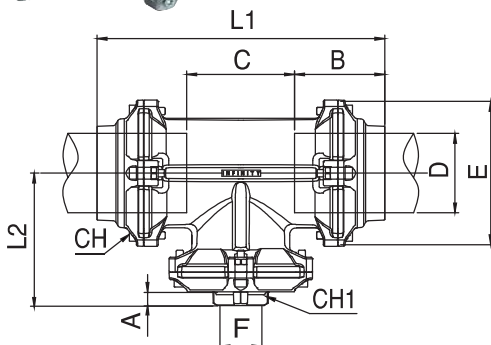

90236-80-110

RACCORDO PER CALATA FEMMINA - FEMALE FITTING FOR OUTLET

Codice Code	D	F	A	B	C	E	L1	L2	CH	CH1	Conf. Pack.
9023600009	80	3/4	14.5	91	109	145	291.5	138	6	*42	1
9023600010	80	1"	17	91	109	145	291.5	138	6	*49	1
9023600011	80	1"-1/2	20	91	109	145	291.5	138	6	*66	1
9023600012	80	2"	22	91	109	145	291.5	138	6	*80	1
9023600013	110	3/4	14.5	125.5	150.5	200	401	180	8	*42	1
9023600014	110	1"	17	125.5	150.5	200	401	180	8	*49	1
9023600015	110	1"-1/2	20	125.5	150.5	200	401	180	8	*66	1
9023600016	110	2"	22	125.5	150.5	200	401	180	8	*80	1

*DIMENSIONI CHIAVE A SETTORE

*HOOK WRENCH DIMENSIONS

Funzionamento / Function 90235 - 90236

Questo raccordo è una valida alternativa al tradizionale collo di cigno ma si dimostra una soluzione più rapida ed economica. L'efficace sistema interno permette all'aria, senza ridurre il passaggio, di giungere all'utilizzo priva di condensa che rimanendo nel circuito primario potrà essere così drenata nel punto più conveniente.

This fitting is a valid alternative to the traditional swan-neck; it shows itself as a quicker and cost effective solution. The efficient internal system allows to the air to reach the usage points without any condense which stays within the main circuit and than it can be drained in the most convenient point.

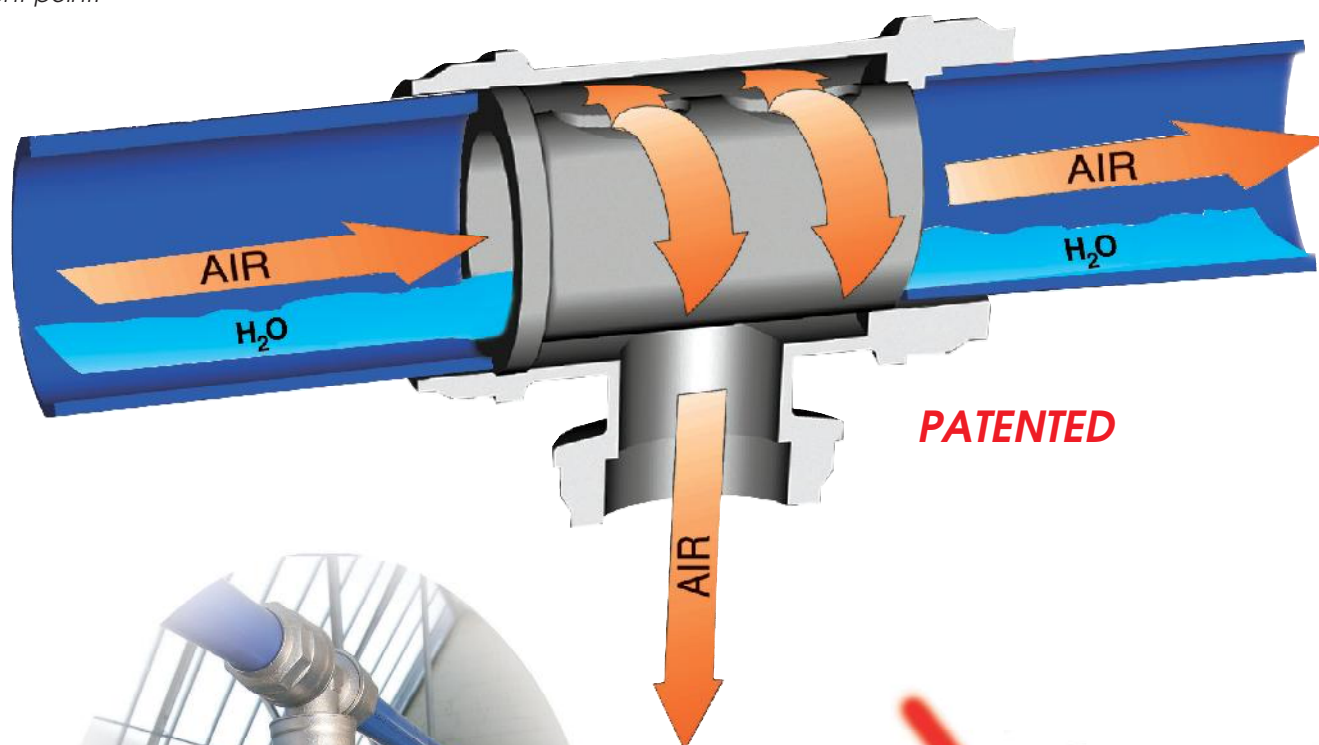
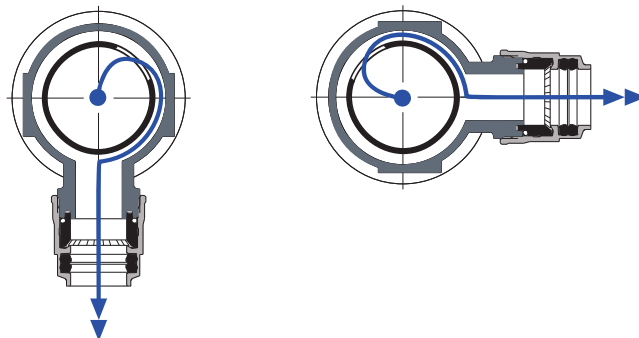

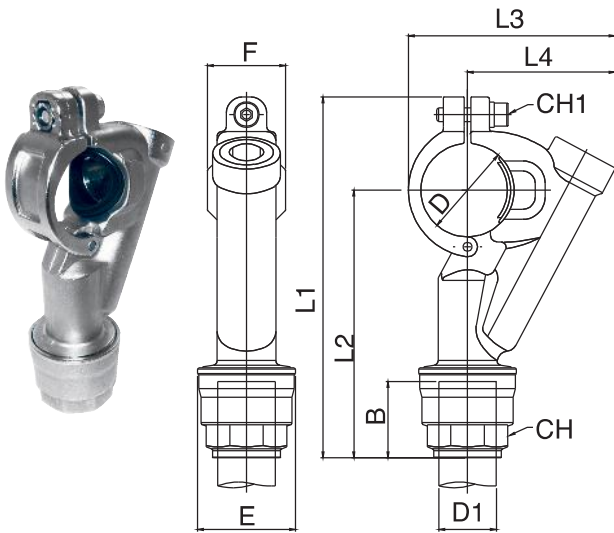

90240

FLANGIA PER CALATA - SADDLE CLAMP CONNECTOR

Codice Code	D	D1	B	E	F	L1	L2	L3	L4	CH	CH1	Conf. Pack.
9024000003	32	20	31.5	34.5	34	136.5	100.5	78	57	30	5	6
9024000004	32	25	38.5	42.5	34	144.5	108.5	78	57	35	5	6
9024000005	40	20	31.5	34.5	34	148.5	108	89.5	64	30	5	4
9024000006	40	25	38.5	42.5	34	156.5	116	89.5	64	35	5	4
9024000007	50	20	31.5	34.5	42.5	167.5	118.5	105.5	74	30	6	2
9024000008	50	25	38.5	42.5	42.5	175.5	126.5	105.5	74	35	6	1
9024000010	63	20	31.5	34.5	42.5	185	130	119	81	30	6	1
9024000011	63	25	38.5	42.5	42.5	193	138	119	81	35	6	1

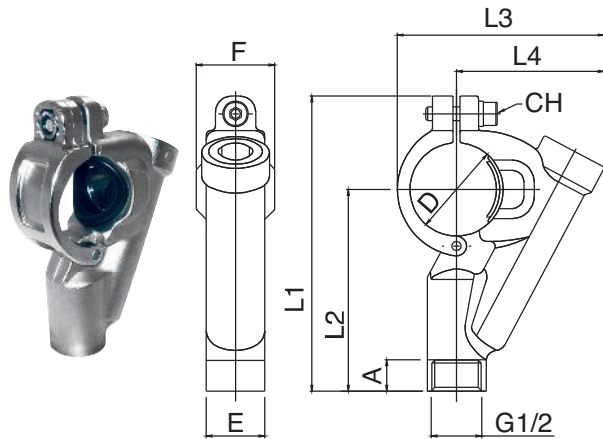
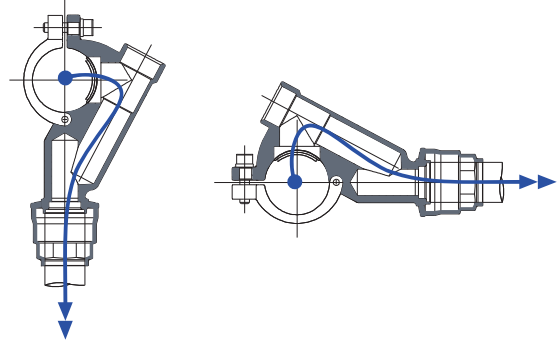

90246

FLANGIA PER CALATA FEMMINA

FEMALE SADDLE CLAMP CONNECTOR

Codice Code	D	A	E	F	L1	L2	L3	L4	CH	Conf. Pack.	
9024600003	32	1/2	13	25.5	34	115	79	78	57	5	2
9024600004	40	1/2	13	25.5	34	125.5	85	89.5	64	5	2
9024600005	50	1/2	13	25.5	42.5	144.5	95.5	105.5	74	6	2
9024600006	63	1/2	13	25.5	42.5	162	107	119	81	6	1

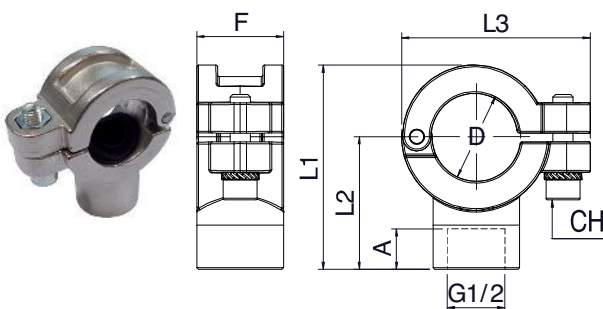
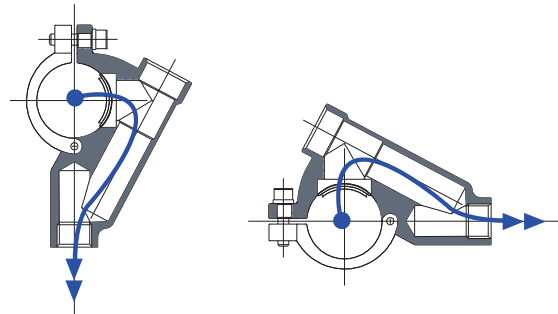

90247

FLANGIA PER CALATA FEMMINA

FEMALE SADDLE CLAMP CONNECTOR

Codice Code	D	A	F	L1	L2	L3	CH	Conf. Pack.	
9024700002	25	1/2	13	25.5	50	39	55.5	5	2
9024700004	40	1/2	13	34	71	46	70	5	2

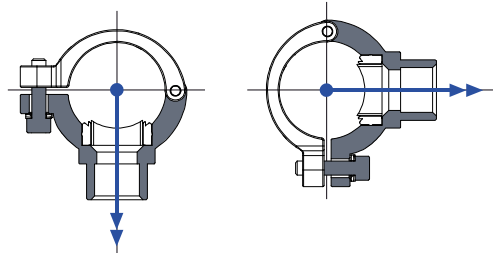

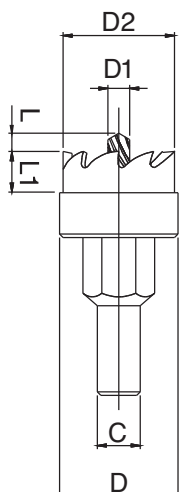

90241

FRESA PER FLANGIA DI CALATA
TOOL FOR SADDLE CLAMP CONNECTOR

Codice Code	Tubo Tube	C	D	D1	D2	L	L1	Conf. Pack.
9024100003	25	9	17.5	6	17	3	10	1
9024100001	32 40	9	24	6	23.5	3	10	1
9024100002	50 63	9	31	6	30.5	3	9	1

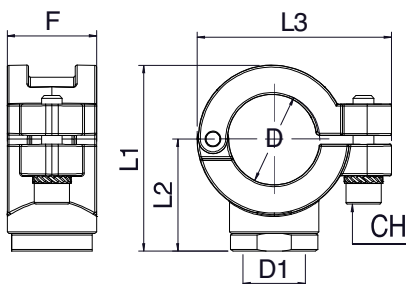

90249

DIMA PER FORATURA TUBO - DRILLINGJIG

Codice Code	D	D1	F	L1	L2	L3	CH	Conf. Pack.
9024900002	25	17.8	25.5	53	32	55.5	5	1
9024900004	40	24.5	34	65	40	70	5	1

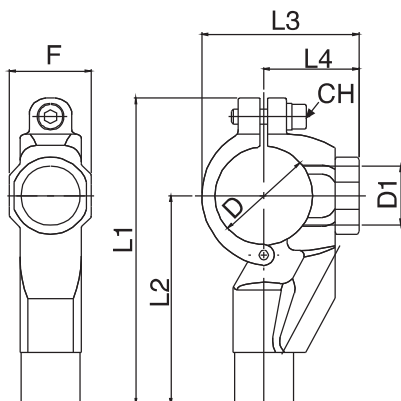

90242

DIMA PER FORATURA TUBO - DRILLINGJIG

Codice Code	D	D1	F	L1	L2	L3	L4	CH	Conf. Pack.
9024200001	32	24.5	34	115	79	56	35	5	1
9024200002	40	24.5	34	127	86.5	65	39.5	5	1
9024200003	50	32	42.5	146	97	79	47.5	6	1
9024200004	63	32	42.5	163.5	108.5	93	55	6	1

Montaggio / Installation 90240

La flangia di calata permette di realizzare una nuova calata in un impianto esistente senza rimuovere tubazioni.
Saddle clamp allows to set up a new drop in an existing system without removing tubes.



- 1** Depressurizzazione
Depressurization

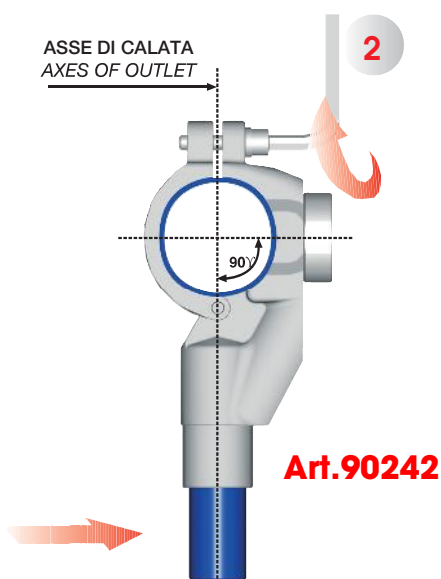

- 2** Posizionare art. 90242 sul tubo nel punto desiderato. Accertarsi che il foro di guida sia perpendicolare all'asse di calata. E' possibile inserire un tubo d20 per facilitare il posizionamento della dima.
Mount art. 90242 on tube wherever necessary. Be careful that jig bore must intersect the axis of tube drop. It is possible to connect a tube diameter 20 to take easier the positioning of the drilling jig.



- 3** Forare il tubo con utensile art. 90241
Drill the tube with proper tool art. 90241

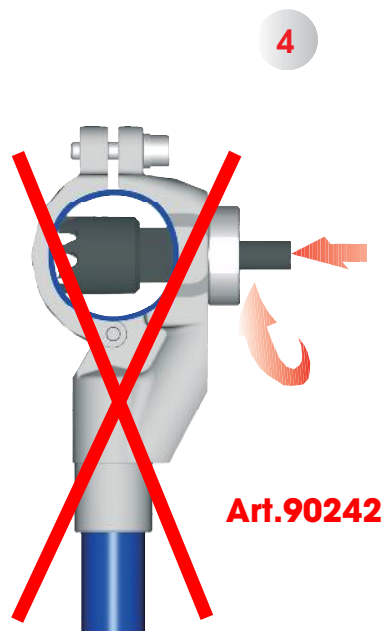

- 4** Fare attenzione a non danneggiare il tubo.
Do not damage the tube.



- 5** Smontare art. 90242 e togliere eventuali residui di materiale
Take down art. 90242 and remove residual material

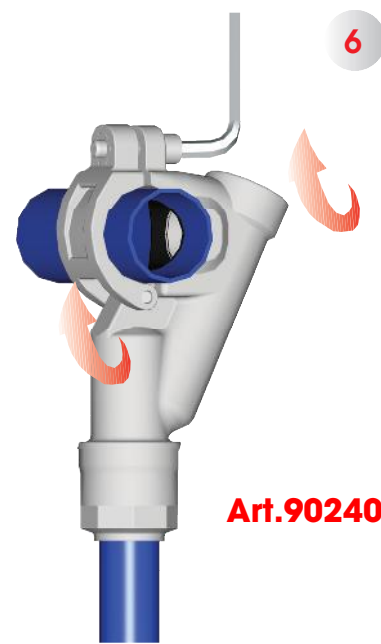

- 6** Montare e avvitare art. 90240. Fate attenzione che la guarnizione a labbro entri correttamente nel foro. Serrate la vite.
Mount and tighten art. 90240. Be careful that lipseal lays into the hole correctly. Screw up

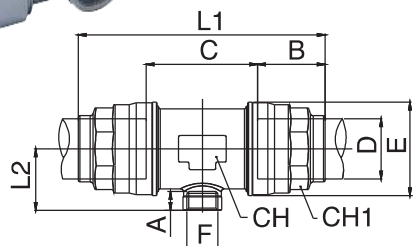

90250

NEW

RACCORDO DI SCARICO CONDENSA FEMMINA - FEMALE FITTING FOR OUTLET

Codice Code	D	F	A	B	C	E	L1	L2	CH	CH1	Conf. Pack.
9025000017A	63	1/2	13.5	57.5	88	94	203	53	80	75	1

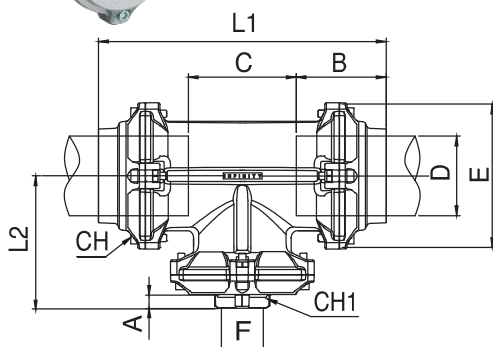

90250-80-110

NEW

RACCORDO DI SCARICO CONDENSA FEMMINA

FEMALE FITTING WITH CONDENSE EXHAUST INCORPORATED

Codice Code	D	F	A	B	C	E	L1	L2	CH	CH1	Conf. Pack.
9025000002	80	3/4	14.5	91	109	145	291.5	138	6	*42	1
9025000001	110	3/4	14.5	125.5	150.5	200	401	180	8	*42	1

*DIMENSIONI CHIAVE A SETTORE

*HOOK WRENCH DIMENSIONS

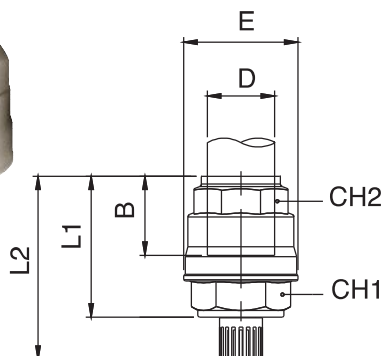

90260

RACCORDO DI SCARICO CONDENSA

FITTING WITH CONDENSE EXHAUST INCORPORATED

Codice Code	D	B	E	L1	L2	CH1	CH2	Embal. Pack.
9026000001	20	36	34.5	52.5	67	32	30	2
9026000002	25	38.5	42.5	57.5	72	32	35	2
9026000003	32	46	52	67.5	82	38	45	2
9026000004	40	52	63	77	91.5	50	55	2
9026000005	50	63.5	73	86.5	101	55	65	1
9026000006	63	59	92	84	98.5	65	70	1

*FINO AD ESAURIMENTO SCORTA

*UNTIL THE END STOCK

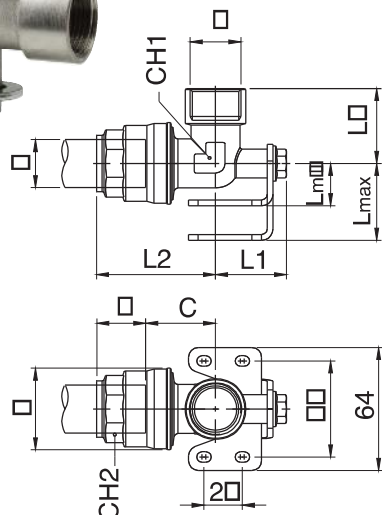

90600

RACCORDO A STAFFA - BRACKET FITTING

Codice Code	D	F	B	C	E	L1	L2	L3	Lmax	Lmin	CH1	CH2	Conf. Pack.
9060000001	20	1/2	31.5	19.5	34.5	35	51	35	40	22	21	30	4
9060000002	25	3/4	38.5	23	42.5	37	62	39	40	22	26	35	3
9060000003	32	1"	46	28	52	41	74.5	48.5	40	26	34	45	2

ORIENTABILE / ADJUSTABLE

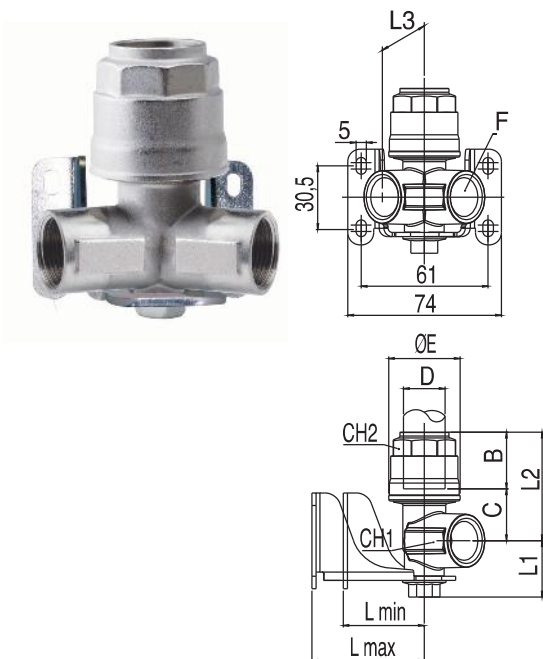

90602

RACCORDO A STAFFA - BRACKET FITTING

Codice Code	D	F	B	C	E	L1	L2	L3	Lmax	Lmin	CH1	CH2	Conf. Pack
906000001	20	1/2	31.5	19.5	34.5	35	51	35	40	22	21	30	4
906000002	25	3/4	38.5	23	42.5	37	62	39	40	22	26	35	3
906000003	32	1"	46	28	52	41	74.5	48.5	40	26	34	45	2

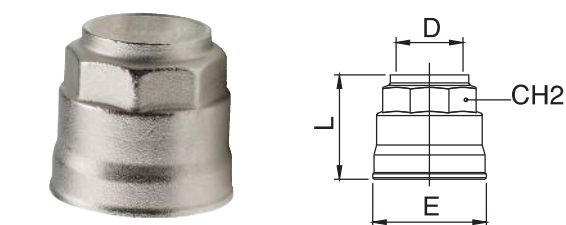
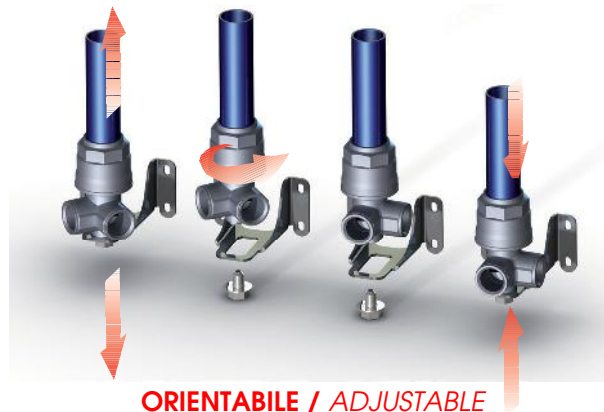

90610

TAPPO - PLUG

NEW

Codice Code	D	L	E	CH2	Conf. Pack.
906100001	20	33	34.5	30	10
906100002	25	39	42.5	35	6
906100003	32	46.5	52	45	4
906100004	40	53	63	55	4
906100005	50	62	73	65	2
*906100006	63	58	92	70	1
906100006A	63	4	94	75	1

*FINO AD ESAURIMENTO SCORTA
*UNTIL THE END STOCK

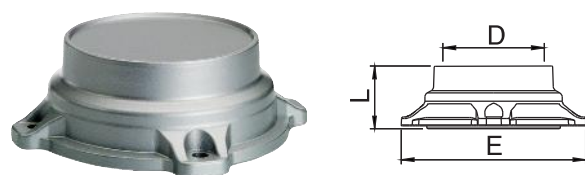

90610-80-110

TAPPO - PLUG

NEW

Codice Code	D	L	E	Conf. Pack.
906100007	80	49.5	145	1
906100008	110	68	200	1

90620

RIDUZIONE DIRITTA - REDUCING

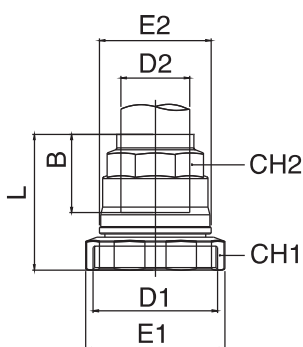

Codice Code	D1	D2	B	E1	E2	L	CH1	CH2	Conf. Pack.
9062000001	25	20	31.5	43.5	34.5	48	42	30	5
9062000002	32	20	31.5	54	34.5	48.5	52	30	5
9062000003	32	25	38.5	54	42.5	55	63	35	5
9062000004	40	20	31.5	65	34.5	50	63	30	4
9062000005	40	25	38.5	65	42.5	56.5	63	35	4
9062000006	40	32	46	65	52	63.5	63	45	3
9062000011	50	25	38.5	75	42.5	55	73	35	1
9062000007	50	32	46	75	52	63.5	73	45	1
9062000008	50	40	52	75	63	69	73	55	1
*9062000009	63	40	52	95	63	58	92	55	1
*9062000010	63	50	63.5	95	73	68	92	65	1

*FINO AD ESAURIMENTO SCORTA

*UNTIL THE END STOCK



RIMUOVERE IL DADO
REMMOVE THE NUT

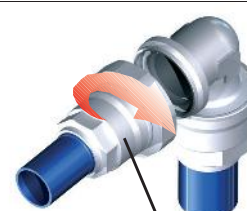

MONTARE ART. 90620
MOUNT ART. 90620

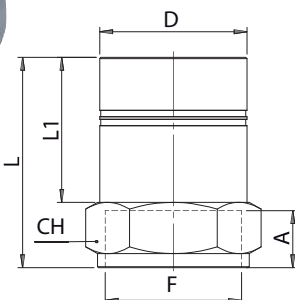

90625

RIDUZIONE FEMMINA - FEMALE REDUCING

NEW

Codice Code	D	F	A	L	L1	CH	Conf. Pack.
9062500011A	63	1"1/2	20	84	62	65	2
9062500012A	63	2"	22	90	62	65	2

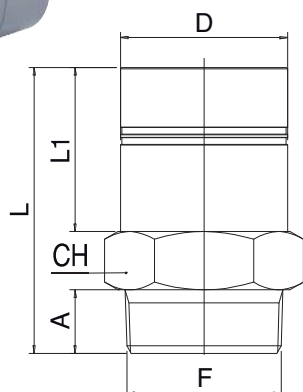

90627

RIDUZIONE MASCHIO - MALE REDUCING

NEW

Codice Code	D	F	A	L	L1	CH	Conf. Pack.
9062700011A	63	2"	24	108	62	65	2

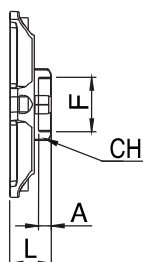

90630-80-110

RIDUZIONE FEMMINA - FEMALE REDUCING

NEW

Codice Code	D	F	A	L	CH	Conf. Pack.
9063000005	80	3/4	14.5	42	*42	1
9063000006	80	1"	17	42	*49	1
9063000007	80	1"-1/2	20	42	*66	1
9063000008	80	2"	22	42	*80	1
9063000001	110	3/4	14.5	48	*42	1
9063000002	110	1"	17	48	*49	1
9063000003	110	1"-1/2	20	48	*66	1
9063000004	110	2"	22	48	*80	1

*DIMENSIONI CHIAVE A SETTORE

*HOOK WRENCH DIMENSIONS

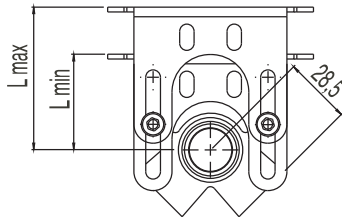
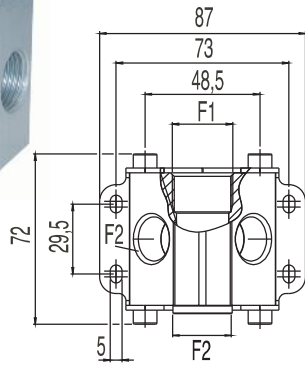

90642

RIPARTITORE 2 VIE - 2 WAYS MANIFOLD

Codice Code	F1	F2	n°	Lmax	Lmin	Conf. Pack.
9064200001	1/2	1/2	2	60	35	1
9064200002	3/4	1/2	2	60	35	1

Esempi di applicazioni / Applications example

90642
90010
661



90642
90720
661



90642
90010
6310
661



90642
90720
6310
661



90642
90010
6310
191



90642
90720
6310
191



90642
90010
191



90642
90720
191



90642
90010
2060
T100
661



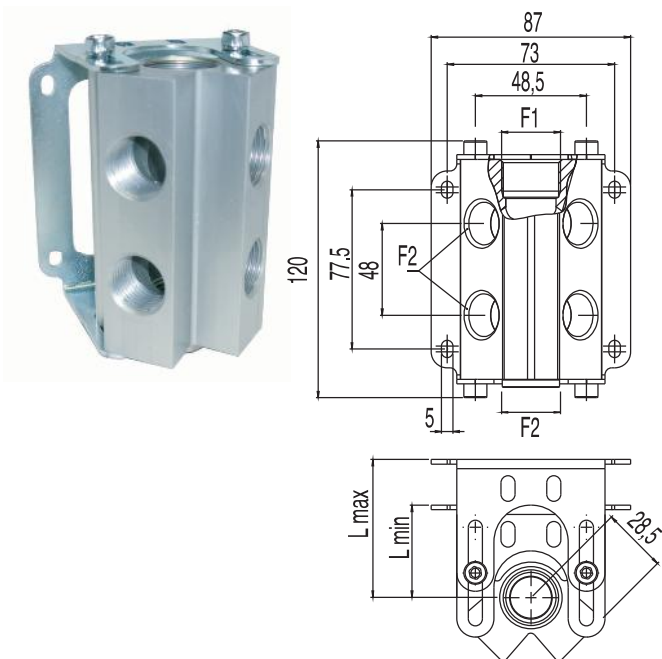

90644

RIPARTITORE 4 VIE - 4 WAYS MANIFOLD

Codice Code	F1	F2	n°	Lmax	Lmin	Conf. Pack.
906440001	1/2	1/2	4	60	35	1
906440002	3/4	1/2	4	60	35	1

Esempi di applicazioni / Applications example

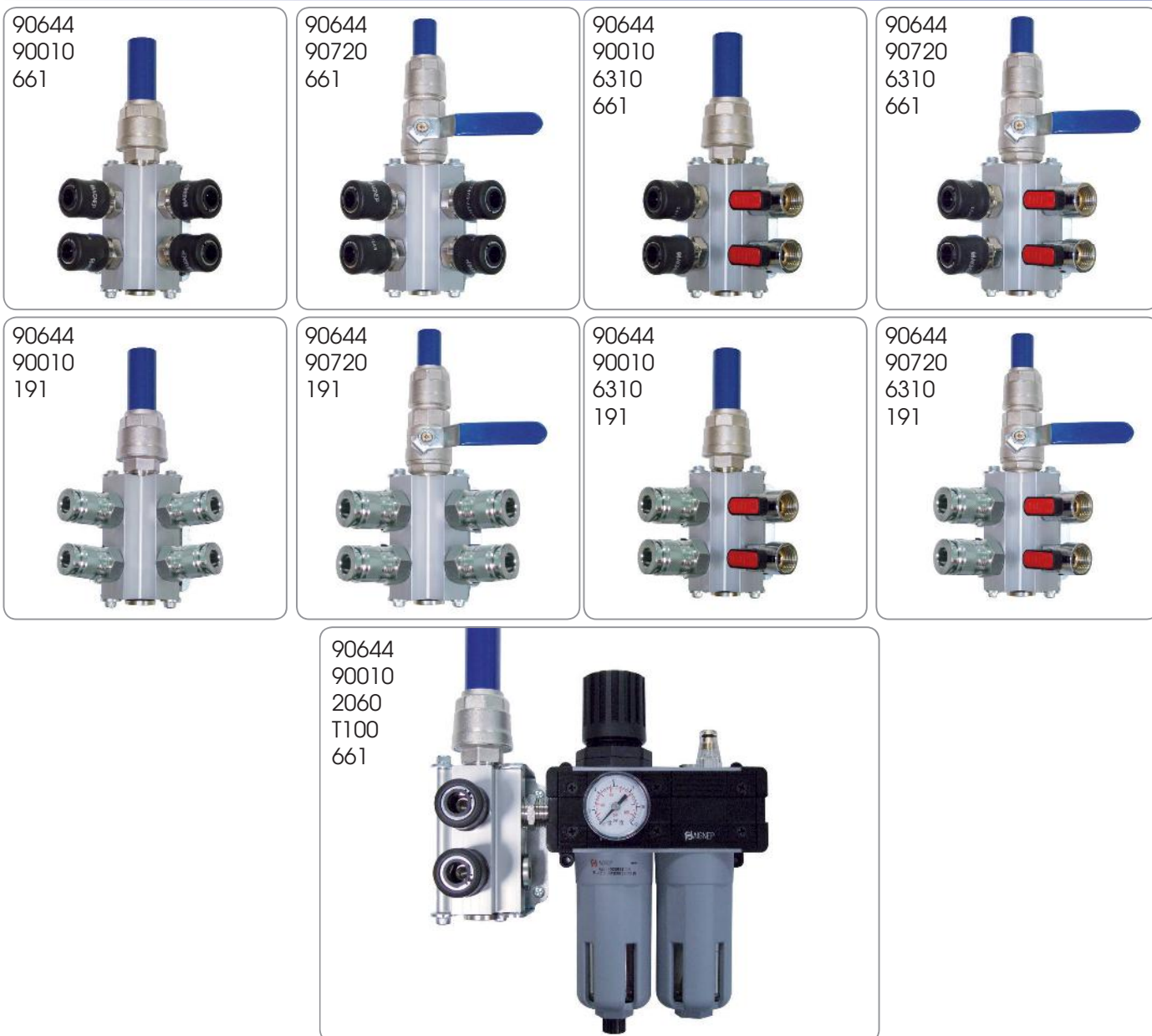

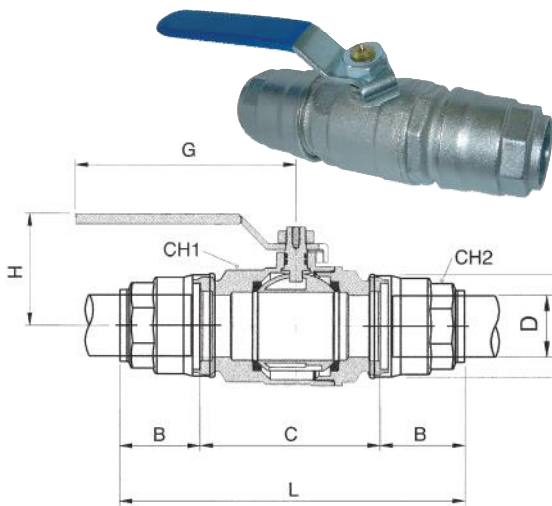

90700

VALVOLA A SFERA - BALL VALVE

NEW

Codice Code	D	DN	B	C	E	L	CH1	CH2	G	H	Conf. Pack.
9070000001	20	17	31.5	58.5	34.5	121.5	32	30	88	42	6
9070000002	25	22	38.5	61.5	42.5	138.5	41	35	106	47.5	6
9070000003	32	29	46	75	52	167	50	45	106	53	2
9070000004	40	37	52.5	81	63	186	59	55	134	65	1
9070000005	50	46	63.5	103	73	230	69	65	134	72.5	1
*9070000006	63	59	59	126	92	247	92	70	240	111.5	1
9070000006A	63	59	57.5	38	94	232	89	75	240	111.5	1

*FINO AD ESAURIMENTO SCORTA
*UNTIL THE END STOCK

VALVOLA A PASSAGGIO TOTALE
FULL FLOW RATE BALL VALVE



90710-80-110

VALVOLA A FARFALLA + VITI + DADI + RONDELLE
BUTTERFLY VALVE + SCREWS + NUTS + WASHERS

NEW

Codice Code	D	DN	A	B	C	E	F	Conf. Pack.
9071000002	80	77	87	216	46	160	210	1
9071000001	110	100	106	201	52	180	210	1

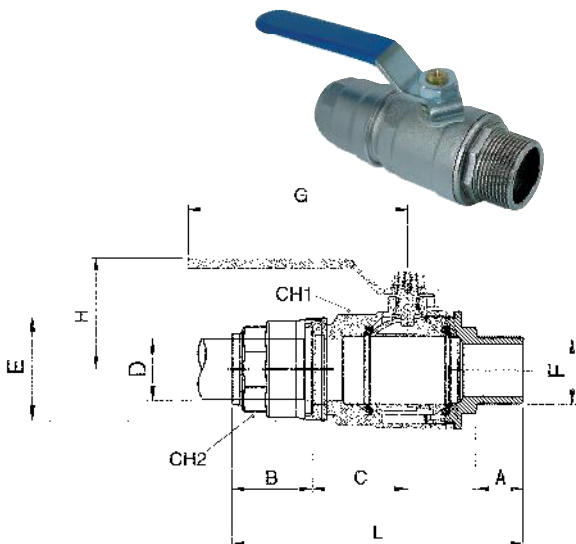
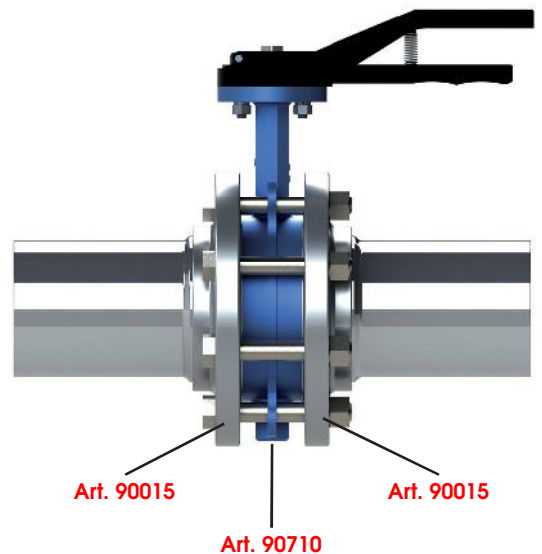
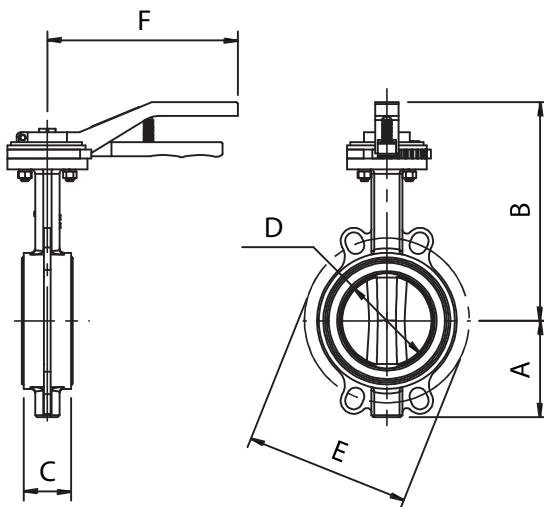

90720

VALVOLA A SFERA MASCHIO-TUBO - MALE-TUBE BALL VALVE

Codice Code	D	F	DN	A	B	C	E	L	CH1	CH2	G	H	Conf. Pack.
9072000001	20	1/2	15	18	31.5	29.3	34.5	100.8	32	30	88	42	2
9072000002	25	3/4	20	18	38.5	30.8	42.5	119.3	41	35	106	47.5	2

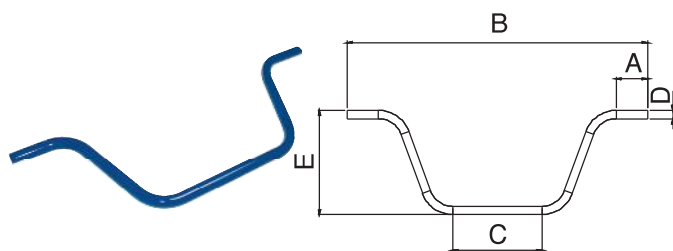

90800

TUBO EVITA OSTACOLI A C - TUBE TO AVOID OBSTACLES

Codice Code	D	A	B	C	E	Conf. Pack.
908000011Y9B5	20	75	760	254	250	1
908000011J4B5	25	75	743	240	250	1

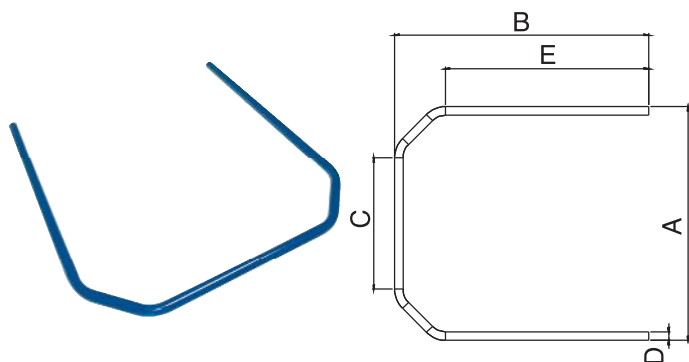

90805

TUBO EVITA OSTACOLI AD U - TUBE TO AVOID OBSTACLES

Codice Code	D	A	B	C	E	Conf. Pack.
908050011Y9B5	20	690	753	394	605	1
908050011J4B5	25	690	755	389	604	1
908050011J9B5	32	690	773	352	604	1
908050011K4B5	40	690	784	289	583	1

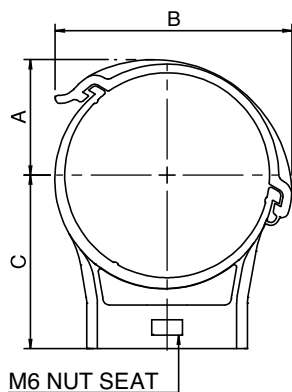

90815

COLLARI IN TECNOPOLIMERO CON DADO M6
COLLARS MADE IN TECHNOPOLYMERIC WITH M6 NUT

Codice Code	D	A	B	C	Conf. Pack.
9081500001	20	15	35.5	26	5
9081500002	25	17	39.5	26	5
9081500003	32	20	44.5	40	5
9081500004	40	24.5	53.5	40	5
9081500005	50	30	62	54	5
9081500006	63	36	73.5	54	5



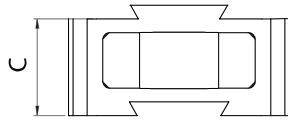

90817

DISTANZIALE PER COLLARE 90815 IN TECNOPOLIMERO
SPACER FOR COLLARS 90815 MADE IN TECHNOPOLYMERIC

Codice Code	C	Conf. Pack.
9081700001	14	5

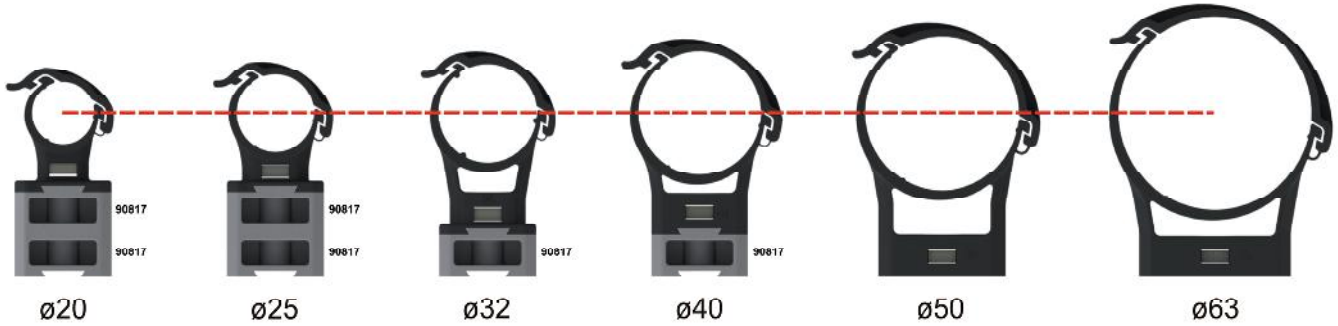

90820

COLLARI IN ACCIAIO - COLLARS MADE IN STEEL

NEW

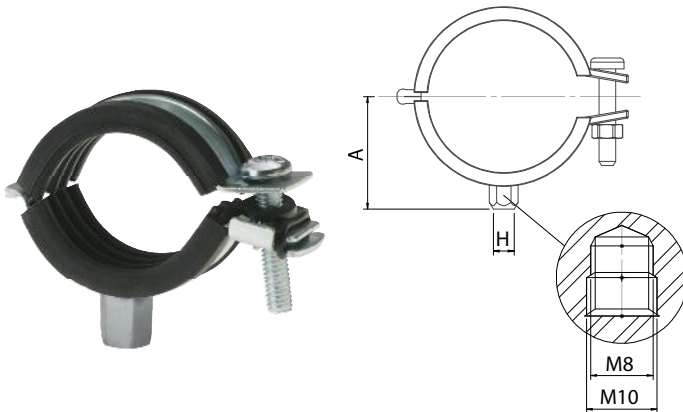

Codice Code	D	H	A	Conf. Pack.
9082000001	20	M8 / M10	28.5	5
9082000002	25	M8 / M10	31	5
9082000003	32	M8 / M10	34.5	5
9082000004	40	M8 / M10	39.5	5
9082000005	50	M8 / M10	44	5
9082000006	63	M8 / M10	51	5
9082000007	80	M8 / M10	71	4
9082000008	110	M8 / M10	81.5	2

POSIZIONAMENTO COLLARI - COLLAR POSITIONS

TUBO DA 4 MT. - 4 MT. TUBE

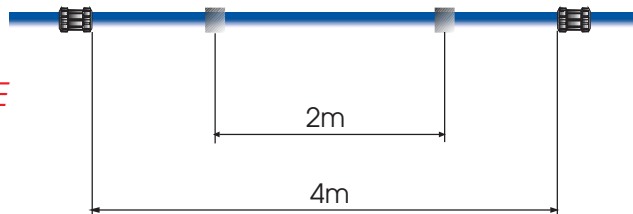

TUBO DA 6 MT. - 6 MT. TUBE

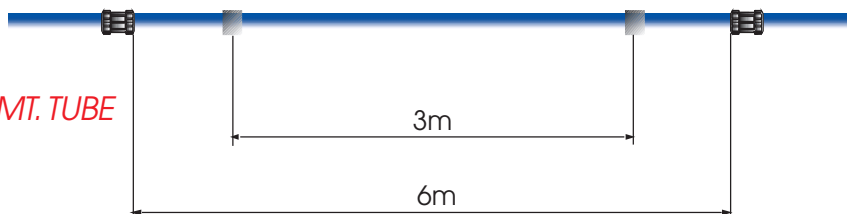

Avvolgitubo Serie Infinity / Hose Reel Infinity Serie



Art. 9082500001 9+1



Art. 9082500003 15+1

Materiali e Componenti / Component Parts and Materials

Tubo in poliuretano nero lucido
Black Polyurethane tube

Struttura in tecnopolimero
Technopolymer Structure

Staffa di fissaggio metallica orientabile
Metal Swivel Fixing Bracket

Dispositivo automatico di arresto del tubo alla lunghezza desiderata. Questo dispositivo è facilmente disinseribile, qualora si voglia il tubo costantemente in trazione.
Automatic device to stop tube at chosen length.
This device is easy to disconnect whenever you may need tube in constant traction.

Idoneo per il passaggio di aria.
Compatible with Air.





90825

AVVOLGITUBO SERIE INFINITY - HOSE REEL INFINITY SERIES

Articolo / Article	9082500001 9+1	9082500003 15+1
Tubo / Tube	Ø INT. 8mm (5/16") Ø EXT. 12mm	Ø INT. 10mm Ø EXT. 14mm
Tubo Mt. / Tube Mt.	9+1	15+1
Max. Press.	15bar (1.5Mpa)	15bar (1.5Mpa)
Temperatura Temperature	-5°/+40° C	-5°/+40° C
Raccordo in uscita Outlet Fitting	1/4 M	3/8 M
Raccordo in entrata Inlet Fitting	NO	NO
Spezzone ingresso Cut Down Size Tube	1.5 mt	1.5 mt
Aria / Air	SI	SI
Conf. / Pack.	mm 390x330x230 / Kg 4.5	mm 500x450x255 / Kg 8.0
Portata a 6 bar Flow Rate at 6 bar	450 NI/min	610 NI/min

Art. 9082500001 9+1

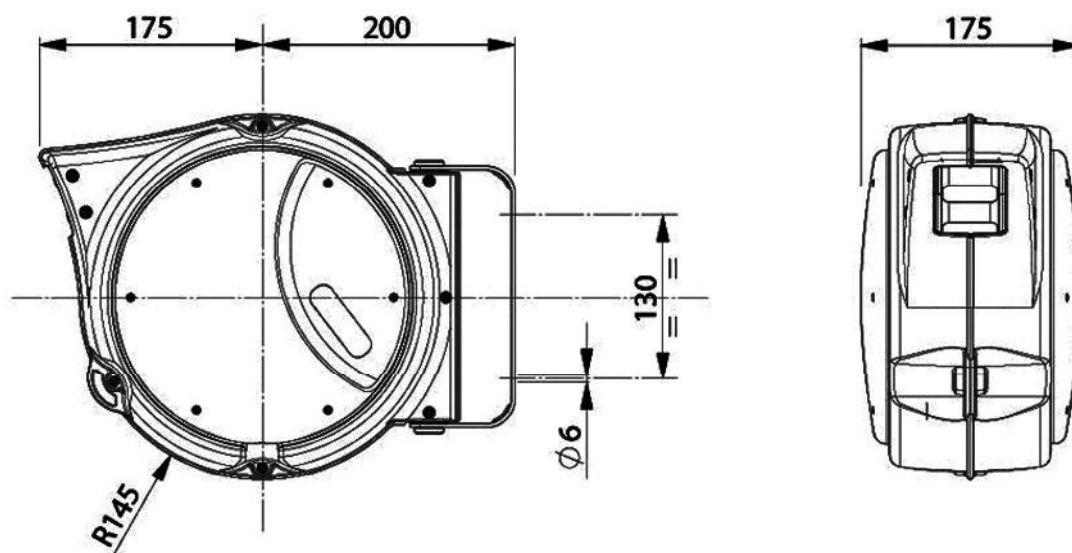

Art. 9082500003 15+1

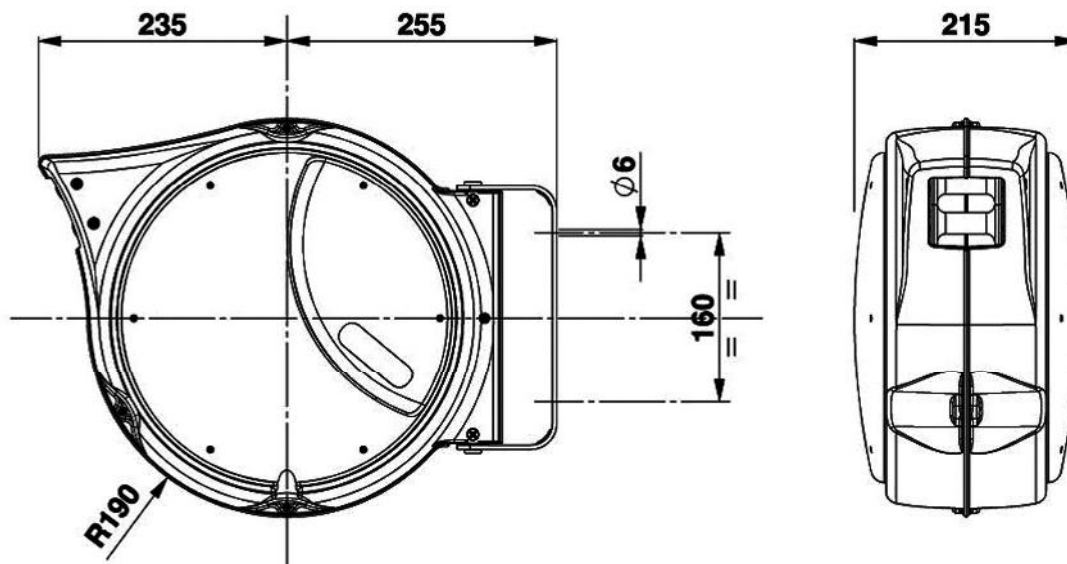

Bilanciatore con tubo spiralato Serie Infinity

Balancer with coiled tubing Infinity Serie

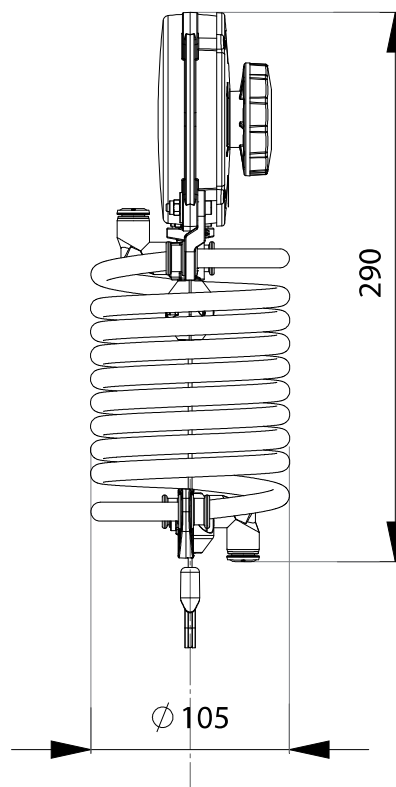
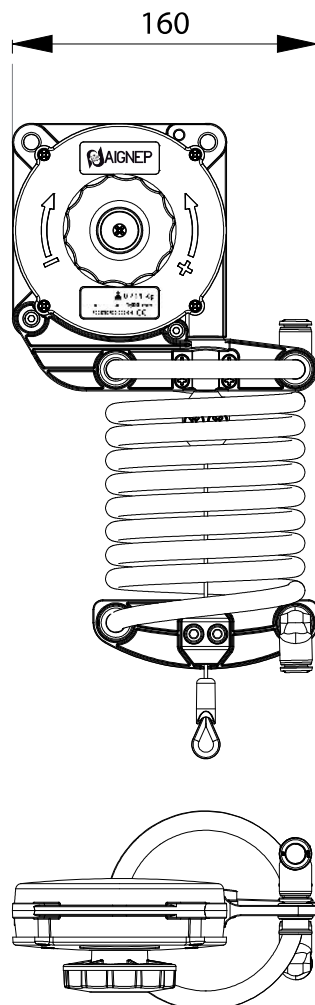

Regolazione del Carico / Adjusting the load

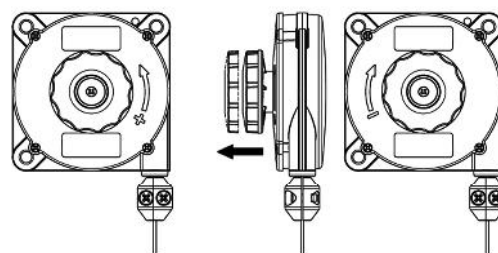

90826

BILANCIATORE CON TUBO SPIRALATO - BALANCER WITH COILED TUBING

Articolo / Article	9082600001	9082600002	9082600003
Portata kg Capacity Kg	0.4 ÷ 1	1 ÷ 2	2 ÷ 3
Cavo in acciaio Stainless steel rope	Ø 2 mm	Ø 2 mm	Ø 2 mm
Corsa Cavo Stroke Rope	1600 mm	1600 mm	1600 mm
Tubo / Tube PA12	Ø INT. 8 mm (5/16") Ø EXT. 10 mm	Ø INT. 8 mm (5/16") Ø EXT. 10 mm	Ø INT. 8 mm (5/16") Ø EXT. 10 mm
Max. Press.	10 bar (1Mpa)	10 bar (1Mpa)	10 bar (1Mpa)
Temperatura Temperature	-20°/+80° C	-20°/+80° C	-20°/+80° C
Raccordo Entrata-Uscita Inlet - Outlet Fitting	Raccordo Automatico Ø10 Push-in Fittings Ø 10	Raccordo Automatico Ø10 Push-in Fittings Ø 10	Raccordo Automatico Ø10 Push-in Fittings Ø 10
Spezzone ingresso Cut Down Size Tube	1 mt	1 mt	1 mt
Aria / Air	SI	SI	SI
Conf. / Pack.	1	1	1

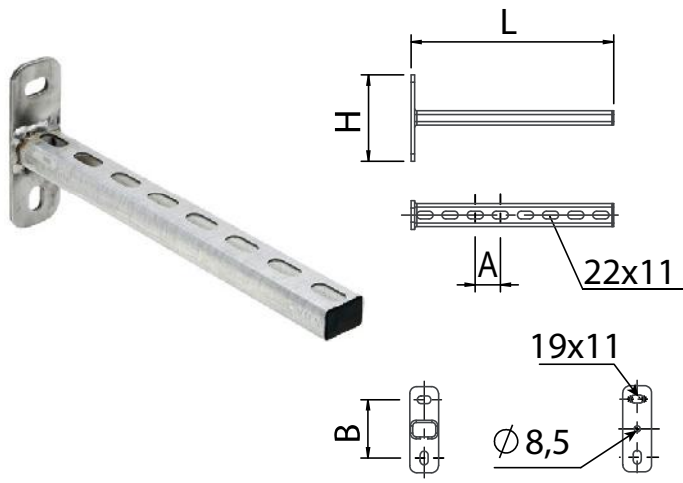

90830

MENSOLA - BRACKET

Codice Code	A	B	H	L	Conf. Pack.
9083000001	35	81	120	280	1

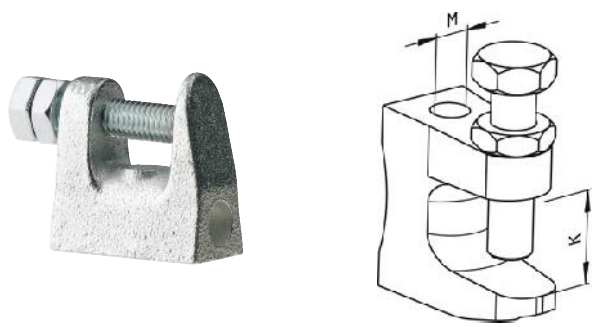

90860

MORSETTO - CLAMP HANGER

Codice Code	M	K	Conf. Pack.
9086000001	Ø9	18	1

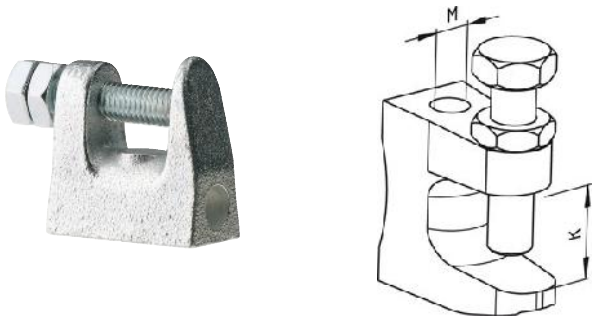

90861

MORSETTO FILETTATO - THREADED CLAMP HANGER

Codice Code	M	K	Conf. Pack.
9086100001	M8	18	1

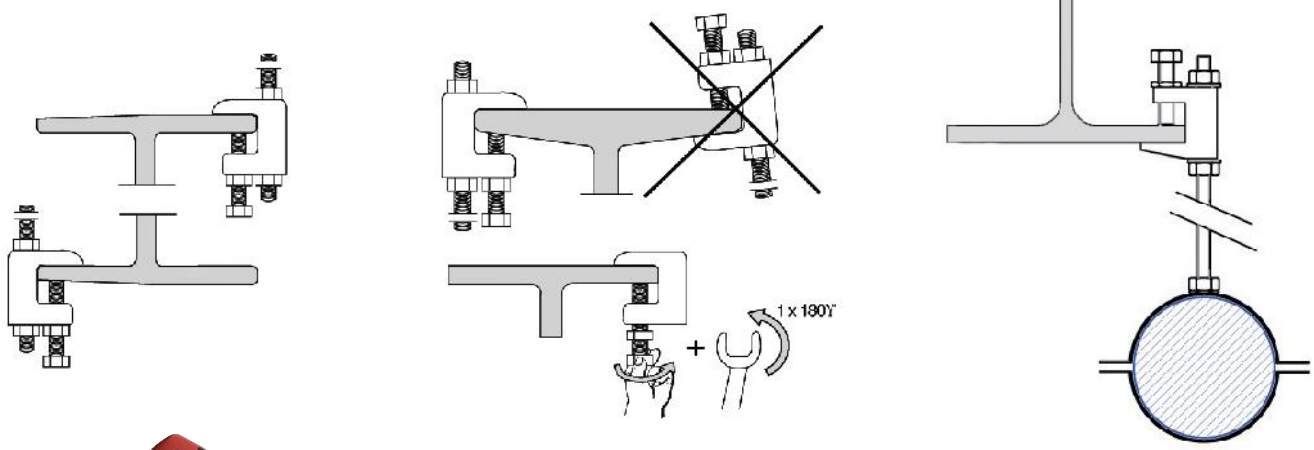

90870

TAGLIATUBO - PIPE CUTTER

Codice Code		Conf. Pack.
9087000001	20-63	1
9087000002	50-110	1



90880

SBAVATORE TUBO - DE-BURRER

Codice Code	Conf. Pack.
9088000001 20-40	1

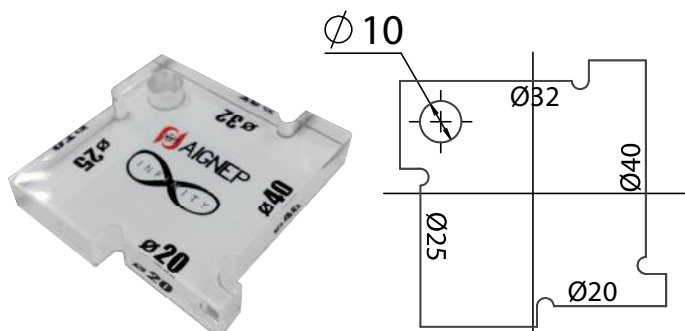

90885

DIMA SEGNA TUBO - DIMA MARK TUBE

Codice Code	Conf. Pack.
9088500001 20 - 25 - 32 - 40	1



VAL01

VALIGETTA ESPOSITIVA - DEMO CASE

Codice Code	Conf. Pack.
VAL01	1



VAL03

VALIGETTA ESPOSITIVA - DEMO CASE

Codice Code	Conf. Pack.
VAL03	1



90889

ETICHETTA ADESIVA INFINITY VACUUM - LABEL INFINITY VACUUM

Codice Cod	Conf. Pack.
9088900001	1

Accessori / Accessories

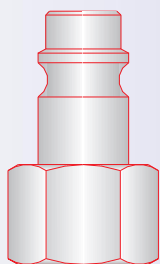

EUROPEAN
1:1

660 SERIES EUROPEAN

DN 7,8 mm



Pressione d'esercizio / Working pressure: 0 - 15 bar

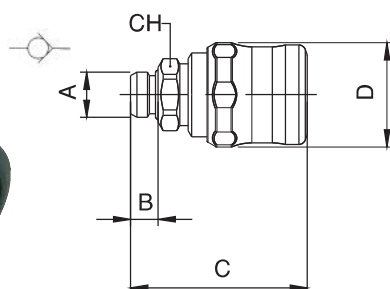

661

PRESA CON ATTACCO MASCHIO - MALE SOCKET

Codice Code	A	B	C	D	CH	Conf. Pack.
0066100001	1/4	8	51	30.5	19	10
0066100002	3/8	9	51.5	30.5	20	10
0066100003	1/2	10	52.5	30.5	25	10

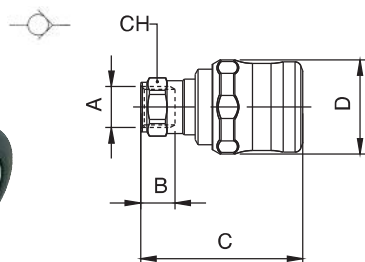

662

PRESA CON ATTACCO FEMMINA - FEMALE SOCKET

Codice Code	A	B	C	D	CH	Conf. Pack.
0066200001	1/4	11	51.5	30.5	17	10
0066200002	3/8	12	52.5	30.5	20	10
0066200003	1/2	15	55.5	30.5	24	10

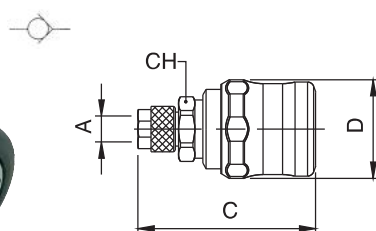

664

PRESA CON ATTACCO A CALZAMENTO - COMPRESSION SOCKET

Codice Code	A	B	C	D	CH	Conf. Pack.
0066400001	6/4	-	54.5	30.5	18	10
0066400002	8/6	-	54	30.5	18	10
0066400005	10/6.5	-	57	30.5	18	10
0066400003	10/8	-	56	30.5	18	10
0066400006	12/8	-	57.5	30.5	18	10
0066400004	12/10	-	56.5	30.5	18	10

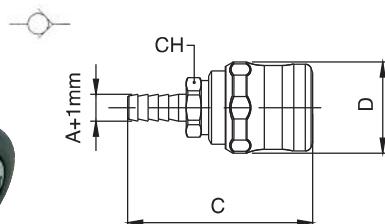

665

PRESA CON PORTAGOMMA A RESCA
SOCKET WITH BARBED CONNECTION

Codice Code	A	B	C	D	CH	Conf. Pack.
0066500001	6	-	61	30.5	18	10
0066500002	8	-	61	30.5	18	10
0066500003	10	-	61	30.5	18	10
0066500004	12	-	61	30.5	18	10



CONSULTA IL CATALOGO GENERALE, TROVERAI LA GAMMA COMPLETA.

LOOK AT THE GENERAL CATALOGUE TO FIND ALL PRODUCTS.



**ACCIAIO
STEEL**

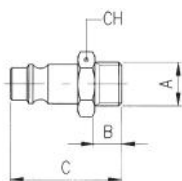

261AC

INNESTO IN AVP CON ATTACCO MASCHIO - AVP MALE PLUG

Codice Code	A	B	C	D	CH	Conf. Pack.
261AC005103ZI	1/4	8	33	-	17	25
261AC005104ZI	3/8	9	34	-	19	25
261AC005105ZI	1/2	10	35.5	-	24	25



**ACCIAIO
STEEL**

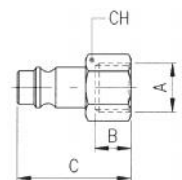

262AC

INNESTO IN AVP CON ATTACCO FEMMINA - AVP FEMALE PLUG

Codice Code	A	B	C	D	CH	Conf. Pack.
262AC005103ZI	1/4	11	33	-	17	25
262AC005104ZI	3/8	11.5	33.5	-	19	25
262AC005105ZI	1/2	14	36	-	24	25



**ACCIAIO
STEEL**

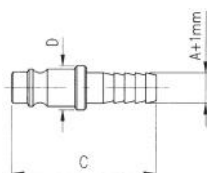

265AC

INNESTO IN AVP CON PORTAGOMMA A RESCA
AVP PLUG WITH BARBED CONNECTION

Codice Code	A	B	C	D	CH	Conf. Pack.
265AC0051X4ZI	6	-	39.5	12	-	25
265AC0051X7ZI	8	-	39.5	12	-	25
265AC0051X9ZI	10	-	42.5	14	-	25
265AC0051Y1ZI	12	-	42.5	16	-	25

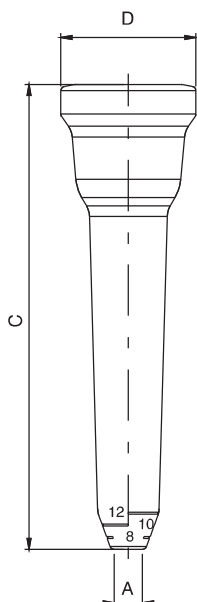

628

PROTEZIONE PRESA IN EPDM - EPDM SOCKET PROTECTION

Codice Code	A	B	C	D	CH	Conf. Pack.
0062800200000	*6 / 8 / 10 / 12	-	105	30.5	-	10

*Tagliare la protezione in corrispondenza della scritta indicante la misura del diametro esterno del tubo utilizzato.
Cut the protection on external tube diameter sign.

L'articolo 628 è particolarmente indicato per le prese con terminale portagomma Art. 665 e attacco a calzamento Art. 664.

Art. 628 Item is particularly used on socket with barbed connection and socket with compression fitting Art. 665 and Art.664.



CONSULTA IL CATALOGO GENERALE, TROVERAI LA GAMMA COMPLETA.

LOOK AT THE GENERAL CATALOGUE TO FIND ALL PRODUCTS.

RICONOSCIMENTI UFFICIALI MINISTERI ITALIANI:

- Legge 1086/71 con D.M. 27/11/89 n. 29913 "Prove sui materiali da costruzione".
- D.M. 09/11/99 "Certificazione CE per le unità di dipinto".
- D.M. 04/08/94 "Certificazione CEE sulle macchine".
- Notifica n. 757990 del 15/12/96 "Certificazione CEE per gli apparecchi a gas".
- D.M. 09/07/93 "Certificazione CEE in materia di recipienti semplici a pressione".
- D.M. 08/07/93 "Certificazione CEE concernente la sicurezza dei giocattoli".
- Incarichi di verifica della sicurezza e conformità dei prodotti nell'ambito della sorveglianza sul mercato e tutela del consumatore.
- D.M. 02/04/98 "Rilascio di attestazioni di conformità delle caratteristiche e prestazioni energetiche dei componenti degli edifici e degli impianti".
- Legge 81/84 e D.M. 26/03/85 con autorizzazione del 21/03/86 "Prove di reazione al fuoco secondo D.M. 26/06/84".
- Legge 81/84 e D.M. 26/03/85 con autorizzazione del 10/07/86 "Prove di resistenza al fuoco secondo Circolare n. 91 del 14/09/81".
- Legge 81/84 e D.M. 26/03/85 con autorizzazione del 03/07/82 "Prove di resistenza al fuoco secondo Decreto n. 7 del 02/04/91 norma CNVVF/CCI UNI 9723".
- Legge 81/84 e D.M. 26/03/85 con autorizzazione del 12/04/88 "Prove su estintori d'incendio portatili secondo D.M. 20/12/82".
- Legge 46/82 con D.M. 08/10/85 "Immissione nell'albo dei laboratori autorizzati a svolgere ricerche di carattere applicativo a favore delle piccole e medie industrie".
- Protocollo n. 118 del 27/03/87 "Iscrizione allo Schedario Anagrafe Nazionale delle ricerche con codice N.E0490Y9Y".
- Decreto 24/06/02 "Certificazione CE di rispondenza della conformità delle attrezzature a pressione".
- Decreto 14/02/02 "Certificazione CE di conformità in materia di emissione acustica ambientale per macchine e attrezzature".
- Decreto 05/02/03 "Esecuzione delle procedure di valutazione della conformità dell'equipaggiamento marittimo".
- G.U.R.I. n. 236 del 07/10/04 "Certificazione CE sugli ascensori".
- Notifica per le attività di attestazione della conformità alle norme armonizzate della Direttiva 89/106 sui prodotti da costruzione.

ENTI TERZI:

- SINCERT: Accreditiamenti n. 057A del 19/12/03 "Organismo di certificazione di sistemi di gestione per la qualità" n. 082B del 12/04/06 "Organismo di certificazione di prodotto".
- SIT: Centro multisede n. 20 (Bellaria - Pamecia) per grandezze termometriche ed elettriche.
- ICM: "Prove di laboratorio nell'ambito degli schemi di Certificazione di Prodotto".
- IMD: "Prove di laboratorio nell'ambito degli schemi di Certificazione di Prodotto per carne fumate".
- UNISAL: Riconoscimento del 26/03/95 "Laboratorio per le prove di certificazione UNISAL su serramenti a facciata continua".
- IMQ-UNI: "Prove di laboratorio nell'ambito degli schemi di Certificazione di Prodotto per termocammini a legna con fluido a circolazione forzata".
- CSI-UNI: "Prove di laboratorio in ambito degli schemi di Certificazione di Prodotto per serramenti esterni".
- KEYMARK per isolanti termici: "Misure di conduttività termica per materiali isolanti".
- IT: "Prove di laboratorio e sorveglianza in azienda nell'ambito degli schemi di Certificazione di Prodotto per porte, finestre, chiusure occorrenti (antifurtive) e serramenti".
- EFSG: "Prove di laboratorio su cassetti e altri mezzi di custodia".
- AENOR: "Valutazione della conformità ai fini della marcatura CE per alcuni prodotti inerti la direttiva prodotti da costruzione".
- VIT-Finlandia: "Valutazione della conformità ai fini della marcatura CE per alcuni prodotti inerti la direttiva prodotti da costruzione".
- C.C.I.A.A. Rimini: 28/01/04 "Verifica periodica dell'affidabilità metrologica di strumenti metro in materia di commercio".

PARTECIPAZIONI ASSOCIATIVE:

- AIA: Associazione Italiana di Acustica.
- AIGARR: Associazione Italiana Condizionamento dell'Aria Riscaldamento Refrigerazione.
- AICO: Associazione Italiana per la Qualità.
- AIPID: Associazione Italiana Prove non Distruttive.
- ALP: Associazione Laboratori Italiani Fuoco.
- ALPI: Associazione Laboratori di Prova indipendenti.
- ASHRAE: American Society of Heating, Refrigerating and AirConditioning Engineers Inc.
- ASTM: American Society for Testing and Materials.
- ATIG: Associazione Tecnica Italiana del Gas.
- CTE: Collegio dei Tecnici della Industrializzazione Edilizia.
- CTE: Comitato Termotecnico Italiano.
- EARMA: European Association of Research Managers and Administrators.
- EARTO: European Association of Research and Technology Organisation.
- EGOLF: European Group of Official Laboratories for Fire Testing.
- UNI: Ente Nazionale Italiano di Unificazione.

CLAUSOLE:

Il presente documento si riferisce solamente al campione o materiale sottoposto a prova.
Il presente documento non può essere riprodotto parzialmente, salvo approvazione scritta del laboratorio.

ABRIDGED TEST REPORT No. 238763
(Refers to test report No. 236272 issued by this Institute on 07/02/2008)

Place and date of issue: Bellaria-Igea Marina - Italy, 07/04/2008

Customer: AIGNEP S.p.A. - Via Industriale, 1 - 25070 BIONE (BS) - Italy

Date test requested: 09/11/2007

Order number and date: 39092, 09/11/2007

Date specimen received: 20/11/2007

Date test effected: from 20/12/2007 to 08/01/2008

Purpose of test: Testing copper-alloy quick-action couplings for use with aluminium tubes

Test site: Istituto Giordano S.p.A. - Blocco 1 - Via Rossini, 2 - 47814 Bellaria-Igea Marina (RN) - Italy

Specimen origin: sampled and supplied by Customer

Identification of specimen received: No. 2007/2505

Description of specimen

The test specimens are known as "Raccordi ad innesto rapido per tubazioni in alluminio Serie 90.000" ("Copper-alloy quick-action couplings for use with aluminium tubes Series 90.000"), DN 110.

Result of test

The tests listed below, agreed with the Customer and, in the absence of specific standards, conducted in accordance with standard UNI EN 1254-2:2000, gave the following results:

- leaktightness under internal pneumatic pressure: No visible signs of leakage;
- bursting strength test: 51 bar;
- resistance to pull-out: maximum axial movement 0,49 mm and no visible leakage in the subsequent pneumatic pressure test;
- leaktightness under internal hydraulic pressure whilst subjected to bending: no visible signs of leakage or damage.

As regards the description of the specimen, normative references, test methods, test equipment, test results and everything else necessary for the identification of the work carried out, please see Test Report No. 236272 issued by this Institute on 07/02/2008.

Test Technician (Per. Ind. Walter Frattini) Manager, Applied Physics Laboratory (Dott. Ing. Vincenzo Iommi) Chairman or Managing Director (Dott. Ing. Vincenzo Iommi)

Comp. AV
Revis:

This abridged report consists of 1 sheet
This document is the English translation of the abridged test report No. 238763 of 07/04/2008 issued in Italian.
Date of translation: 07/04/2008.

Sheet 1 of 1

RISULTATI ESTRATTI DAL RAPPORTO DI PROVA N° 189076, N° 236272 E N° 312056 DELL' ISTITUTO GIORDANO
OUTCOME OF THE TEST NR.189076, NR. 236272 AND N° 312056 OF GIORDANO INSTITUT.

Prodotto:

Sistema di distribuzione aria Infinity composto da:

- tubi in alluminio calibrato
- raccordi automatici in ottone con pinza di aggraffaggio in acciaio e componenti in tecnopolimero e guarnizioni in NBR.

Product:

Air distribution system consisting of:

- *tubes in gauged aluminium*
- *push-in fittings in brass with clamping washer in steel and tecnopolymeric parts with seal in NBR.*

Prova eseguita: Verifica della tenuta sotto pressione a 1,5 volte la pressione Max dichiarata.

Test: *Test of pressure 1.5 time higher of the max declared.*

Diametro nominale raccordi e tubo in alluminio <i>Diameter Fittings and tube</i>	Verifica tenuta pneumatica a 22,5 bar (1,5 PN) per 15 minuti <i>Pneumatic resistance at 22,5 bar (1,5 PN) for 15 minute</i>	Verifica tenuta pneumatica a 0,5 bar per 15 minuti <i>Pneumatic resistance at 0,5 bar for 15 minute</i>
DN 20 DN 25 DN 32 DN 40 DN 50 DN 63 DN63 (Alluminio <i>Aluminium</i>) DN110	*Nessuna perdita visibile *No visible leakage	*Nessuna perdita visibile *No visible leakage

Prova eseguita: Verifica della pressione di scoppio.

Test: *Pressure of explosion.*

Diametro nominale raccordi e tubo in alluminio <i>Diameter Fittings and tube</i>	Pressione idraulica di rottura <i>Hydraulic pressure of breaking</i>
DN 20	Alla pressione di 115 bar si è avuto un parziale sfilamento del tubo da un raccordo, con perdita di notevole entità. <i>Pressure 115 bar unthreading of a fitting from the tube with leakage.</i>
DN 25	Alla pressione di 75 bar si è prodotto lo sfilamento totale del tubo da un raccordo. <i>Complete unthreading pressure 75 bar of a tube.</i>
DN 32	Alla pressione di 78 bar è iniziato lo sfilamento del tubo da un raccordo, con tenuta idraulica: a 93 bar si è prodotto lo sfilamento completo. <i>At 78 bar unthreading of a tube with wet seal: at 93 total unthreading.</i>
DN 40	Alla pressione di 75 bar il tubo ha iniziato a sfilarsi da un raccordo: mentre si cercava di mantenere/innalzare il valore della pressione, si è prodotto lo sfilamento totale del tubo dal raccordo. <i>At 75 bar the tube becomes unthreaded while trying to increase the pressure.</i>
DN 50	Alla pressione di 58 bar il tubo ha iniziato a sfilarsi da un raccordo: lo sfilamento progressivo e la successiva perdita non hanno permesso di innalzare ulteriormente la pressione. <i>At 58 bar the tube has become unthreaded.</i>
DN 63	Alla pressione di 62 bar si è manifestata una perdita, la cui entità è aumentata senza permettere un ulteriore innalzamento della pressione. <i>At 62 bar, leakage, no possibility to increase pressure.</i>
DN63 (Alluminio <i>Aluminium</i>)	Alla pressione di 58 bar il tubo ha iniziato a sfilarsi da un raccordo: lo sfilamento progressivo e la successiva perdita non hanno permesso di innalzare ulteriormente la pressione. <i>At 58 bar the tube has become unthreaded.</i>
DN 110	Alla pressione di 36 bar si è manifestata una perdita. <i>At 36 bar, leakage.</i>

Prova eseguita:

Prove di trazione a carico costante secondo la **Norma UNI-EN 1254-2:2000 punto 5.5.**

Test:

*Constant tensile stress in accordance with **Norma UNI-EN 1254-2:2000 punto 5.5.***

Diametro nominale raccordi e tubo in alluminio <i>Diameter Fittings and tube</i>	Carico di trazione applicato (N) <i>Power of stress (N)</i>	Sfilamento massimo del tubo dai raccordi (mm) <i>Unthreading of tubes (mm)</i>	Verifica tenuta pneumatica a 6 bar <i>Resistance at 6 bar</i>
DN 20	1500	0,9	*Nessuna perdita visibile <i>*No visible leakage</i>
DN 25	1500	0,4	
DN 32	2000	0,4	
DN 40	2000	0	
DN 50	2000	0	
DN 63	2500	0	
DN63 (Alluminio <i>Aluminum</i>)	2500	0	
DN 110	2500	0,49	

Prova eseguita:

Verifica della tenuta sotto pressione pneumatica interna e contemporanea applicazione di sollecitazione a flessione, come **Norma UNI-EN 1254-2:2000 punto 5.6.**

Prova eseguita:

Test:

*Resistance under pneumatic internal pressure and bending stress at the same time according to **Norma UNI-EN 1254-2:2000 punto 5.6.***

Diametro nominale raccordi e tubo in alluminio <i>Diameter Fittings and tube</i>	Distanza tra i centri dei supporti applicato (mm) <i>Distance between bearing points</i>	Pressione pneumatica interna di prova <i>Pneumatic pressure</i>	Verifica resistenza meccanica e tenuta pneumatica (bar) <i>Resistance and pneumatic stamina</i>
DN 20	1800	10	*Nessuna perdita visibile <i>*No visible leakage</i>
DN 25	1800	10	
DN 32	1800	10	
DN 40	2400	10	
DN 50	2700	10	
DN 63	3000	6	
DN63 (Alluminio <i>Aluminum</i>)	3000	6	
DN 110	3000	6	

Il certificato che riporta tutti i dettagli e modalità delle prove può essere richiesto.
The certificate is available upon request.

DICHIARAZIONE DI CONFORMITA' PER GLI IMPIANTI DI DISTRIBUZIONE DELL'ARIA.

CONFORMITY DECLARATION FOR THE DISTRIBUTION OF COMPRESSED-AIR.

Dichiariamo che il sistema di distribuzione dell'aria alle seguenti condizioni di utilizzo: pressione $-0,99 \div 16$ bar - temperatura $-20^{\circ}\text{C} \div 80^{\circ}\text{C}$ soddisfa la **direttiva 97/23/CE Art. 3.3 (PED: Pressure Equipment Directive)**

We declare that the system used with pressure $0.99 \div 16$ bar and temperature $-20^{\circ}\text{C} \div 80^{\circ}\text{C}$ with **directive 97/23/CE Art. 3.3 (PED: Pressure Equipment Directive)**.

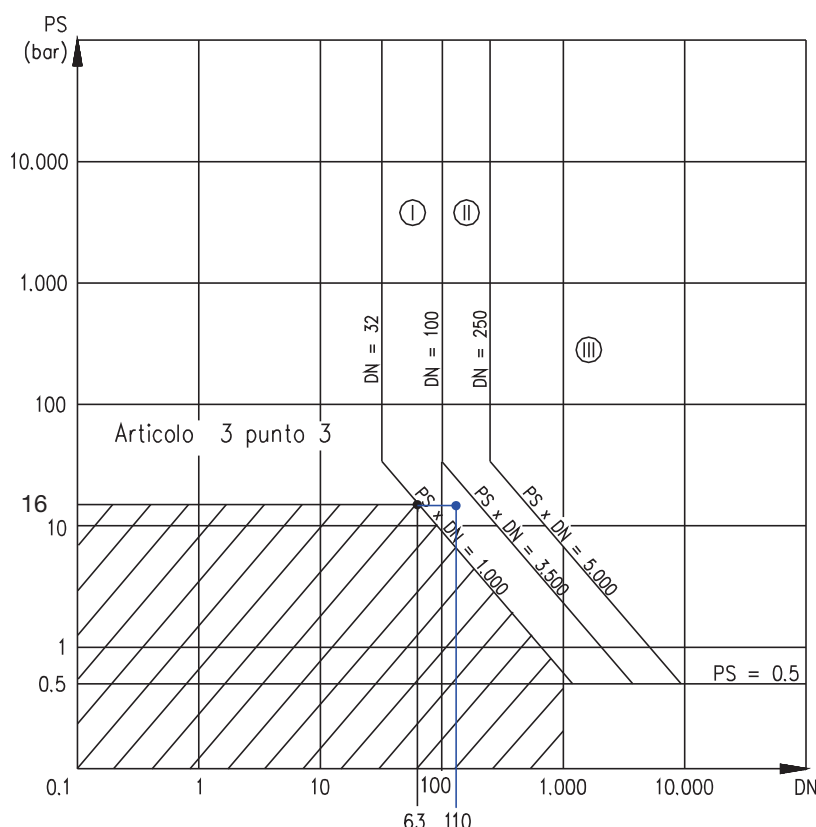

Prendendo in considerazione il diametro interno per DN63 e la pressione massima di 16 bar, si osserva nel grafico, che il punto di intersezione $PS \times DN = 16 \times 59 = 944$ è alla sinistra della zona $PS \times DN = 1.000$: zona esente dalla marcatura CE secondo la direttiva menzionata (Art.3.3). Quindi in base alla direttiva **97/23/CE Art. 3.3** per tutti i tubi e i relativi raccordi ($\varnothing 20$ - $\varnothing 25$ - $\varnothing 32$ - $\varnothing 40$ - $\varnothing 50$ - $\varnothing 63$) che costituiscono gli impianti di distribuzione dell'aria Infinity non è necessaria la marcatura CE.

Prendendo in considerazione il diametro interno per DN110 e la pressione massima di 16 bar, si osserva nel grafico, che il punto d'intersezione $PS \times DN = 16 \times 105 = 1680$ è nella zona individuata come categoria I. In base alla direttiva 97/23/CE per tale zona si prevede la valutazione della conformità secondo un controllo di fabbricazione interno.

Considering the internal diameter for DN63 and max pressure 16 bar, on can see on the graphic that the intersection point $PS \times DN = 16 \times 59 = 944$ is on the left side of zone $PS \times DN = 1.000$: it meas is exempt from **CEE** marking according to the above mantioned directive (Art.3.3). Therefore all tubes and fitting ($\varnothing 20$ - $\varnothing 25$ - $\varnothing 32$ - $\varnothing 40$ - $\varnothing 50$ - $\varnothing 63$) do not require any **CEE** marking.

Considering the internal diameter for DN110 and maximum pressure of 16 bar, the intersection point $PS \times DN = 16 \times 105 = 1680$ in the chart above, is in the area called "CATEGORIA I". According to Directive 97/23/CE this area has a conformity evaluation made at factory.

CONFORMITA' DEL PROCESSO DI VERNICIATURA A POLVERE POLIESTERE SU TUBI DI ALLUMINIO DELLA SERIE INFINITY

CONFORMITY OF POLYESTER POWDER PAINTING ON ALUMINIUM TUBES OF SERIE INFINITY.

- PRETRATTAMENTO

Garantisce l'ancoraggio della vernice all'alluminio e ne previene la corrosione e l'ossidazione delle parti non verniciate. E' conforme alle seguenti normative tecniche: **UNI 9921 - DIN 50939 - ASTM D 1730 - MIL C 5541**

- PRE-TREATMENT.

*It guarantees the anchorage of the painting to the tube and prevents corrosion and oxydation of not painted parts according to: **UNI 9921 - DIN 50939 - ASTM D 1730 - MIL C 5541.***

- VERNICIATURA

E' effettuata utilizzando vernice in polvere poliestere atossica certificata QUALICOT e GSB in conformita' alle seguenti normative: **UNI 9983 - BS 6496 - AAMA 603-605**

I sopradescritti trattamenti rendono inattaccabile alla corrosione in ambienti marini la parte esterna dei tubi, in quanto completamente ricoperta di vernice. La parte interna solamente pretrattata (cromatata) offre comunque una discreta protezione.

- PAINTING.

*Made using powder painting not-toxic certified QUALICOT and GSB according to: **UNI 9983 - BS 6496 - AAMA 603-605.** The above mentioned treatments prevents corrosion to external part. Inside is treated with chrome.*



**CONFORMITA' ALLA TENUTA AL FUOCO
RESISTANCE TO FIRE.**

Oggetto:

Classificazione resistenza al fuoco di prodotti e componenti, sulla base dei risultati delle prove di reazione al fuoco secondo **UNI EN 13501-1:2005.**

Descrizione prodotto:

Tubo di alluminio verniciato Serie 90000

La classificazione è determinata dall'analisi del calore di combustione della vernice in combinazione con i risultati dei test specificati in **UNI EN ISO 13823** su lamine piatte equivalenti per spessore di alluminio e di vernice.

Risultato Test:

Il prodotto sottoposto al test è riconosciuto come prodotto di **Classe A2 - d1 - d0** alla resistenza al fuoco.

Subject:

*Fire classification of construction products and building elements, based on the result of reaction to fire testing in accordance with **UNI EN 13501-1:2005.***

Description of the product:

Painted aluminium pipe 90000 SERIES.

*Classification was determined by analysis of the paint's gross heat of combustion, coupled with test result as specified in **UNI EN 13823** on equivalent flat sheets, having the same thickness of aluminium and paint as the pipe.*

Test Result:

*The product under test has been awarded reaction to **Fire Class A2 - d1 - d0**, in accordance with test result obtained.*



www.infinitypipework.co.uk
sales@infinitypipework.co.uk
T: +44 01404 548000
F: +44 01404 548005

JUNE 2014