



**PNEUMATIC  
Tube Fittings  
BROCHURE**

***The Drallim Group***  
*Leading innovators in technology and quality*

DCB0006-ISS-02

## Product Range

BRASS FITTINGS

PLASTIC FITTINGS

P.T.F.E. FITTINGS

STAINLESS STEEL FITTINGS

MINIATURE CONTROL VALVES

TOGGLE VALVES

PLASTIC TUBING

PLASTIC MANIFOLDS

## BRASS TUBE FITTINGS

IMPERIAL &amp; METRIC SIZES

This range of brass and stainless steel tube couplings is offered with the Drallim resilient captive seal or a brass metal compression olive. (Couplings are supplied complete with nuts and sealing rings.)

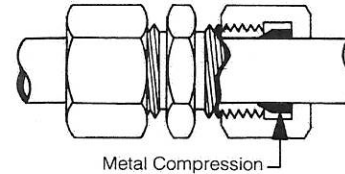

Metal Compression

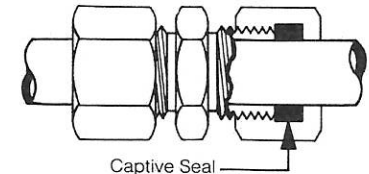

Captive Seal

Each of the coupling types is given a coding number according to the following chart, and these basic type codings are suffixed with numbers to designate the tube diameter and then the stud thread sizes where applicable.

All dimensions shown within this catalogue are approximate. Also, in the interests of technical progress, the company reserves the right to make design and manufacturing changes.

CODE	TYPE
10	Straight
20	Equal Elbow
30	Equal Tee
40	Equal Cross
50	Reducing
60	Stud par. male
70	Stud taper male
80	Stud par. female
90	Bulkhead
95	Locknut
100	Adaptor male to female
110	Adaptor female to female
120	Union Nut
130	Blanking Cap Knurled
140	Union Nut Knurled
150	Unequal Elbow
160	Stud Elbow par. male
165	Stud Elbow taper male
170	Stud Elbow female
180	Unequal Tee
190	Brass Olive
190	Copper Ferrule
200	Nylon Washer
210	Stud Tee par. male
215	Stud Tee taper male
220	
230	
300	Spigot Adaptor par. male
310	Spigot Adaptor taper male
320	Spigot Adaptor par. female
330	Spigot Coupling Adaptor
340	Tube Insert
350	Tube Clip
360	Blanking Plug male

CODE	STUD THREAD
1	1/8" B.S.P.
2	1/4" B.S.P.
3	3/8" B.S.P.
4	1/2" B.S.P.
14	5/8" B.S.P.
15	3/4" B.S.P.
5	1/8" N.P.T.
6	1/4" N.P.T.
7	3/8" N.P.T.
8	1/2" N.P.T.
9	1/8" B.S.P.T.
11	1/4" B.S.P.T.
12	3/8" B.S.P.T.
13	1/2" B.S.P.T.

CODE	TUBE SIZE
004	Ø 4mm
005	Ø 5mm
006	Ø 6mm
008	Ø 8mm
010	Ø 10mm
012	Ø 12mm
R	1/8" O/D
A	3/16" O/D
B	1/4" O/D
C	5/16" O/D
D	3/8" O/D
F	1/2" O/D
H	5/8" O/D
J	3/4" O/D

**IMPORTANT:** When ordering, codings should be prefixed either 'L' for captive seals, or 'M' for metal compression as shown in following examples. Stainless steel couplings should also have SS inserted after part number.

**EXAMPLES:** Ø12mm x 3/8" B.S.P. Stud Parallel Male Coupling with captive seal nut: L60/012/3  
1/4" O/D x 1/4" B.S.P.T. Stud Taper Male with metal compression nut: M70/B/11

FOR TECHNICAL DATA:  
REFER TO PUBLICATION TD502/1

MATERIAL SPEC:  
CAPTIVE SEAL FOR BRASS RANGE: — NITRILE.  
CAPTIVE SEAL FOR STAINLESS RANGE: — VITON.

PIPES: We recommend that the following pipe grades should be used  
Copper: BS.2871 Part 2 1972 Table 2 C106.  
Nylon: BS.5409 Part 1 1976 Types 11 & 12 Table 2.

ASSEMBLY: Couplings should be tightened finger tight plus between half and one full turn.

**BRASS TUBE FITTINGS**

IMPERIAL &amp; METRIC SIZES

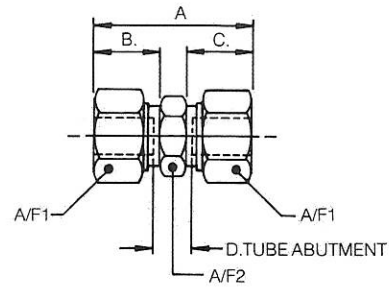
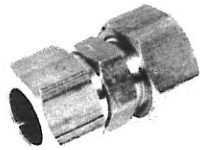
**Straight Coupling**

IMPERIAL		FOR CAPTIVE SEALS – Prefix Pt. No. L FOR METAL COMP. – Prefix Pt. No. M					
TUBE O/D.	PART NUMBER	A	B	C	D	A/F1	A/F2
1/8	10/R	1.3/64	7/16	7/16	7/64	.375	.375
3/16	10/A	1.3/64	7/16	7/16	7/64	.375	.375
1/4	10/B	1.7/32	1/2	1/2	9/64	.445	.445
5/16	10/C	1.25/64	37/64	37/64	11/64	.600	.525
3/8	10/D	1.25/64	37/64	37/64	11/64	.600	.525
1/2	L 10/F	1.19/32	21/32	21/32	15/64	.820	.710
1/2	M 10/F	1.49/64	45/64	45/64	19/64	.920	.920
5/8	L 10/H	1.57/64	49/64	49/64	19/64	.920	.920
5/8	M 10/H	1.27/32	3/4	3/4	15/64	1.100	.920
3/4	M 10/J	1.31/32	25/32	25/32	15/64	1.200	1.100

METRIC		FOR CAPTIVE SEALS – Prefix Pt. No. L FOR METAL COMP. – Prefix Pt. No. M					
TUBE O/D.	PART NUMBER	A	B	C	D	A/F1	A/F2
4	10/004	25.3	11	11	3.7	9	8
5	10/005	25.7	11.2	11.2	3.7	10	9
6	10/006	26.6	11.4	11.4	4.2	11	10
8	10/008	31.7	13.6	13.6	4.9	14	12
10	10/010	34.5	14.6	14.6	5.7	17	16
12	10/012	39.1	16.4	16.4	6.1	20	17

**BRASS TUBE FITTINGS**

IMPERIAL &amp; METRIC SIZES

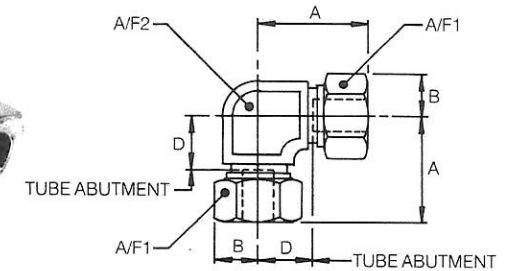
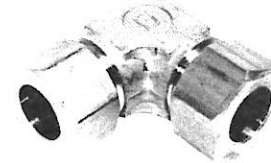
**Equal Elbow Coupling**

IMPERIAL		FOR CAPTIVE SEALS – Prefix Pt. No. L FOR METAL COMP. – Prefix Pt. No. M				
TUBE O/D.	PART NUMBER	A	B	D	A/F1	A/F2
1/8	20/R	21/32	7/32	3/16	.375	.375
3/16	20/A	21/32	7/32	3/16	.375	.375
1/4	20/B	25/32	17/64	15/64	.445	.468
5/16	20/C	57/64	11/32	9/32	.600	.562
3/8	20/D	57/64	11/32	9/32	.600	.562
1/2	L 20/F	1.1/4	15/32	9/16	.820	.820
1/2	M 20/F	1.1/4	17/32	9/16	.920	.820
5/8	L 20/H	1.23/64	17/32	9/16	.920	.820
5/8	M 20/H	1.23/64	41/64	9/16	1.100	.820
3/4	M 20/J	1.35/64	11/16	11/16	1.200	1.010

METRIC		FOR CAPTIVE SEALS – Prefix Pt. No. L FOR METAL COMP. – Prefix Pt. No. M				
TUBE O/D.	PART NUMBER	A	B	D	A/F1	A/F2
4	20/004	16.6	5.2	5.8	9	10
5	20/005	16.8	5.8	5.8	10	10
6	20/006	20	6.4	8.8	11	11
8	20/008	24.1	8.1	10.7	14	13
10	20/010	25.7	9.8	11.3	17	16
12	20/012	30.3	11.6	13.8	20	18

**BRASS TUBE FITTINGS**

IMPERIAL &amp; METRIC SIZES

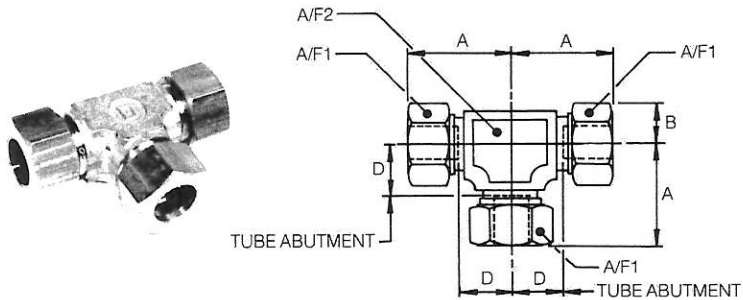
**Equal Tee Coupling**

IMPERIAL		FOR CAPTIVE SEALS – Prefix Pt. No. L FOR METAL COMP. – Prefix Pt. No. M				
TUBE O/D.	PART NUMBER	A	B	D	A/F1	A/F2
1/8	30/R	21/32	7/32	3/16	.375	.375
3/16	30/A	21/32	7/32	3/16	.375	.375
1/4	30/B	49/64	17/64	15/64	.445	.468
5/16	30/C	7/8	11/32	9/32	.600	.562
3/8	30/D	7/8	11/32	9/32	.600	.562
1/2	L 30/F	1.1/4	15/32	9/16	.820	.820
1/2	M 30/F	1.9/32	17/32	9/16	.920	.820
5/8	L 30/H	1.23/64	17/32	9/16	.920	.820
5/8	M 30/H	1.3/8	41/64	9/16	1.100	.820
3/4	M 30/J	1.35/64	11/16	11/16	1.200	1.010

METRIC		FOR CAPTIVE SEALS – Prefix Pt. No. L FOR METAL COMP. – Prefix Pt. No. M				
TUBE O/D.	PART NUMBER	A	B	D	A/F1	A/F2
4	30/004	16.6	5.2	5.8	9	10
5	30/005	16.8	5.8	5.8	10	10
6	30/006	20	6.4	8.8	11	11
8	30/008	24.1	8.1	10.7	14	13
10	30/010	25.7	9.8	11.3	17	16
12	30/012	30.3	11.6	13.8	20	18

**BRASS TUBE FITTINGS**

IMPERIAL &amp; METRIC SIZES

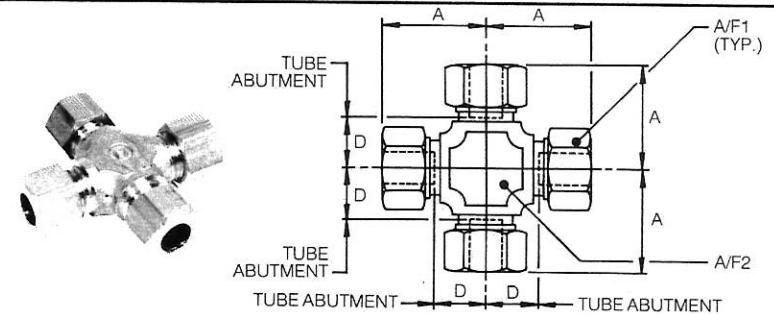
**Equal Cross Coupling**

IMPERIAL		FOR CAPTIVE SEALS – Prefix Pt. No. L FOR METAL COMP. – Prefix Pt. No. M			
TUBE O/D.	PART NUMBER	A	D	A/F1	A/F2
1/8	40/R	21/32	19/64	.375	.375
3/16	40/A	21/32	3/16	.375	.375
1/4	40/B	27/32	5/16	.445	.433
5/16	40/C	57/64	9/32	.600	.562
3/8	40/D	57/64	9/32	.600	.562

METRIC		FOR CAPTIVE SEALS – Prefix Pt. No. L FOR METAL COMP. – Prefix Pt. No. M			
TUBE O/D.	PART NUMBER	A	D	A/F1	A/F2
4	40/004	16.6	5.8	9	10
5	40/005	16.8	5.8	10	10
6	40/006	20	8.8	11	11
8	40/008	24.1	10.7	14	13
10	40/010	25.7	11.3	17	16
12	40/012	30.3	13.8	20	18

**BRASS TUBE FITTINGS**

IMPERIAL &amp; METRIC SIZES

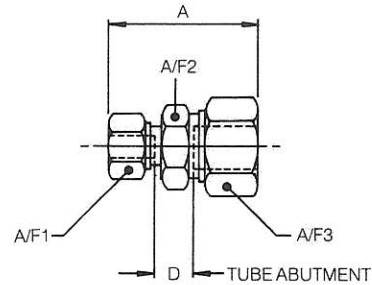
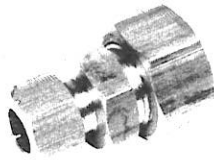
**Reducing Coupling**

IMPERIAL		FOR CAPTIVE SEALS – Prefix Pt. No. L FOR METAL COMP. – Prefix Pt. No. M				
TUBE O/D.	PART NUMBER	A	D	A/F1	A/F2	A/F3
1/8-5/64	L50/R/08	1.7/64	11/64	.375	.375	.375
3/16-1/8	50/A/R	1.3/64	7/64	.375	.375	.375
1/4-5/64	L50/B/08	1.5/32	9/64	.375	.445	.445
1/4-1/8	50/B/R	1.5/32	9/64	.375	.445	.445
1/4-3/16	50/B/A	1.5/32	9/64	.375	.445	.445
5/16-3/16	50/C/A	1.7/32	9/64	.375	.525	.600
5/16-1/4	50/C/B	1.5/16	11/64	.445	.525	.600
3/8-1/8	50/D/R	1.1/4	11/64	.375	.525	.600
3/8-3/16	50/D/A	1.7/32	9/64	.375	.525	.600
3/8-1/4	50/D/B	1.5/16	11/64	.445	.525	.600
3/8-5/16	50/D/C	1.25/64	11/64	.600	.525	.600
1/2-1/4	L 50/F/B	1.1/2	19/64	.445	.710	.820
1/2-1/4	M 50/F/B	1.1/2	19/64	.445	.920	.920
1/2-5/16	L 50/F/C	1.9/16	17/64	.600	.710	.820
1/2-3/8	L 50/F/D	1.37/64	19/64	.600	.710	.820
5/8-3/8	L 50/H/D	1.11/16	19/64	.600	.920	.920

METRIC		FOR CAPTIVE SEALS – Prefix Pt. No. L FOR METAL COMP. – Prefix Pt. No. M				
TUBE O/D.	PART NUMBER	A	D	A/F1	A/F2	A/F3
4-6	50/004/006	26.2	4.2	9	10	11
5-8	50/005/008	29.3	4.9	10	12	14
6-8	50/006/008	29.5	4.9	11	12	14
6-10	50/006/010	31.3	5.7	11	16	17
8-12	50/008/012	36.3	6.4	14	17	20

**BRASS TUBE FITTINGS**

IMPERIAL &amp; METRIC SIZES

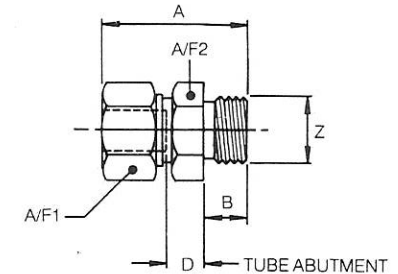
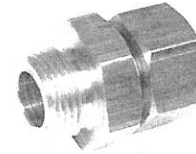
**Stud Parallel Male Coupling B.S.P.**

IMPERIAL		FOR CAPTIVE SEALS – Prefix Pt. No. L FOR METAL COMP. – Prefix Pt. No. M					
TUBE O/D.	PART NUMBER	A	B	D	Z B.S.P.	A/F1	A/F2
1/8	60/R/1	31/32	5/16	3/16	1/8	.375	.600
1/8	60/R/2	1.3/32	3/8	1/4	1/4	.375	.710
3/16	60/A/1	31/32	5/16	3/16	1/8	.375	.600
3/16	60/A/2	1.3/32	3/8	1/4	1/4	.375	.710
3/16	60/A/3	1.7/32	7/16	5/16	3/8	.375	.920
1/4	60/B/1	1.1/32	5/16	3/16	1/8	.445	.600
1/4	60/B/2	1.5/32	3/8	1/4	1/4	.445	.710
1/4	60/B/3	1.9/32	7/16	5/16	3/8	.445	.920
1/4	60/B/4	1.11/32	7/16	3/8	1/2	.445	1.100
5/16	60/C/1	1.3/32	5/16	3/16	1/8	.600	.600
5/16	60/C/2	1.15/64	3/8	1/4	1/4	.600	.710
5/16	60/C/3	1.23/64	7/16	5/16	3/8	.600	.920
5/16	60/C/4	1.27/64	7/16	3/8	1/2	.600	1.100
3/8	60/D/1	1.7/64	5/16	3/16	1/8	.600	.600
3/8	60/D/2	1.15/64	3/8	1/4	1/4	.600	.710
3/8	60/D/3	1.23/64	7/16	5/16	3/8	.600	.920
3/8	60/D/4	1.27/64	7/16	3/8	1/2	.600	1.100
1/2	L 60/F/2	1.5/16	3/8	1/4	1/4	.820	.710
1/2	M 60/F/2	1.25/64	3/8	21/64	1/4	.920	.920
1/2	L 60/F/3	1.7/16	7/16	5/16	3/8	.820	.920
1/2	L 60/F/4	1.1/2	7/16	3/8	1/2	.820	1.100
1/2	M 60/F/4	1.1/2	7/16	25/64	1/2	.920	1.100
5/8	L 60/H/2	1.31/64	3/8	5/16	1/4	.920	.920
5/8	L 60/H/3	1.35/64	7/16	5/16	3/8	.920	.920
5/8	L 60/H/4	1.35/64	7/16	5/16	1/2	.920	1.100

# BRASS TUBE FITTINGS

IMPERIAL & METRIC SIZES

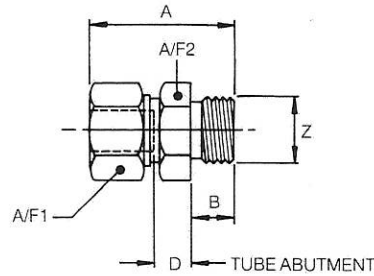
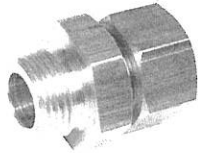

## Stud Parallel Male Coupling B.S.P.

METRIC		FOR CAPTIVE SEALS – Prefix Pt. No. L FOR METAL COMP. – Prefix Pt. No. M					
TUBE O/D.	PART NUMBER	A	B	D	Z B.S.P.	A/F1	A/F2
4	60/004/1	23.1	7.3	5.6	1/8	9	14
5	60/005/1	23.3	7.3	5.6	1/8	10	14
5	60/005/2	25.3	8.3	6.6	1/4	10	17
6	60/006/1	23.5	7.3	5.6	1/8	11	14
6	60/006/2	25.5	8.3	6.6	1/4	11	17
6	60/006/3	27.5	9.3	7.6	3/8	11	22
8	60/008/1	25.7	7.3	5.6	1/8	14	14
8	60/008/2	27.7	8.3	6.6	1/4	14	17
8	60/008/3	29.7	9.3	7.6	3/8	14	22
10	60/010/2	28.7	8.3	6.6	1/4	17	17
10	60/010/3	30.7	9.3	7.6	3/8	17	22
10	60/010/4	33.7	11.3	8.6	1/2	17	27
12	60/012/2	30.5	8.3	6.3	1/4	20	17
12	60/012/3	32.5	9.3	7.3	3/8	20	22
12	60/012/4	35.5	11.3	8.3	1/2	20	27
4	60/004/M5	23.1	7.3	5.6	M5 x 0.8	9	9
5	60/005/M5	23.3	7.3	5.6	M5 x 0.8	10	10
6	60/006/M5	23.5	7.3	5.6	M5 x 0.8	11	10

# BRASS TUBE FITTINGS

IMPERIAL & METRIC SIZES

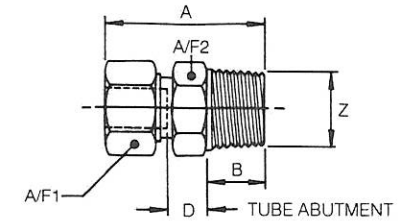
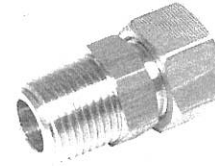

## Stud Taper Male B.S.P.T.

IMPERIAL		FOR CAPTIVE SEALS – Prefix Pt. No. L FOR METAL COMP. – Prefix Pt. No. M					
TUBE O/D.	PART NUMBER	A	B	D	Z B.S.P.T.	A/F1	A/F2
1/8	70/R/9	1"	3/8	5/32	1/8	.375	.445
1/8	70/R/11	1.3/16	17/32	3/16	1/4	.375	.600
3/16	70/A/9	1"	3/8	5/32	1/8	.375	.445
3/16	70/A/11	1.3/16	17/32	3/16	1/4	.375	.600
1/4	70/B/9	1.1/16	3/8	5/32	1/8	.445	.445
1/4	70/B/11	1.1/4	17/32	3/16	1/4	.445	.600
1/4	70/B/12	1.5/16	17/32	1/4	3/8	.445	.710
5/16	70/C/9	1.11/64	3/8	3/16	1/8	.600	.525
5/16	70/C/11	1.21/64	17/32	3/16	1/4	.600	.600
3/8	70/D/9	1.11/64	3/8	3/16	1/8	.600	.525
3/8	70/D/11	1.21/64	17/32	3/16	1/4	.600	.600
3/8	70/D/12	1.25/64	17/32	1/4	3/8	.600	.710
3/8	70/D/13	1.39/64	11/16	5/16	1/2	.600	.920
1/2	L 70/F/11	1.15/32	17/32	1/4	1/4	.820	.710
1/2	M 70/F/11	1.35/64	17/32	5/16	1/4	.920	.920
1/2	L 70/F/12	1.17/32	17/32	5/16	3/8	.820	.710
1/2	M 70/F/12	1.35/64	17/32	5/16	3/8	.920	.920
1/2	L 70/F/13	1.11/16	11/16	5/16	1/2	.820	.920
1/2	M 70/F/13	1.45/64	11/16	5/16	1/2	.920	.920

METRIC		FOR CAPTIVE SEALS – Prefix Pt. No. L FOR METAL COMP. – Prefix Pt. No. M					
TUBE O/D.	PART NUMBER	A	B	D	Z B.S.P.T.	A/F1	A/F2
4	70/004/9	26.1	10.3	5.6	1/8	9	12
5	70/005/9	26.3	10.3	5.6	1/8	10	12
5	70/005/11	31.6	14.6	6.6	1/4	10	16
6	70/006/9	26.5	10.3	5.6	1/8	11	12
6	70/006/11	31.8	14.6	6.6	1/4	11	16
6	70/006/12	32.8	14.6	7.6	3/8	11	18
8	70/008/9	28.7	10.3	5.6	1/8	14	12
8	70/008/11	34	14.6	6.6	1/4	14	16
8	70/008/12	35	14.6	7.6	3/8	14	18
10	70/010/11	35	14.6	6.6	1/4	17	16
10	70/010/12	36	14.6	7.6	3/8	17	18
10	70/010/13	37.7	15.3	8.3	1/2	17	22
12	70/012/11	36.8	14.6	6.3	1/4	20	17
12	70/012/12	37.8	14.6	7.3	3/8	20	18
12	70/012/13	39.5	15.3	8.3	1/2	20	22

# BRASS TUBE FITTINGS

IMPERIAL & METRIC SIZES

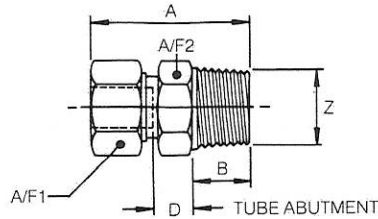
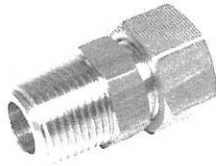

## Stud Taper Male N.P.T.

IMPERIAL		FOR CAPTIVE SEALS – Prefix Pt. No. L FOR METAL COMP. – Prefix Pt. No. M					
TUBE O/D.	PART NUMBER	A	B	D	Z N.P.T.	A/F1	A/F2
1/8	70/R/6	1.1/4	19/32	3/16	1/4	.375	.600
3/16	70/A/5	1.1/64	13/32	5/32	1/8	.375	.445
3/16	70/A/6	1.1/4	19/32	3/16	1/4	.375	.600
1/4	70/B/5	1.3/32	13/32	5/32	1/8	.445	.445
1/4	70/B/6	1.5/16	19/32	3/16	1/4	.445	.600
1/4	70/B/7	1.13/32	5/8	1/4	3/8	.445	.710
5/16	70/C/5	1.11/64	13/32	5/32	1/8	.600	.525
5/16	70/C/6	1.25/64	19/32	3/16	1/4	.600	.600
3/8	70/D/5	1.13/64	13/32	3/16	1/8	.600	.525
3/8	70/D/6	1.25/64	19/32	3/16	1/4	.600	.600
3/8	70/D/8	1.45/64	25/32	5/16	1/2	.600	.920
1/2	M 70/F/6	1.37/64	19/32	21/64	1/4	.920	.920
1/2	L 70/F/7	1.5/8	5/8	5/16	3/8	.820	.710

METRIC		FOR CAPTIVE SEALS – Prefix Pt. No. L FOR METAL COMP. – Prefix Pt. No. M					
TUBE O/D.	PART NUMBER	A	B	D	Z N.P.T.	A/F1	A/F2
4	70/004/5	26.1	10.3	5.6	1/8	9	11
5	70/005/5	26.3	10.3	5.6	1/8	10	11
6	70/006/5	26.5	10.3	5.6	1/8	11	11
6	70/006/6	31.8	14.6	6.6	1/4	11	16
8	70/008/6	34	14.6	6.6	1/4	14	16
10	70/010/6	35	14.6	6.6	1/4	17	16
10	70/010/7	36.2	14.8	7.6	3/8	17	18
12	70/012/6	36.8	14.6	6.3	1/4	20	17
12	70/012/7	38	14.8	7.3	3/8	20	18

# BRASS TUBE FITTINGS

IMPERIAL & METRIC SIZES

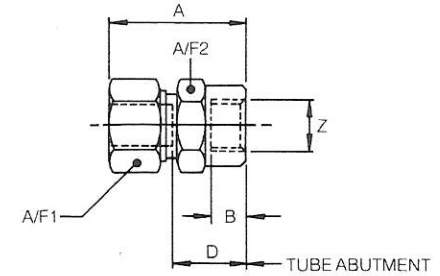
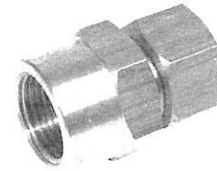

## Stud Parallel Female Coupling B.S.P.

IMPERIAL		FOR CAPTIVE SEALS – Prefix Pt. No. L FOR METAL COMP. – Prefix Pt. No. M					
TUBE O/D.	PART NUMBER	A	B	D	Z B.S.P.	A/F1	A/F2
1/8	80/R/1	1"	3/8	17/32	1/8	.375	.525
1/8	80/R/2	1.1/16	7/16	19/32	1/4	.375	.710
3/16	80/A/1	1"	3/8	17/32	1/8	.375	.525
3/16	80/A/2	1.1/16	7/16	19/32	1/4	.375	.710
3/16	80/A/3	1.7/64	1/2	41/64	3/8	.375	.820
1/4	80/B/1	1.1/32	3/8	1/2	1/8	.445	.525
1/4	80/B/2	1.3/32	7/16	9/16	1/4	.445	.710
1/4	80/B/3	1.5/32	1/2	5/8	3/8	.445	.820
1/4	80/B/4	1.11/32	5/8	13/16	1/2	.445	1.010
5/16	80/C/1	1.7/64	3/8	1/2	1/8	.600	.525
5/16	80/C/2	1.11/64	7/16	9/16	1/4	.600	.710
5/16	80/C/4	1.27/64	5/8	13/16	1/2	.600	1.010
3/8	80/D/1	1.7/64	3/8	1/2	1/8	.600	.525
3/8	80/D/2	1.11/64	7/16	9/16	1/4	.600	.710
3/8	80/D/3	1.17/64	1/2	21/32	3/8	.600	.820
3/8	80/D/4	1.27/64	5/8	13/16	1/2	.600	1.010
1/2	L 80/F/2	1.9/32	7/16	19/32	1/4	.820	.710
1/2	L 80/F/3	1.21/64	1/2	21/32	3/8	.820	.820
1/2	L 80/F/4	1.17/32	5/8	27/32	1/2	.820	1.010

METRIC		FOR CAPTIVE SEALS – Prefix Pt. No. L FOR METAL COMP. – Prefix Pt. No. M					
TUBE O/D.	PART NUMBER	A	B	D	Z B.S.P.	A/F1	A/F2
4	80/004/1	23.1	9.2	12.3	1/8	9	14
5	80/005/1	23.3	9.2	12.3	1/8	10	14
6	80/006/1	23.5	9.2	12.3	1/8	11	14
6	80/006/2	28.8	13.7	17.6	1/4	11	17
8	80/008/1	25.7	9.2	12.3	1/8	14	14
8	80/008/2	31	10.7	17.6	1/4	14	17
10	80/010/2	32	14	17.6	1/4	17	17
10	80/010/3	32.5	14	18.1	3/8	17	22
12	80/012/2	34.6	14	18.1	1/4	20	17
12	80/012/3	35.1	14	18.6	3/8	20	22

# BRASS TUBE FITTINGS

IMPERIAL & METRIC SIZES

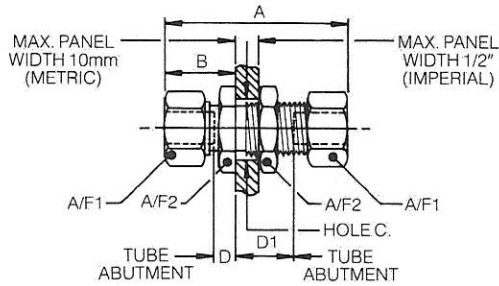
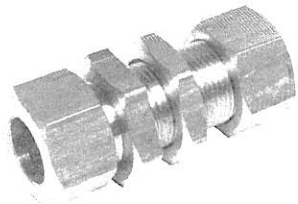

## Bulkhead Coupling

IMPERIAL		FOR CAPTIVE SEALS – Prefix Pt. No. L FOR METAL COMP. – Prefix Pt. No. M						
TUBE O/D.	PART NUMBER	A	B	C	D	D 1	A/F1	A/F2
1/8	90/R	1.49/64	5/8	11/32	5/32	11/16	.375	.525
3/16	90/A	1.49/64	5/8	11/32	5/32	11/16	.375	.525
1/4	90/B	1.7/8	11/16	13/32	5/32	21/32	.445	.600
5/16	90/C	2.9/64	55/64	17/32	1/4	11/16	.600	.710
3/8	90/D	2.9/64	55/64	17/32	1/4	11/16	.600	.710
1/2	L 90/F	2.19/32	1"	43/64	5/16	15/16	.820	.820
1/2	M90/F	2.23/32	1.1/16	55/64	5/16	15/16	.920	1.010
5/8	L 90/H	2.13/16	1.3/32	55/64	19/64	15/16	.920	1.010

METRIC		FOR CAPTIVE SEALS – Prefix Pt. No. L FOR METAL COMP. – Prefix Pt. No. M						
TUBE O/D.	PART NUMBER	A	B	C	D	D 1	A/F1	A/F2
4	90/004	40.8	15	8	4.7	15.3	9	11
5	90/005	41.2	15.2	9	4.7	15.3	10	12
6	90/006	41.6	15.4	10	4.7	15.3	11	14
8	90/008	46.5	18.1	12	5.2	15.3	14	16
10	90/010	49.3	19.6	15	5.7	15.6	17	20
12	90/012	53.4	21.4	17	5.4	15.8	20	22

# BRASS TUBE FITTINGS

IMPERIAL & METRIC SIZES

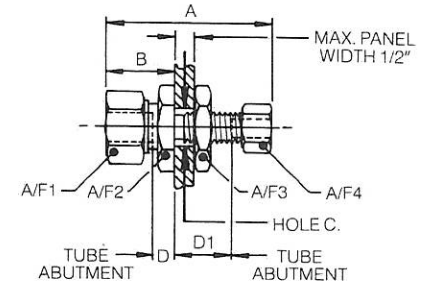
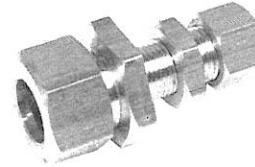

## Bulkhead Reducing Coupling

IMPERIAL		FOR CAPTIVE SEALS – Prefix Pt. No. L FOR METAL COMP. – Prefix Pt. No. M								
TUBE O/D.	PART NUMBER	A	B	C	D	D 1	A/F1	A/F2	A/F3	A/F4
1/4-1/8	90/B/R	1.27/32	11/16	11/32	5/32	11/16	.445	.525	.525	.375
1/4-3/16	90/B/A	1.27/32	11/16	11/32	5/32	11/16	.445	.525	.525	.375
3/8-1/4	90/D/B	1.31/32	51/64	13/32	3/16	21/32	.600	.600	.600	.445
1/2-1/4	L 90/F/B	2.7/64	59/64	13/32	1/4	21/32	.820	.710	.710	.445

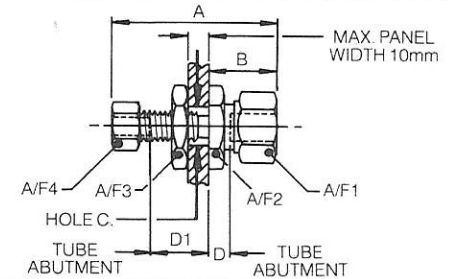
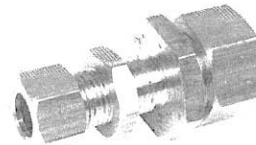

## Bulkhead Reducing Coupling

METRIC		FOR CAPTIVE SEALS – Prefix Pt. No. L FOR METAL COMP. – Prefix Pt. No. M								
TUBE O/D.	PART NUMBER	A	B	C	D	D 1	A/F1	A/F2	A/F3	A/F4
4-6	90/004/006	41.2	15.4	8	4.7	15.3	11	11	11	9
6-8	90/006/008	43.8	17.6	10	4.7	15.3	14	14	14	11
6-10	90/006/010	44.8	18.8	10	4.7	15.3	17	20	14	11
8-12	90/008/012	49.3	20.9	12	4.9	15.3	20	22	16	14



# BRASS TUBE FITTINGS

IMPERIAL & METRIC SIZES

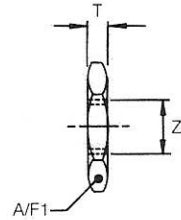

## Locknuts

IMPERIAL				
USED ON TUBE O/D.	PART NUMBER	Z	A/F1	T
1/8-3/16	95/05	5/16" x 26 T.P.I.	-525	1/8
1/4	95/1	1/8" B.S.P.	-600	3/16
5/16-3/8	95/2	1/4" B.S.P.	-710	3/16
L 90/F	95/3	3/8" B.S.P.	-820	5/16
M 90/F	95/4	1/2" B.S.P.	1-010	5/16

METRIC				
USED ON TUBE O/D.	PART NUMBER	Z	A/F1	T
4	95/M7	M7 x 1.0	11	4
5	95/M8	M8 x 1.0	12	4
6	95/M9	M9 x 1.0	14	4
8	95/M11	M11 x 1.0	16	4.5
10	95/M14	M14 x 1.0	20	5
12	95/M16	M16 x 1.0	22	5

# BRASS TUBE FITTINGS

IMPERIAL & METRIC SIZES

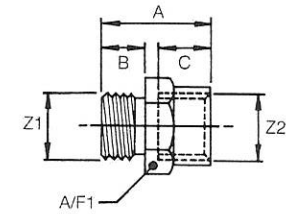

## Adaptor Male To Female B.S.P.

IMPERIAL						
Z1 B.S.P.	Z2 B.S.P.	PART NUMBER	A	B	C	A/F1
1/8	1/8	100/1/1	25/32	9/32	3/8	-525" (13.3)
1/8	1/4	100/1/2	27/32	9/32	7/16	-710" (18 )
1/8	3/8	100/1/3	29/32	9/32	15/32	-820" (20.8)
1/8	1/2	100/1/4	1.3/32	9/32	5/8	1-010" (25.7)
1/4	1/4	100/2/2	7/8	11/32	7/16	-710" (18 )
1/4	3/8	100/2/3	15/16	11/32	15/32	-820" (20.8)
1/4	1/2	100/2/4	1.1/8	11/32	19/32	1-010" (25.7)

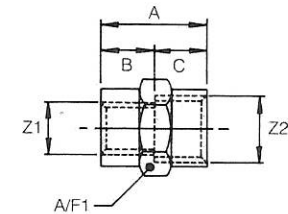

## Adaptor Female To Female

IMPERIAL						
Z1 B.S.P.	Z2 B.S.P.	PART NUMBER	A	B	C	A/F1
1/8	1/8	110/1/1	3/4	3/8	3/8	-525" (13.3)
1/8	1/4	110/1/2	13/16	3/8	7/16	-710" (18 )
1/4	1/4	110/2/2	7/8	7/16	7/16	-710" (18 )
1/4	3/8	110/2/3	15/16	7/16	1/2	-820" (20.8)
1/4	1/2	110/2/4	1.1/16	7/16	5/8	1-010" (25.7)

# BRASS TUBE FITTINGS

IMPERIAL & METRIC SIZES

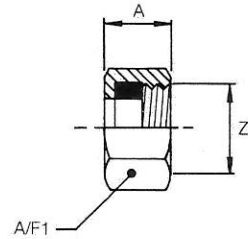

## Union Nut Captive Seal

IMPERIAL		CAPTIVE SEALS		
TUBE O/D.	PART NUMBER	Z	A	A/F1
5/64	L 120/08	5/16 x 26 T.P.I.	-315	-375
1/8	L 120/R	5/16 x 26 T.P.I.	-315	-375
3/16	L 120/A	5/16 x 26 T.P.I.	-315	-375
1/4	L 120/B	1/8 B.S.P.	-385	-445
5/16	L 120/C	1/4 B.S.P.	-445	-600
3/8	L 120/D	1/4 B.S.P.	-445	-600
1/2	L 120/F	3/8 B.S.P.	-505	-820
5/8	L 120/H	1/2 B.S.P.	-605	-920

METRIC		CAPTIVE SEALS		
TUBE O/D.	PART NUMBER	Z	A	A/F1
4	L 120/004	M7 x 1.0	7.9	9
5	L 120/005	M8 x 1.0	8.1	10
6	L 120/006	M9 x 1.0	8.3	11
8	L 120/008	M11 x 1.0	9.8	14
10	L 120/010	M14 x 1.0	10.8	17
12	L 120/012	M16 x 1.0	12.1	20

# BRASS TUBE FITTINGS

IMPERIAL & METRIC SIZES

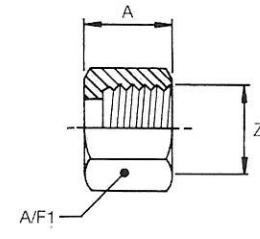
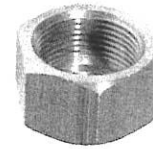

## Union Nut Metal Compression

IMPERIAL		METAL COMPRESSION		
TUBE O/D.	PART NUMBER	Z	A	A/F1
1/8	M 120/R	5/16 x 26 T.P.I.	-310	-375
3/16	M 120/A	5/16 x 26 T.P.I.	-310	-375
1/4	M 120/B	1/8 B.S.P.	-380	-445
5/16	M 120/C	1/4 B.S.P.	-437	-600
3/8	M 120/D	1/4 B.S.P.	-440	-600
1/2	M 120/F	1/2 B.S.P.	-530	-920
5/8	M 120/H	5/8 B.S.P.	-593	1-100
3/4	M 120/J	3/4 B.S.P.	-593	1-200

METRIC		METAL COMPRESSION		
TUBE O/D.	PART NUMBER	Z	A	A/F1
4	M 120/004/P	M7 x 1.0	7.9	9
5	M 120/005/P	M8 x 1.0	8.1	10
6	M 120/006/P	M9 x 1.0	8.3	11
8	M 120/008/P	M11 x 1.0	9.8	14
10	M 120/010/P	M14 x 1.0	10.8	17
12	M 120/012/P	M16 x 1.0	12.1	20

# BRASS TUBE FITTINGS

IMPERIAL & METRIC SIZES

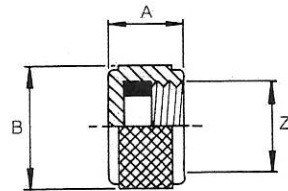

## Blanking Cap Knurled

IMPERIAL		CAPTIVE SEALS		
TUBE O/D.	PART NUMBER	Z	A	B DIA.
1/8	L 130/05	5/16 x 26 T.P.I.	310	7/16
3/16	L 130/05	5/16 x 26 T.P.I.	310	7/16
1/4	L 130/1	1/8 B.S.P.	380	9/16
5/16	L 130/2	1/4 B.S.P.	440	3/4
3/8	L 130/2	1/4 B.S.P.	440	3/4
1/2	L 130/3	3/8 B.S.P.	500	7/8
5/8	L 130/4	1/2 B.S.P.	600	1

METRIC		CAPTIVE SEALS		
TUBE O/D.	PART NUMBER	Z	A	B DIA.
4	L 130/004	M7 x 1.0	7.9	11.4
5	L 130/005	M8 x 1.0	8.1	12.4
6	L 130/006	M9 x 1.0	8.3	13.4
8	L 130/008	M11 x 1.0	9.8	16.4
10	L 130/010	M14 x 1.0	10.8	18.4
12	L 130/012	M16 x 1.0	12.1	20.4

# BRASS TUBE FITTINGS

IMPERIAL & METRIC SIZES

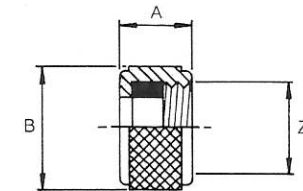

## Union Nut Knurled

IMPERIAL		CAPTIVE SEALS		
TUBE O/D.	PART NUMBER	Z	A	B DIA.
1/8	L 140/R	5/16 x 26 T.P.I.	310	7/16
3/16	L 140/A	5/16 x 26 T.P.I.	310	7/16
1/4	L 140/B	1/8 B.S.P.	380	9/16
5/16	L 140/C	1/4 B.S.P.	440	3/4
3/8	L 140/D	1/4 B.S.P.	440	3/4
1/2	L 140/F	3/8 B.S.P.	500	7/8
5/8	L 140/H	1/2 B.S.P.	600	1"

METRIC		CAPTIVE SEALS		
TUBE O/D.	PART NUMBER	Z	A	B DIA.
4	L 140/004	M7 x 1.0	7.9	11.4
5	L 140/005	M8 x 1.0	8.1	12.4
6	L 140/006	M9 x 1.0	8.3	13.4
8	L 140/008	M11 x 1.0	9.8	16.4
10	L 140/010	M14 x 1.0	10	18.4
12	L 140/012	M16 x 1.0	12.1	20.4

# BRASS TUBE FITTINGS

IMPERIAL & METRIC SIZES

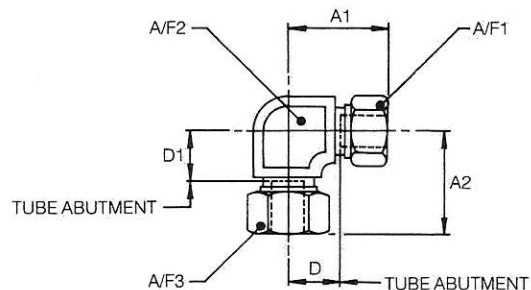
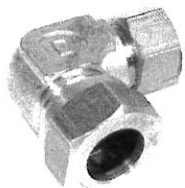

## Unequal Elbow Coupling

IMPERIAL		FOR CAPTIVE SEALS – Prefix Pt. No. L FOR METAL COMP. – Prefix Pt. No. M						
TUBE O/D.	PART NUMBER	A1	A2	D	D1	A/F1	A/F2	A/F3
3/16-1/8	150/A/R	21/32	21/32	3/16	3/16	.375	.375	.375
1/4-1/8	150/B/R	23/32	25/32	15/64	15/64	.375	.468	.445
1/4-3/16	150/B/A	23/32	25/32	15/64	15/64	.375	.468	.445

METRIC		FOR CAPTIVE SEALS – Prefix Pt. No. L FOR METAL COMP. – Prefix Pt. No. M						
TUBE O/D.	PART NUMBER	A1	A2	D	D1	A/F1	A/F2	A/F3

Product not yet available

# BRASS TUBE FITTINGS

IMPERIAL & METRIC SIZES

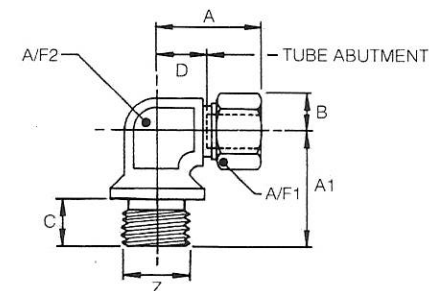

## Stud Elbow Parallel Male B.S.P.

IMPERIAL		FOR CAPTIVE SEALS – Prefix Pt. No. L FOR METAL COMP. – Prefix Pt. No. M							
TUBE O/D.	PART NUMBER	A	A1	B	C	D	Z B.S.P.	A/F1	A/F2
1/8	160/R/1	13/16	7/8	.216	5/16	11/32	1/8	.375	.525
3/16	160/A/1	13/16	7/8	.216	5/16	11/32	1/8	.375	.525
1/4	160/B/1	7/8	7/8	.257	5/16	11/32	1/8	.445	.525
1/4	160/B/2	7/8	15/16	.257	3/8	11/32	1/4	.445	.525
5/16	160/C/1	1.1/16	31/32	.346	5/16	29/64	1/8	.600	.600
5/16	160/C/2	1.1/16	1.1/32	.346	3/8	29/64	1/4	.600	.600
5/16	160/C/3	1.1/16	1.3/32	.346	7/16	29/64	3/8	.600	.600
3/8	160/D/1	1.1/16	31/32	.346	5/16	29/64	1/8	.600	.600
3/8	160/D/2	1.1/16	1/1.32	.346	3/8	29/64	1/4	.600	.600
3/8	160/D/3	1.1/16	1.3/32	.346	7/16	29/64	3/8	.600	.600

METRIC		FOR CAPTIVE SEALS – Prefix Pt. No. L FOR METAL COMP. – Prefix Pt. No. M							
TUBE O/D.	PART NUMBER	A	A1	B	C	D	Z B.S.P.	A/F1	A/F2
4	160/004/1	16.6	22.4	5.2	8.3	5.8	1/8	9	10
5	160/005/1	16.8	22.4	5.8	8.3	5.8	1/8	10	10
6	160/006/1	20	22.4	6.4	8.3	8.8	1/8	11	11
6	160/006/2	20	23.9	6.4	9.8	8.8	1/4	11	11
8	160/008/1	23.7	24.4	8.1	8.3	10.3	1/8	14	13
8	160/008/2	23.7	25.9	8.1	9.8	10.3	1/4	14	13
10	160/010/2	25.7	24.4	9.9	9.8	11.3	1/4	17	16
10	160/010/3	25.7	27.4	9.9	11.3	11.3	3/8	17	16
12	160/012/2	30.3	25.9	11.6	9.8	13.8	1/4	20	18
12	160/012/3	30.3	27.4	11.6	11.3	13.8	3/8	20	18
4	160/004/M5	16.6	20.9	5.2	7.3	5.8	M5x0.8	9	10

# BRASS TUBE FITTINGS

IMPERIAL & METRIC SIZES

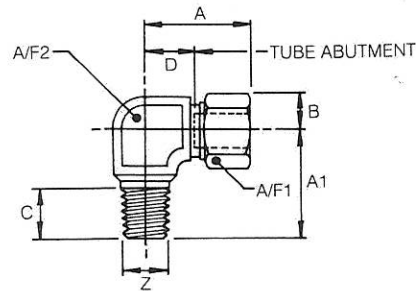
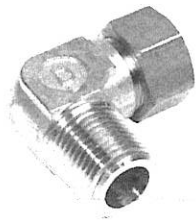

Stud Elbow Taper Male B.S.P.T.

IMPERIAL		FOR CAPTIVE SEALS – Prefix Pt. No. L FOR METAL COMP. – Prefix Pt. No. M							
TUBE O/D.	PART NUMBER	A	A1	B	C	D	Z B.S.P.T.	A/F1	A/F2
1/8	165/R/9	13/16	13/16	.216	3/8	11/32	1/8	.375	.525
3/16	165/A/9	13/16	13/16	.216	3/8	11/32	1/8	.375	.525
1/4	165/B/9	7/8	13/16	.257	3/8	11/32	1/8	.445	.525
1/4	165/B/11	7/8	31/32	.257	17/32	11/32	1/4	.445	.525
5/16	165/C/9	1.1/16	7/8	.346	3/8	29/64	1/8	.600	.600
5/16	165/C/11	1.1/16	1.1/16	.346	17/32	29/64	1/4	.600	.600
3/8	165/D/11	1.1/16	1.1/16	.346	17/32	29/64	1/4	.600	.600

METRIC		FOR CAPTIVE SEALS – Prefix Pt. No. L FOR METAL COMP. – Prefix Pt. No. M							
TUBE O/D.	PART NUMBER	A	A1	B	C	D	Z B.S.P.T.	A/F1	A/F2
4	165/004/9	16.6	20.9	5.2	9.5	5.8	1/8	9	10
5	165/005/9	16.6	20.9	5.8	9.5	5.8	1/8	10	10
6	165/006/9	20	20.9	6.4	9.5	8.8	1/8	11	11
6	165/006/11	20	24.9	6.4	13.5	8.8	1/4	11	11
8	165/008/9	24.1	20.9	8.1	9.5	10.7	1/8	14	13
8	165/008/11	24.1	27.4	8.1	13.5	10.7	1/4	14	13
10	165/010/11	25.7	27.4	9.9	12	11.3	1/4	17	16
10	165/010/12	25.7	27.4	9.9	13.5	11.3	3/8	17	16
12	165/012/11	30.3	27.4	11.6	13.4	13.8	1/4	20	18
12	165/012/12	30.3	27.4	11.6	13.5	13.8	3/8	20	18

# BRASS TUBE FITTINGS

IMPERIAL & METRIC SIZES

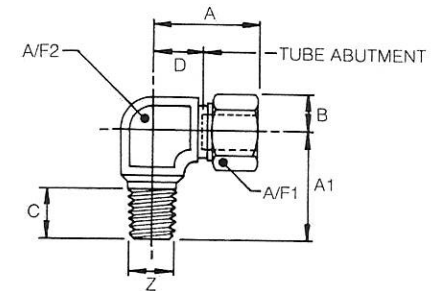
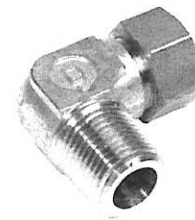

Stud Elbow Taper Male N.P.T.

IMPERIAL		FOR CAPTIVE SEALS – Prefix Pt. No. L FOR METAL COMP. – Prefix Pt. No. M							
TUBE O/D.	PART NUMBER	A	A1	B	C	D	Z N.P.T.	A/F1	A/F2
1/8	165/R/5	13/16	27/32	.216	13/32	11/32	1/8	.375	.525
3/16	165/A/5	13/16	27/32	.216	13/32	11/32	1/8	.375	.525
1/4	165/B/5	7/8	27/32	.257	13/32	11/32	1/8	.445	.525
1/4	165/B/6	7/8	1.1/32	.257	19/32	11/32	1/4	.445	.525
5/16	165/C/6	1.1/16	1.1/8	.346	19/32	29/64	1/4	.600	.600
3/8	165/D/6	1.1/16	1.1/8	.346	19/32	29/64	1/4	.600	.600

METRIC		FOR CAPTIVE SEALS – Prefix Pt. No. L FOR METAL COMP. – Prefix Pt. No. M							
TUBE O/D.	PART NUMBER	A	A1	B	C	D	Z N.P.T.	A/F1	A/F2
4	165/004/5	16.6	20.9	5.2	10	5.8	1/8	9	10
5	165/005/5	16.8	20.9	5.8	10	5.8	1/8	10	10
6	165/006/5	20	20.9	6.4	10	8.8	1/8	11	11
6	165/006/6	20	24.9	6.4	15	8.8	1/4	11	11
8	165/008/6	24.1	27.4	8.1	15	10.7	1/4	14	13
10	165/010/6	25.7	27.4	9.9	12	11.3	1/4	17	16
10	165/010/7	25.7	27.4	9.9	14.5	11.3	3/8	17	18
12	165/012/7	30.8	27.4	11.6	14.5	14.3	3/8	20	18
12	165/012/8	30.8	32.9	11.6	17	14.3	1/2	20	18

# BRASS TUBE FITTINGS

IMPERIAL & METRIC SIZES

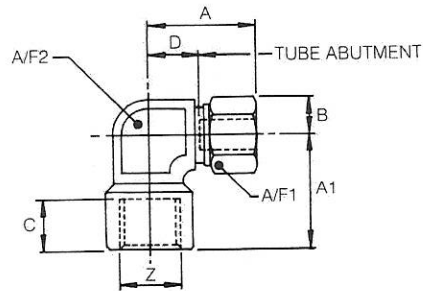

Stud Elbow Parallel Female B.S.P.

IMPERIAL		FOR CAPTIVE SEALS - Prefix Pt. No. L FOR METAL COMP. - Prefix Pt. No. M							
TUBE O/D.	PART NUMBER	A	A1	B	C	D	Z B.S.P.	A/F1	A/F2
1/8	170/R/1	13/16	25/32	.216	3/8	11/32	1/8	.375	.525
3/16	170/A/1	13/16	25/32	.216	3/8	11/32	1/8	.375	.525
1/4	170/B/1	7/8	29/32	.257	3/8	11/32	1/8	.445	.525
1/4	170/B/2	7/8	29/32	.257	7/16	11/32	1/4	.445	.525
1/4	170/B/3	31/32	1.1/8	.257	1/2	7/16	3/8	.445	.600
5/16	170/C/2	1.1/16	1.1/16	.346	7/16	29/64	1/4	.600	.600
3/8	170/D/3	1.1/16	1.1/8	.346	1/2	29/64	3/8	.600	.600

METRIC		FOR CAPTIVE SEALS - Prefix Pt. No. L FOR METAL COMP. - Prefix Pt. No. M							
TUBE O/D.	PART NUMBER	A	A1	B	C	D	Z B.S.P.	A/F1	A/F2

Product not yet available

# BRASS TUBE FITTINGS

IMPERIAL & METRIC SIZES

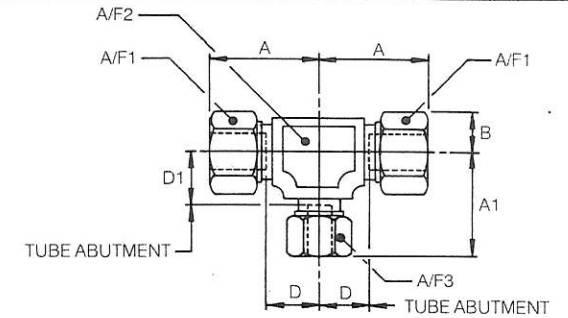
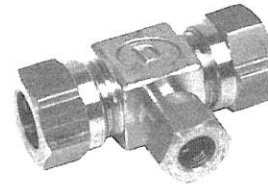

Unequal Tee

IMPERIAL		FOR CAPTIVE SEALS - Prefix Pt. No. L FOR METAL COMP. - Prefix Pt. No. M							
TUBE O/D.	PART NUMBER	A	A1	B	D	D1	A/F1	A/F2	A/F3
1/4-3/16	180/B/B/A	49/64	45/64	.257	7/32	15/64	445	.468	.375
5/16-1/4	180/C/C/B	7/8	13/16	.346	9/32	9/32	600	.562	.445
3/8-1/4	180/D/D/B	7/8	13/16	.346	17/64	9/32	600	.562	.445

METRIC		FOR CAPTIVE SEALS - Prefix Pt. No. L FOR METAL COMP. - Prefix Pt. No. M							
TUBE O/D.	PART NUMBER	A	A1	B	D	D1	A/F1	A/F2	A/F3

Product not yet available

# BRASS TUBE FITTINGS

IMPERIAL & METRIC SIZES



IMPERIAL	Brass Olive		
	TUBE O/D. T	PART NUMBER	A
	1/8	M 190/R	5/32
	3/16	M 190/A	5/32
	1/4	M 190/B	5/32
	5/16	M 190/C	3/16
	3/8	M 190/D	3/16

IMPERIAL	Copper Ferrule		
	TUBE O/D. T	PART NUMBER	A
	1/2	M 190/F	1/4
	5/8	M 190/H	9/32
	3/4	M 190/J	9/32
	---	---	---

METRIC	Brass Olive		
	TUBE O/D. T	PART NUMBER	A
	4	M 190/004/P	2.82
	5	M 190/005/P	3.82
	6	M 190/006/P	4.12
	8	M 190/008/P	4.12
	10	M 190/010/P	5.12
	12	M 190/012/P	5.62

# BRASS TUBE FITTINGS

IMPERIAL & METRIC SIZES

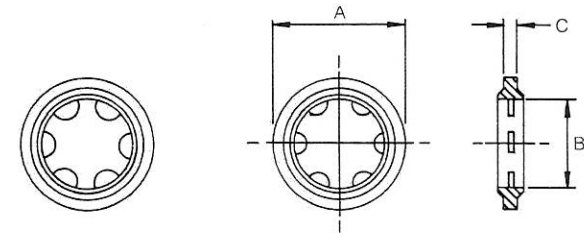

## Nylon Washer

IMPERIAL	FOR - Parallel male stud coupling fittings			
PART No.	STUD THREAD	A	B	C
200/1	1/8" B.S.P.	.630	.435	.065
200/2	1/4" B.S.P.	.815	.575	.065
200/3	3/8" B.S.P.	.942	.715	.065
200/4	1/2" B.S.P.	1.130	.895	.085
200/14	5/8" B.S.P.	1.255	.970	.085
200/15	3/4" B.S.P.	1.380	1.130	.085

NOTE: Unless otherwise instructed stud couplings are despatched fitted with nylon washer.

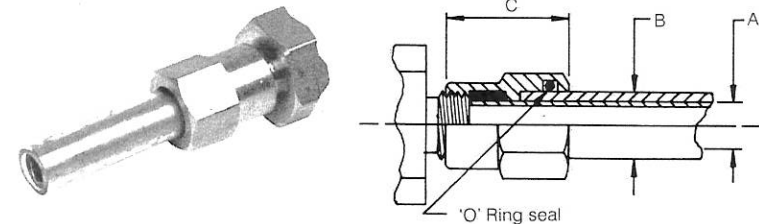

## Back Seal - Captive Seal Nut

IMPERIAL		FOR - Plastic covered copper or aluminium tubing			
TUBE O/D. A	TUBE O/D. B	PART No.	NUT THREAD	A/F	C
1/4	5/16	1C	1/8" B.S.P.	.525	11/16
3/8	7/16	1D	1/4" B.S.P.	.710	13/16
1/2	9/16	1F	3/8" B.S.P.	.820	1"

# BRASS TUBE FITTINGS

IMPERIAL & METRIC SIZES

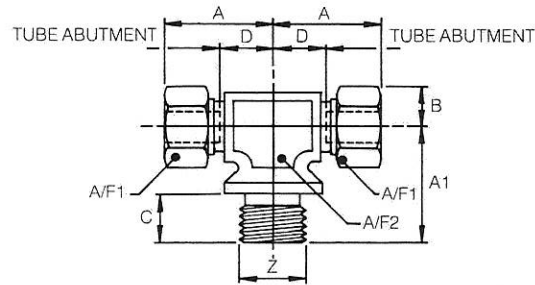
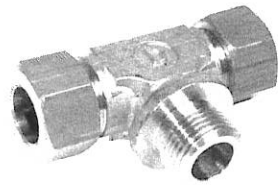

### Stud Tee Parallel Male B.S.P.

IMPERIAL		FOR CAPTIVE SEALS – Prefix Pt. No. L FOR METAL COMP. – Prefix Pt. No. M							
TUBE O/D.	PART NUMBER	A	A1	B	C	D	Z B.S.P.	A/F1	A/F2
3/16	210/A/A/1	13/16	27/32	216	5/16	11/32	1/8	375	525
1/4	210/B/B/1	7/8	27/32	257	5/16	11/32	1/8	445	525
1/4	210/B/B/2	7/8	29/32	257	3/8	11/32	1/4	445	525
5/16	210/C/C/2	1.1/16	1.1/32	346	3/8	29/64	1/4	600	600

METRIC		FOR CAPTIVE SEALS – Prefix Pt. No. L FOR METAL COMP. – Prefix Pt. No. M							
TUBE O/D.	PART NUMBER	A	A1	B	C	D	Z B.S.P.	A/F1	A/F2
4	210/004/004/1	16.6	22.4	5.2	8.3	5.8	1/8	9	10
5	210/005/005/1	16.8	22.4	5.8	8.3	5.8	1/8	10	10
6	210/006/006/1	20	22.4	6.4	8.3	8.8	1/8	11	11
6	210/006/006/2	20	23.9	6.4	9.8	8.8	1/4	11	11
8	210/008/008/2	24.1	25.9	8.1	9.8	10.7	1/4	14	13
10	210/010/010/2	25.7	25.7	9.9	9.8	11.3	1/4	17	16
10	210/010/010/3	27.9	27.4	9.9	11.3	13.5	3/8	17	18
12	210/012/012/2	30.3	25.9	11.6	9.8	13.8	1/4	20	18
12	210/012/012/3	30.3	27.4	11.6	11.3	13.8	3/8	20	18
4	210/004/004/M5	16.6	22.4	5.2	7.3	5.8	M5 x 0.8	9	10

# BRASS TUBE FITTINGS

IMPERIAL & METRIC SIZES

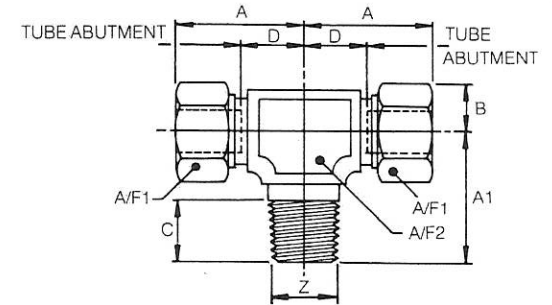
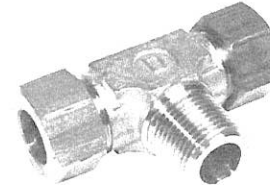

### Stud Tee Taper Male B.S.P.T.

IMPERIAL		FOR CAPTIVE SEALS – Prefix Pt. No. L FOR METAL COMP. – Prefix Pt. No. M							
TUBE O/D.	PART NUMBER	A	A1	B	C	D	Z B.S.P.T.	A/F1	A/F2
1/8	215/R/R/9	13/16	13/16	216	3/8	11/32	1/8	375	525
3/16	215/A/A/9	13/16	13/16	216	3/8	11/32	1/8	375	525
1/4	215/B/B/9	7/8	13/16	257	3/8	11/32	1/8	445	525
1/4	215/B/B/11	7/8	31/32	257	17/32	11/32	1/4	445	525
5/16	215/C/C/11	1.1/16	1.1/16	346	17/32	15/32	1/4	600	600

METRIC		FOR CAPTIVE SEALS – Prefix Pt. No. L FOR METAL COMP. – Prefix Pt. No. M							
TUBE O/D.	PART NUMBER	A	A1	B	C	D	Z B.S.P.T.	A/F1	A/F2
4	215/004/004/9	16.6	20.9	5.2	9.5	5.8	1/8	9	10
5	215/005/005/9	16.8	20.9	5.8	9.5	5.8	1/8	10	10
6	215/006/006/9	20	20.9	6.4	9.5	8.8	1/8	11	11
6	215/006/006/11	20	24.9	6.4	13.5	8.8	1/4	11	11
8	215/008/008/11	24.1	27.4	8.1	13.5	10.7	1/4	14	13
10	215/010/010/11	25.7	27.4	9.9	12	11.3	1/4	17	16
10	215/010/010/12	27.9	27.4	9.9	14.3	13.5	3/8	17	18
12	215/012/012/11	30.3	27.4	11.6	13.4	13.8	1/4	20	18
12	215/012/012/12	30.3	27.4	11.6	14.3	13.8	3/8	20	18



# BRASS TUBE FITTINGS

IMPERIAL & METRIC SIZES

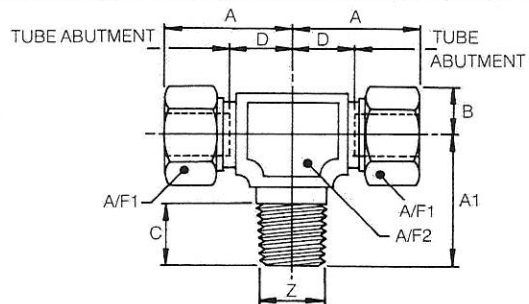
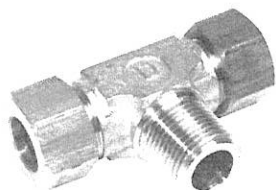

Stud Tee Taper Male N.P.T.

IMPERIAL		FOR CAPTIVE SEALS – Prefix Pt. No. L FOR METAL COMP. – Prefix Pt. No. M							
TUBE O/D.	PART NUMBER	A	A1	B	C	D	Z N.P.T.	A/F1	A/F2
3/16	215/A/A/5	13/16	27/32	.216	13/32	11/32	1/8	.375	.525
1/4	215/B/B/5	7/8	27/32	.257	13/32	11/32	1/8	.445	.525
1/4	215/B/B/6	7/8	1.1/32	.257	19/32	11/32	1/4	.445	.525
3/8	215/D/D/6	1.1/16	1.1/8	.346	19/32	15/32	1/4	.600	.600

METRIC		FOR CAPTIVE SEALS – Prefix Pt. No. L FOR METAL COMP. – Prefix Pt. No. M							
TUBE O/D.	PART NUMBER	A	A1	B	C	D	Z N.P.T.	A/F1	A/F2
5	215/005/005/5	16.8	20.9	5.8	10	5.8	1/8	10	10
6	215/006/006/5	20	20.9	6.4	10	8.8	1/8	11	11
6	215/006/006/6	20	24.9	6.4	15	8.8	1/4	11	11
8	215/008/008/6	24.1	27.4	8.1	15	10.7	1/4	14	13
10	215/010/010/6	25.7	27.4	9.9	12	11.3	1/4	17	16
10	215/010/010/7	25.7	27.4	9.9	14.3	11.3	3/8	17	18
12	215/012/012/6	30.8	27.4	11.6	15	14.3	1/4	20	18
12	215/012/012/7	30.8	27.4	11.6	14.3	14.3	3/8	20	18
12	215/012/012/8	30.8	27.4	11.6	14	14.3	1/2	20	18

# BRASS TUBE FITTINGS

IMPERIAL & METRIC SIZES

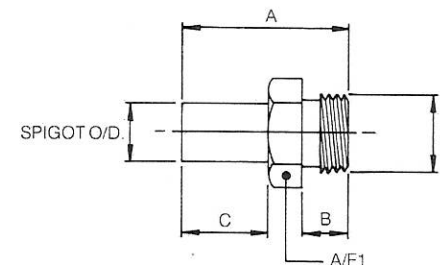
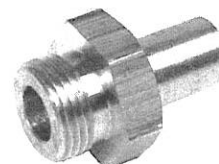

Spigot Adaptor Parallel Male B.S.P.

IMPERIAL						
SPIGOT O.D.	PART NUMBER	A	B	C	Z B.S.P.	A/F1
1/8	300/R/1	15/16	5/16	.437	1/8	.600
1/8	300/R/2	1"	3/8	.437	1/4	.710
3/16	300/A/1	15/16	5/16	.437	1/8	.600
3/16	300/A/2	1.1/16	3/8	.437	1/4	.710
1/4	300/B/1	1"	5/16	.487	1/8	.600
1/4	300/B/2	1.1/8	3/8	.487	1/4	.710
1/4	300/B/3	1.3/16	7/16	.487	3/8	.920
5/16	300/C/2	1.5/32	3/8	.530	1/4	.710
3/8	300/D/2	1.5/32	3/8	.530	1/4	.710
3/8	300/D/3	1.7/32	7/16	.530	3/8	.920
1/2	300/F/2	1.1/4	3/8	.593	1/4	.710
1/2	300/F/4	1.11/32	7/16	.593	1/2	1.100
5/8	300/H/4	1.1/2	7/16	.687	1/2	1.100

METRIC						
SPIGOT O.D.	PART NUMBER	A	B	C	Z B.S.P.	A/F1
4	300/004/1	19	7	7	1/8	14
5	300/005/1	20.5	7	8.5	1/8	14
6	300/006/1	21.5	7	9.5	1/8	14
6	300/006/2	23.5	8	9.5	1/4	17
8	300/008/2	26.5	8	12.5	1/4	17
10	300/010/2	28.5	8	14.5	1/4	17
10	300/010/3	30.5	9	14.5	3/8	22
12	300/012/3	32.5	9	16.5	3/8	22

# BRASS TUBE FITTINGS

IMPERIAL & METRIC SIZES

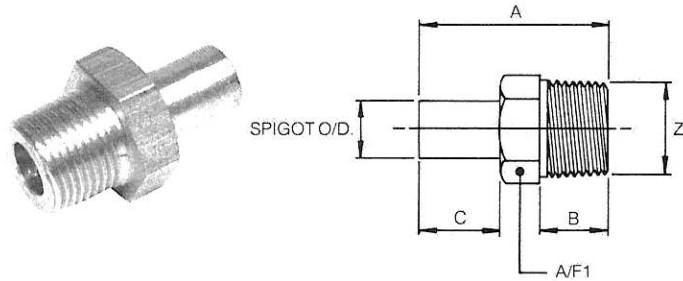

Spigot Adaptor Taper Male B.S.P.T.

IMPERIAL						
SPIGOT O.D.	PART NUMBER	A	B	C	Z B.S.P.T.	A/F1
3/16	310/A/11	1.1/8	17/32	-406	1/4	-600
1/4	310/B/9	1"	3/8	-487	1/8	-445
1/4	310/B/11	1.7/32	17/32	-487	1/4	-600
1/4	310/B/12	1.1/4	17/32	-487	3/8	-710
3/8	310/D/9	1.1/16	3/8	530	1/8	-445
3/8	310/D/11	1.1/4	17/32	-530	1/4	-600
3/8	310/D/12	1.5/16	17/32	-530	3/8	-710
1/2	310/F/11	1.5/16	17/32	-593	1/4	-600
1/2	310/F/12	1.3/8	17/32	-593	3/8	-710
1/2	310/F/13	1.19/32	11/16	-593	1/2	-920
3/4	310/J/13	1.13/16	11/16	812	1/2	-920

METRIC						
SPIGOT O.D.	PART NUMBER	A	B	C	Z B.S.P.T.	A/F1
4	310/004/9	22.4	10.3	7	1/8	12
5	310/005/9	23.9	10.3	8.5	1/8	12
6	310/006/9	24.9	10.3	9.5	1/8	12
6	310/006/11	30.2	14.6	9.5	1/4	16
8	310/008/11	33.2	14.6	12.5	1/4	16
10	310/010/11	35.2	14.6	14.5	1/4	16
12	301/012/12	37.4	14.3	16	3/8	22

# BRASS TUBE FITTINGS

IMPERIAL & METRIC SIZES

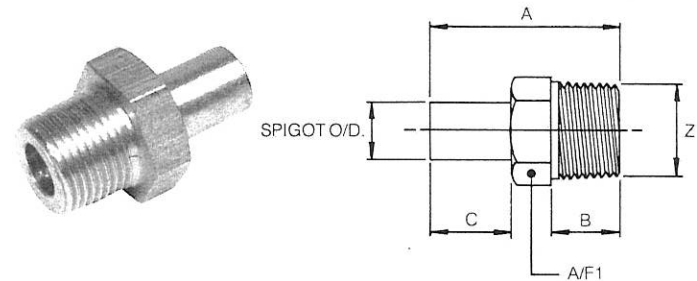

Spigot Adaptor Taper Male N.P.T.

IMPERIAL						
SPIGOT O.D.	PART NUMBER	A	B	C	Z N.P.T.	A/F1
3/16	310/A/5	31/32	13/32	-406	1/8	-445
3/16	310/A/6	1.3/16	19/32	-406	1/4	-600
1/4	310/B/5	1.1/16	13/32	-487	1/8	-445
1/4	310/B/6	1.1/4	19/32	-487	1/4	-600
3/8	310/D/5	1.3/32	13/32	-530	1/8	-445
3/8	310/D/6	1.5/16	17/32	-530	1/4	-600
3/8	310/D/7	1.13/32	5/8	-530	3/8	-710

METRIC						
SPIGOT O.D.	PART NUMBER	A	B	C	Z N.P.T.	A/F1

Product not yet available

# BRASS TUBE FITTINGS

IMPERIAL & METRIC SIZES

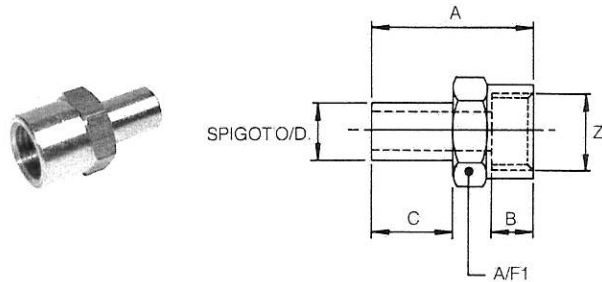

## Spigot Adaptor Parallel Female B.S.P.

IMPERIAL		FOR CAPTIVE SEALS – Prefix Pt. No. L FOR METAL COMP. – Prefix Pt. No. M				
SPIGOT O/D.	PART NUMBER	A	B	C	Z B.S.P.	A/F1
1/8	320/R/2	1.1/16	7/16	-406	1/4	-710
3/16	320/A/1	15/16	3/8	-406	1/8	-525
3/16	320/A/2	1"	7/16	-406	1/4	-710
3/16	320/A/5	15/16	3/8	-406	1/8 N.P.T.	-525
3/16	320/A/6	1.1/8	9/16	-406	1/4 N.P.T.	-710
1/4	320/B/1	1.1/64	3/8	-487	1/8	-525
1/4	320/B/2	1.3/64	7/16	-487	1/4	-710
1/4	320/B/3	1.5/32	1/2	-487	3/8	-820
5/16	320/C/2	1.3/32	7/16	-530	1/4	-710
3/8	320/D/2	1.1/8	7/16	-530	1/4	-710
3/8	320/D/4	1.11/32	5/8	-530	1/2	-1010
1/2	320/F/3	1.9/32	1/2	-593	3/8	-820

METRIC		FOR CAPTIVE SEALS – Prefix Pt. No. L FOR METAL COMP. – Prefix Pt. No. M				
SPIGOT O/D.	PART NUMBER	A	B	C	Z B.S.P.	A/F1
4	320/004/1	19.4	9.5	7	1/8	14
5	320/005/1	20.9	9.5	8.5	1/8	14
6	320/006/1	21.9	9.5	9.5	1/8	14
6	320/006/2	27.2	14.3	9.5	1/4	17
8	320/008/1	24.9	9.5	12.5	1/8	14
8	320/008/2	30.2	14.3	12.5	1/4	17
10	320/010/2	32.2	14.5	15	1/4	17

# BRASS TUBE FITTINGS

IMPERIAL & METRIC SIZES

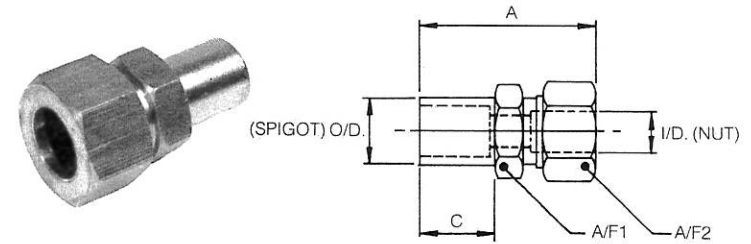

## Spigot Coupling Adaptor

IMPERIAL		FOR CAPTIVE SEALS – Prefix Pt. No. L FOR METAL COMP. – Prefix Pt. No. M				
O/D. (SPIGOT)	I/D. (NUT)	PART NUMBER	A	C	A/F1	A/F2
1/4	1/8	330/B/R	1.1/32	-478	-375	-375
1/4	3/16	330/B/A	1.1/32	-478	-375	-375
5/16	3/16	330/C/A	1.7/64	-530	-375	-375
5/16	1/4	330/C/B	1.13/64	-530	-445	-445
3/8	1/4	330/D/B	1.13/64	-530	-445	-445
1/2	1/4	330/F/B	1.5/16	-593	-525	-445
1/4	5/16	330/B/C	1.17/64	-478	-525	-600
1/2	5/16	330/F/C	1.3/8	-593	-525	-600
1/4	3/8	330/B/D	1.17/64	-478	-525	-600
1/4	1/2	L 330/B/F	1.27/64	-478	-710	-820
1/4	1/2	M 330/B/F	1.9/32	-478	-710	-820

METRIC		FOR CAPTIVE SEALS – Prefix Pt. No. L FOR METAL COMP. – Prefix Pt. No. M				
I/D. (NUT)	O/D. (SPIGOT)	PART NUMBER	A	C	A/F1	A/F2
4	1/8	330/004/R	24	10	8	9
4	3/16	330/004/A	24	10	8	9
5	3/16	330/005/A	25	10	9	10
6	1/4	330/006/B	27	12	10	11
8	5/16	330/008/C	31	14	12	14
10	3/8	330/010/D	33	14	16	17
12	1/2	330/012/F	37	15	17	20

**BRASS TUBE FITTINGS**

IMPERIAL &amp; METRIC SIZES

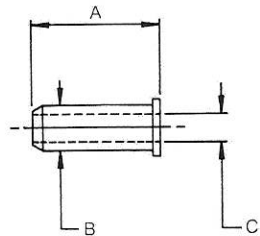

## Tube Insert

IMPERIAL		FOR SOFT WALL TUBING		
B	C	PART NUMBER	TUBE I/D.	A
.129	.082	340/A	1/8	.468
.156	.104	340/B	5/32	.530
.191	.141	340/C	3/16	.592
.254	.203	340/D	1/4	.592
.316	.265	340/E	5/16	.656
.377	.312	340/F	3/8	.656
.439	.375	340/H	7/16	.750

METRIC		FOR SOFT WALL TUBING		
B	C	PART NUMBER	TUBE I/D.	A
2.5	1.4	340/004	2.5	11.8
3.3	2.2	340/005	3.3	11.8
4.0	2.9	340/006	4.0	11.8
6.0	4.9	340/008	6.0	13.5

**BRASS TUBE FITTINGS**

IMPERIAL &amp; METRIC SIZES

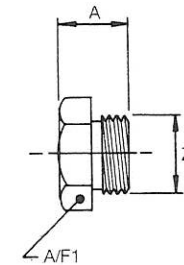

## Blanking Plug Parallel Male B.S.P.

IMPERIAL		_____	
PART NUMBER	A	Z B.S.P.	A/F1
360/1	1/2	1/8	.600
360/2	1/2	1/4	.710
360/3	3/4	3/8	.920
360/4	3/4	1/2	1.100

## Blanking Plug Taper Male N.P.T.

IMPERIAL		_____	
PART NUMBER	A	Z A.P.I.	A/F1
360/6	25/32	1/4	.600

## Blanking Plug Taper Male B.S.P.T.

IMPERIAL		_____	
PART NUMBER	A	Z B.S.P.T.	A/F1
360/9	17/32	1/8	.445

# BRASS TUBE FITTINGS

IMPERIAL & METRIC SIZES

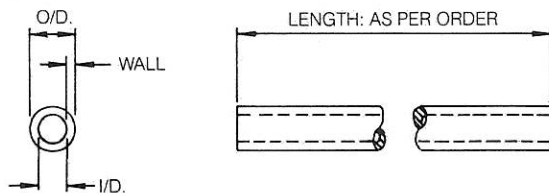

## Tubing

IMPERIAL				SEMI-RIGID NYLON			
TUBE O/D.	WALL Thickness	TUBE I/D.	Working Pressure	TUBE O/D.	WALL Thickness	TUBE I/D.	Working Pressure
1/8	Light	.095	435 P.S.I.	5/16	Medium	.212	610 P.S.I.
1/8	Heavy	.075	805	5/16	Heavy	.182	845
5/32	Light	.106	610	3/8	Light	.292	385
5/32	Heavy	.086	925	3/8	Medium	.250	640
3/16	Light	.137	500	3/8	Heavy	.225	805
3/16	Heavy	.107	875	1/2	Medium	.406	335
1/4	Light	.190	455	5/8	Medium	.500	335
1/4	Medium	.170	610	3/4	Medium	.594	370
1/4	Heavy	.150	805	1"	Medium	.813	325
5/16	Light	.242	405	---	---	---	---

METRIC				SEMI-RIGID NYLON			
TUBE O/D.	WALL Thickness	TUBE I/D.	Working Pressure	TUBE O/D.	WALL Thickness	TUBE I/D.	Working Pressure
4	1	2	70 BAR	8	1	6	30 BAR
5	1	3	52.5	10	1.25	7.5	30
6	1	4	42	12	1.5	9	30

IMPERIAL				LOW DENSITY POLYTHENE			
TUBE O/D.	WALL Thickness	TUBE I/D.	Working Pressure	TUBE O/D.	WALL Thickness	TUBE I/D.	Working Pressure
1/8	1/32	1/16	---	1/4	1/16	1/8	---
3/16	1/32	1/8	---	3/8	1/16	1/4	---
1/4	3/64	5/32	---	---	---	---	---

METRIC				LOW DENSITY POLYTHENE			
TUBE O/D.	WALL Thickness	TUBE I/D.	Working Pressure	TUBE O/D.	WALL Thickness	TUBE I/D.	Working Pressure
4	1	2	---	8	1	6	---
5	1	3	---	10	1	8	---
6	1	4	---	---	---	---	---

# BRASS TUBE FITTINGS

IMPERIAL & METRIC SIZES



## NYLON CHEMICAL RESISTANCE

ALCOHOLS	Concentration	Resistance		
		20°C	40°C	60°C
1 Methanol	pure	H*	M	L
2 Ethanol	pure	H*	M	L
3 Butanol		H*	M	L
4 Glycerine	pure	H	H	M
5 Glycol		H	H	M
6 Benzyl Alcohol		M*	L	L

## ALDEHYDES AND KETONES

	Concentration	Resistance		
		20°C	40°C	60°C
1 Acetone	pure	H*	M	M
2 Acetaldehyde		H*	M	L
3 Formaldehyde	technical	H*	M	L
4 Cyclohexanone		H*	M	L
5 Methylcyclohexanone		H*	H	M
6 Methylisobutylketone		H*	H	M
7 Benzaldehyde		H*	M	L

## PHENOLS

	Concentration	20°C	40°C	60°C
1 Phenol		L	L	L
2 Cresol		L	L	L
3 Resorcinol		L	L	L

## CHLORINATED SOLVENTS

	Concentration	20°C	40°C	60°C
1 Methyl Bromide		H*	L	L
2 Methyl Chloride		H*	L	L
3 Trichloroethylene		M*	L	L
4 Perchloroethylene		M*	L	L
5 Carbon Tetrachloride		L	L	L
6 Trichloroethane		L	L	L

## SALTS—ESTERS—ETHERS

	Concentration	20°C	40°C	60°C
1 Methyl Acetate		H*	H	H
2 Ethyl Acetate		H*	H	H
3 Butyl Acetate		H*	H	H
4 Amyl Acetate		H*	H	H
5 Tributyl Phosphate		H	H*	H
6 Tricresylphosphate		H	H*	H
7 Dioctylphosphate		H	H*	H
8 Diethylphthalate		H	H*	H
9 Diethyl Ether		H	H*	H
10 Fatty Acid Esters		H	H*	H
11 Methyl Sulphate		H	M	M

## VARIOUS ORGANIC COMPOUNDS

	Concentration	20°C	40°C	60°C
1 Anethole		L	L	L
2 Ethylene Chlorhydrin		H	H	M
3 Ethylene Oxide		H	H	M
4 Carbon Disulphide		H*	M	L
5 Furfuryl Alcohol		H	M	M
6 Lead Tetraethyl		H	M	M
7 Diaceton Alcohol		H*	M	M
8 Glucose		H	H	M

## VARIOUS PRODUCTS

	Concentration	20°C	40°C	60°C
1 Coal Gas		H	H	H
2 Oils		H	H	H
3 Greases		H	H	H
4 Beer		H	H	H
5 Wine		H	H	H
6 Fruit Juices		H	H	H
7 Normal Petrol		H	H	M
8 High Octane Petrol		H	H	M
9 Gas Oil		H	H	M
10 Solvent Naphtha		H*	H	M
11 Kerosene		H*	H	M
12 Crude Petroleum Oil		H*	H	M
13 Milk		H	H	M
14 Cider		H	H	M
15 Stearin		H	H	H
16 Mustard		H	H	H
17 Solutions or Emulsion of 2-4D		H	H	H
D.D.T. Preparation		H	H	H
Hydroxy Quinoline		H	H	H
18 Oil of Turpentine		H	H	M
19 Soap Solution		H	H	M
20 Vinegar		H	H	H
21 Linseed Cake		H	H	H

## DRALLIM PLASTIC TUBING

INORGANIC BASES	Concentration	Resistance		
		20°C	40°C	60°C
1 Sodium Hydroxide	50%	H	M	L
2 Potassium Hydroxide	50%	H	M	L
3 Ammonium Hydroxide	concentrated	H	H	H
4 Ammonia	liquid or gas	H	H	H

## INORGANIC ACIDS

	Concentration	20°C	40°C	60°C
1 Hydrochloric Acid	1%	H	M	L
	10%	H	M	L
2 Sulphuric Acid	1%	H	M	L
	10%	H	M	L
3 Phosphoric Acid	50%	H	M	L
4 Nitric Acid	all concentrations	L	L	L
5 Chromic Acid	10%	L	L	L
6 Sulphur Trioxide		M	L	L

## INORGANIC SALTS

	Concentration	20°C	40°C	60°C
1 Calcium Arsenate	concentrated solutions or pastes	H	H	H
2 Sodium Carbonate	"	H	H	M
3 Barium Chloride	"	H	H	H
4 Potassium Nitrate	"	H	M	L
5 Diammonium Phosphate	"	H	H	H
6 Trisodium Phosphate	"	H	H	H
7 Aluminium Sulphate	"	H	H	H
8 Ammonium Sulphate	"	H	H	M
9 Copper Sulphate	"	H	H	H
10 Potassium Sulphate	"	H	H	H
11 Sodium Sulphide	"	H	M	M
12 Calcium Chloride	"	H	H	H
13 Magnesium Chloride	50%	H	H	H
14 Sodium Chloride	saturated	H	H	H

## OTHER INORGANIC MATERIALS

	Concentration	20°C	40°C	60°C
1 Water		H	H	H
2 Sea Water		H	H	H
3 Soda Water		H	H	H
4 Hydrogen Peroxide	20 vol.	H	M	H
5 Oxygen		H	H	M
6 Hydrogen		H	H	H
7 Ozone		M	L	L
8 Sulphur		H	H	H
9 Mercury		H	H	H
10 Fluorine		L	L	L
11 Chlorine		L	L	L
12 Bromine		L	L	L
13 Potassium Permanganate	5%	L	L	L

## ORGANIC BASES

	Concentration	20°C	40°C	60°C
1 Aniline	pure	M	L	L
2 Pyridine	pure	M	L	L
3 Urea		H	H	M
4 Diethanolamine	20%	H	M	M

## ORGANIC ACIDS AND ANHYDRIDES

	Concentration	20°C	40°C	60°C
1 Acetic Acid		M	L	L
2 Acetic Anhydride		M	L	L
3 Citric Acid		H	H	M
4 Formic Acid		L	L	L
5 Lactic Acid		H	H	H
6 Oleic Acid		H	H	H
7 Oxalic Acid		H	H	M
8 Picric Acid		M	L	L
9 Stearic Acid		H	H	H
10 Tartaric Acid	saturated	H	H	H
11 Uric Acid		H	H	H

## HYDROCARBONS

	Concentration	20°C	40°C	60°C
1 Methane		H	H	H
2 Propane		H	H	H
3 Butane		H	H	H
4 Acetylene		H	H	H
5 Benzene		H*	M	M
6 Toluene		H*	M	M
7 Xylene		H*	M	M
8 Styrene		H*	M	M
9 Cyclohexane		H*	H	M
10 Naphthalene		H*	H	H
11 Decalin		H*	H	H
12 Freon 12		H	H	H
13 Freon 22		H	H	H

CHEMICAL RESISTANCE— H— High; M— Medium; L— Low.

# PLASTICS FITTINGS



## N-type couplings

The *EM-Teknik* range of polyamide (nylon) fittings with finger-gripping polypropylene union nuts has moulded-in tube inserts which allows the use of soft polyethylene tubing as well as harder materials. The couplings are also made entirely in polypropylene.

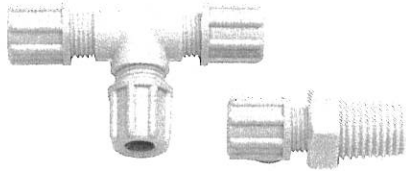

- equal union straight, bulkheads, elbows, tees and crosses
- unequal union straight and bulkheads
- stud straight, elbows and tees—run and branch
- female straight, elbows and branch tees

### Sizes

Inside/outside dia. tubing  
4/6 6/8 6/10 and 8/10mm  
Parallel G 1/4 G 1/2 G 3/4 and G 1/2 ISO and BSI  
Taper 1/4 1/2 3/4 and 1/2 in NPT (no ISO taper)

### Working limits

Pressure 10 bar; temperature -20 to +90°C

## P-type couplings

A limited range in acetal (delrin) based on the *Drallim* brass coupling design, and with the captive seal union nut.



- equal union straight, bulkheads, elbows and tees
- stud straight, parallel and taper

### Sizes

1/4 in/6 mm o/d tubing only. G 1/4 parallel stud, R 1/4 and R 1/4 taper.

### Working limits

Pressure 10 bar; temperature -20 to +80°C

## Hose-to-thread connectors

Male taper thread (ISO and NPT) to barbed spigot for hose or plastics tubing with or without worm-drive clips for added security with higher pressures. Straights, single and double elbows (tees) in polyamide (nylon).

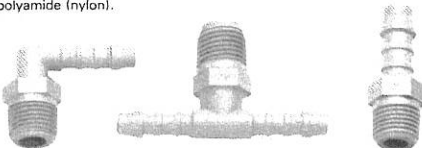

Sizes Hoses from 3 to 19mm inside diameter, threads R 1/4 to R 3/4 and 1/4" NPT to 1/2" NPT

## Hose-to-hose connectors

Similar to above but in acetal (delrin). Equal and unequal straight, tees and Y-pieces, plus equal elbows and crosses.

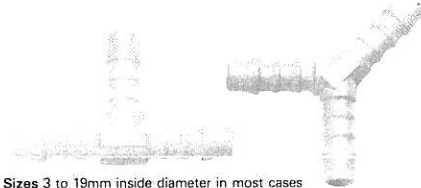

Sizes 3 to 19mm inside diameter in most cases

## Manifolds

Plan-a-line polyamide manifolds take all stud fittings listed herein and can be mounted on DIN rail using spring clips. Based on a moulded tee-form station, they incorporate two opposing G-threaded ports (1/4 or 1/2) leading to the central chamber, plus a third at right angles which is however not completely through to the centre. This is quickly drilled out if required. One-, two- and three-station modules allow manifolds of any length to be quickly assembled using an interconnecting G 1/4 nipple and seal.

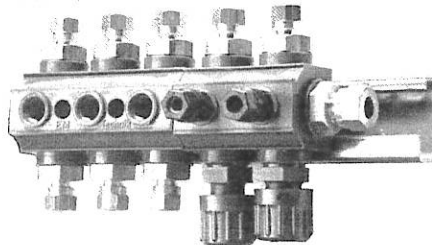

Series 8 polyamide or ptfe 30 x 40mm section blocks can be supplied with 5 or 10 ports on one 30mm face or 5 on each of two opposing faces. With closer pitched ports, 5, 10 or 15 ports can be supplied on one face and also 5 on opposite faces. Drillings are tapped for ISO R 1/2 taper connectors at each end and for R 1/4 at the ports.

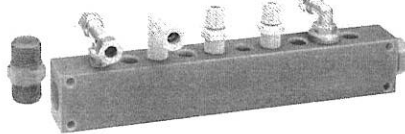

# MINIATURE VALVES



THE PRINCIPAL material is brass but 316 stainless steel is available to order in some cases. Standard union nuts have *Drallim* captive seals but metal compression couplings can also be supplied. Stud threads are given in the modern ISO form—G for parallel, R for taper—instead of the outdated BSP and BSPT: the actual threads of course are unchanged.

### Standard screwdown



Right-angled with internals for normal control (Type 1500) or metering by stainless steel needle (Type 4500). Panel mounting or taper stud for manifolds.

Sizes: 1/4 3/16 1/4 in and 4 5 6mm o/d tube, R 1/4 male taper stud. Pressure -1 to +10 bar.



### One-turn screwdown

Right-angled (Series 2300) or in-line (Series 2200), for panel or line mounting. Sizes: 2200 3-5mm bore for 3/16 1/4 in and 6mm o/d tube; Ser. 2300 5-0mm bore for 1/16 in and 8mm o/d tube. Pressure -1 to +10 bar.

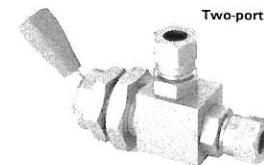

### Two-port toggle, standard

Interchangeable union-nut connectors screw into the valve body. Reversible toggles in various colours. Panel mounting (Ser. 2500) or manifold mounting (Ser. 2510) by R 1/4 taper stud on body. Sizes: 1/4 3/16 1/4 in, 5 and 6mm o/d tubing.

### Two-port toggle, special



Developed mainly for gas chromatography equipment but suitable for other instrumentation, the Series 2525 has totally different internals to the 2500 but is otherwise similar except it is not made in manifold mounting form.

### Clearflow control

The innovative design Series 511 has no seating in the ordinary sense, which ensures a completely unobstructed straight-through flow and at the same time a leaktight shutoff. Panel or line mounting. Sizes: 2mm bore for 1/4 in o/d tubing, 4mm for 1/2 in or 6mm.



### Pushbutton

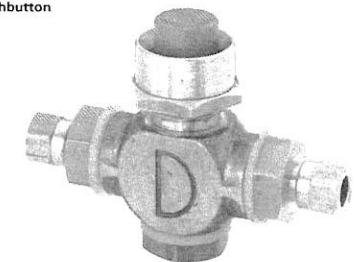

General purpose valves in three forms: Type 1010 straight-through, press-to-open; Type 1020 right-angled, press-to-close, and; Type 1030 three-port changeover, make-before-break. Bodies tapped G 1/4 (1/4 BSP) for any standard connector.