

Catalogo Generale 2011

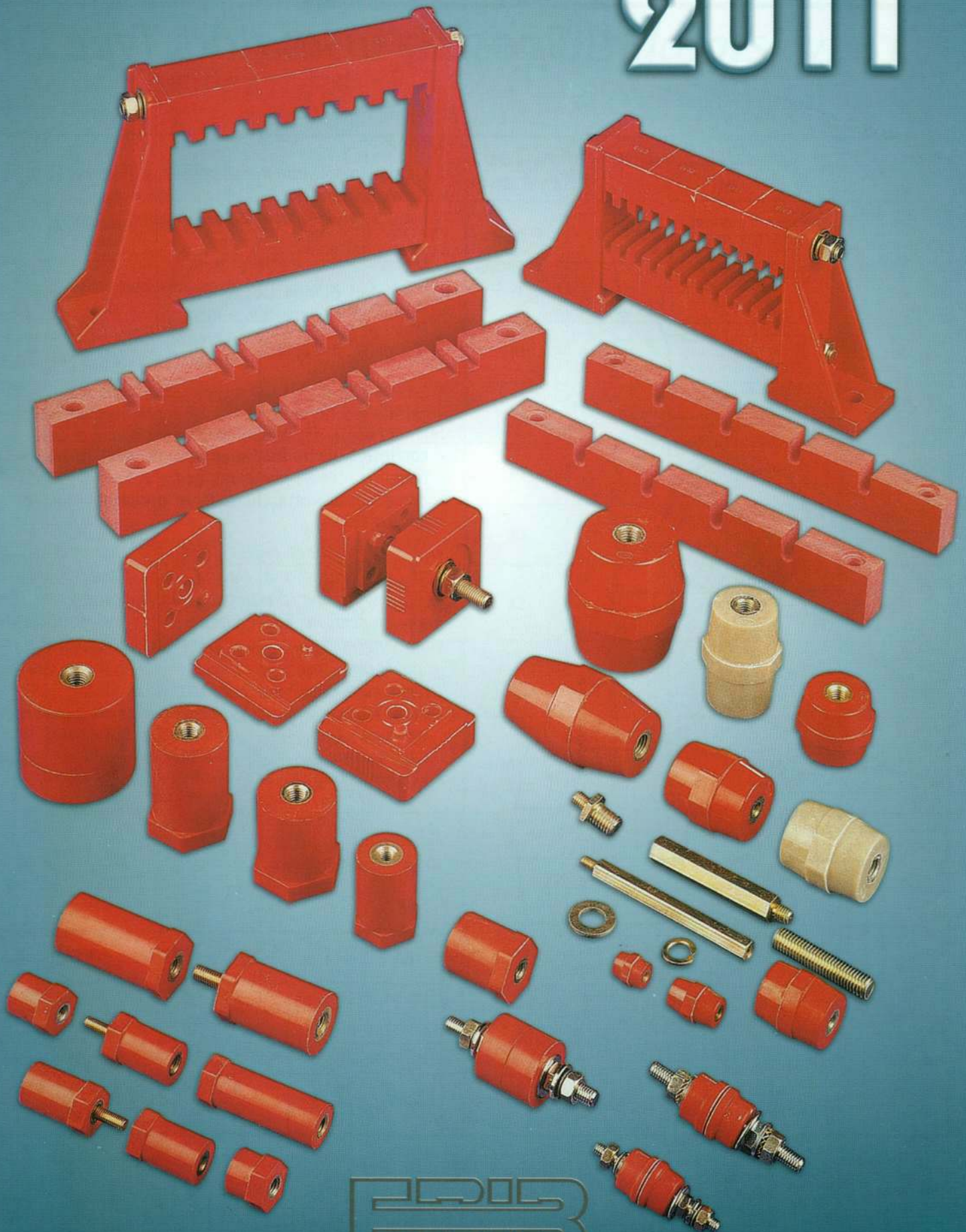

EDIL
STAMP

Isolatori Distanziatori Tipo DB

Spacing Insulators Type DB

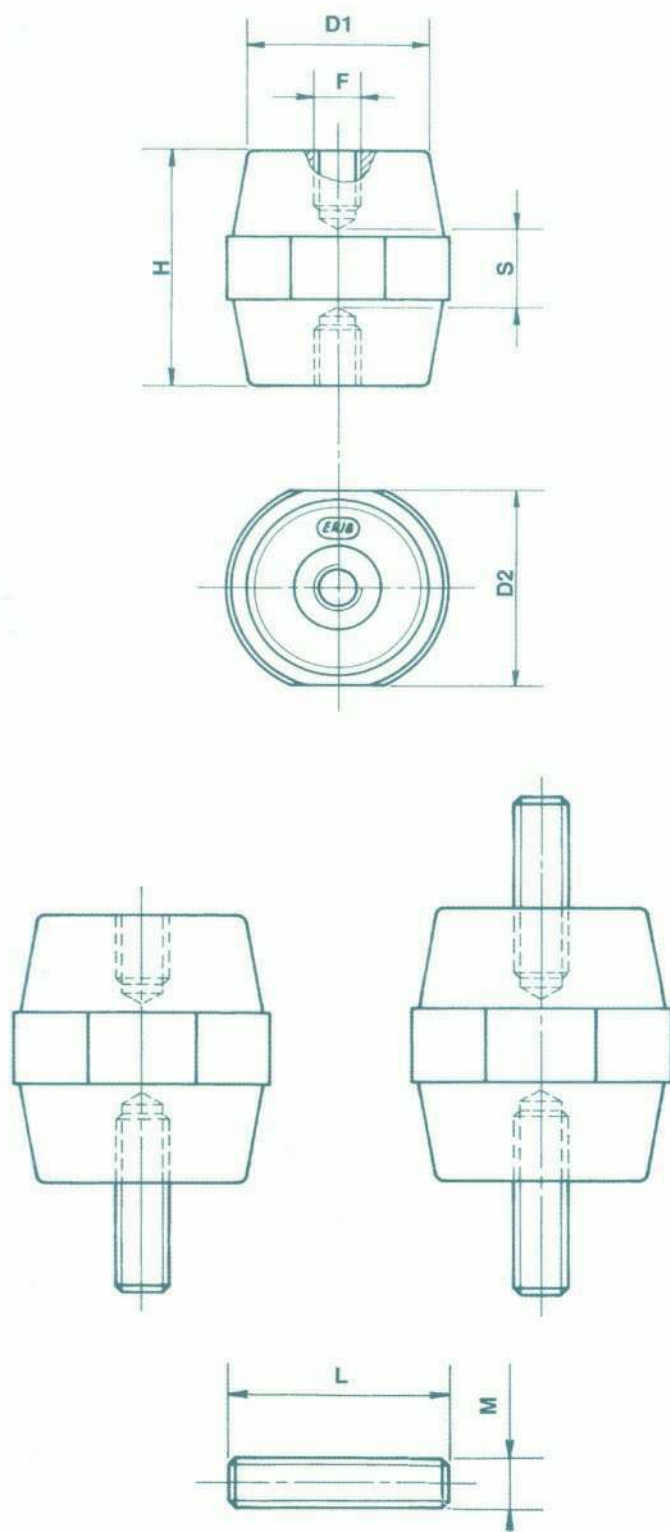

DB/P

Realizzati in polivetro massa poliestere, rinforzata con fibre di vetro, colore rosso.

Made in polyester material reinforced with fiberglass, red color.

Gli isolatori di tipo DB, assolutamente infrangibili, con caratteristiche elettriche e meccaniche elevate, possono essere impiegati anche in condizioni di esercizio precarie (elevate temperature ambientali, presenza di agenti corrosivi, vibrazioni, ecc.); la fascia centrale a facce contrapposte facilita la presa e il serraggio dell'isolatore. Su richiesta possiamo fornire gli isolatori:

- con inserti aventi filettatura diversa da quella prevista di serie
- con uno o due attacchi maschio "AM" montati e bloccati con loctite.

The DB insulators types, absolutely unbreakable, with high mechanical and electrical characteristics, can be used even under precarious working conditions (high room temperature, in the presence of corrosive substances, vibrations, etc.) the central layer sides ease the insulators gripping and locking of.

On request we can supply the spacing insulators:

- with inserts having a different thread from that foreseen for mass production
- with one or two male connections type "AM" set and locked with loctite.

AM

Attacchi maschi (perni tutto filetto)

Male connection (all thread screw)

M	L	M	L	M	L
4 x 16		6 x 25		10 x 30	
4 x 20		6 x 33		10 x 40	
5 x 20		8 x 33		10 x 50	
5 x 30		8 x 38		12 x 30	
6 x 20		8 x 50		12 x 50	

Isolatori Distanziatori Tipo DB

Spacing Insulators Type DB

		Caratteristiche Dimensionali <i>Size Characteristics</i>							
		Articolo <i>Article</i>	F	H mm	D1 mm	D2 mm	S mm	Tensione di esercizio <i>Operating voltage</i>	Conf. <i>Pack.</i>
●	●	DB 12/P	M 3 M 4	12	10	11	3	220 V	100
●	●	DB 16/P	M 3 M 4	16	13	14	6	380 V	100
●	●	DB 20/P	M 4 M 6	20	15	17	8	500 V	100
●	●	DB 25/P	M 5 M 6	25,2	15	19	9	600 V	250
●	●	DB 30/P	M 6 M 8	30	26	30	10	600 V	80
●		DB 34/P	M 6 M 8 M 10	35	28	32	10	1000 V	64
●		DB 35/P	M 6 M 8 M 10	35,5	35	41	10	1000 V	36
●		DB 45/P	M 6 M 8 M 10 M 12	45	35	41	15	1500 V	27
●		DB 50/P	M 6 M 8 M 10	51	29	36	20	2000 V	36
●		DB 65/P	M 6 M 8 M 10 M 12	63,5	35	41	30	3000 V	22
●		DB 75/P	M 8 M 10 M 12	76	36	50	25	5000 V	12
●		DB 750/P	M 10 M 12 M 16	75	52	65	25	5000 V	8

● ● Colori disponibili a magazzino o pronti

Isolatori Distanziatori Tipo DB

Spacing Insulators Type DB

• Sollecitazione a torsione • <i>Twisting stress</i>	DN x mm
• Sollecitazione a compressione • <i>Compressive stress</i>	DN
• Sollecitazione a flessione • <i>Cantilever stress</i>	DN
• Sollecitazione a trazione • <i>Tensile stress</i>	DN
• Tensione di scarica interna C.A. • <i>A.C. internal flashover voltage</i>	KV
• Tensione di scarica superficiale C.A. • <i>A.C. surface flashover voltage</i>	KV

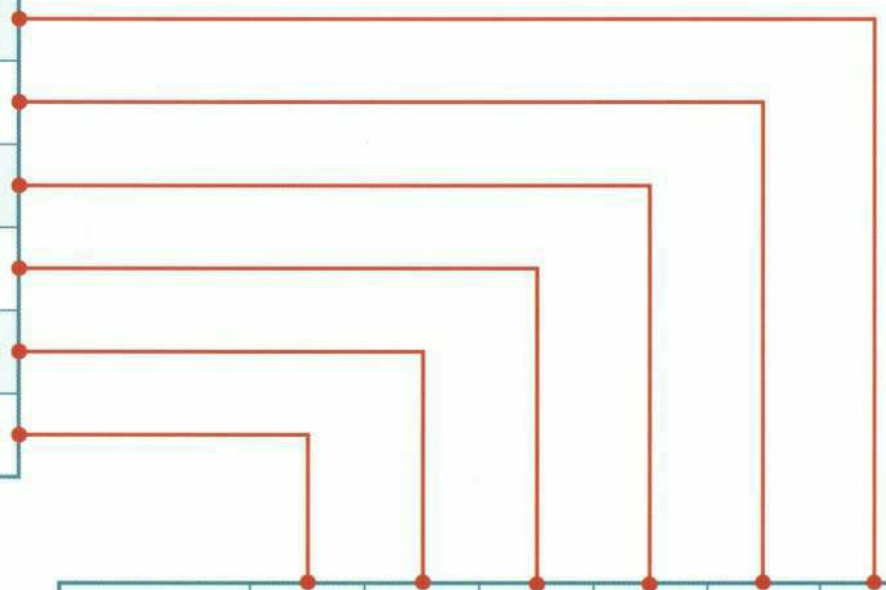

Temperatura di esercizio °C: -40° +130°
Operating temperature

Reazione al fuoco Classe: UL94-V0
Fire reaction Classe: UL94-V0

Carichi di rottura (tolleranza ± 10%)
Breaking charges (allowance ± 10%)

1DN = ~ 1Kg.

DB 12/P	-	-	-	-	-	-
DB 16/P	3	8	100	50	500	0,4
DB 20/P	4	15	150	60	600	0,4
DB 25/P	7	20	300	180	2.100	3
DB 30/P	8	23	500	250	4.400	3
DB 34/P	10	30	800	450	6.500	5
DB 35/P	10	30	1.100	800	8.000	9
DB 45/P	12	40	1.200	800	8.000	10
DB 50/P	12	40	850	450	6.800	6
DB 65/P	15	40	1.500	700	8.300	6
DB 75/P	25	50	2.300	900	10.000	10
DB 750/P	25	50	2.800	1.500	15.000	13

Colonnine Distanziatrici Tipo CO/P - Ø 20

Spacing Stud Bolts Type CO/P - Ø 20

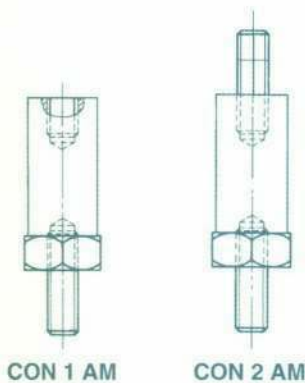
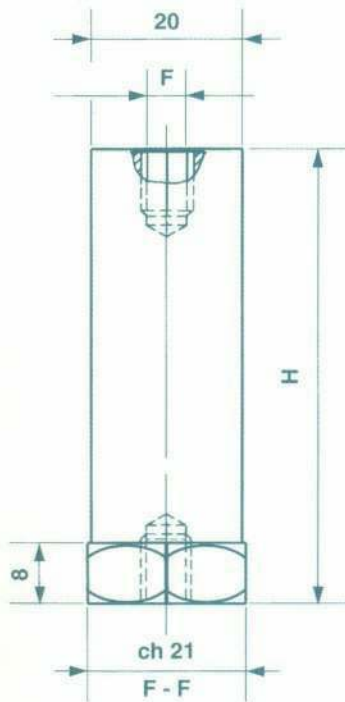

CO/P DIAMETRO 20

Realizzate in polivetro massa poliestere, rinforzata con fibre di vetro, colore rosso.

Made in polyester material reinforced with fiberglass, red color.

Articolo Article	F	H	Tensione di esercizio Operating voltage
CO/P 16	M 4 M 5 M 6	16 mm	220 V
CO/P 20	M 4 M 5 M 6 M 8	20 mm	400 V
CO/P 25	M 5 M 6 M 8	25 mm	500 V
CO/P 30	M 5 M 6 M 8	30 mm	600 V
CO/P 35	M 5 M 6 M 8	35 mm	600 V
CO/P 40	M 6 M 8	40 mm	600 V
CO/P 45	M 6 M 8	45 mm	750 V
CO/P 50	M 6 M 8	50 mm	750 V
CO/P 60	M 6 M 8	60 mm	750 V

Su richiesta possiamo fornire gli isolatori con uno o due attacchi maschi "AM" montati e bloccati con loctite.

On request we can supply the spacing insulators with one or two male connections type "AM" set and locked with loctite.

Colonnine Distanziatrici Tipo CS/P - Ø 30

Spacing Stud Bolts Type CS/P - Ø 30

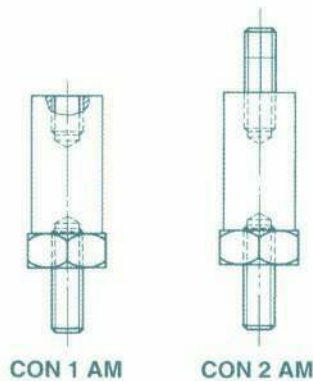
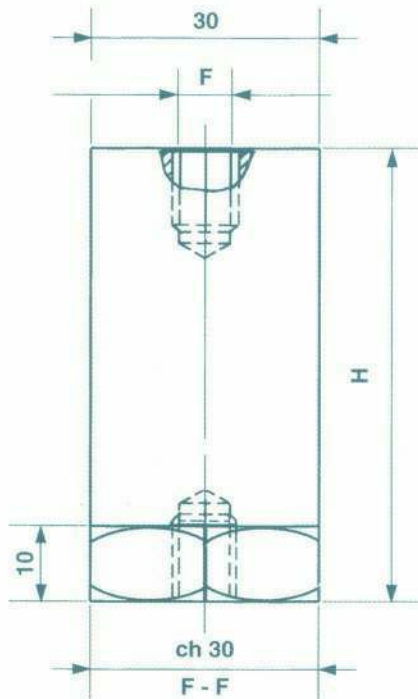

CS/P DIAMETRO 30

Realizzate in polivetro massa poliestere, rinforzata con fibre di vetro, colore rosso.

Made in polyester material reinforced with fiberglass, red color.

Articolo Article	F	H	Tensione di esercizio Operating voltage
CS/P 30	M 6 M 8 M 10	30 mm	750 V
CS/P 35	M 6 M 8 M 10	35 mm	1000 V
CS/P 40	M 6 M 8 M 10	40 mm	1000 V
CS/P 45	M 6 M 8 M 10	45 mm	1000 V
CS/P 50	M 6 M 8 M 10	50 mm	1500 V
CS/P 55	M 6 M 8 M 10	55 mm	1500 V
CS/P 60	M 6 M 8 M 10	60 mm	1500 V
CS/P 65	M 6 M 8 M 10	65 mm	1500 V
CS/P 70	M 6 M 8 M 10	70 mm	1500 V

Colonnine Distanziatrici Tipo CT/P - Ø 40

Spacing Stud Bolts Type CT/P - Ø 40

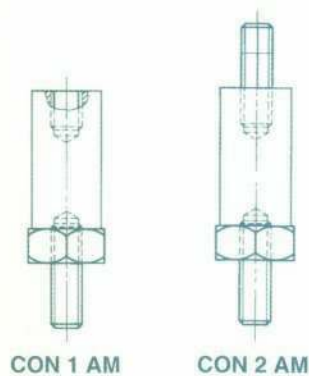
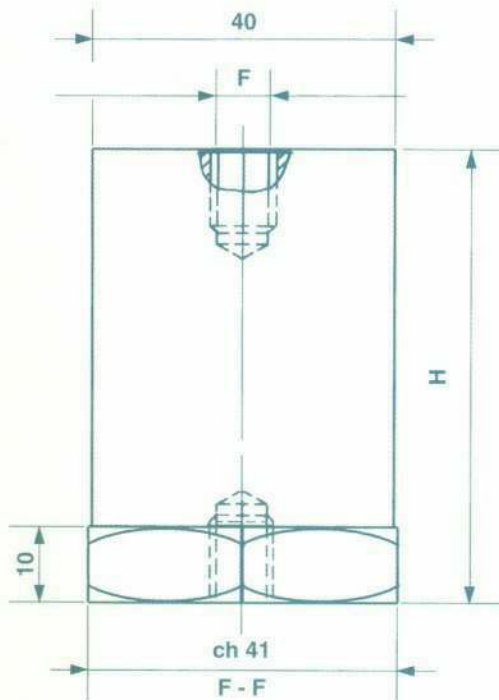

CT/P DIAMETRO 40

Realizzate in polivetro massa poliestere, rinforzata con fibre di vetro, colore rosso.

Made in polyester material reinforced with fiberglass, red color.

Articolo Article	F	H	Tensione di esercizio Operating voltage
CT/P 30	M 8 M 10	30 mm	750 V
CT/P 35	M 8 M 10	35 mm	750 V
CT/P 40	M 8 M 10	40 mm	1000 V
CT/P 45	M 8 M 10	45 mm	1000 V
CT/P 50	M 8 M 10	50 mm	1500 V
CT/P 55	M 8 M 10	55 mm	1500 V
CT/P 60	M 8 M 10	60 mm	1500 V
CT/P 65	M 8 M 10	65 mm	1500 V
CT/P 70	M 8 M 10	70 mm	1500 V

Colonnine Distanziatrici Tipo CPE - Ø 60

Spacing Stud Bolts Type CPE - Ø 60

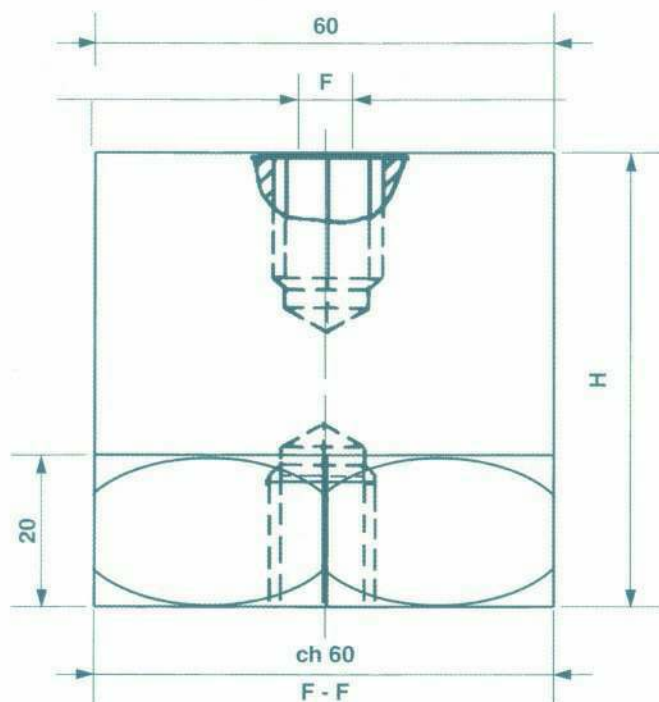

CPE DIAMETRO 60

Realizzate in polivetro massa poliestere, rinforzata con fibre di vetro, colore rosso.

Made in polyester material reinforced with fiberglass, red color.

Articolo Article	F	H	Tensione di esercizio Operating voltage
CPE 40	M 10 M 12 M 16	40 mm	1500 V
CPE 60	M 10 M 12 M 16	60 mm	3000 V
CPE 80	M 10 M 12 M 16	80 mm	5000 V
CPE 100	M 10 M 12 M 16	100 mm	8000 V

Colonnine Distanziatrici

Spacing Stud Bolts

• Sollecitazione a torsione • <i>Twisting stress</i>	DN x mm
• Sollecitazione a compressione • <i>Compressive stress</i>	DN
• Sollecitazione a flessione • <i>Cantilever stress</i>	DN
• Sollecitazione a trazione • <i>Tensile stress</i>	DN
• Tensione di scarica interna C.A. • <i>A.C. internal flashover voltage</i>	KV
• Tensione di scarica superficiale C.A. • <i>A.C. surface flashover voltage</i>	KV

Temperatura di esercizio °C: -40° +130°
Operating temperature

Reazione al fuoco Classe: UL94-VO
Fire reaction Classe: UL94-VO

Carichi di rottura (tolleranza ± 10%)
Breaking charges (allowance ± 10%)

1DN = ~ 1Kg.

CO/P 30	5	15	400	200	2.100	1 - 2
CO/P 40	8	20	400	150	2.100	1 - 2
CO/P 50	10	25	400	100	2.100	1 - 2
CO/P 60	10	30	400	100	2.100	1 - 2
CS/P 30	8	20	900	450	4.000	1,3 - 2,6
CS/P 40	8	25	900	300	4.000	1,3 - 2,6
CS/P 50	10	35	900	200	4.000	1,3 - 2,6
CS/P 60	15	35	900	150	4.000	1,3 - 2,6
CT/P 30	8	20	1.000	750	8.000	3 - 6
CT/P 40	10	25	1.000	700	8.000	3 - 6
CT/P 50	10	35	1.000	500	8.000	3 - 6
CT/P 60	10	35	1.000	370	8.000	3 - 6
CPE 40	10	25	1.100	700	10.000	6
CPE 60	20	50	1.500	600	10.000	8
CPE 80	25	50	2.300	900	12.000	10
CPE 100	30	50	3.000	1.500	15.000	15

Isolatori Passanti Tipo PI/P

Passing Insulators Type PI/P

Isolatore Passante Tipo PI/P in massa colore rosso.
Passing insulator type PI/P in polyester material red colour.

Foratura Pannello
Panel drilling.

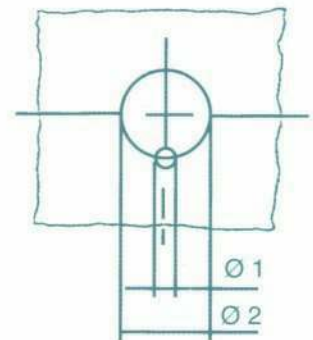
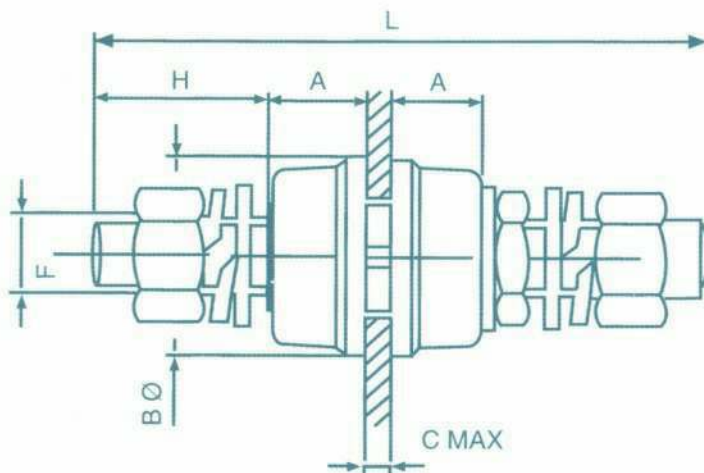

ART. ITEM	F	L
PI/P- 4	M 4	50
PI/P- 6	M 6	65
PI/P- 8	M 8	80
PI/P- 10	M 10	95
PI/P- 12	M 12	105
PI/P- 16	M 16	135
PI/P- 20	M 20	155

PORTATA NOMINALE IN RATED RANGE	TENSIONE ESERCIZIO V V OPERATING VOLTAGE	TENSIONE PROVA V KV TEST VOLTAGE	A	B Ø	C MAX	H	Ø 1	Ø 2
25	600	4	10	15	3	12,5	2,5	8,5
50	1.000	6	12	22	5	17	3,5	12,5
80	1.000	6	13,5	25	5	21	3,5	15,5
120	1.000	6	15	30	5	28	4,5	17,5
200	1.000	6	17	35	5	29	5	20,5
300	2.000	8	22	43	7	38	5,5	25,5
450	2.000	8	25	54	8	44	6	30,5

Portasbarre Verticale Tipo PSB

Vertical Rodholders Type PSB

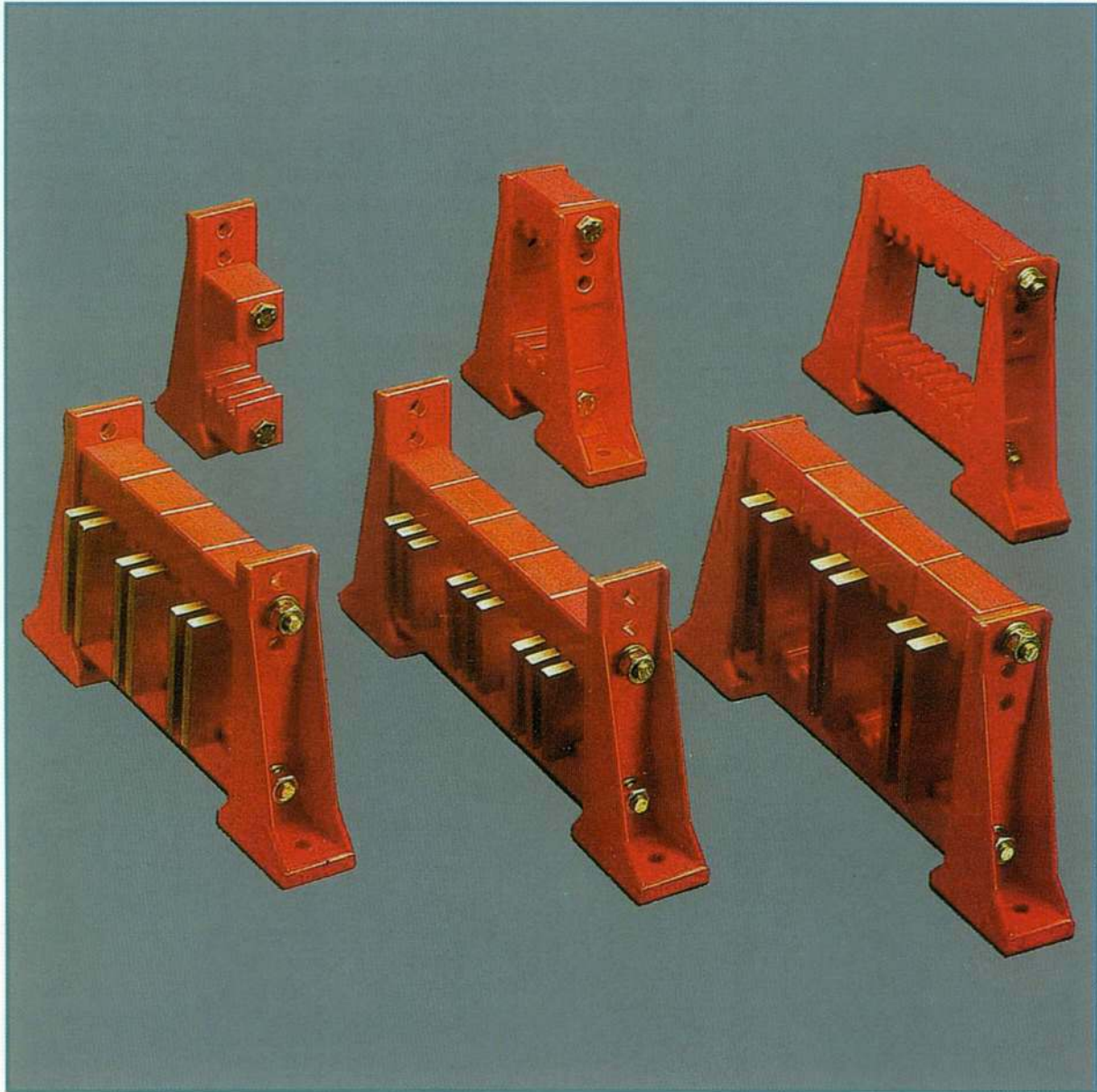

Portasbarre Verticale Tipo PSB

Vertical Rodholders Type PSB

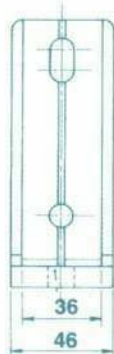

Portasbarre verticale componibile in massa poliestere rinforzata con fibre di vetro, colore rosso, adatto per sbarre nude da: mm 40 x 6 minimo a mm 120 x 10 massimo.

Questo portasbarre, per le sue caratteristiche costruttive, trova ottimo impiego dove necessitano grandi capacità di isolamento e di resistenza meccanica.

per realizzare un portasbarre occorrono: 2 spalle, 2 tiranti di assemblaggio e un numero di blocchetti necessario per formare la composizione desiderata.



Assembleable vertical rodholders in polyester material reinforced with fiberglass, red colour suitable for single and parallel rods: from mm 40 x 6 to mm 120 x 10.

this rodholder, for the construction characteristics, has an excellent employment where are needed a great insulation capacity and mechanical resistivity.

To realize a rodholder are needed: 2 lateral supports, 2 assembly screws and a necessary number of blocks required to obtain the composition of needed rods.

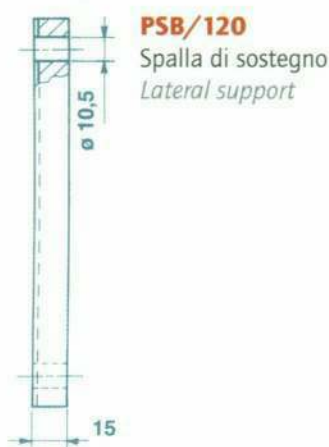

Spalla <i>Lateral Support</i>	Blocchetti <i>Blocks</i>	Sbarre <i>Rods</i>		
PSB/2	PSB 6	40 x 6	50 x 6	
	PSB 8	40 x 8	50 x 8	
	PSB 10	40 x 10	50 x 10	
PSB/1	PSB 6	60 x 6	80 x 6	100 x 6
	PSB 8	60 x 8	80 x 8	100 x 8
	PSB 10	60 x 10	80 x 10	100 x 10
PSB/120	PSB 6	120 x 6		
	PSB 8	120 x 8		
	PSB 10	120 x 10		

Portasbarre Verticale Tipo PSB

Vertical Rodholders Type PSB

PSB/6

Blocchetto sbarre mm 6
Block for rods thickness 6

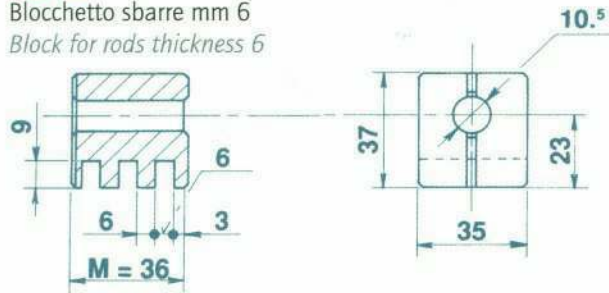

PSB/8

Blocchetto sbarre mm 8
Block for rods thickness 8

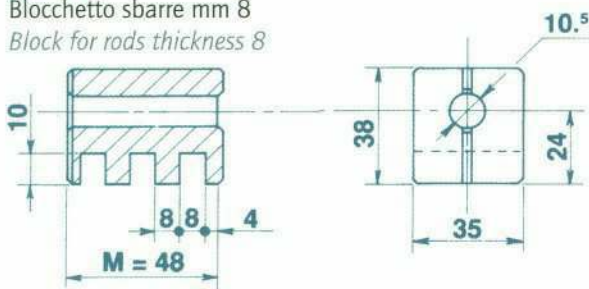

PSB/10

Blocchetto sbarre mm 10
Block for rods thickness 10

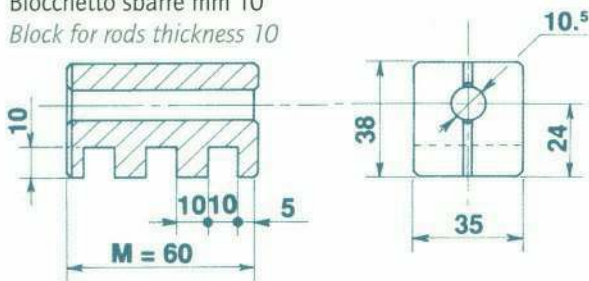

Tirante acciaio Ø 10, completo di dadi e rondelle
Steel screw Ø 10, complet with nuts and washers

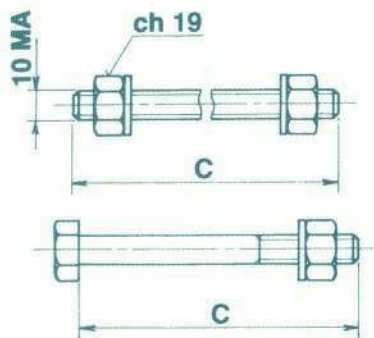

PROVE ESEGUITE SUI PSB

TESTS MADE ON PSB

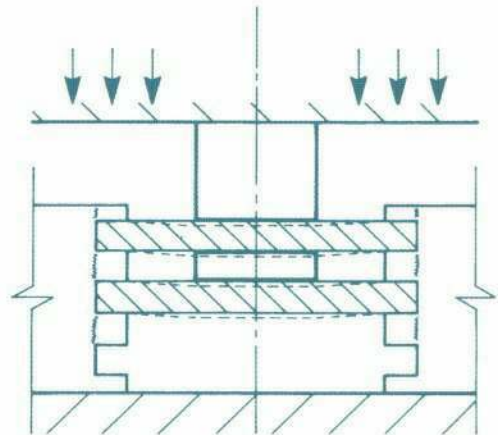

Flessione del dente con inizio rottura

Elastic deflection of the tooth with beginning of rupture

PSB/6	Kg	950
PSB/8	Kg	1130
PSB/10	Kg	1375

Tensione di esercizio 1000 V
Operating voltage 1000 V

Temperatura di esercizio °C: -40° +130°
Operating temperature

Reazione al fuoco Classe: UL94-V0
Fire reaction Classe: UL94-V0

Carichi di rottura (tolleranza ± 10%)
Cantilever stress (allowance ± 10%)

Portasbarre Verticale Tipo PSB

Vertical Rodholders Type PSB

Fig. 1

Esempio di portasbarre unipolare realizzato con 3 sbarre in parallelo.

Illustration 1

Example of unipolar rodholders made with 3 parallel rods.

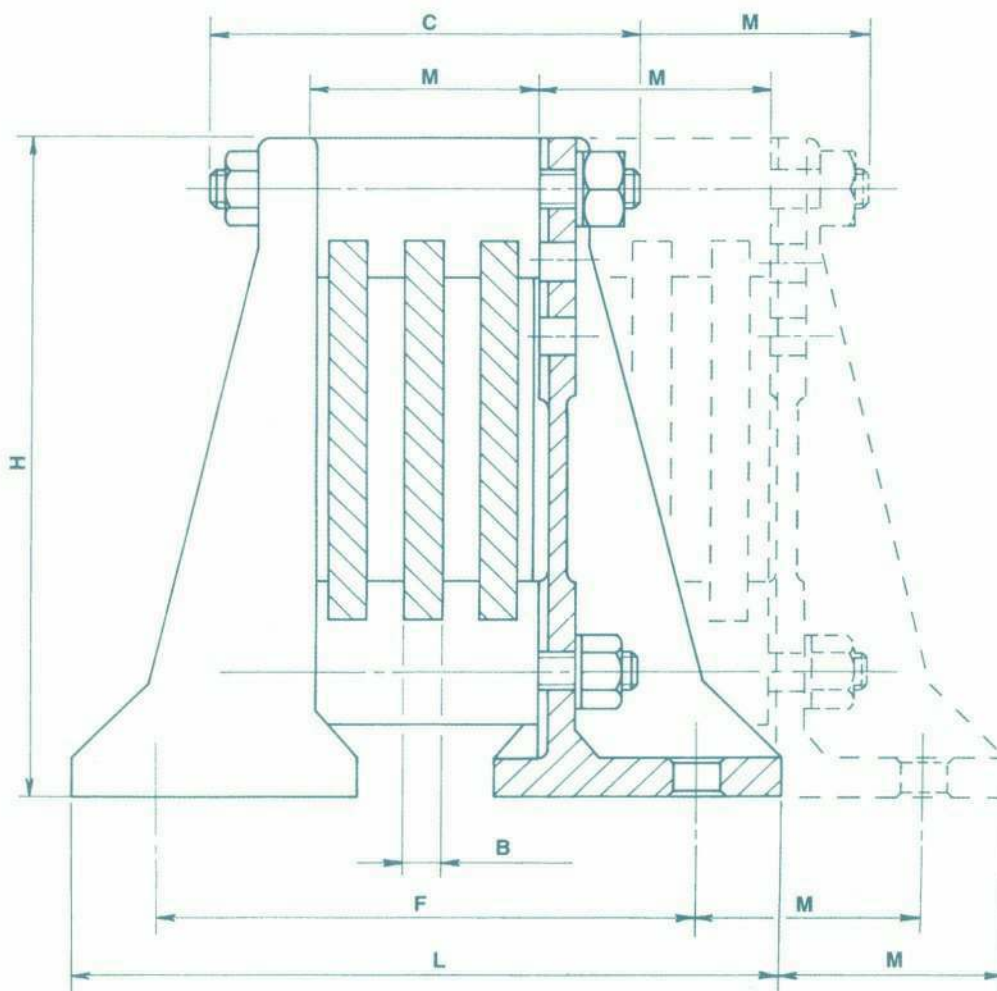

H. Con spalla di sostegno PSB 2 = 127 mm
 With lateral support PSB 1 = 177 mm

M. Con blocchetto PSB 6 = 36 mm
 With block PSB 8 = 48 mm
 PSB 10 = 60 mm

Portasbarre Verticale Tipo PSB

Vertical Rodholders Type PSB

PSB/1							
Fig	A	B	C	L	F	H	M
1	1	6	70	162	118	177	36
1	1	8	90	174	130	177	48
1	1	10	100	186	142	177	60
3	2	6	110	198	154	177	36
3	2	8	140	222	178	177	48
3	2	10	160	246	202	177	60
4	3	6	150	234	190	177	36
4	3	8	194	270	226	177	48
4	3	10	230	306	262	177	60
5	4	6	194	270	226	177	36
5	4	8	242	318	274	177	48
5	4	10	290	366	322	177	60
6	5	6	230	306	262	177	36
6	5	8	290	366	322	177	48
6	5	10	350	426	382	177	60
7	6	6	270	342	298	177	36
7	6	8	338	414	370	177	48
7	6	10	410	486	442	177	60

A = Numero blocchetti
Number of the blocks

B = Spessore sbarra
Thickness of the rod

C = Lunghezza dei tiranti
Length of the bolts

L = Ingombro esterno
Exterior encumbrance

F = Interasse fori
Distance between centers of the holes

H = Altezza
Height

M = Modulo
Module

PSB/2							
Fig	A	B	C	L	F	H	M
1	1	6	70	152	118	127	36
1	1	8	90	164	130	127	48
1	1	10	100	176	142	127	60
3	2	6	110	188	154	127	36
3	2	8	140	212	178	127	48
3	2	10	160	236	202	127	60
4	3	6	150	224	190	127	36
4	3	8	194	260	226	127	48
4	3	10	230	296	262	127	60
5	4	6	194	260	226	127	36
5	4	8	242	308	274	127	48
5	4	10	290	356	322	127	60
6	5	6	230	296	262	127	36
6	5	8	290	356	322	127	48
6	5	10	350	416	382	127	60
7	6	6	270	332	298	127	36
7	6	8	338	404	370	127	48
7	6	10	410	476	442	127	60

Portasbarre Verticale Tipo PSB

Vertical Rodholders Type PSB

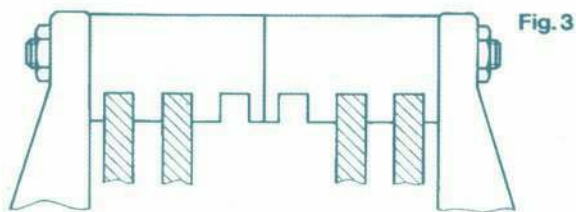
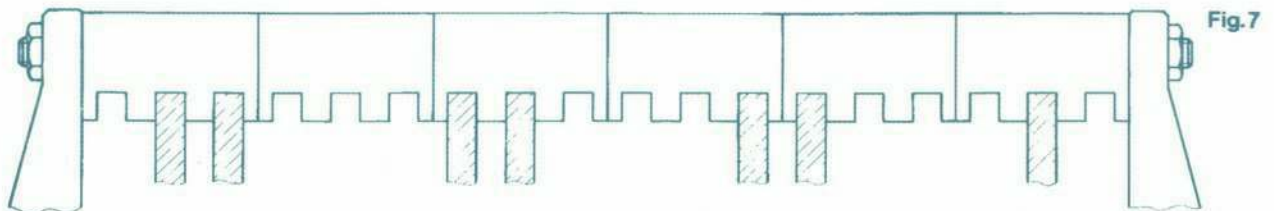
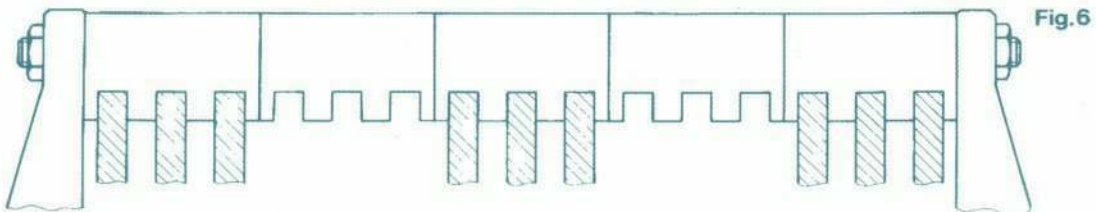
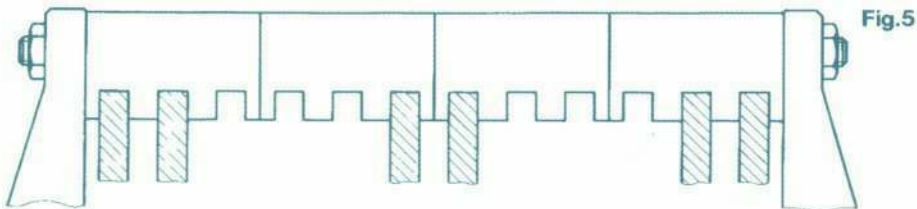
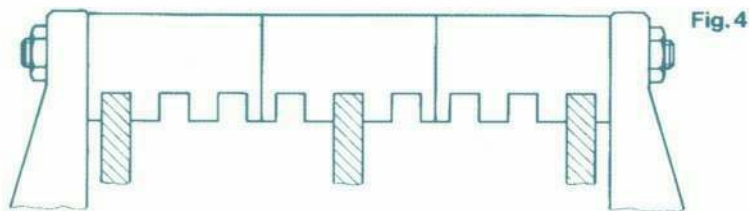

Fig. 3 - 4 - 5 - 6 - 7

Rappresentano alcune delle possibili realizzazioni.

Illustration 3 - 4 - 5 - 6 - 7

They show some of the possible realizations.



Distanziali Esagonali Metallici - Zincati

DISTANZIALI ESAGONALI IN OTTONE ZINCATI - MF -

ART.	H	F	ES.
DZ/4	15	M 4	7
DZ/4	20	M 4	7
DZ/4	25	M 4	7
DZ/4	30	M 4	7
DZ/4	50	M 4	7
DZ/4	70	M 4	7
DZ/4	90	M 4	7
DZ/5	15	M 5	8
DZ/5	20	M 5	8
DZ/5	25	M 5	8
DZ/5	30	M 5	8
DZ/5	50	M 5	8
DZ/5	70	M 5	8
DZ/5	90	M 5	8

ART.	H	F	ES.
DZ/6	15	M 6	10
DZ/6	20	M 6	10
DZ/6	25	M 6	10
DZ/6	30	M 6	10
DZ/6	50	M 6	10
DZ/6	70	M 6	10
DZ/6	90	M 6	10
DZ/8	15	M 8	13
DZ/8	20	M 8	13
DZ/8	25	M 8	13
DZ/8	30	M 8	13
DZ/8	50	M 8	13
DZ/8	70	M 8	13
DZ/8	90	M 8	13

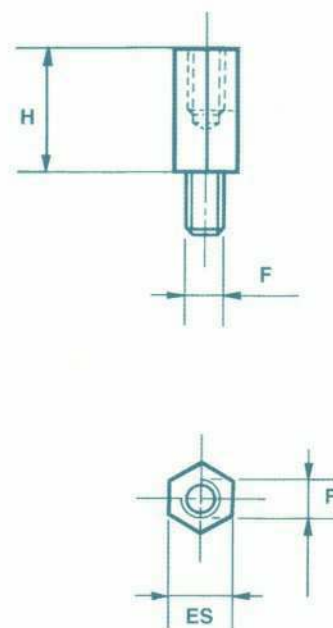

CARATTERISTICHE TECNICHE DELLA RESINA POLIESTERE CON FIBRE DI VETRO
 TECHNICAL CHARACTERISTICS OF THE POLYESTER RESIN WITH FIBERGLASS

CARATTERISTICHE CHARACTERISTICS	NORMA TEST METHOD	VALORI VALUES
REAZIONE AL FUOCO FIRE REACTION	UL 94	classe V-0
TEMPERATURA DI ESERCIZIO OPERATING TEMPERATURE	VDE 0304 section 21	"C 130
COLORE COLOUR	RAL 3002	rosso red
RESISTENZA ALL'ARCO ARC RESISTANCE	ASTM D-495	sec > 180
RESISTENZA ALLA TRACCIA TRACKING RESISTANCE	ASTM D-2303	minuti > 300
RIGIDITÀ DIELETRICA DIELECTRIC STRENGTH	UNI 4291	Kv/mm 12
ASSORBIMENTO D'ACQUA WATER ABSORPTION	ASTM D-570	< 0,2%
RESISTENZA ALL'URTO IMPACT STRENGTH	DIN 53453 ISO R 179	Kj/m ² 45

I DATI FORNITI SONO INFORMATIVI E PERCIÒ SENZA GARANZIA, IL CLIENTE È PERCIÒ TENUTO A SINCERARSI DELL'IDONEITÀ DEL MATERIALE SCELTO ALL'IMPIEGO PREFISSO.
 THE DATA GIVEN TO YOU ARE FOR INFORMATION ONLY AND FOR THIS MOTIF WITHOUT GUARANTEE. THE CUSTOMER MUST MAKE HIMSELF SURE ON THE FITNESS OF THE MATERIAL CHOSEN FOR THE PREDETERMINED EMPLOYMENT.

**A RICHIESTA FORNIAMO PORTASBARRE FRESATI ED ALTRI PARTICOLARI A DISEGNO RICAVATI DA LASTRA GPO-3
 WE CAN SUPPLY MILLED BUS-BAR SYSTEMS ON POLYESTER SHEETS GPO-3 ACCORDING TO CUSTOMER'S DRAWING**