

metaldyne

Experience and Expertise

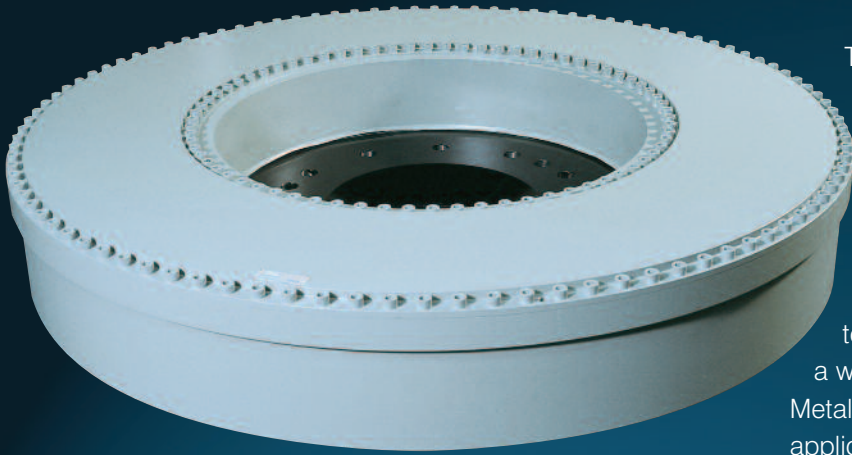

Damper size: \varnothing 2765 x 415mm

The Metaldyne damper is one of the most efficient and reliable devices for controlling resonant torsional vibration conditions and therefore extending engine life.

The Metaldyne design allows the damper to operate at a high level of efficiency over a wide range of vibration frequencies.

Metaldyne has over 40 years of design and application experience of torsional vibration dampers for slow, medium and high speed diesel engines as well as other drive line applications.

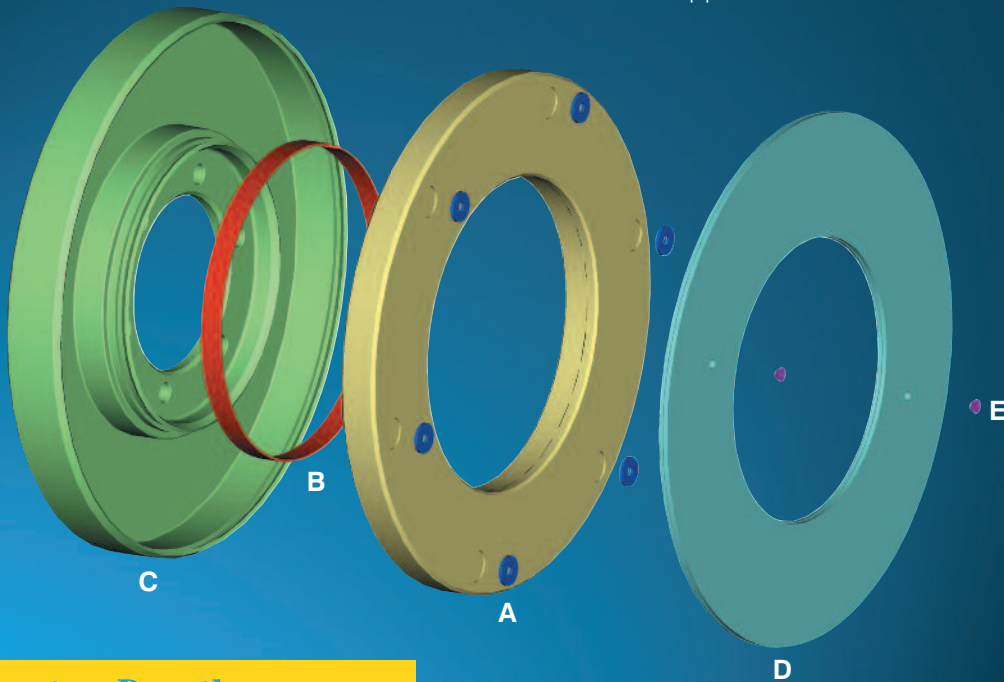

Construction Details

The Metaldyne damper consists of:-
an inertia ring (A)
freely supported and located by bearings (B)
inside the casing (C)
the casing is sealed by the cover plate (D)
which can be either rolled or bolted
screwed removable filling plugs are fitted,
where possible, to all dampers above 470mm
to allow fluid samples to be taken (E)

The clearance between the inertia ring and casing is filled with a measured amount of highly viscous silicone fluid.

Three basic methods are employed to seal the cover to the casing; welding, machine rolling or bolting. The exact method used is dependent upon damper size and customer requirements.

Principles of Operation

The Metaldyne viscous damper provides torsional vibration damping by the shearing effect of a highly viscous silicone fluid enclosed between the inner ring and outer casing. The damper casing incorporates a mounting flange which is rigidly attached to the fore end of the crankshaft and houses an inertia ring which is freely supported and located by bearings inside the casing.

Under conditions of zero torsional vibration the damper casing and inertia ring rotate at uniform velocity with the viscous fluid transferring the torque between them.

As the engine speed changes to a point where torsional vibration is present the crankshaft and damper casing are subject to torsional oscillation superimposed on the mean rotation.

Because of its inertia effects the inner ring continues to rotate at a constant angular velocity creating an oscillating anti-phase movement between itself and the casing.

This relative movement shears the film of silicone fluid, absorbing vibration energy which is dissipated as heat through the external surfaces of the damper casing.

Dissipation of heat is critical to the efficient life of the damper.

Analysis Expertise

Metaldyne's calculation programmes analyse the steady state torsional vibration characteristics by the classical resonant analysis and by the more sophisticated Forced/Damped torsional vibration analysis technique. This approach assures the customer of the most cost effective solution for their specific applications.

Metaldyne also pioneered the application of large (>2 metre) viscous torsional vibration dampers for large slow speed 2 and 4 stroke engines to control torsional vibrations in the propeller and intermediate shafts on propulsion systems.

Design Skills

Metaldyne has a vast experience in the application and design of viscous torsional vibration dampers on high, medium and low speed diesel engines.

Further product applications can include transmission dampers for machine tools to prevent gear chatter, vehicle (truck, trams and bus) transmission dampers to prevent harshness and noise which contribute to passenger discomfort, and diesel engine camshaft dampers to limit the stresses in the camshaft due to its self imposed torsional vibration excitation.

Customers are invited to contact Metaldyne where data requirements can be discussed and a detailed study of the torsional vibration characteristics of the system will be conducted using the latest in-house computer programmes.

This is a specific requirement for large 2 stroke engines.

Applied Technology

Customers are assured of optimum solutions to their duty cycle needs with Metaldyne's applied technology.

- In-house torsional vibration programmes
- Finite element design tools
- Expertise to confirm predictions by measurement
- NVH evaluation tools
- Comprehensive rig testing
- Performance & condition monitoring

Photograph courtesy of M.A.N. B&W Copenhagen



metaldyne

Dimensional and Technical Data

(D) Outer Dia. [mm]	(Dm) Minor Dia. [mm]	(W) Width (mm)	(Rd) Recess Dia. (mm)	Ring Inertia (kgm ²)	Case Inertia (kgm ²)	Effective Inertia (kgm ²)	Ring Area (m ²)	Surface Area (m ²)	Clearance Factor (m ³)	Weight (kg)
330	Rolled	51	184	0.233	0.15	0.267	0.159	0.2	10.31	21.86
355	Rolled	60	184	0.389	0.236	0.432	0.194	0.25	8.77	29.86
356	Welded	62.5	184.34	0.389	0.269	0.463	0.196	0.252	8.77	33.6
400	Rolled	65	210	0.8	0.37	0.77	0.252	0.29	20	48.4
460	Rolled	70	216	1.42	0.81	1.52	0.324	0.4	19.5	65
471	454	95	218	1.905	1.135	2.088	0.363	0.45	31	97
489	Rolled	87	254	2.323	1.166	2.328	0.373	0.48	44	94
508	Rolled	75	254	2.481	1.226	2.467	0.404	0.48	50.4	95
515	496	75	255	1.962	1.373	2.354	0.36	0.46	43	94
520	Rolled	80	280	2.64	1.47	2.79	0.404	0.503	51	98
520	520	110	325	2.6	1.87	3.17	0.404	0.551	63.3	104
555	540	100	254	4	2.39	4.39	0.487	0.61	70	149
580	Rolled	60	349	2.28	2.16	3.3	0.351	0.51	65	80
585	580	100	330	4.66	3.36	5.69	0.5	0.654	91.25	148
590	575	150	316	7.9	3.6	7.55	0.657	0.78	91	224
600	Welded	90	300	4.72	2.88	5.24	0.541	0.679	45.8	139.13
620	604	95	325	5.79	3.53	6.42	0.54	0.68	75	160
635	619	100	395	5.59	4.22	7.01	0.52	0.68	81	153
636	616	127	310	7.97	5.01	8.997	0.6	0.81	122	217
645	629	100	388	6.45	4.31	7.53	0.56	0.7	109	165
645	635	105	308	7.6	4.85	8.65	0.625	0.8	108	205
665	650	95	343	7.63	4.81	8.62	0.62	0.78	106	195
690	675	80	450	5.8	5.5	8.4	0.51	0.68	95.5	159
690	675	110	388	10	6	11	0.675	0.85	122	210
700	686	120	460	9.87	7.85	12.78	0.656	0.84	169	235
700	683	155	440	12.05	8.75	14.775	0.787	1.021	185.46	273
710	695	125	350	13.46	7.99	14.72	0.785	0.98	180	291
720	706	135	350	15.98	8.72	16.71	0.848	1.04	171	325
730	722	135	400	16.97	9.02	17.5	0.854	1.04	190	322
740	726	110	400	12.84	9.07	15.49	0.738	0.97	153	269
750	750	100	390	14.22	8.53	15.65	0.764	1	174	265
750	750	130	410	19.42	8.54	18.25	0.901	1.093	190	324
760	746	165	432	23.15	12.26	23.84	0.978	1.19	243	392
762	746	120	440	16	9.94	17.94	0.81	1.02	201	285
770	756	90	500	9.73	9.29	14.16	0.62	0.86	174	192
770	756	120	432	16.96	10.59	19.07	0.84	1.05	193	304
790	777	115	502	15.1	12.94	20.49	0.765	1.01	174	276
790	787	140	440	22	15.4	26.4	0.925	1.21	251	388
790	767	180	474	25.5	17.1	29.85	1.02	1.27	287	440
800	785	115	440	19.6	12	21.7	0.893	1.11	232	338
800	790	140	440	21.2	17.5	28	0.92	1.22	251	390
800	790	160	330	30	17	32	1.13	1.37	239	520
810	800	170	440	27.3	22.1	35.7	1.03	1.36	250	495
845	822	160	440	34.32	18.83	35.99	1.138	1.463	307	497
850	836	160	435	38	16	35	1.2	1.44	320	505
850	827	185	440	42	21	42	1.26	1.51	343	590
850	835	210	420	43	32	53	1.28	1.65	354	694
860	840	120	500	26	16	29	0.97	1.22	265	370
860	838	175	460	40.5	21.8	42	1.22	1.48	349	571
900	885	155	450	44	25	47	1.26	1.56	349	575
910	889	120	500	31	23	39	1.07	1.37	332	431
950	927	160	670	37.5	33.2	52	1.11	1.45	327	455
960	937	140	630	39.49	32.21	51.96	1.12	1.44	451	493
965	940	165	505	54	41	68	1.33	1.74	469	688
975	948	235	475	92.18	47.76	93.85	1.75	2.11	606	1018
995	980	210	500	78.5	63.42	102.7	1.58	2.09	6.21	1003
996	977	150	520	62.39	37.18	68.38	1.44	1.78	526	672

(D) Outer Dia. [mm]	(Dm) Minor Dia. [mm]	(W) Width (mm)	(Rd) Recess Dia. (mm)	Ring Inertia (kgm ²)	Case Inertia (kgm ²)	Effective Inertia (kgm ²)	Ring Area (m ²)	Surface Area (m ²)	Clearance Factor (m ³)	Weight (kg)
1020	1003	200	520	96.7	49.3	97.65	1.73	2.11	606	948
1070	1064	149	592	78.5	45	84.25	1.792	2.026	579	714
1075	1054	165	600	77.96	68.11	107	1.51	2.04	613	835
1100	1073	200	600	109.7	64.7	119.55	1.856	2.403	735	960
1105	1080	215	445	135.4	89.3	157	2.02	255	772	1340
1140	1120	215	450	173.6	82.89	169.7	2.28	2.17	889	1424
1180	1157	140	695	91.04	87.5	133	1.58	2.16	761	849
1190	1165	140	692	90.7	91.83	137.2	1.56	2.2	775	849
1200	1175	180	630	155.6	93.94	171.7	2.07	2.57	968	1166
1270	1244	160	629	158.8	128.7	208	2.13	2.75	1088	1196
1300	1280	210	600	256.8	149.6	278	2.52	3.25	1299	1592
1350	1335	160	850	208.5	135	239	2.26	2.76	1477	1162
1410	1389	180	720	306.4	179.3	332.5	2.77	3.14	1547	1594
1515	1480	240	875	459.9	351.7	581.7	3.07	4.01	2067	2296
1530	1508	230	940	474.4	337.5	574.7	3.09	3.95	2243	2195
1650	1620	300	950	889.6	547.5	992.3	4.09	5.13	2676	3404
1860	1839	360	1000	1873	981	1917	5.61	6.95	4440	5574
1980	1961	360	1180	2239	1351	2470	5.73	8	5904	5987
2100	2066	350	1100	2825	1747	3160	6.54	8.68	6480	7235
2160	2124	350	1340	2852	1861	3287	6.28	8.07	5243	6347
2200	2170	350	1000	3436	2110	3828	7.3	9.31	6141	7864
2280	2262	380	1181	4598	2520	4819	8.05	9.96	10327	8851
2300	2270	350	1086	4286	2171	4314	7.88	9.93	10245	8432
2450	2424	380	1470	4448	3919	6142	7.37	10.48	11459	8700
2560	2538	360	1270	6432	4026	7242	9	11.89	12076	10552
2650	2634	390	1160	8788	4802	9196	10.75	13.43	13014	13263
2700	2676	360	1750	6845	5292	8714	8.76	11.44	14346	9882
2765	2750	415	1750	8796	6479	10877	9.78	12.94	13938	12303
2770	2756	460	1750	10290	6768	11913	10.58	13.63	15844	13615
2900	2900	435	1750	12330	7618	13783	11.511	14.754	12703	13694
2990	2990	460	1750	15220	9223	16876	12.56	16.05	19200	17086
3000	3000	435	1590	14712	9417	16773	12.7	16.439	14902	17011
3200	3200	400	1920	17270	10690	19325	13.21	16.73	22687	17286
3200	3200	490	1800	21873	12781	23718	14.98	18.692	24590	21976
3200	3200	500	1920	22483	12140	23928	16.44	18.34	21034	20995

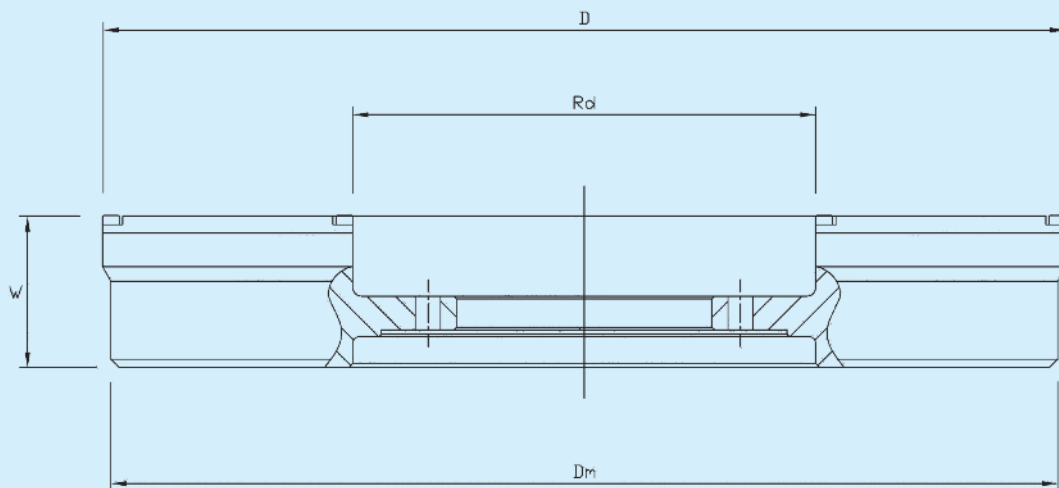

Note: For rolled dampers $D_m = D$

Bore diameter, flange position and width to suit customer requirements.

Counter balance weights can be attached to the damper however, dimension (Rd) will need to be reduced to accommodate this.

Different sizes of damper can be manufactured by Metaldyne International (UK) Ltd. to suit the particular application.



Application: Viscous damper for Truck Engine: OM936

Damper size: \varnothing 256 x 52 mm

metaldyne

METALDYNE INTERNATIONAL (UK) LTD

FORMERLY

SIMPSON
INDUSTRIES

HOLSET

Metaldyne International (UK) Ltd

Service Department

131 Parkinson Lane, Halifax, West Yorkshire, HX1 3RD, England

Tel: +44 (0)1422 357234 Tel: +44 (0)1422 395106

Fax: +44 (0)1422 354432

damperservice@metaldyne.com

www.metaldyne.co.uk