



VERDERMAG

Mag Drive Centrifugal Pumps



Verdermag

Mag Drive Centrifugal Pumps

The series of mag drive centrifugal pumps from Verder consists of a wide range of both metallic and non metallic pumps. Verder has more than 40 years of experience in mag drive centrifugal pumps and is an expert in choosing the most adequate pump for your pumping application.



The Verdermag series of pumps comprises the metallic Global and the non-metallic heavy duty TB, U, V&W series and the normal duty V-MD, GPMD and GLMD versions. The Verdermag range is therefore a complete, well-balanced series of magnetically coupled centrifugal pumps.

As with all series of Verdermag centrifugal pumps, emphasis is on maximum interchangeability and quality improvements, hence all products are covered by a two-year guarantee, as well as the standard Verder warranty package.

Features and advantages

- Simple by design - Fewer parts are used in the whole pump than most conventional seal cartridges ensuring easy maintenance and assembly
- Mag drive coupled: completely leak free

Mag drive centrifugal pumps are being used in a wide range of industrial areas:

Chemical industry

Acrylic acid, 50% aluminum chloride, hydrofluoric acid 50%, hydrogen sulfide, 85%, sulfuric acid, 98%, ammonia, phosphate and many others

Electronics industry

Plating, etching, ferric chloride, hydrochloric acid 37%, sodium hydroxide 50%

Mining

Brine with uranium solids, H₂O, soda ash, HCl

Galvanic industry

Plating, etching, filtration

Pharmaceutical industry

Sodium hydroxide 50%, caustic soda, hot oil, solvents

Steel industry

Hydro chloric acid, pickling liquor, sulfuric acid



Working principle

Although each mag drive pump series -depending on its design- has its own characteristics, all mag drive pumps work with a magnetic coupling.

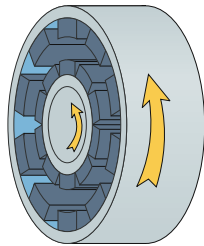
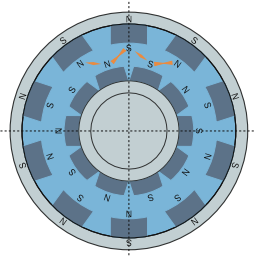
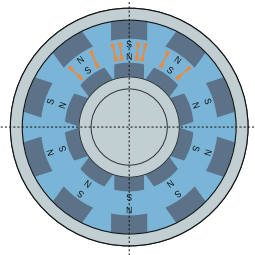

The principle of a magnetic coupling

A magnetic coupling consists of two magnet assemblies. One is the outer assembly (the drive magnet) and the other is the inner assembly (the driven magnet). The outer assembly is connected to a motor and the inner assembly is directly or indirectly attached to a pump impeller. As illustrated, at rest, the magnet components of the outer assembly are aligned with their counterparts in the inner assembly. When load (torque) is applied, the coupling deflects angularly and the magnets create a force of simultaneous attraction and repulsion. This force is used to transfer torque from the motor to the impeller.

This permanent magnet coupling creates neither slippage nor induction currents during rotation. If excessive torque is applied, the magnets will de-couple. The magnets will not re-couple unless the pump is stopped. There is no energy loss in a permanent coupling unless an electrically conductive containment is placed between the outer and inner magnets. If an electrically conductive material is used for the containment, Eddy Currents will be generated which will cause some energy loss.

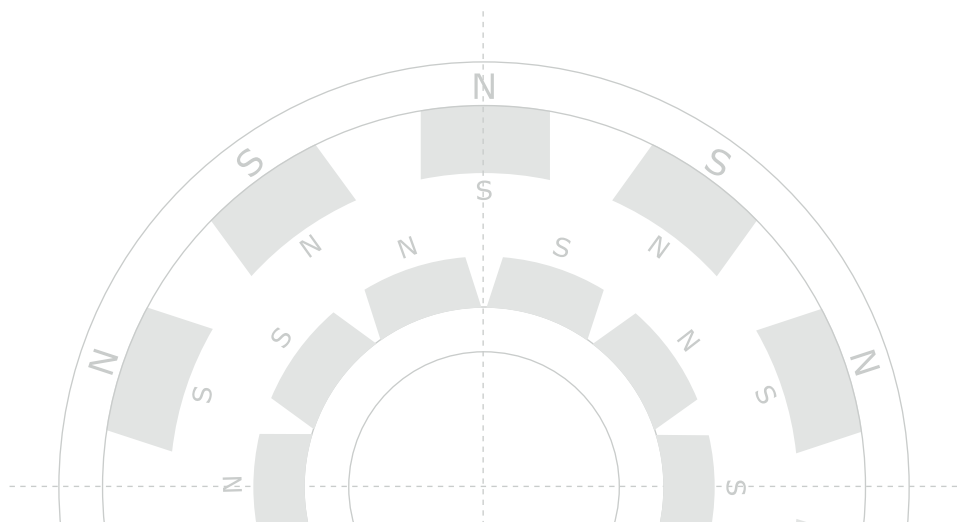



OVERVIEW OF PUMP SERIES

Series V-MD

The wide choice of V-MD pumps is based upon the most common OEM requirements for optimum flow and head characteristics. At least 10 models are available in PP and/ or E-TFE. The major advantage for using the V-MD pumps is total product containment; no unexpected leakage. Connections are hose design or threaded.



Flow range	up to 100 l/min
Heads	up to 14 m

Series GPMD and GLMD

The GPMD and GLMD series are mid capacity mag drive pumps with a very good price/quality relation. The pumps are available in PP and ETFE (GPMD) and in ETFE lined cast iron casing (GLMD). In general design the GPMD and GLMD models do have some interchangeable parts when comparing ETFE built versions.



Flow range	up to 1500 l/min
Heads	up to 40 m

Series TB, U and V&W

Verder offers you the newest mag drive series, with thrust balancing (TB series) and universal purpose pumps (U series). Also available is the V&W series, based upon the TB series, vertical inline pumps with the same benefits and features as the TB series. The patented Thrust Balancing Design eliminates axial thrust bearings and provides the basis for a controlled internal environment. This design minimizes the issue of secondary containment by providing secondary bearings.



Flow range	up to 300 m ³ /h
Heads	up to 110 m

Series GPSP

The GPSP self priming mag pump is a high quality mag drive centrifugal pump with best efficiency and fastest working duty points. Model GV is constructed of PP (housing material) whilst model GV(F) is constructed of ETFE. Material choice on bushing and O-ring is carbon/FPM, ceramics/FPM or PTFE/FPM to provide utmost application possibility.



Flow range	up to 440 l/min
Heads	max. 26.5 m

Series Global

Metallic mag drive series with great possibilities to cover requirements according to ISO 2858, high pressure system Pumps, and more basic pumps (style 1 Models).



Flow range	up to 70 m ³ /h
Heads	up to 100 m

VERDERMAG V-MD SERIES

The V-MD OEM mag drive pumps

A very compact, mag drive centrifugal pump. Dependent on the application these pump series can be supplied with either closed or open impeller. The electric motors are completely integrated and are fed with a power supply of 230/240 V, 50 Hz. All types can be supplied with threaded or hose connection.

The wide choice of V-MD pumps is based upon the most common OEM requirement for optimum flow and head characteristics. The major advantage for using the V-MD pumps is total product containment; no unexpected leakage. Even for flows up to 100 l/min the models are still compact due to the close coupled electric motors. The process connections are standard hose design, but the larger models in particular can also be supplied with threaded connections. Motor specifications are standard single phase (100–110 V and 220–240 V), 50 to 60 Hz for use worldwide. For optimum efficiency and lower heat input the smaller models can be operated with DC drives. The maximum voltage is 24 V, this results in an operating speed of 4.000 rpm. This is much higher than the 2.500 rpm at 50 cycles with AC drives.

Features and advantages

- Total product containment
- Excellent for OEM requirements in flow and characteristics
- No leakage
- Compact but very reliable
- Small pump with gigantic possibilities
- UL-VDE approved

Applications

- OEM
- Chemical processing
- Metal plating
- Parts washing
- Circuit boards
- Photo processing
- Pharmaceuticals
- Food processing

Technical specifications

Flow range	0.01 – 100 l/min
Head	up to 20 m
Temperature	0 to 70 °C
Power supply	100-110 / 220- 240 Volt or 24 Volt DC (at 4000 rpm)

Cut away view

- 1 front casing
- 2 impeller
- 3 rear casing
- 4 O-ring
- 5 shaft
- 6 outer magnet
- 7 motor

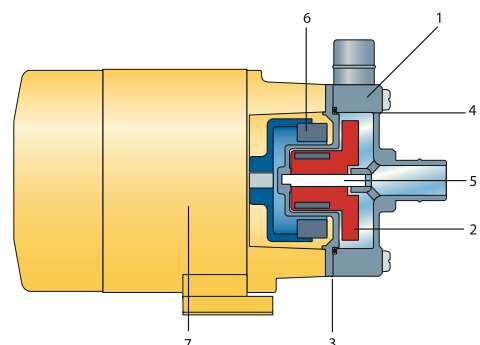

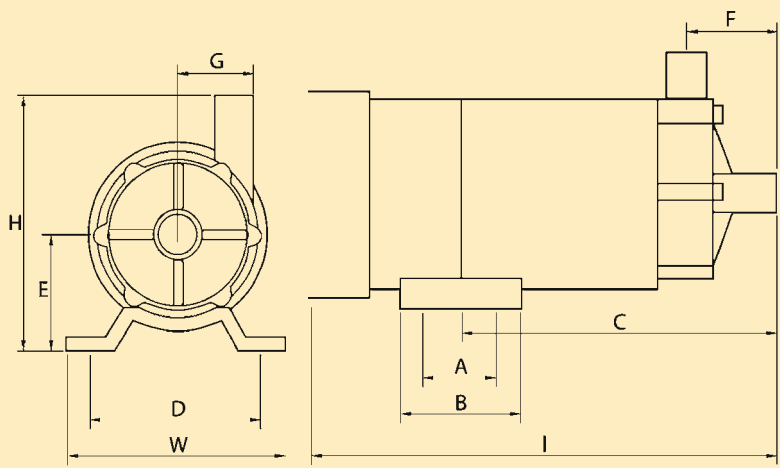

Type	W	H	L	A	B	C	D	E	F	G	connections	hose thread
V-MD 6	74	92	145	-	30	73	60	45	31	17	14	1/2"
V-MD 6C	74	92	145	-	30	73	60	45	31	17	14	1/2"
V-MD 10	74	92	145	-	30	73	60	45	31	17	14	1/2"
V-MD*6C/10	74	110**	104	-	30	65	60	45	24	17	14	1/2"
V-MD 15	95	114	195	-	50	117	85	55	38.5	21.5	14	3/4"
V-MD 20	95	115	210	30	50	131.5	68	55	38.5	28.5	18	3/4"
V-MD 30	120	130	245	40	64	169	100	60	48	31	20	3/4"
V-MD 40	120	130	260	40	64	169	100	60	48	31	20	3/4"
V-MD 20C	95	125	225	30	50	134	68	55	39.5	38.5	18	3/4"
V-MD 30C	120	130	230	40	64	152	100	60	39.5	38.5	18	3/4"
V-MD 40C	120	130	236	40	64	152	100	60	40	38.5	18	3/4"
V-MD 55	120	164	300	40	64	199	100	66	70	43.5	25	1"
V-MD 1090	156	168	355	70	100	205	110	69.5	70	43.5	25	1"
V-MD 1235	156	168	355	70	100	205	110	69.5	70	43.5	25	1"
V-MD 2050	320	175	385	50	110	200	220	75	55	59	25	1"
V-MD 100	156	165	365	70	100	195	110	66	70	43.5	26	1"

dimensions in mm * short model ** capacitor housing

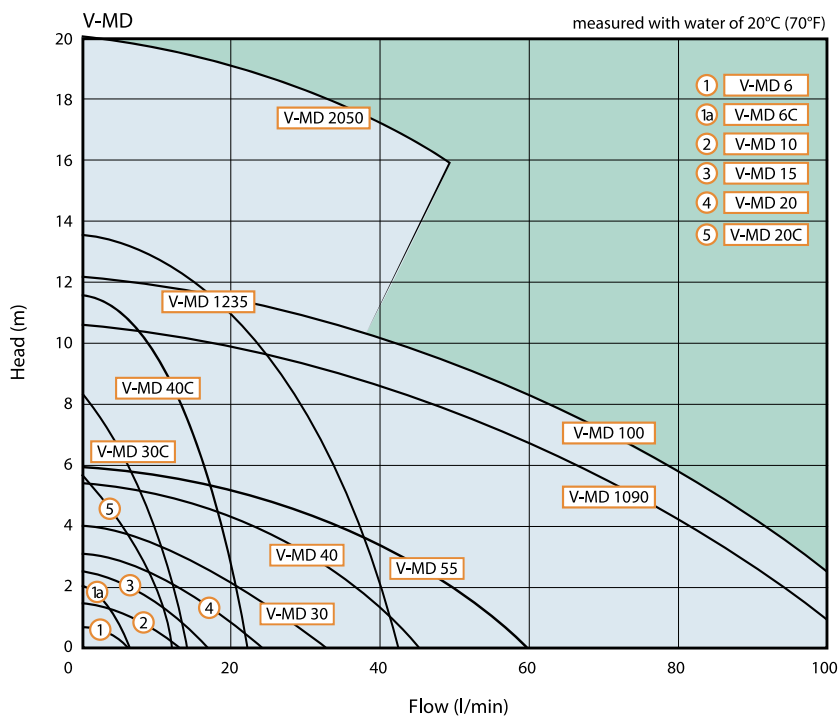

VERDERMAG GPMD and GLMD SERIES

The GPMD/GLMD models are mid capacity mag drive pumps with a very good price/quality relation. The pumps are available in PP and ETFE (GPMD) and in ETFE lined cast iron casing (GLMD). In general design the GPMD and GLMD models do have some interchangeable parts when comparing ETFE built versions.

Most major storage of concentrated chemicals is done in tank farms, located outside of the production facilities for safety and logistical reasons. The GLMD/GPMD pumps are used to pump these liquids into the plant, where the liquids are used for production. The majority of liquids are: acids, like hydrochloric acid, sulphuric acid, nitric acid, phosphoric acid and bases, like sodium hydroxide, potassium hydroxide etc. from virtually zero to full concentration.

Model GPMD

The GPMD model is available in both polypropylene and ETFE and is notable for its solid plastic front casings. The process connections are standard threaded flanged with slotted holes to accommodate DIN, ANSI and JIS contra-flange specifications. Thread connections are available as well. The polypropylene components are injection moulded with glass fibre reinforcement, the E-TFE material is reinforced with carbon fibre. Most chemicals can be transferred with these material options.

Model GLMD

The stationary ceramic shaft design avoids complex internal design, as the single sleeve bearing is fitted into the internal magnet. The standard material for this sleeve bearing is high density carbon, this has self-lubricating possibilities if process flows are reduced. The front- and rear casing are sealed by just 1 static o-ring in Viton. The injection moulded ETFE components, such as front casing liner, rear casing, impeller and internal magnet are reinforced with 20% carbon fibre to give optimum strength and temperature resistance. The maximum liquid temperature limit is therefore 90°C.

Technical specifications

	GPMD	GLMD
Flow range	1300 l/min	1500 l/min
Head	up to 30 m	up to 40 m
Temperature	up to 90 °C	up to 90 °C
Operating temp.	max. 6 bar	max. 6 bar
Power supply	up to 11 kW	up to 11 kW



Features and advantages

- Suitable for most chemicals
- Standard is threaded flange with slotted holes (thread only connections can be offered upon request) for GPMD, Metal-lined casing with fixed flanges (GLMD)
- Main sealing through only 1 static o-ring in Viton® (optional EPDM)
- Standard installed carbon graphite for the single sleeve bearing (optional SiC and ceramic)
- Max. of 0.5% of solids by volume
- Particle size should be limited to 50 microns
- Eddy Current losses of max. 2% (GLMD)
- All units are close coupled
- Magnet coupling of Samarium Cobalt (> 4 kW at 50 Hz) or Barium Ferrite (< 4 kW)

Applications

- Chemical industry
- Pharmaceuticals
- OEM
- Tank emptying
- Food processing

Model GPMD

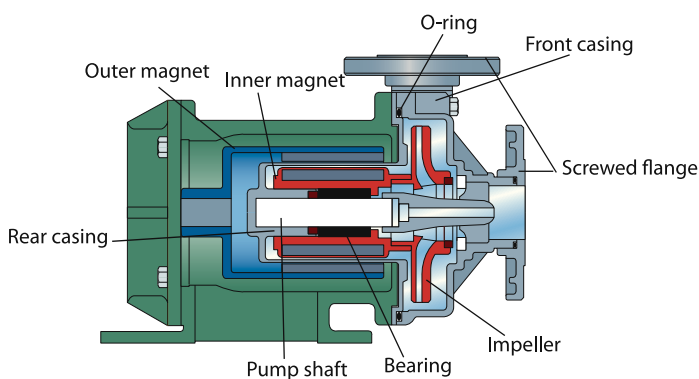

Model GLMD

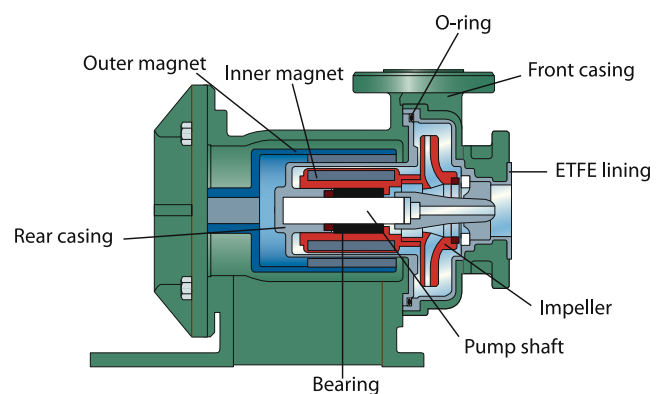

VERDERMAG MODEL GPMD

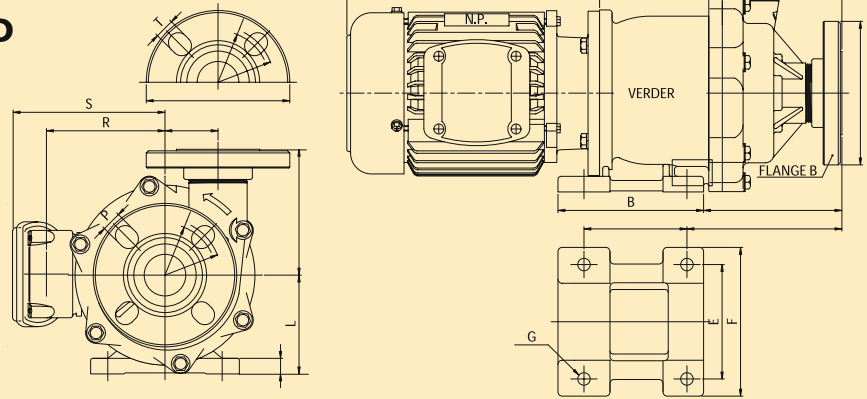

Type	Connections		Density kg/dm	Flow-m ³ /h		BEP		Temp. °C	Motor kW	Max. syst. Press. Bar
	Suction	Discharge		Min.	Max.	H(m)	(L/min)			
18-120	DN 25	DN25	1,1	1,2	7,2	11	80	*	0,37	2,7
22-140	DN 25	DN25	1,1	1,2	8,4	17	100	*	0,75	3,3
10-200	DN 40	DN 40	1.2	1,2	16	7.4	135	*	0.55	1,7
			1.5			6.5	135			
			1.9			4.7	120			
15-250	DN 40	DN 40	1.2	1,2	21	10	180	*	1.1	2
			1.5			8.5	160			
			1.9			6	175			
20-450	DN 50	DN 40	1.2	3	28	16	260	*	1.5	3,3
			1.5			13	240			
			1.9			10	280			
25-500	DN 50	DN 40	1.2	3	32	17	330	*	2.2	3,7
			1.5			15	310			
			1.9			14	280			
30-600	DN 50	DN 40	1.2	3	28	24	390	*	4	4,5
			1.5			20	350			
			1.9			15	220			
25-700	DN 65	DN 50	1.2	3	45	21	500	*	4	4
			1.5			16	500			
			1.9			13	500			
32-400	DN 65	DN 50	1.2	6	24	33	350	*	5,5	4,5
			1.5			20	350			
			1.9			0	350			
30-950	DN 65	DN 50	1.2	6	57	22	600	*	5,5	4,5
			1.5			19	600			
			1.9			16	600			
24-800	DN 80	DN 65	1.2	3	48	12	600	*	4	4,5
			1.5			11	540			
			1.9							
26-1000	DN 80	DN 65	1.2	3	60	17	700	*	5.5	4,5
			1.5			15	625			
			1.9			11	660			
30-1300	DN 80	DN 65	1.2	3	78	24	760	*	7.5	4,5
			1.5			19	720			
			1.9			15	660			
35-1300	DN 80	DN 65	1.2	3	78	27	1080	*	11	4,5
			1.5			26	815			
			1.9			24	600			

* means 70°C for PP and 90°C for ETFE

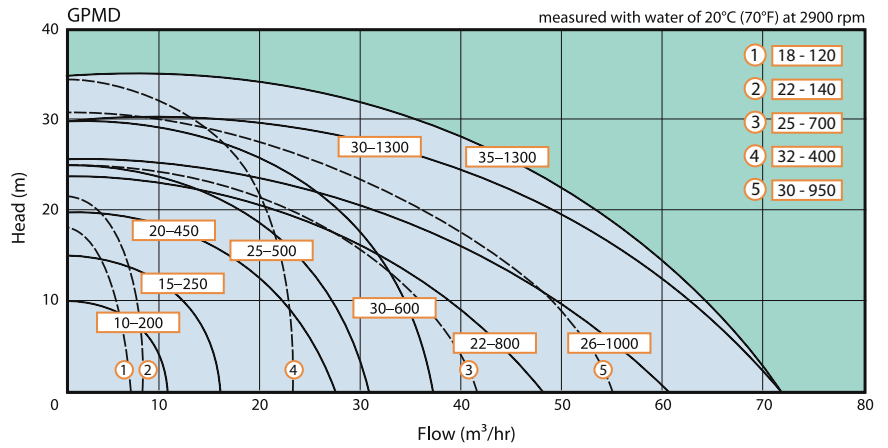

Type	A	B	C	D	E	F	G	H	I	J	K	L	M	N
18-120	133	181,5	164	130	130	157	4 x 12	122	92	235	14	115	142	R 44
22-140	140	182,5	173,5	130	130	160	4 x 12	122	92	240	14	115	140	R 44
10-200	133	140	150	98	110	140	4 x 12	137	87	233	14	95	121	R 54
15-250	160	175	184	130	130	160	4 x 12	137	102,5	256	14	115	139	R 54
20-450	133	245	158	200	208	260	4 x 14	152	89	305	16	115	140	R 61
25-500	133	245	158	200	208	260	4 x 14	152	89	305	16	115	140	R 61
30-600	135	245	158	200	208	260	4 x 14	152	89	326	18	130	140	R 61
25-700	93	360	123	300	220	260	4 x 14	180	89,5	287,5	17	162	157	R 72,5
32-400	93	360	123	300	220	260	4 x 14	180	89,5	287,5	17	162	157	R 72,5
30-950	93	360	123	300	220	260	4 x 14	180	89,5	311,5	17	162	157	R 72,5
24-800	215	325	240	270	210	260	4 x 14	190	118	360	20	175	185	R 80
26-1000	215	325	240	270	210	260	4 x 14	190	118	380	20	175	185	R 80
30-1300	215	325	240	270	210	260	4 x 14	190	118	380	20	175	185	R 80
35-1300	215	325	240	270	300	350	4 x 14	190	118	409	20	200	185	R 80

	O	P	Q	R	S	T	U	V	W	X	Flange A	Flange B
18-120	R 39	19	76	114	146	19	R 39	R 44	122	475	DN 25	DN 25
22-140	R 39	19	76	118	152	19	R 39	R 44	122	472	DN 25	DN 25
10-200	R 49,5	19	51	114	102	19	R 49,5	R 54	137	416	DN 40	DN 40
15-250	R 49,5	19	57,5	118	123	19	R 49,5	R 54	137	471	DN 40	DN 40
20-450	R 56	19	65	138	133	19	R 49,5	R 54	137	543	DN 50	DN 40
25-500	R 56	19	65	138	133	19	R 49,5	R 54	137	570	DN 50	DN 40
30-600	R 56	19	65	160	138	19	R 49,5	R 54	137	616	DN 50	DN 40
25-700	R 72,5	19	60	160	203	19	R 56,5	R 61,5	152	650,5	DN 65	DN 50
32-400	R 72,5	19	60	160	203	19	R 56,5	R 61,5	152	650,5	DN 65	DN 50
30-950	R 56	19	60	178	245	19	R 56,5	R 61,5	152	67605	DN 65	DN 50
24-800	R 75	19	85	160	138	19	R 70	R 72,5	180	650	DN 80	DN 65
26-1000	R 75	19	85	185	148	19	R 70	R 72,5	180	730	DN 80	DN 65
30-1300	R 75	19	85	185	148	19	R 70	R 72,5	180	730	DN 80	DN 65
35-1300	R 75	19	85	230	235	19	R 70	R 72,5	180	904	DN 80	DN 65

VERDERMAG MODEL GLMD

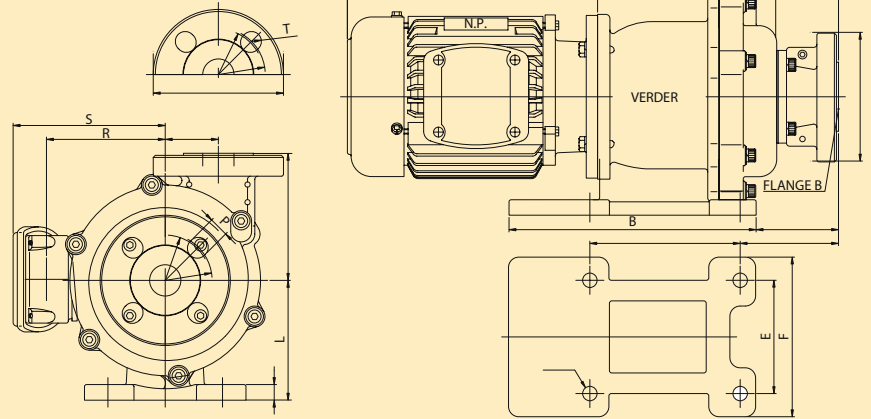

Type	Connections		Density kg/dm	Flow-m ³ /h		BEP		Temp. °C	Motor kW	Max. syst. Press. Bar
	Suction	Discharge		Min.	Max.	H(m)	(L/min)			
10-200	DN 25	DN 25	1.2	1,2	14	7	135	90	0.55	1,7
			1.5			6	140			
			1.9			5	115			
15-250	DN 40	DN 40	1.2	1,2	18	9	200	90	1.1	2
			1.5			7.6	190			
			1.9			7.7	170			
20-450	DN 50	DN 40	1.2	3	26	16	260	90	1.5	3,3
			1.5			14	260			
			1.9			11	240			
25-500	DN 50	DN 40	1.2	3	32	18	320	90	2.2	3,7
			1.5			15	300			
			1.9			13.5	260			
30-600	DN 50	DN 40	1.2	3	34	25	380	90	4	4,5
			1.5			22.5	350			
			1.9			20	290			
22-800	DN 65	DN 50	1.2	3	48	17	550	90	4	4,5
			1.5			13	450			
			1.9			10	400			
35-1000	DN 80	DN 50	1.2	3	54	26	550	90	5.5	4,5
			1.5			16	480			
			1.9			14	400			
26-1200	DN 80	DN 50	1.2	3	72	19	800	90	5.5	4,5
			1.5			16	650			
			1.9			12	550			
30-1300	DN 80	DN 50	1.2	3	78	25	950	90	7.5	4,5
			1.5			20	800			
			1.9			17	710			
40-1500	DN 80	DN 50	1.2	3	90	32	1100	90	11	4,5
			1.5			24	900			
			1.9			20	800			

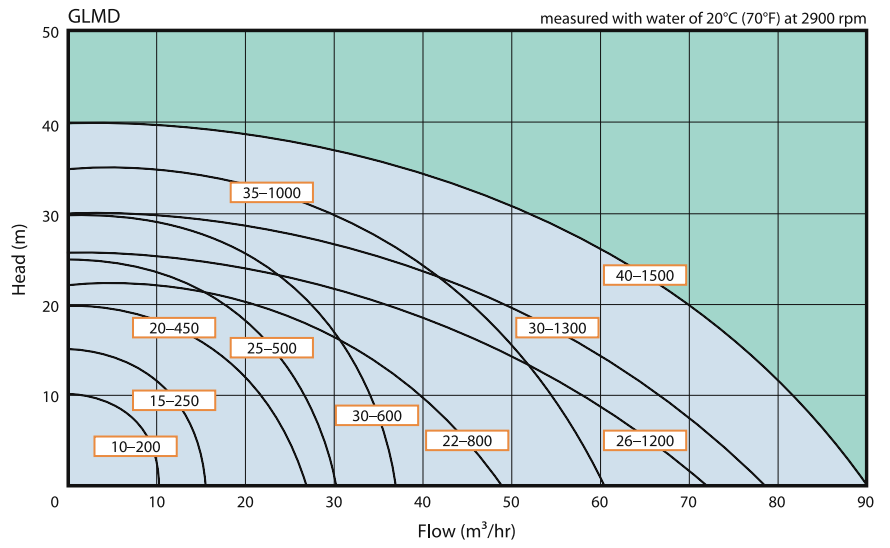

Type	A	B	C	D	E	F	G	H	I	J	K	L	M	N
10-200	80	240	95	146	110	155	4 X 14	125	88	234	15	115	122	R 45
15-250	93	285	111	250	130	195	4 X 14	150	104.5	260	15	135	140	R 55
20-450	77	320	106	275	140	200	4 X 14	165	87	291	15	155	140	R 62.5
25-500	77	320	106	275	140	200	4 X 14	165	87	291	15	155	140	R 62.5
30-600	77	320	106	275	140	200	4 x 14	165	87	312.5	15	155	140	R 62.5
22-800	110	350	130	305	210	260	4 x 14	185	110	349	20	175	150	R 72.5
35-1000	110	350	130	305	210	260	4 x 14	185	110	369	20	175	150	R 72.5
26-1200	155	385	193	320	220	280	4 x 14	200	118	378	18	175	185	R 80
30-1300	155	385	193	320	220	280	4 x 14	200	118	378	18	175	185	R 80
40-1500	155	385	193	320	300	350	4 x 14	200	118	409	20	200	185	R 80

	O	P	Q	R	S	T	U	V	W	X	Flange A	Flange B
10-200	R 43.5	19	51	114	102	19	R 43.5	R 45	125	417	DN 25	DN 25
15-250	R 52.5	19	57.5	118	123	19	R 52.5	R 55	150	475	DN 40	DN 40
20-450	R 60	19	65	138	133	19	R 52.5	R 55	150	529	DN 40	DN 50
25-500	R 60	19	65	138	133	19	R 52.5	R 55	150	556	DN 40	DN 50
30-600	R 60	19	65	160	138	19	R 52.5	R 55	150	602.5	DN 40	DN 50
22-800	R 70	19	62	160	138	19	R 60	R 62.5	165	639	DN 50	DN 65
35-1000	R 70	19	62	185	148	19	R 60	R 62.5	165	719	DN 50	DN 65
26-1200	R 75	19	0	185	148	M16	R 62.5		165	728	DN 50	DN 80
30-1300	R 75	19	0	185	148	M16	R 62.5		165	728	DN 50	DN 80
40-1500	R 75	19	0	185	235	M16	R 62.5		165	904	DN 50	DN 80

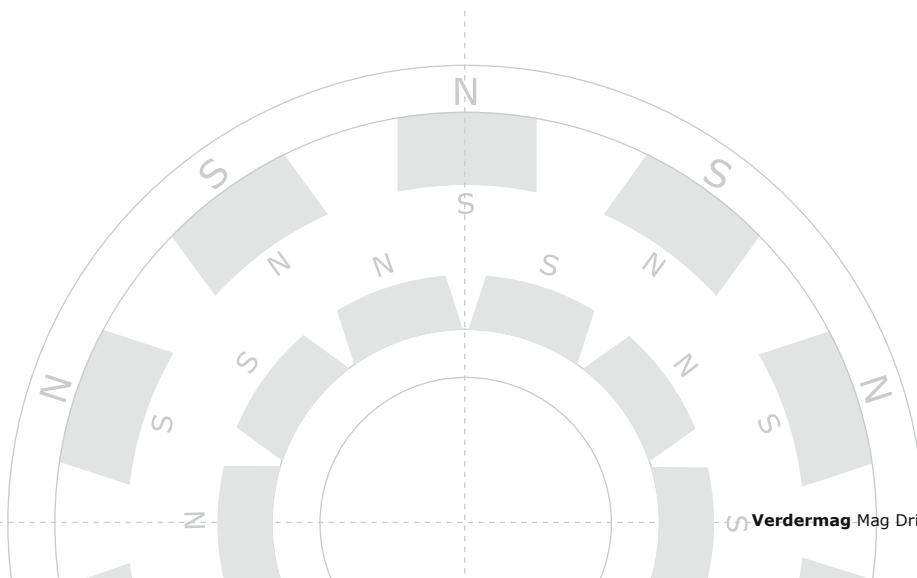

VERDERMAG TB, U and V&W SERIES

As a result of thorough research and cooperation with the best technical designers Verder can now present you the newest mag drive series, with thrust balancing (TB-series) and universal purpose pumps (U-series). Also available is the V&W series, based upon the TB series, vertical inline pumps with the same benefits and features as the TB series.

The patented Thrust Balancing Design eliminates axial thrust bearings and provides the basis for a controlled internal environment. This design minimizes the issue of secondary containment by providing secondary bearings.

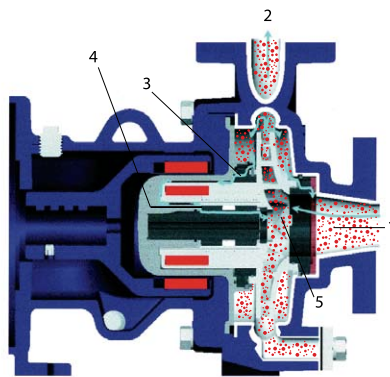

Working principle

The single, enclosed impeller/magnet assembly is free to rotate and slide on the central cantilevered shaft. The main flow of liquid enters the impeller (1) and is pressurized and then expelled into the volute (2) and out the discharge. A small portion of the flow passes behind the impeller and through the back wear ring clearance (3) and then into the balance chamber. This liquid then flows through, past the bushings (4) to exit at the valve (5). If the impeller moves forward, the valve is opened to a greater degree and the balance chamber pressure is reduced. This causes the impeller to react with a net force towards the motor. However, the valve is now closing and the balance chamber pressure increasing. This moves the impeller towards the suction. The net result is a very stable axial position for the impeller. There are no axial bearings and the radial bearings always operate in a pressurized fluid environment.

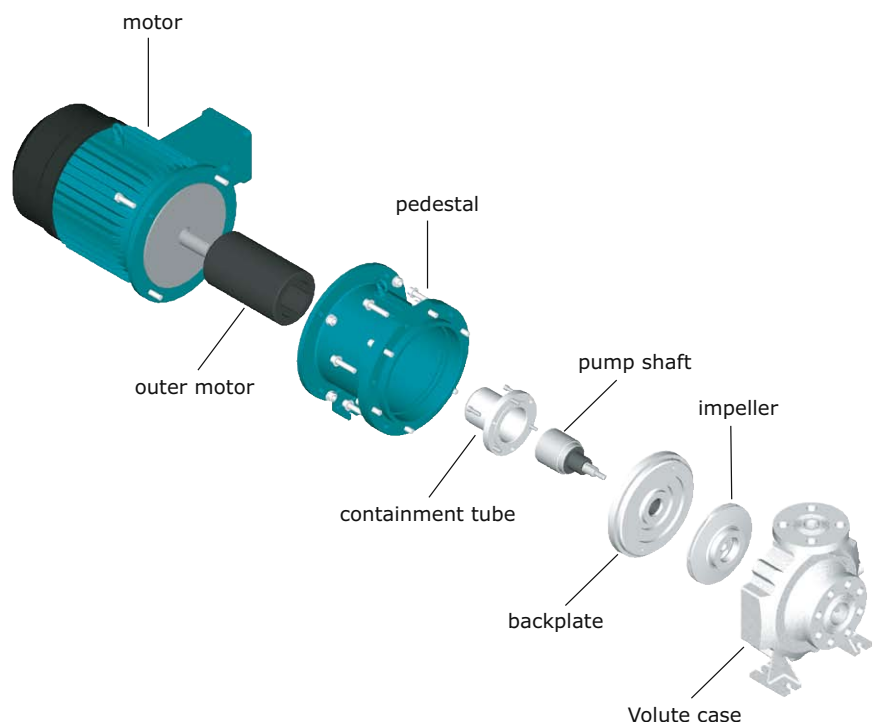

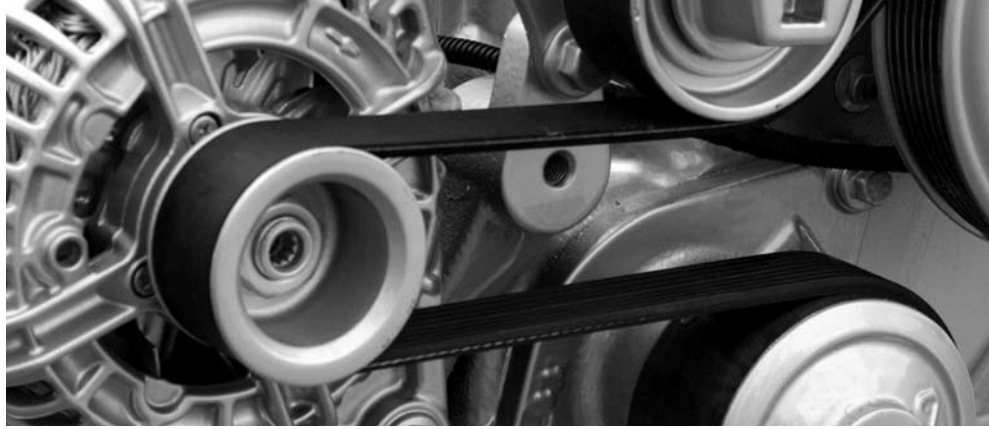

OVERVIEW OF PUMP MODELS

Model TB

Model TB offers with 3 impeller sizes and in total 14 suction/discharge configurations a tremendous flow range to meet with all your requirements. With SiC as standard material, and patented thrust balancing and wear rings that work as a secondary bearing, this pump is suitable for pumping solids in the liquid. This series is an advanced mag drive pump for all heavy duty pump applications for best economic prices.

Model U

Engineered with the same robust constructions as the TB model, these pumps are perfect for low flow chemical transfer, scrubber applications and high purity chemical services. Pure Teflon PFA or Carbon reinforced Tefzel combined with SiC or Carbon Graphite offer best universal chemical resistance in the dirtiest or most pure applications.

Models V&W

Models V and W are an extension for the TB model, with the same unique properties and features, but designed as an in-line pump.

Features and advantages

- Suitable for volatile liquids using non-metallic mag drive technology
- Thrust balanced impeller; no axial bearing problems during low suction operation even with severe cavitation or entrained air in the fluid
- Increased pump reliability and pump life because of balanced impeller
- Standard SiC replaceable wear parts
- Particles cannot enter containment shell of inner magnet gap
- NPSHr is equal to standard sealed pumps
- BEP's are equal to standard sealed pumps
- One bolt size only – simplifies maintenance
- Wear rings work as secondary bearing to protect impeller/inner magnet assembly
- Very good price-quality combination

Pumping Solids with models TB

The back wear rings filter the solids from the fluid, resulting in a clean, filtered liquid used for cooling and lubrication of the inner magnet, bearing and shaft. Max particle size = 3.2 mm.

Special features

Containment shell

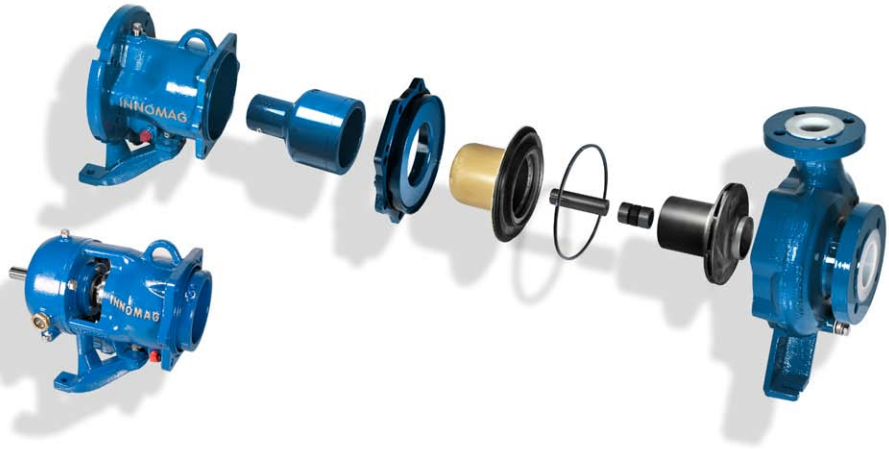

Features and advantages

- One piece molding of carbon fiber-reinforced ETFE or PFA
- Containment shell reinforced with a Aramid/Vinyl ester composite, burst pressure > 200 bar
- Reinforces shaft socket
- Front face houses stationary SiC wear ring
- Internal ribs limit swirl
- Optimum combination of pressure and shock resistance
- Able to handle any combination of radial loads
- No heat generation and max. possible efficiency
- Zero Eddy Current losses
- Fast ejection of fine particles from containment shell

Single piece impeller

- Molded one piece enclosed impeller made of carbon fiber-reinforced ETFE or PFA
- High strength neodymium iron boron magnet assembly
- Maximum size magnets in every impeller
- Double welded magnet assembly, preventing permeation
- High efficiency
- Fully open impeller eye
- Hermetically sealed from the environment
- Low NPSHr impeller geometry
- No shaft socket or support struts
- Radial bearings and trust control valve

Special materials selection

- A great pump needs great materials. Verdermag TB mag drive pumps have many specialty materials to create a marvelous pump
- Fluoroplastics
- For the ultimate in chemical and corrosion resistance Verder uses only the highest grade of fluoroplastic resins. ETFE, PTFE and PFA. All inside surfaces of TB pumps are made of fluoroplastics. This includes injection molded impellers and containment shells right down to rotationally molded pump lining



Composites

All Verdermag TB containment shells are made with Aramid fibers for the ultimate in burst resistance. Excellent water hammer resistant (ratings +200 bar).

Alpha sintered Silica Carbide

A grade of ceramics which is simply the best, chemically inert, extremely hard and wear resistant. Standard material for the shaft and bearings in TB pumps.

Custom accessories

- Steam heat jackets
- Low flow models to save energy
- Direct mount engine driven options for tanker trucks and remote locations



	TB	U	V, W
Flow range	0.3 – 300 m ³ /h	0.1 – 85 m ³ /h	0.2 – 37 m ³ /h
Head	up to 110 m	up to 40 m	up to 65 m
Temperature	-29 °C - +120 °C	-29 °C - +120 °C	-29 °C - +120 °C
Operating pressure	21 bar	21 bar	21 bar
Power supply	up to 45 kW	up to 7.5 kW	up to 18.5 kW

Applications

- Chemical processing
- Metal plating
- Parts washing
- Circuit boards
- Photo processing
- Pharmaceuticals
- Food processing
- Wet scrubbers
- Semi conductor

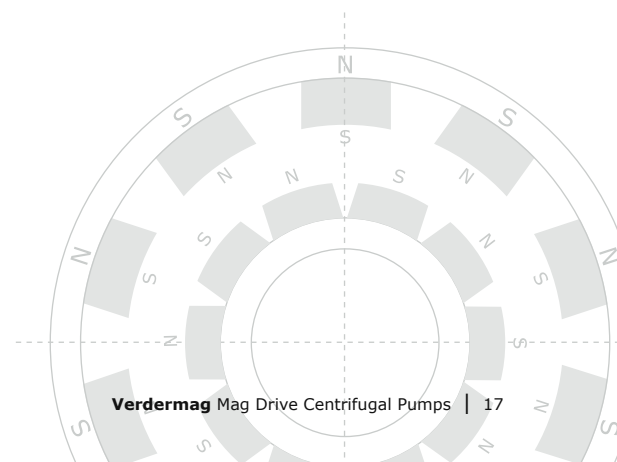

VERDERMAG MODEL TB

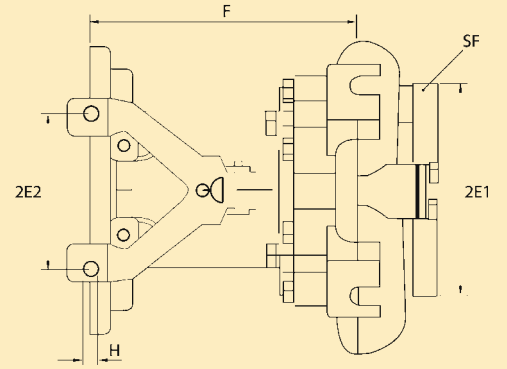

Type	Connections		Flow - m ³ /h		BEP		Temp. °C	Motor Max. kW
	Suction	Discharge	Min.	Max.	H(m)	Q(L/min)		
TB 32-160	DN 50	DN 32	0.2	33	33	370	121	8.7
TB 50-160	DN 65	DN 50	0.2	56	30	580	121	8.7
TB 32-200	DN 50	DN 32	1.1	37	57	420	121	18.5
TB 40-200	DN 65	DN 40	1.1	60	60	666	121	18.5
TB 65-200	DN 100	DN 65	1.1	155	45	1730	121	45
TB A1516	DN 50	DN 32	0.2	33	33	370	121	8.7
TB A1516LF	DN 50	DN 32	0.2	6	4	67	121	8.7
TB A3156	DN 65	DN 40	0.2	56	30	580	121	8.7
TB A326	DN 80	DN 50	0.2	56	30	580	121	8.7
TB B1518	DN 50	DN 32	1.1	37	57	420	121	18.5
TB B1518LF	DN 50	DN 32	1.1	7	50	92	121	18.5
TB B326	DN 80	DN 50	1.1	76	42	633	121	18.5
TB B3158	DN 65	DN 40	1.1	60	60	666	121	18.5
TB B326	DN 80	DN 50	1.1	86	36	833	121	18.5
TB B436	DN 100	DN 80	1.1	130	34	1500	121	18.5
TB C328	DN 80	DN 50	1.1	88	56	1000	121	45
TB C438	DN 100	DN 80	1.1	155	45	1730	121	45
TB C648	DN 150	DN 100	3.4	283	46	3000	121	45
TB C2110	DN 50	DN 32	3.4	42	95	500	121	45
TB C2110LF	DN 50	DN 32	3.4	8	70	120	121	45
TB C31510	DN 80	DN 40	3.4	60	95	666	121	45
TB C3210	DN 80	DN 50	3.4	108	90	1500	121	45
TB C4310	DN 100	DN 80	3.4	132	90	1833	121	45
TB C4310H	DN 100	DN 80	3.4	196	20	2166	121	45
TB C6410H	DN 150	DN 100	3.4	283	18	3333	121	45

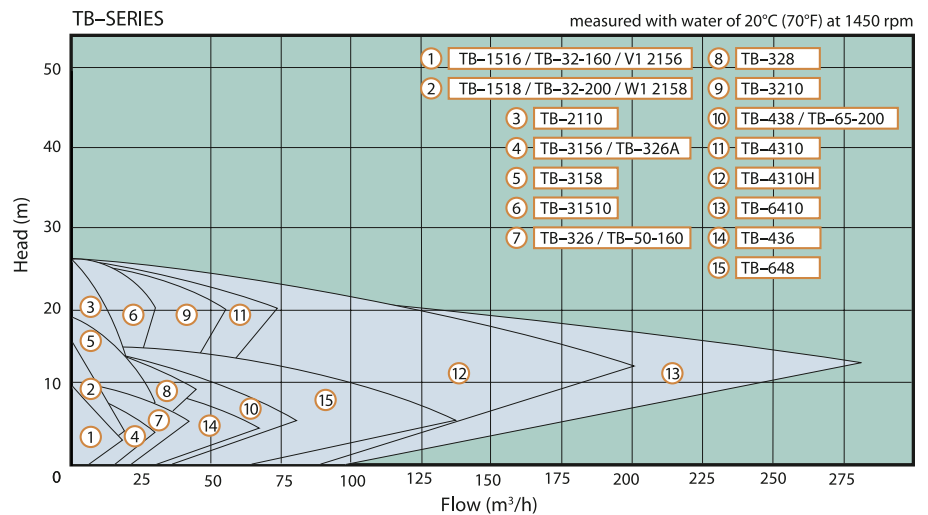

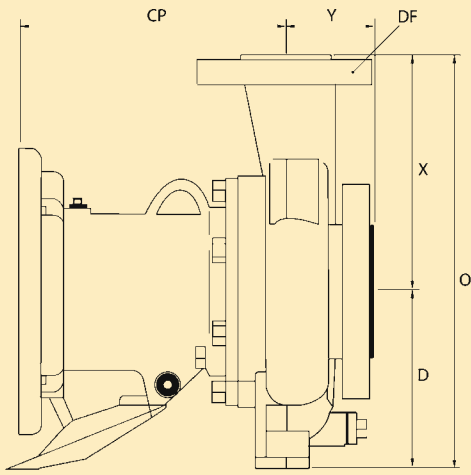

Pump size ISO	D	2 E 1	2 E 2	F	H	O	X	Y	CP	SF(DN)	DF(DN)
TB 32-160	133	190	110	186	16	292	160	132	221	50	32
TB 32-200	160	190	110	252	16	340	180	80	312	50	32
TB 50-160	132	190	110	186	16	292	160	80	222	65	50
TB 40-200	160	212	110	284	16	340	180	100	312	65	40
TB 65-200	180	250	110	254	16	405	225	100	312	100	65

ANSI											
TB 1516	133	152	0	184	16	298	165	102	221	40	25
TB 1516 LF	133	152	0	184	16	298	165	102	221	40	25
TB 1518	133	152	0	184	16	298	165	102	221	80	40
TB 1518 LF	133	152	0	184	16	298	165	102	221	80	40
TB 326	133	152	0	184	16	298	165	102	287	80	50
TB 3156	133	152	0	184	16	298	165	102	221	80	40
TB 436	210	248	184	318	16	425	216	102	287	100	80
TB 3158	210	248	184	318	16	425	216	102	287	80	40
TB 328	210	248	184	318	16	451	241	102	287	80	50
TB 438	210	248	184	318	16	489	279	102	287	100	80
TB 2110	210	248	184	318	16	425	216	102	287	50	25
TB 2110 LF	210	248	184	318	16	425	216	102	287	50	25
TB 31510	210	248	184	318	16	425	216	102	287	80	40
TB 3210	210	248	184	318	16	451	241	102	287	80	50
TB 4310	210	248	184	318	16	489	279	102	287	100	80
TB 4310H	210	248	184	318	16	489	279	102	287	100	80
TB 648	254	248	184	318	16	597	343	102	287	150	100
TB 6410	254	248	184	318	16	597	343	102	287	150	100

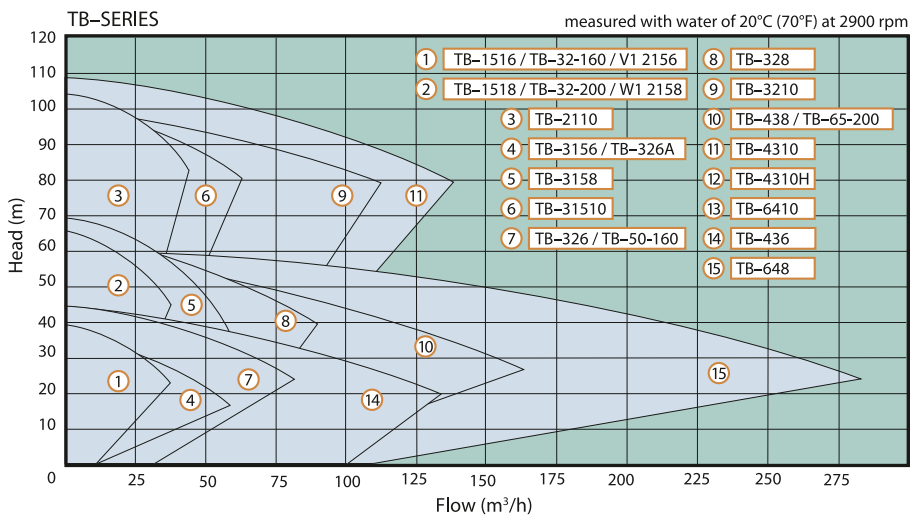

VERDERMAG MODEL U

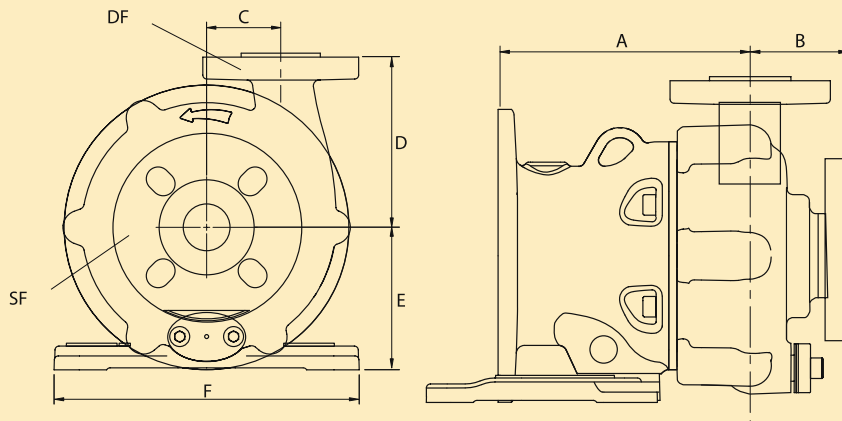

Type	A	B	C	D	E	F	SF(DN)	DF(DN)
U25-125	170	80	60	140	114	245	40	25
U40-160	170	87	65	140	155	245	50	40
U65-160	170	100	0	180	155	245	80	65
U50-160	170	80	0	160	155	245	65	50

Type	Connections		Flow - m ³ /h		BEP		Temp. °C	Motor Max. kW
	Suction	Discharge	Min.	Max.	H(m)	Q(L/min)		
U25-125	DN 40	DN 25	0.2	22	25	220	121	7.5
U25-125LF	DN 40	DN 25	0.2	5	25	75	121	7.5
U40-160	DN 50	DN 40	0.2	32	31	350	121	7.5
U50-160	DN65	DN 50	0.2	52	26	550	121	6.2
U65-160	DN 80	DN 65	0.2	83	6	1000	121	3

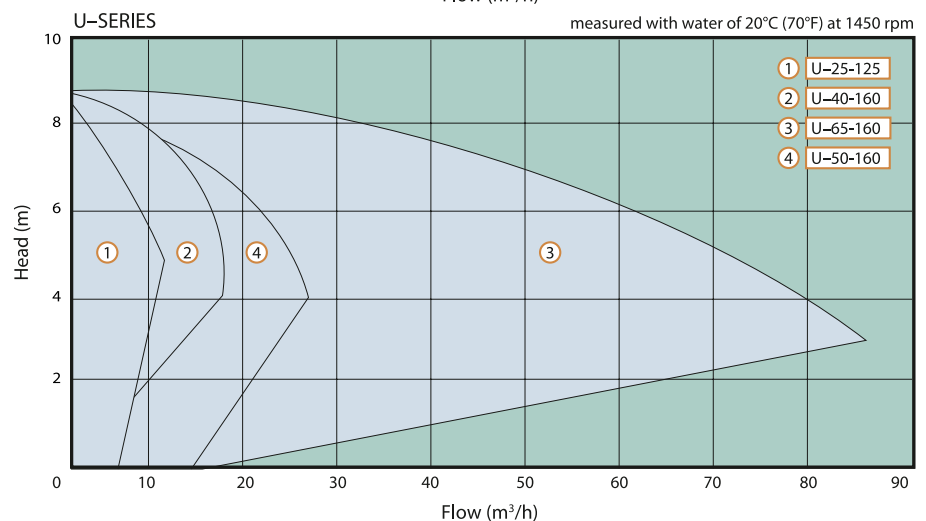
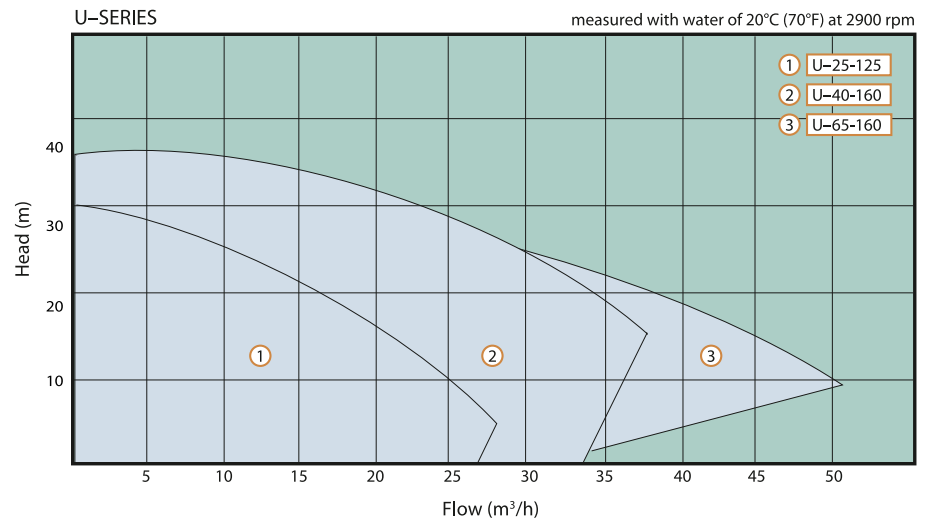

VERDERMAG MODEL V&W

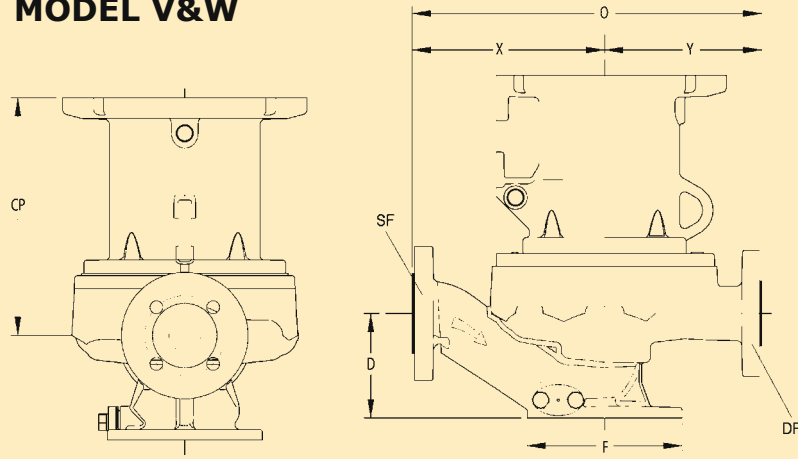

Type	D	F Ø	O	X	Y	CP	SF(DN)	DF(DN)
V1 - 2 x 1.5 x 6	114	152	380	165	215	213	50	32
W1 - 2 x 1.5 x 8	129	152	431	194	237	284	50	32

Type	Connections		Flow - m ³ /h		BEP		Temp. °C	Motor Max. kW
	Suction	Discharge	Min.	Max.	H(m)	Q(L/min)		
V1 - 2 x 1.5 x 6	DN 50	DN 32	0.2	37	35	420	121	8.7
W1 - 2 x 1.5 x 8	DN 50	DN 32	1.1	33	50	450	121	18.5

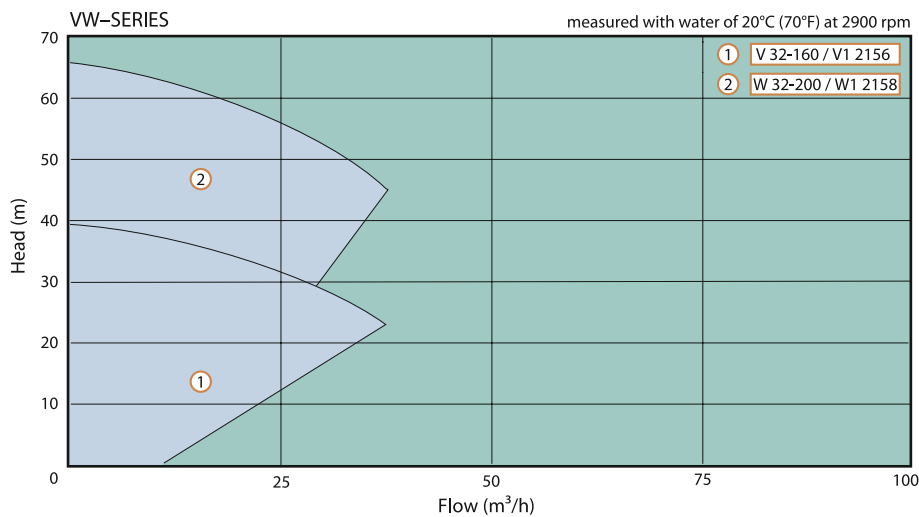
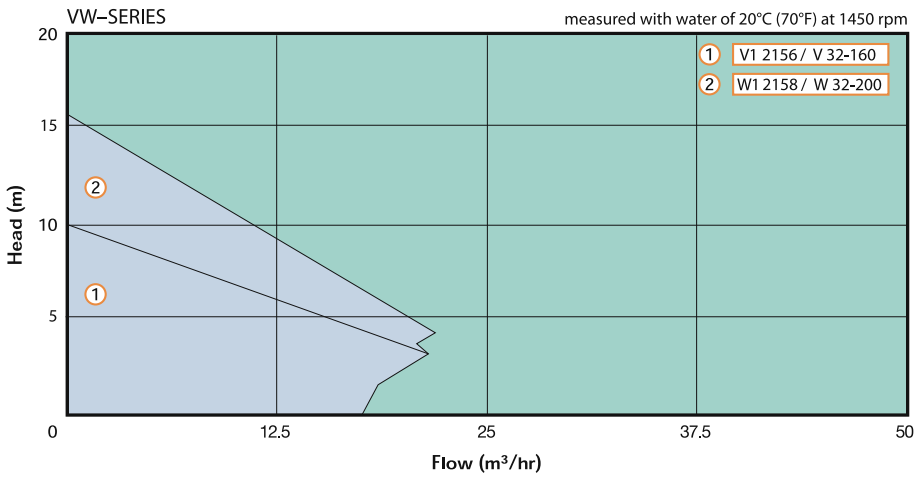

VERDERMAG GPSP SERIES

In cooperation with worlds' best technical designers Verder now can present you the fastest suction with the most advanced self priming pump technology. Where space savings are important or when you don't have a flooded suction, the Verdermag GPSP offer solutions in a large variety of applications. Furthermore the Verdermag GPSP series have the fastest suction in the world (5.5 m/ 2 min.)

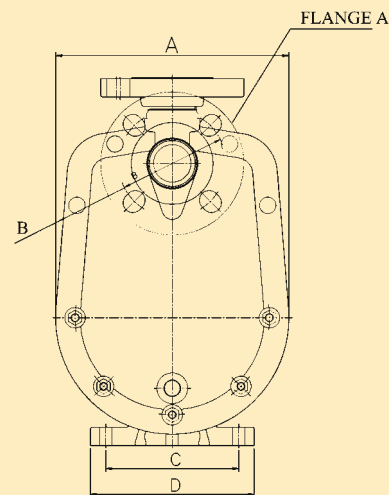

Type	A	B	C	D	E	F	G	H	I	J	K	L	M
GPSP 251GV(F) CD5-G	196	87	130	160	325	255	70	115	167	275	40	130	25
GPSP 402GV(F) CD5-G	228	105	130	160	360	276	84	125	190	305	40	130	25
GPSP 503GV(F) CD5-G	248	120	208	260	389	296	93	135	206	309	23	200	27
GPSP 505GV(F) CD5-G	248	120	230	260	389	296	93	135	206	309	27	261	27

Models

The GPSP series self priming mag drive pump is a high quality mag drive centrifugal pump with best efficiency and fastest working duty points. Model GV is constructed of polypropylene (housing material) whilst model GV(F) is constructed of E-TFE.

Material choice on bushing and O-ring is carbon/FPM, ceramics/FPM or PTFE/FPM to provide utmost application possibility.

Features and advantages

- Worlds' fastest suction
- Air lock / cavitation free construction
- Prevented and resistant to dry running
- Patented valveless mechanism
- Patented heat resistant bushing
- Compact, simple construction
- Easy replacement of wear parts

Technical details

GPSP	
Flow range	max. 440 l/min
Head	up to 26.5 m
Temperature	PP up to 70 °C, ETFE up to 80 °C
Power supply	up to 4 kW

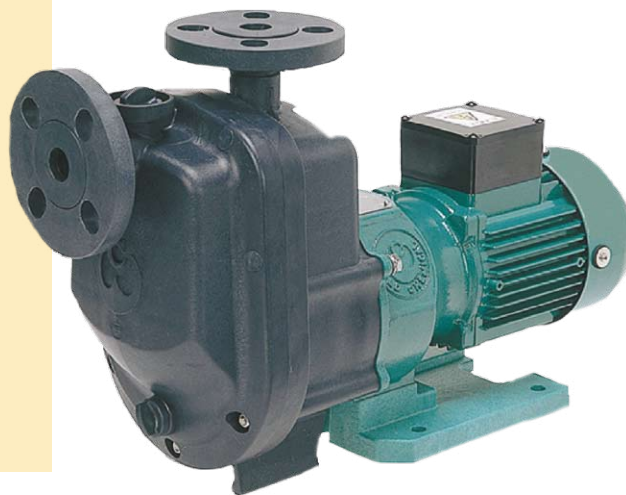
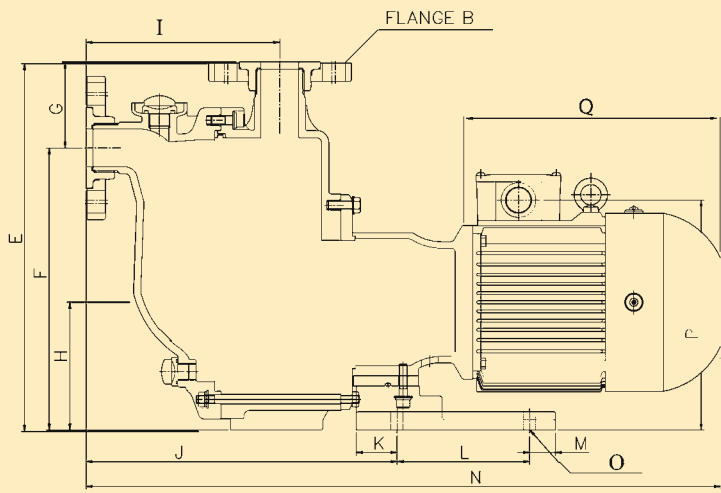

N	O	P	Q	Flange A	Flange B	kW
562	4x12	207	183	DN 25	DN 25	0,75
622	4x12	225	215	DN 40	DN 40	1,5
643	4x14	235	265	DN 50	DN 50	2,2
713	4x14	240	315	DN 50	DN 50	4

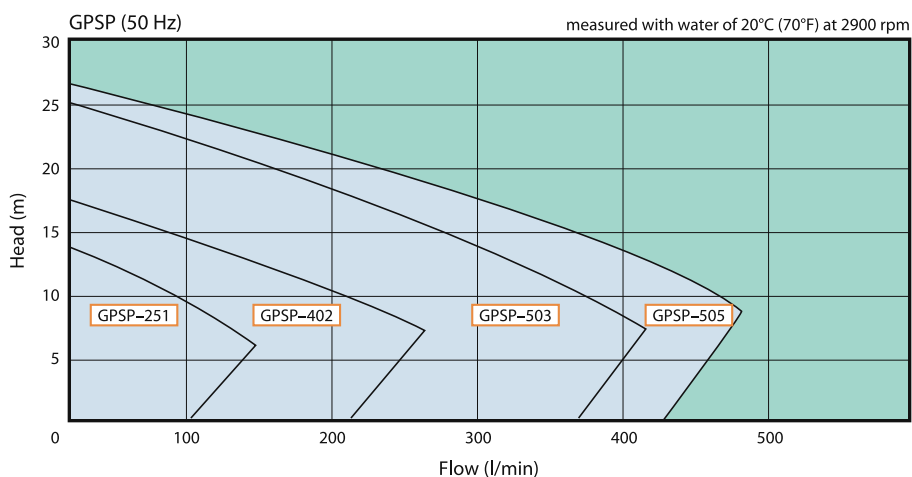

Applications

- Chemical industry
- Plating
- Etching
- Sea water
- Clean room application
- Circuit boards
- Photo processing
- Pharmaceuticals
- Food processing
- Wet scrubbers
- Semi Conductor

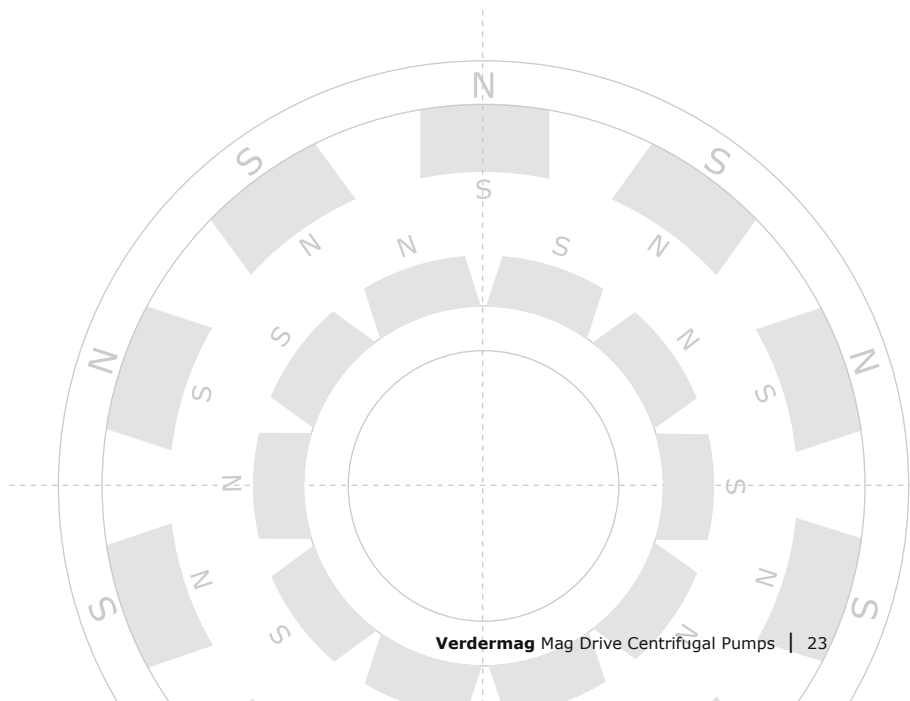

VERDERMAG GLOBAL SERIES

A combination of the latest materials and engineering practices, coupled with Verder's 50 years' experience in manufacturing synchronous magnet-driven seal-less pumps, has created a flexible range of pumps ideally suited to modern requirements. Tried and trusted designs have been updated to allow modular construction, with many interchangeable components. The pumps can be assembled from stock components to give quick response times, whilst spares requirements are kept to an absolute minimum.

The Global pump utilises the differential pressure generated by the pumping action to create a flow around the bearings and magnets. The pumped liquid acts as a cooling medium to dissipate the heat generated from Eddy Currents as the magnets pass around the containment shell. It is also used to lubricate the hydrodynamic bearing sets, with flow from the front bearing passing through the balance holes of the impeller and flow around the rear bearing re-entering the low pressure suction area of the volute.

Specialist in-house engineering capabilities allow Global to offer a wide range custom made products, covering extended flow ranges, temperatures and pumps required for use in high system pressure applications.

Features and advantages

- Simple by design - fewer parts are used in the whole pump than most conventional seal cartridges ensuring easy maintenance and assembly
- Bearings - top grade silica free silicon carbide - fitted as standard for its chemical resistance to most reagents. An added benefit is its exceptional hard wearing capabilities.
Only 4 bearing sizes cover the entire Global range
- Press fit bearing design - bearings are seated on static O-rings, to absorb small movements and temperature shocks, ensuring consistently high performance and easy fitting
- O-rings – gaskets are specially chosen to suit the customer's specific requirements. High temperature perfluoro-elastomers o-rings, such as Kalrez, Perlast or Chemraz are available; these extend the pump capability up to +250 °C
- In-house engineering capability allows for specialist pumps to be developed for specific applications
- The Verdermag Global series can also be ATEX marked, making them ideal for the petrochemical industry
- Top grade rare earth samarium cobalt magnets are fitted as standard on all pumps making high temperature applications easy



OVERVIEW OF PUMP MODELS

Style 1

A range of close coupled pumps covering low flow and head requirements, with power outputs from 0.55 – 4.0 kW.

MII

This range is manufactured according to ISO 2858 at the hydraulic end with close-coupled drive connection, covering a wide range of flow and heads, with power outputs from 3.0 – 30 kW.

High System Pressure Pumps (HSP)

A range of pumps for system pressures of up to 200bar, with power outputs from 0.75 – 11 kW.

Applications

- Chemical processing
- Tank farms
- Re-circulation duties
- Thermal oil heat transfer
- Sampling systems
- Pharmaceuticals
- Special chemicals
- Oil and offshore

In addition custom made pumps are manufactured in exotic alloys, such as, Hastelloy, Inconel, Titanium or Duplex.

Technical information

	Style 1	M II	HSP
Flow range	1-25 m ³ /h	5-150 m ³ /h	1-70 m ³ /h
Head	up to 40 m	up to 100 m	up to 100 m
Temperature range	-20 to 200 °C**	-20 to 200 °C**	-20 to 200 °C**
Operating pressure	16 bar*	16 bar*	up to 200 bar
Test pressure	24 bar	24 bar	up to 300 bar
Power supply	4 kW	30 kW	11 kW

* Engineered products available outside these ranges. Pump will be de-rated for high temperature considerations applications in accordance with appropriate pressure vessel and flange standards

** Down to -100C and up to 250 °C with correct O-ring/material options

VERDERMAG MODEL STYLE 1

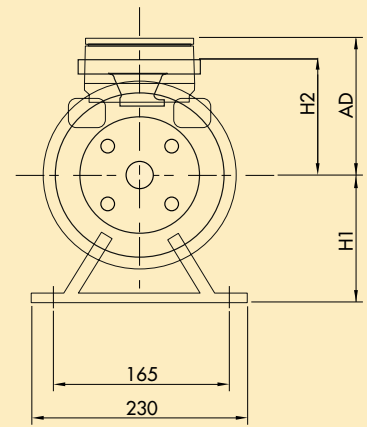

Model Style 1

This range of pumps is suitable for lower duties than covered by the ISO 2858 (MII) pumps.

They offer a low-cost option for low flow and head duties and are available from stock.

Features and advantages

- Hydraulic pump end with standard casing and fabricated casing bowls with centerline discharge
- Single bearing design for increased reliability
- High level of interchangeability for spare parts
- Optional: Universal, PN16 or ANSI 150.lb. flanges
- Close coupled motor fitment, no need for re-alignment on commissioning and after servicing

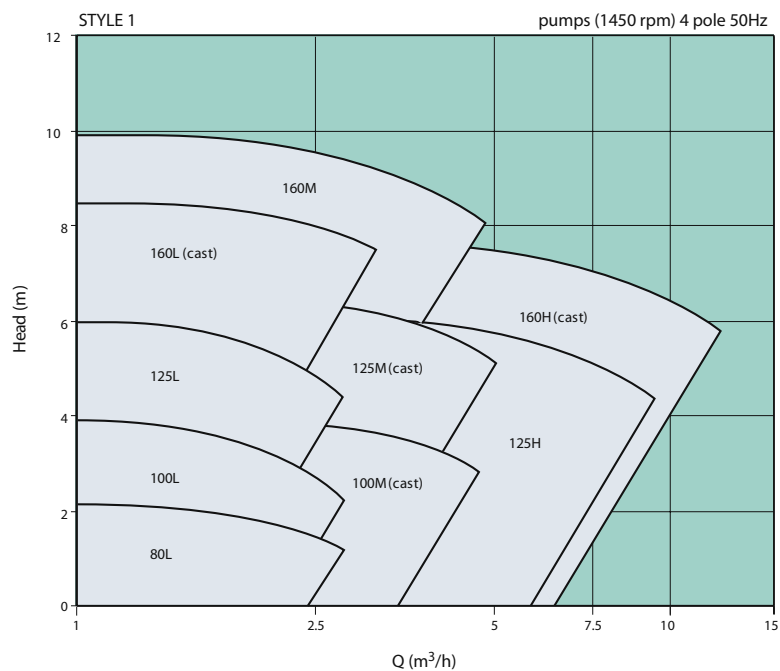

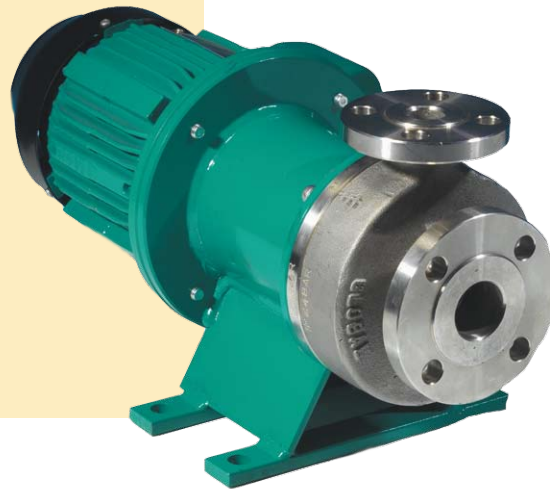
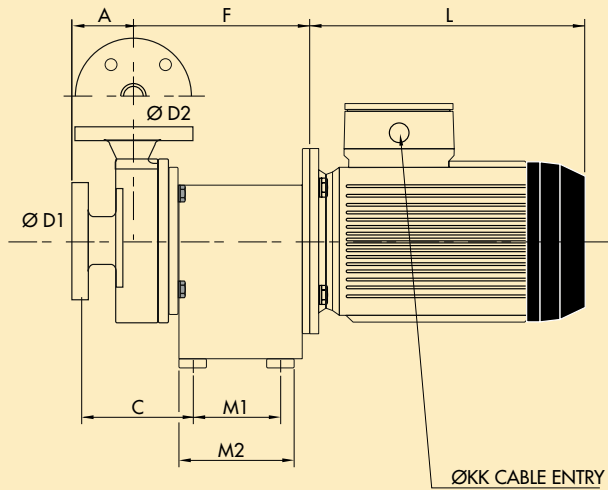

Type	D1	D2	A	C	F	H1	H2	M1	M2
PC 100L	25	25	62	118	184	139	115	93	123
PC 100M	40	25	62	118	184	139	115	93	123
PC 125H	50	40	82	136	186/201*	139	142	123/145*	93/115*
PC 125L	25	25	62	118	186/201*	139	125	123/145*	93/115*
PC 125M	40	25	62	120	186/201*	139	125	123/145*	93/115*
PC 160H	50	40	80	138	158/169*	139	160	93	114
PC 160L	25	25	65	123	158/169*	139	150	93	114
PC 160M	40	25	68	126	158/169*	139	150	93	114

L, AD, KK depending on motor frame size and motor brand.

* means depending on the installed motor frame size

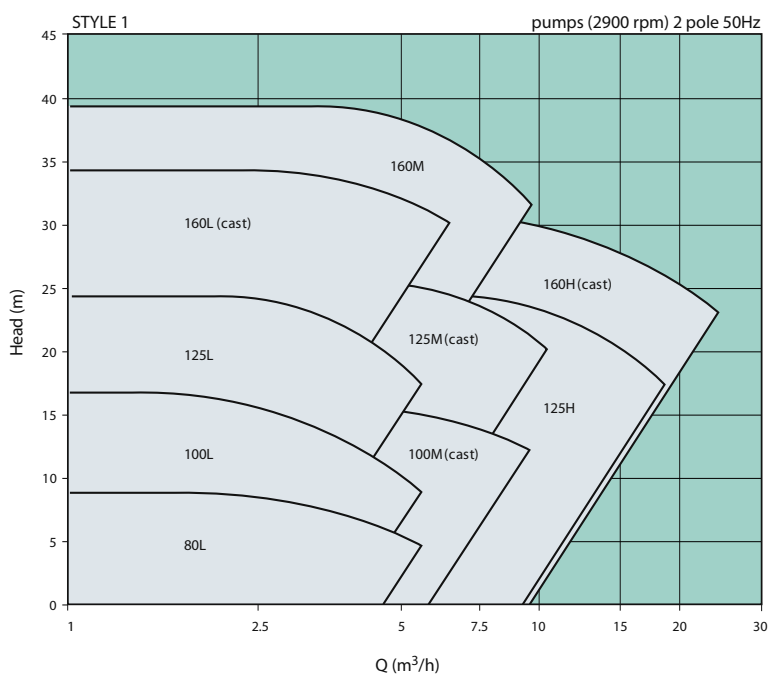

VERDERMAG MODEL MII

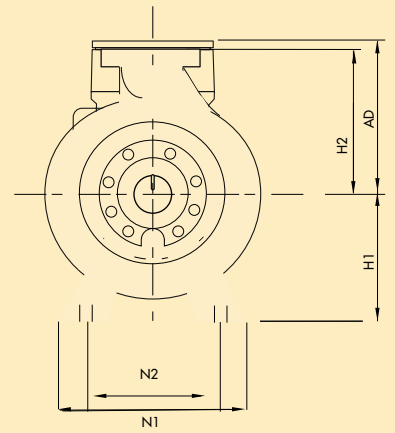

Model MII

This Range of ISO 2858 standard pumps, offers a medium to high flow and head duties. Many of the medium flow and heavy duty pumps are available to assemble from stock components.

Features and advantages

- According to ISO 2858
- Twin bearing design for superior operation
- Modular design: high interchangeability of spare parts
- Alternative joints and elastomers are available
- Casing can be supplied with PN16
- Close coupled motor fitment, automatically aligns rotating parts and eliminates the need for re-alignment on commissioning and after servicing
- Thermocouple probe connection to back plate to permit bearing temperature to be monitored
- Heating / cooling jackets to back plate and/or casing

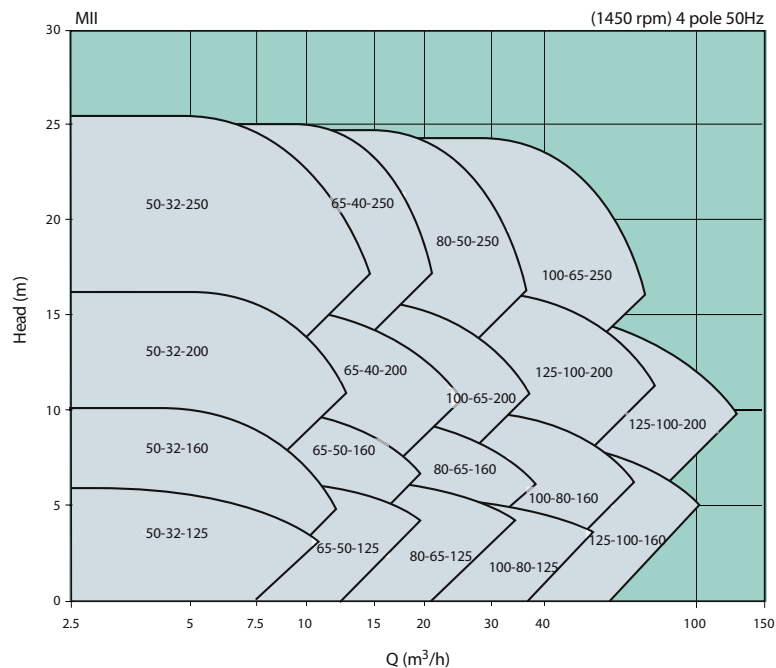

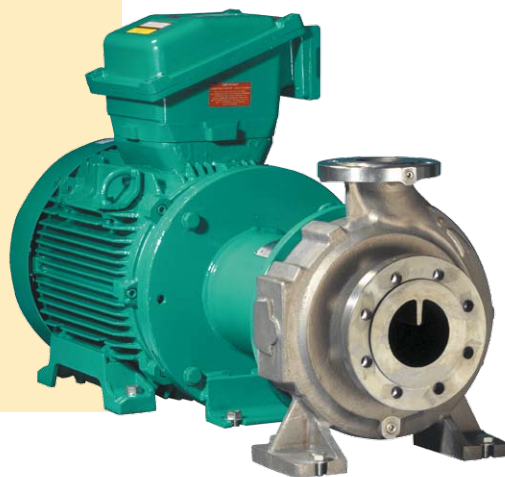
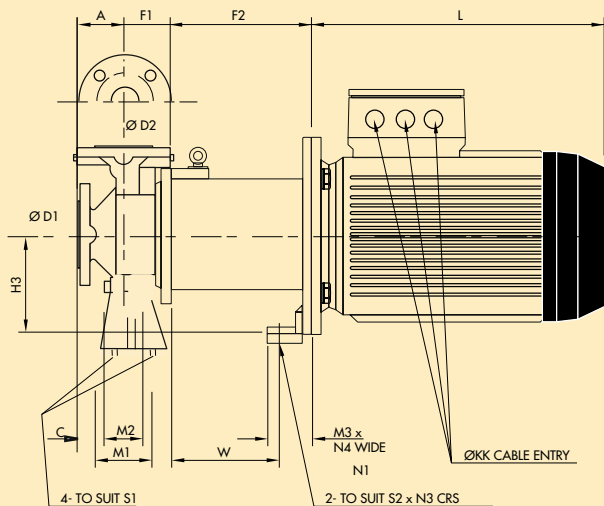

Type	D1	D2	A	C	F1	H1	H2	M1	M2	N1	N2	S1
100-65-200	100	65	100	52.5	97.5	180	225	125	95	320	250	M12
100-65-250	100	65	125	65	92.5	200	250	160	120	360	280	M12
100-80-125	100	80	100	52.5	73.5	160	180	125	95	280	212	M12
100-80-160	100	80	100	52.5	86	160	200	125	95	280	212	M12
125-100-160	125	100	125	65	86	200	250	160	120	360	280	M16
125-100-200	125	100	125	65	98.5	200	280	160	120	360	280	M16
50-32-125	50	32	80	45	73.5	112	140	100	70	190	140	M12
50-32-160	50	32	80	45	71.5	132	160	100	70	240	190	M12
50-32-200	50	32	80	45	89.5	160	180	100	70	240	190	M12
50-32-250	50	32	100	52.5	92.5	180	225	125	95	320	250	M12
65-40-200	65	40	100	65	89.5	160	180	100	70	265	212	M12
65-40-250	65	40	100	52.5	92.5	180	225	125	95	320	250	M12
65-50-125	65	50	80	45	73.5	112	140	100	70	210	160	M12
65-50-160	65	50	80	45	77	132	160	100	70	240	190	M12
80-50-200	80	50	100	65	89.5	160	200	100	70	265	212	M12
80-50-250	80	50	125	77.5	92.5	180	225	125	95	320	250	M12
80-65-125	80	65	100	65	73.5	132	160	100	70	240	190	M12
80-65-160	80	65	100	65	77	160	180	100	70	265	212	M12

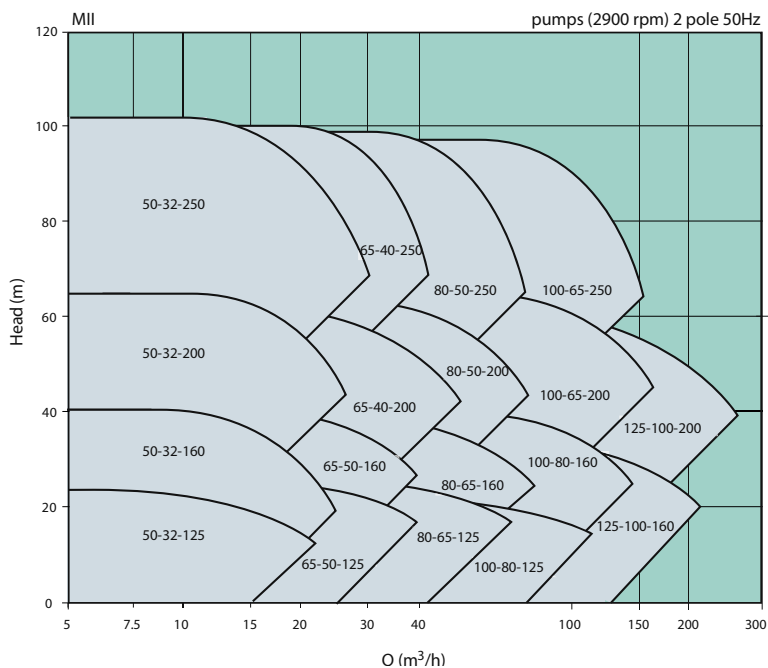

Drive Size	F2	H3	M3	S2	W
C3-112	171	132	65	M12	124
C3-132	191	160	65	M12	124
C6-132	224	160	80	M16	164
C6-180	254	180	80	M16	164
D6-180	254	180	80	M16	164
E6-180	254	180	80	M16	164
E6-200	254	210	80	M16	164
E9-200	325	210	100	M20	265
E9-225	325	250	100	M20	265
E9-280	355	280	100	M20	265

L, AD and KK depending on motor frame size.

VERDERMAG MODEL HSP

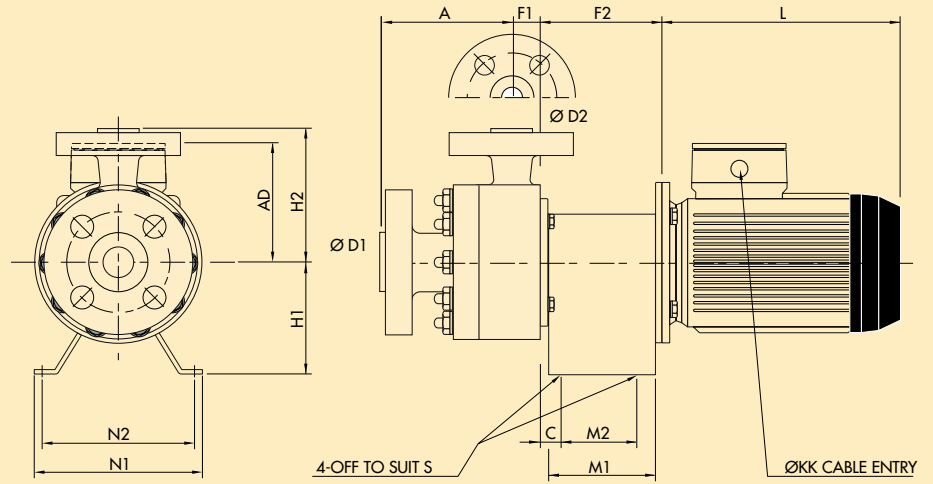

Drive Size	C	F2	H1	M1	M2	N1	N2	S
B1-080	24	150	139	130	93	230	165	M12
B3-090	24	150	139	130	93	230	165	M12
B3-11	24	165	139	145	115	230	165	M12
C3-11	13	180	180	180	130	245	195	M12
C3-13	13	200	180	180	130	245	195	M12
C6-13	33	240	180	220	170	245	195	M12
C6-180	33	270	180	220	170	245	195	M12

L, AD, KK are depending on motor frame size and motor brand.

Model HSP

The HSP range of pumps excels in areas where leaks are unacceptable. These pumps are particularly effective in applications where chemicals are pumped at high pressures.

Features and advantages

- Hydraulic pump end with standard casing and fabricated casing bowls with centerline discharge
- Single bearing design for increased reliability
- High level of interchangeability for spare parts
- Customer requirements for material, testing or coatings

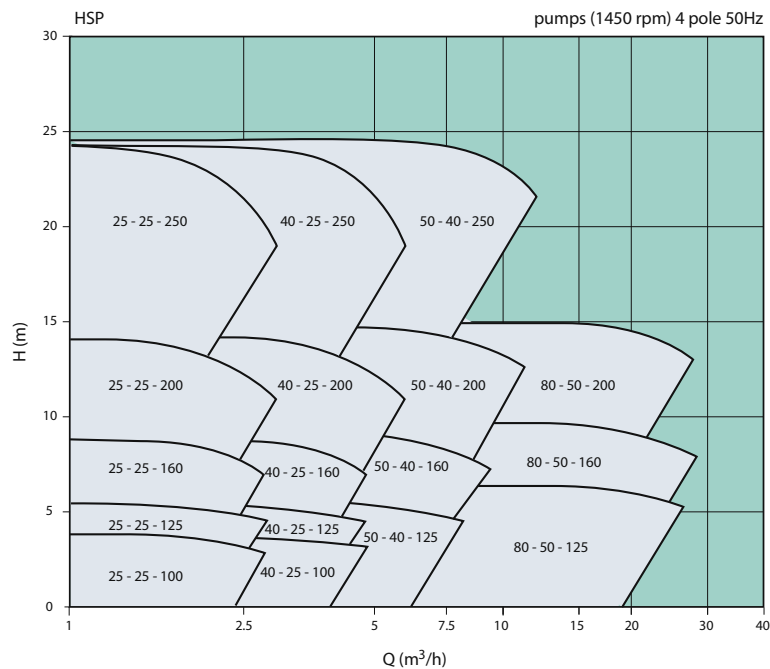

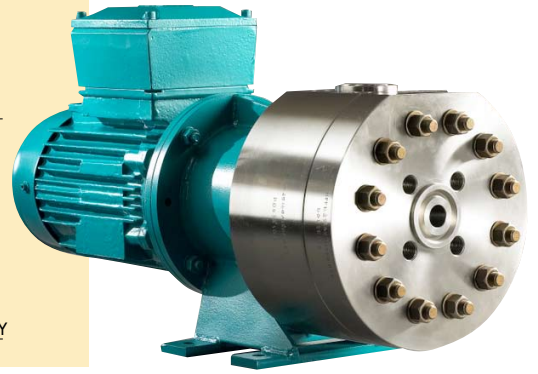
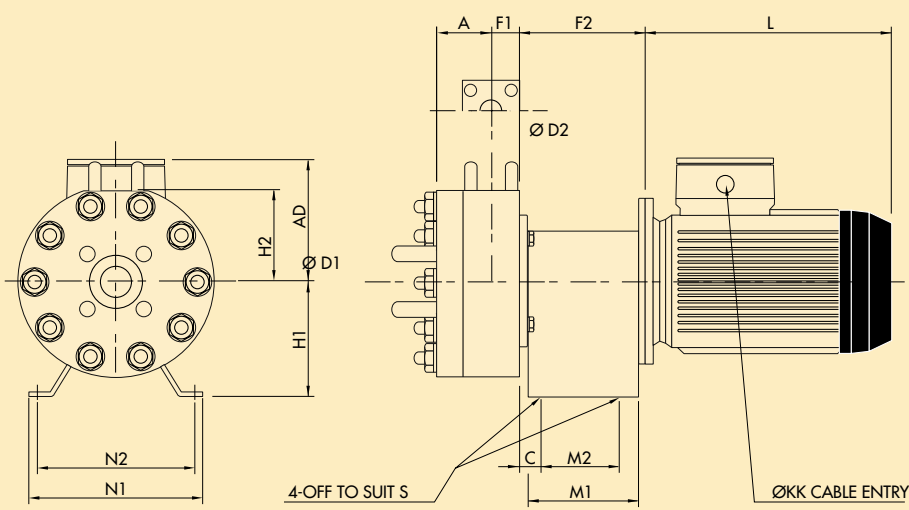

Type	D1	D2	A		F1	H2	
			Flanged version	Studded version		Flanged version	Studded version
25-25-100	25	25	165	110	34	175	110
25-25-125	25	25	165	110	34	187	110
25-25-160	25	25	170	110	64	206	135
25-25-200	25	25	170	110	64	230	165
25-25-250	25	25		110	64		180
40-25-100	40	25	165	110	34	175	110
40-25-125	40	25	165	110	34	187	110
40-25-160	40	25	170	110	64	206	135
40-25-200	40	25	170	110	64	230	165
40-25-250	41	26		110	64		180
50-40-125	50	40	165	110	34	187	110
50-40-160	50	40	170	110	64	206	135
50-40-200	50	40	170	110	64	230	165
50-40-250	50	40		110	64		180
80-50-125	80	50	200		38	206	
80-50-160	80	50	205		68	225	
80-50-200	80	50	205		68	249	

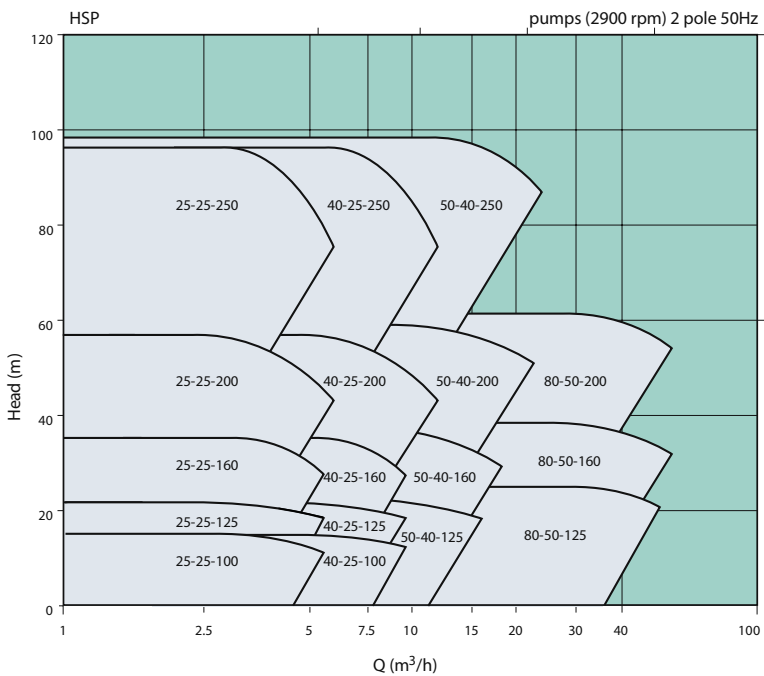

Applications

Agriculture

Fertilizer

Ammonia manufacturing

DSIA (disodium)
Hydrochloric acid 33%

Animal Nutrition

Ferric sulfate 10%

Automotive

Cooling

Battery manufacturing

Sulfuric acid

Beverage

Cleaning liquid
Brandy

Brewery

Cleaning liquid; water treatment

Bromine manufacturing

Bromine solutions

Chemical industry

Acrylic acid
Acrylamide
Aluminum chloride, 50%
Bleach gel
Chrome solution
Ferric chloride
Glycol, 30%
Hydrochloric acid, 35%
Hydrofluoric acid 50%
Hydrogen sulfide, 85%
Sodium hydroxide, 50%
Sulfuric acid, 98%
Titanium oxichloride slurry
Chemical transport
Ammonia
Salty acids 31%
Water with 20 % NaOH
Phosphate
Salt sole
Water + chemicals
Hydrobromic/sulfuric acid
Sodium hypochlorite 10%
Chrome manufacturing
Chrome solution

Clean rooms

Waste water

Cleaning

Fatty acid (hot)
Pigment
Sodium hypochlorite
Sodium hydroxide, 50%

Corn Starch industry

Hydrochloric acid 35%
Sodium hydroxide 50%
Sodium metabisulfite

Corn Sweetening

Sodium hypochlorite

Cosmetics

Solvents

Electronics industry

Plating, etching
Ferric chloride
Hydrochloric acid 37%
Sodium hydroxide 50%
MEK
Ethanol/Methano

Environmental industry

Caustic
Acids
VOC contaminants

Fine chemicals

Sulfuric acid 15%
High purity chemicals
Solvents

Food industry

Cleaning liquid for process
equipment

Galvanic industry

Plating, etching, filtration

Grain manufacturing

Hydrochloric acid 35%

High purity water treatment

Hydrogen peroxide, 10%

Latex production

Orto-di-chloro
Benzen (ODCB)
Toluen-di-isocianaat (TDI)

Materials supplying

Chlorinated organics

Metal

Pickling

Mining (Uranium)

Brine with uranium solids
H₂O, soda ash, HCl

Municipalities

Acids
Caustic

Nuclear power

Acids and caustics

Packaging industry

VOC

Paint and Lacquer

Paint
Solvents

Paint industry

Sulfuric acid, 93%
Dilute sulfuric acid
Hydrochloric acid

Paper mill

Aluminum chloride
Aqueous sodium bisulphate

Pet food

Acids and caustics

Petrochemical industry

Crude oil

Pharmaceutical vaccines

Sodium hydroxide 50%

Pharmaceutical industry

Caustic soda
Hot oil, solvents

Photo industry

Sulfuric acid, 35%
Developer

Plastics industry

Bleach solution
Sulfuric acid, 93%

Plating industry

Bromic acid
Sulfuric acid, 10%

Printing industry

Cooling
Solvents

Pulp and paper

White liquor and bleach

Rail car unloading

Monochloroacetic acid
Acids and caustics

Refinery

Sulfuric acid, 98%
Oil, solvents

Road tanker trucks

Acids and caustics

Semi-conductor industry

Cupric chloride
High purity chemicals

Phosforie Acid

Sulfuric Acid

Solvents manufacturing

Hydrochloric acid 30%
Solvents

Steel industry

Hydro chloric acid
Pickling
Sulfuric acid

Sterilizing

Sulfuric acid glycol trace ethylene
oxide
Cleaning liquid

Tank unloading

Sulfuric acid, 85%
Sulfuric acid, 93-98%
Acids and caustics

Utility

Sulfuric acid, 93%

Vaccines manufacturing

Methallyl chloride 100%

Washing streets

Soap solutions

Waste treatment

Acids

Water and sewage treatment

Acids
Caustic soda
Hydro chloric acid

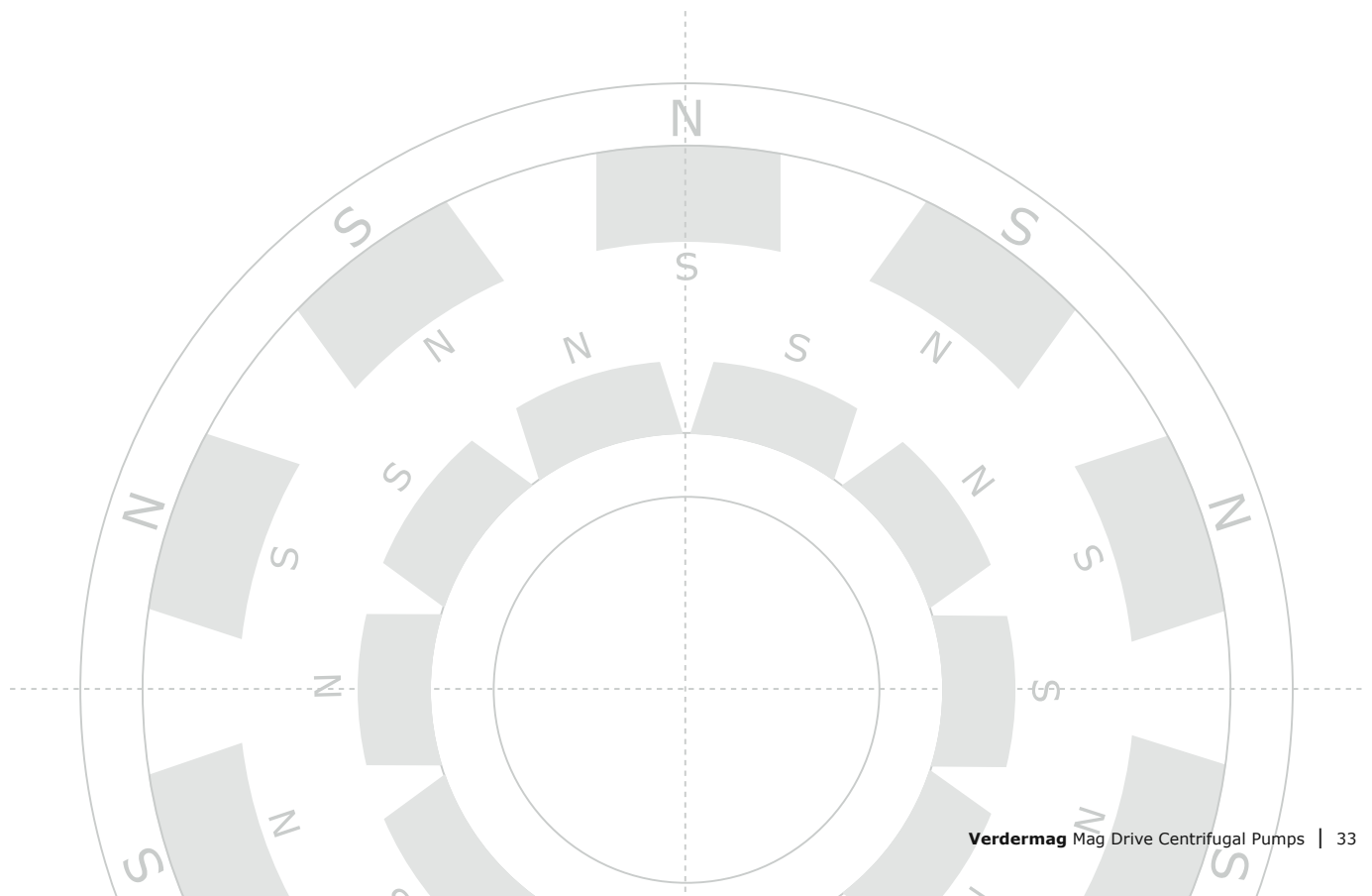



Verdermag

Passion for pumps

Liquids handling is the original passion of Verdermag.

Its liquids handling companies supply a wide range of first-class pumps for a variety of industrial purposes.

Verder Liquids is active in many industrial sectors: chemical and process industry, food, pharmaceutical, water treatment, and environmental industries.

Within these industries pump requirements vary enormously and applications and needs change frequently. In order to ensure we provide the best solutions. We analyse and monitor industrial trends as well as maintaining close relationships with our customers.

International presence

The Verder Group Liquids division has affiliates in:

Austria - Belgium - China - Czech Republic - France - Germany
Great Britain - Hungary - Netherlands - Poland - Romania - Slovakia
South Africa

Your advantages

The advantages of working with us are clear, we offer you:

- single-source solutions: Verder's wide and complementary range of pumps allows you to source your entire pumping needs from one company, reducing your costs;
- expertise: years of providing pumping solutions to industry have given us valuable expertise and knowledge which we are able to use to supply the most appropriate and reliable pumps;
- international affiliated company: our size gives you the confidence that you are dealing with a powerful international pump company and if your project involves overseas work then you can profit from our international network of companies.

Contact Verder

If you would like to know more about our pumping solutions then please visit our website www.verder.com/liquidshandling.

You will find the full range of our pump ranges as well as application stories, latest news and the contact details of our local specialist.



Any questions? You may still have questions and/or comments after reading this brochure. Please feel free to contact us on +31 (0)30 677 92 11. You can also respond via email to info@verder.com. For more information about Verdermag please visit our website www.verder.com/liquidshandling

VERDERMAG

VERDER BV

Utrechtseweg 4a
NL-3451 GG Vleuten
PO Box 1
NL-3450 AA Vleuten

TEL +31 (0)30 677 92 11
FAX +31 (0)30 677 14 02
MAIL info@verder.com
WEB www.verder.com

AT Wien **BE** Aartselaar **CN** Shanghai **CZ** Praha **DE** Haan
FR Eragny s/Oise **GB** Leeds **HU** Budapest **IT** Torre Boldone
JP Tokyo **NL** Groningen/Vleuten **PL** Katowice **RO** Bucuresti/
Sibiu **SK** Bratislava **US** Newtown **ZA** Northriding

