



VERDERMAG GLOBAL

Mag Drive Centrifugal Pumps



Verdermag Global

Verdermag Global is a range of metallic, centrifugal, mag drive pumps that are 100% leak-free and built for exceptional performance.



Many of our customers choose Verdermag Global for ATEX rated zones, environmentally sensitive sites, remote locations and where the workforce is in close proximity to the pump. The choice is attributed to the 100% containment of the fluid and its 'fit and forget' operation.

Mag drive excellence

At Verdermag Global we seek excellence from every aspect of the product, internal processes and customer service. By implementing quality procedures and our special engineering philosophy, we seek to continuously improve and provide the best possible offering to our customers.

Verdermag Global at a Glance

- Hermetically sealed and 100% Leak-free
- No mechanical seals or packed glands
- Up to 200m³/h flow
- Up to 200 bar operating pressure
- Temperature handling of up to 205°C
- Simple, modular design for easy maintenance
- High quality components for long MTBF and reliable, robust performance
- The choice of world class oil companies and engineering specialists
- Tailored pump services for industry directives and organization specification



Working principle

Verdermag Global pumps operate using a 'mag drive' principle, using a two magnet assembly to create flow by transferring torque from the pump shaft to the impeller.

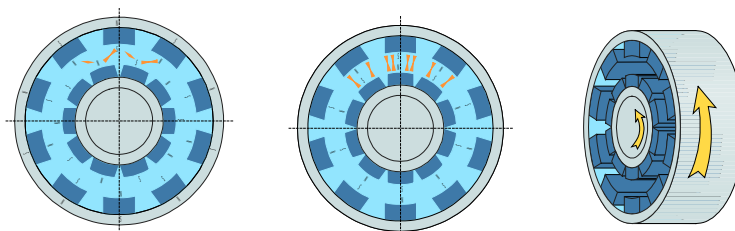

Creating flow

The motor drives the pump shaft, which rotates the outer magnet. The outer magnet 'pulls' an inner magnet, exploiting the polarities in each of the magnets. The inner magnet then rotates the impeller, creating a centrifugal force moving the fluid into the process line.

Self-lubricating

The pump flow path creates a flooded unit, which in normal running conditions allows the pump to run uninterrupted for many years.

100% leak-free

Verdermag Global mag drive pumps are hermetically closed and therefore 100% leak-free. There are no mechanical seals inside the pump. The principal advantage of a Global pump is that the fluid and inner workings are completely contained from the environment with no risk of leaking.

As our mag drive centrifugal pumps are so reliable they are often specified for Atex applications, chemical transfer, solvents, acids or aggressive fluids when offloading tankers.

Premium build quality

The Verdermag Global team have spent over two decades developing trusted relationships with some of the UK and Far East's most reputable suppliers. Our goal is to produce a pump with first-class components that they can depend on. All wet-side components are supplied with 3.1 materials certification for quality purposes.

Bearings

Verdermag Global pumps use high quality silicon carbide bearings. This choice is due to the high tolerance to thermal shock and pressures, extreme hardness and resistance to wear, compatibility with highly aggressive media and perfect construction. Providing the bearing assembly is in a flooded state and free of debris it will run indefinitely.

Castings

Our pump ends are produced using investment casting methods. The use of this method increases the accuracy, consistency and shape of the finished product so the flow is consistent in the assembled pump. Due to the superbly tight tolerances in casting, the containment properties found in the assembled pump are perfect – Ensuring our leak-free design really is 100% guaranteed.

Magnets

For optimum power transfer, our mag drive centrifugal pumps use magnets made from samarium cobalt. This robust material operates across a wide temperature range, has a superior temperature coefficient and is chemically resistant to aggressive fluids.

Paints

The paint specification for our standard pump ranges is double epoxy paint. This paint is very resistant to chemicals, has low porosity and extremely strong bond strength. If your process demands a paint that is compatible with a particular hazard please inform us when specifying your pump.

Motors

Our standard pumps are twinned with market leading quality motors that are chosen for their reliability and efficiency.

Assembly and testing

All pumps are assembled and tested in the Verder Service Centre and subject to stringent quality control inspection and testing procedures.

All design, build and testing procedures conform to ISO 9001/14001.



VERDERMAG GLOBAL MODEL STYLE 1

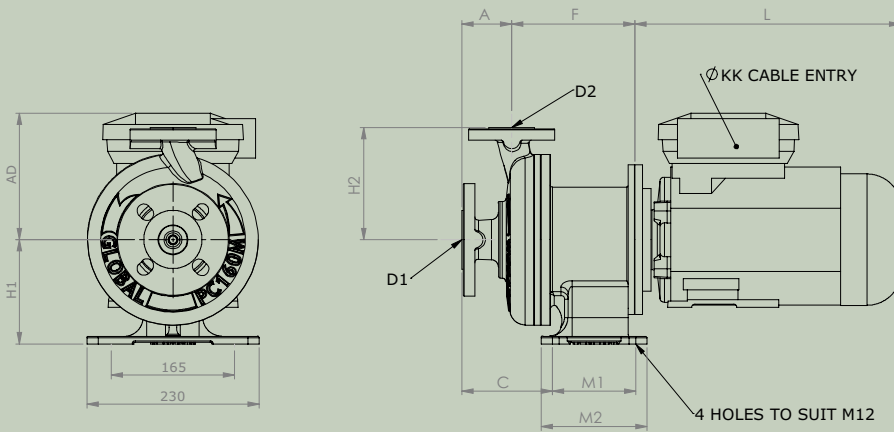

Style 1 pumps offer the same level of high quality design and components as used in our specialist high pressure and Mark 2 ranges at an entry-level price.

Models have flow rates of up to 30m³/h and differential head of up to 40m. The Style 1 Global centrifugal pump is specified by many of our customers as their standard pump for low flow and head duties, OEM applications and standard chemical transfer applications.

Style 1 pumps are renowned for their reliability, 'fit and forget' performance and small factory footprint.

Features and advantages

- Available from stock – low lead times
- Mag drive excellence at a very competitive price point
- Investment cast for high quality finish and increased strength
- Floating bearing design for greater tolerance to thermal and vibratory shock
- Close-coupled motor fit so there is no need for re-alignment after servicing
- ATEX models available
- Universal, PN16 or ANSI 150lb flanges
- Heating and cooling jackets available
- Choice of elastomers to suit a wide range of chemicals

Applications

- Clean-in-place systems
- Chemical transfer
- Thermal oil circulation
- Chemical and polymer production
- OEM
- Manufacturing plants
- Breweries
- Pesticide and insecticide production
- Fertilizers
- Coatings & adhesives
- Caustic and nitric systems
- Tanker offloading
- ATEX



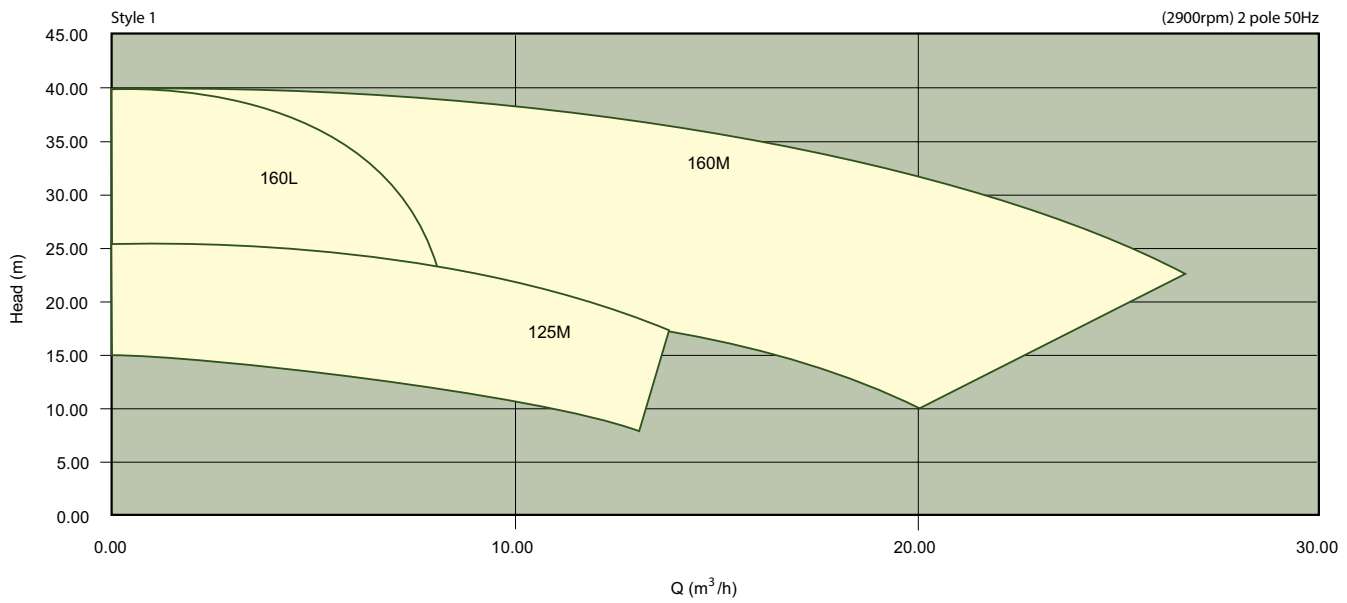
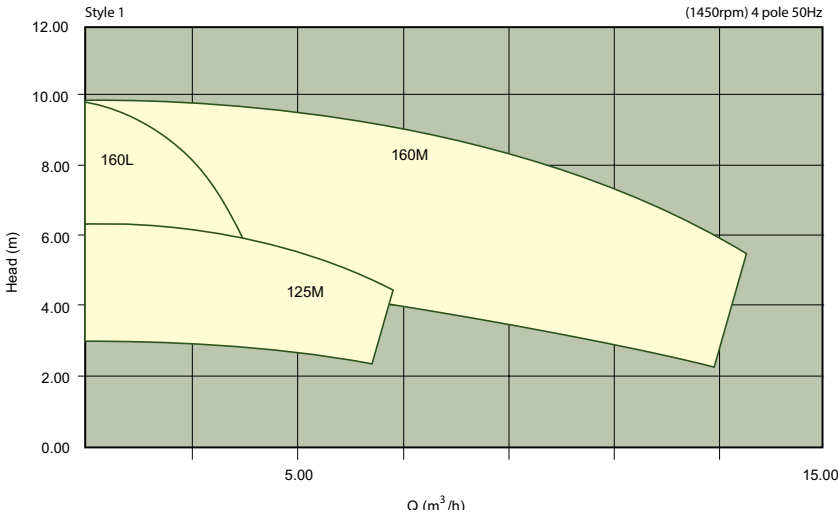

Type	D1	D2	A	C	H1	H2	M1	M2	H
125M	40	25	62	120	139	125	93	141	184/194
160L	40	25	66,5	130	139	150	93	141	165/175
160M	40	25	66,5	130	139	150	93	141	165/175



VERDERMAG GLOBAL MODEL MARK 2

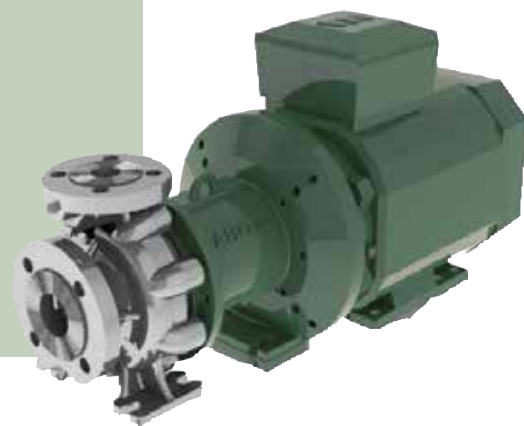
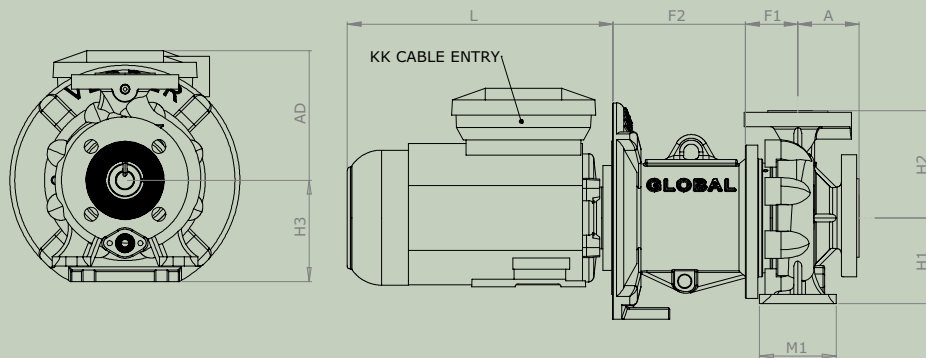

The Verdermag Global Mark 2 style pumps offer medium to high flow and head.

The Mark 2 range of mag drive pumps are suitable for operating at extreme temperatures such as the circulation of thermal oils or condensed gas.

The range conforms to ISO 2858 with ATEX specification available on request. Mark 2 pumps are a superb alternative to shaft sealed pumps as the flange dimensions are identical with the benefit of leak-free operation and a lower cost of ownership over the working life of the pump.

The Mark 2 also features the excellent floating bearing system for protection against thermal shocks.

Features and advantages

- Available from stock – low lead times
- Mag drive excellence at a very competitive price point
- Investment cast for high quality finish and increased strength
- Floating bearing design for greater tolerance to thermal and vibratory shock
- Close-coupled motor fit so there is no need for re-alignment after servicing
- ATEX models available
- Universal, PN16 or ANSI 150lb flanges
- Heating and cooling jackets available
- Choice of elastomers to suit a wide range of chemicals

Applications

- Thermal oil circulation
- Turnkey systems
- OEM
- Power stations
- Manufacturing plants
- Chemical and polymer production
- Gas pipelines
- Refineries
- Coatings and adhesives
- Food manufacturing
- Caustic and nitric systems
- Tanker offloading
- ATEX and ISO2858



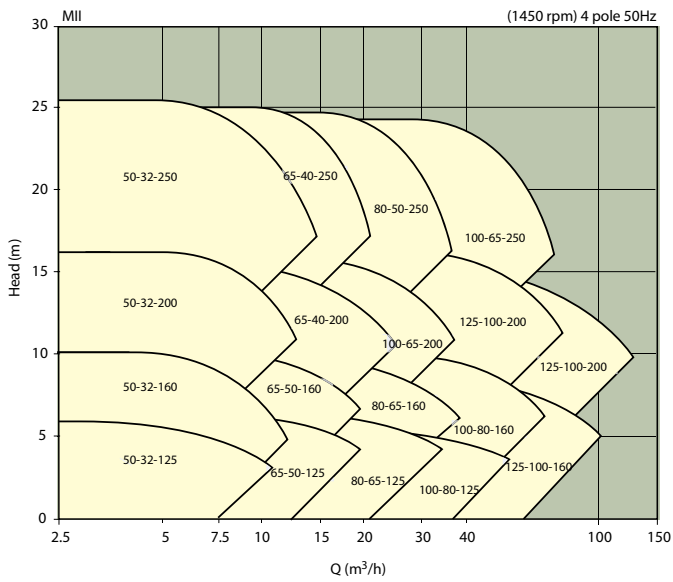

Type	D1	D2	A	C	F1	H1	H2	M1	M2	N1	N2	S1
100-65-200	100	65	100	52.5	97.5	180	225	125	95	320	250	M12
100-65-250	100	65	125	65	92.5	200	250	160	120	360	280	M12
100-80-125	100	80	100	52.5	73.5	160	180	125	95	280	212	M12
100-80-160	100	80	100	52.5	86	160	200	125	95	280	212	M12
125-100-160	125	100	125	65	86	200	250	160	120	360	280	M16
125-100-200	125	100	125	65	98.5	200	280	160	120	360	280	M16
50-32-125	50	32	80	45	73.5	112	140	100	70	190	140	M12
50-32-160	50	32	80	45	71.5	132	160	100	70	240	190	M12
50-32-200	50	32	80	45	89.5	160	180	100	70	240	190	M12
50-32-250	50	32	100	52.5	92.5	180	225	125	95	320	250	M12
65-40-200	65	40	100	65	89.5	160	180	100	70	265	212	M12
65-40-250	65	40	100	52.5	92.5	180	225	125	95	320	250	M12
65-50-125	65	50	80	45	73.5	112	140	100	70	210	160	M12
65-50-160	65	50	80	45	77	132	160	100	70	240	190	M12
80-50-200	80	50	100	65	89.5	160	200	100	70	265	212	M12
80-50-250	80	50	125	77.5	92.5	180	225	125	95	320	250	M12
80-65-125	80	65	100	65	73.5	132	160	100	70	240	190	M12
80-65-160	80	65	100	65	77	160	180	100	70	265	212	M12

Drive Size	F2	H3	M3	S2	W
C3-112	171	132	65	M12	124
C3-132	191	160	65	M12	124
C6-132	224	160	80	M16	164
C6-180	254	180	80	M16	164
D6-180	254	180	80	M16	164

L, AD and KK depending on motor frame size.



VERDERMAG GLOBAL MODEL HIGH PRESSURE

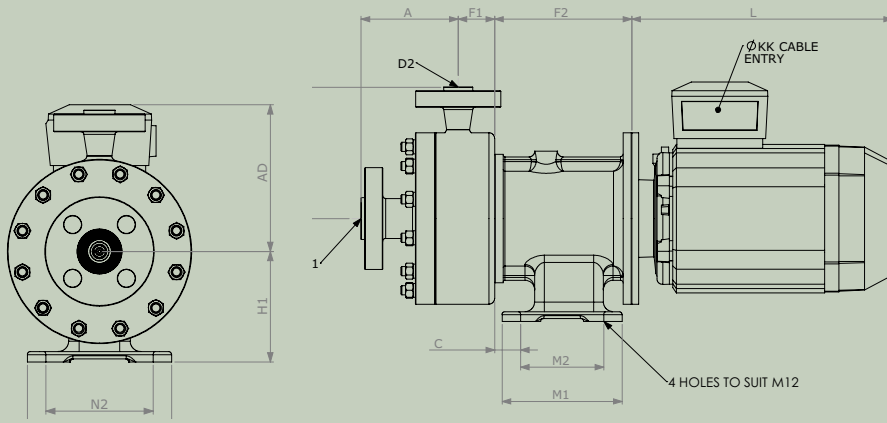

The Global high pressure range of pumps utilises engineering and design excellence in creating a pump that is 100% leak-free with smooth operation at system pressures of up to 200 bar.

Our high pressure units consist of 'standard' models, bespoke fabrication and tailored specification.

The high pressure range offers our customers the optimum balance of product performance, cost, continuity of supply and conformity to specification.

The Verdermag engineering team has designed a range of pumps to suit many of our customer's processes where demands of high pressure, aggressive chemicals and duties are present. In addition to our standard models, the Global team recognise that many high pressure processes have greater demands in a specification set by industry directives such as NACE, Norsok and petrochemical companies.

Tailored solutions

- OEM builds for petrochemical organizations
- Bespoke specification for materials including Hastelloy, Titanium, Super Duplex, all grades of stainless steel, magnets and many more
- Flange and mounting fittings, paints or coatings and test procedure to industry directives or company standards
- 'Open door' policy to design and building a pump for your application

For your records, a full document pack is provided containing test data and 3.1 material certificates.



Applications

- Fast loop oil sampling
- Turnkey systems
- OEM
- Nanofiltration
- Power stations
- Refineries
- Food manufacturing
- Recirculation in high pressure systems

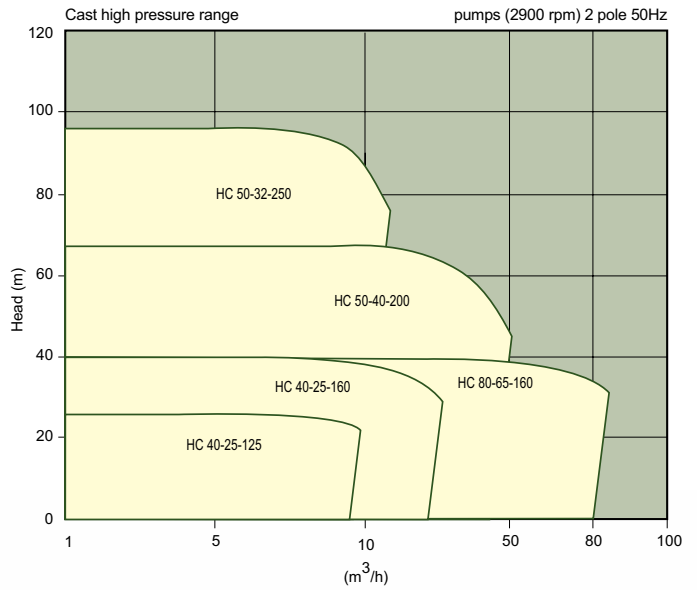
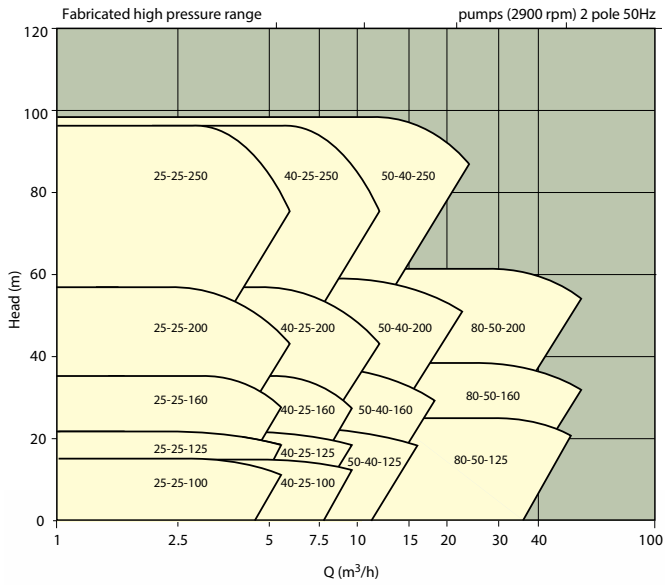

From CAD to oil rig



Design and test facilities to develop our pumps for high level performance



High quality components



Our pumps are assembled with great care and pride



Our pumps are produced for long service life and reliable operation



A Global pump awaiting shipment



The petrochemical sector is just one industry which chooses Global pumps as it is leak-free and performs exceptionally well in critical areas

Service

Tailored specification

Where our customers have specific requirements outside of our standard range we can tailor the pump so it is perfect for their process.

Options include paint, wet-side materials, flange fittings, mountings, motors or to an industry/organization directive.

OEM Pumps

Where your company regularly requires a pump with a specification for a process such as a turnkey system, Verdermag Global can produce a high quality pump at a competitive rate. We produce OEM pumps for several leading process contractors.

Consultation

For customers who require more information on a pump and its suitability for their process, Verdermag Global can provide advice for your fluid type, duties, conformance to directives, power demands, servicing and operation.

The Verdermag Global sales engineers have over 50 years experience in pumps, fluids applications and projects and can advise on the best specification for compatibility, efficiency and cost-effectiveness for your process.

Servicing, repair and refurbishment

Verdermag Global has a state-of-the-art workshop and build facility where pumps can be inspected, serviced, tested and certified. In fact, we repair and refurbish Global pumps that have been installed in processes for over 25 years!

- Spares, repairs and overhaul
- Diagnostic, performance and hydrostatic testing and inspection
- Engineering Technical Support
- Fabricated solutions

'At customer premises' UK services

- Preventative and contract maintenance programmes
- Installation and commissioning
- Pump surveys

Documentation

All drawings, certification and required documents can be produced for your records.





Verder Group

Verdermag Global is a product manufacturer owned by the Verder Group.

Now established for over 25 years, Verdermag Global has benefited from combining the expertise of Engineers, the investment from the Verder Group and the vision of providing the most excellent mag drive pumps in the world.

Based at the Verder UK head offices, Verdermag Global design, build and service all their pumps with stringent quality procedures, excellent components and attentive, friendly customer service.

Verder Worldwide

The Verdermag Global pump has a distributor network around Europe, Asia and the Americas South Africa, Russia, Austria, Czech Republic, Denmark, France, Germany, Hungary, Ireland, Netherlands, Norway, Poland, Romania, Spain, Sweden, Switzerland and Turkey.

For all other countries please contact the Verdermag Global Team.

Contact Verdermag Global

Web: www.verdermagglobal.com

Email: info@verdermagglobal.com

Phone: +44(0)1924 221 001

Fax: +44(0)1132 465649





Any questions? You may still have questions and/or comments after reading this brochure. Please feel free to contact us on +44 (0)1924 221 001. You can also respond via email to info@verdermagglobal.com. For more information about Verdermag Global please visit our website www.verdermagglobal.com

**VERDERMAG
GLOBAL**

VERDERMAG GLOBAL

Unit 3, California Drive
Castleford

West Yorkshire

WF10 5QH - UNITED KINGDOM

TEL +44 (0)1924 221 001

FAX +44 (0)1132 465 649

MAIL info@verdermagglobal.com

WEB www.verdermagglobal.com

AT Wien **BE** Aartselaar **CH** Basel **CN** Shanghai **CZ** Praha **DE** Haan

FR Eragny s/Oise **GB** Castleford **HU** Budapest **IT** Torre Boldone **JP** Tokyo

NL Groningen/Vleuten **PL** Katowice **RO** Bucuresti/Sibiu **SK** Bratislava

US Newtown/Macon **ZA** Northriding