

VERDERMAG
Global PC 160L/M/H
Maintenance Manual



***THIS DOCUMENT SHOULD STAY WITH
THE PUMP UNIT AT ALL TIMES!***

TO BE READ IN CONJUNCTION WITH MAINTENACE MANUAL

Index

1.0 **DOCUMENTATION**

1.1 [Type Hydrostatic Test Certificate](#)

1.2 [Type Performance Certificate](#)

2.0 **MAINTENANCE**

2.1 [Assembly Instructions](#)

2.2 [On Site Disassembly Instructions](#)

2.3 [Tag Plate Detail](#)

2.4 [Standard Sectional Assembly Drawing](#)

2.5 [Component List](#)

3.0 **DIMENSIONS**

3.1 [Tabulated Drawing](#)

3.2 [Flange Standards](#)

3.3 [Universal Flange Dimensions](#)

3.4 [PN16 Flange Dimensions](#)

3.5 [ANSI.150 Flange Dimensions](#)

3.6 [ANSI.300 Flange Dimensions](#)

1.0 DOCUMENTATION

1.1 Type Hydrostatic Test Certificate

Global Style 1 type PC

We hereby certify that the above specified equipment supplied by Verder has been hydrostatically tested in accordance with the current issue of procedure reference VMP.005 and is satisfactory in all respects thereof: -

Test Pressure: 24 barG

Test Temperature: 20 °C

1.2 Type Performance Test Certificate

(For units supplied with drive motor fitted by Verder Ltd in the UK)

Global type PC 160L/M/H

We hereby certify that the above specified equipment supplied by Verder has been tested in accordance with the current issue of procedure reference VMP.007 and meets the following requirements: -

- Standard relevant performance curve at trim diameter detailed on tag plate.
- Duty flowrate and differential pressure detailed within purchase order (where stated).

2.1 Assembly Instructions

Global PC 160L/M/H

The pump unit is assembled to the following procedure in accordance with the standard build specification (see relevant section).

Step 1 Cartridge Assembly

Items required

Reference	Description
2	Pump shaft/impeller assembly
3	Bearing holder
4	Casing joint
5	Backplate assembly
10.1	Front bearing assembly
10.2	Front bearing O-ring kit
11	Rear bearing pins

Note:

Verder advise that where an impeller trim is required on a fabricated impeller, the unit is returned to our works in Leeds (UK). Trimming of a fabricated impeller may disturb the welding of the vanes. The impeller would therefore require re welding ensuring it was fit for purpose.



Front bearing o-ring kits are separated into the two common size o-rings. The smallest set is fitted into the external grooves in the backplate assembly shaft. The largest set is fitted into the internal grooves in the front of the pump shaft and the bearing holder.

Note: Care should be taken not to damage any o-rings. Any o-rings damaged during fitting should be replaced prior to continuation of assembly.

Bearing lubricant is applied to all surfaces machined with o-ring grooves.

Front and rear bearing components can now be fitted to onto/into the relevant components as follows:

Rear bearing pins assembly	->	Backplate
Front bearing thrust ring	->	Bearing holder
Front bearing sleeve assembly	->	Backplate
Front bearing bush	->	
Pumpshaft/impeller		assembly



Note: Care should be taken not to damage any bearing components particularly when passing over anti-rotation pins. Any bearings damaged during fitting should be replaced prior to continuation of assembly.



Warning.

Extreme care should be taken when handling damaged bearings. Silicon carbide is a very hard and brittle material. The edges of any fractures or breaks will be very sharp.



Tip.

When fitting the rear stop pins the pin should be fitted and tapped into place. The pin should then be removed, rotated and re-fitted.

Tapping the pin causes the material to distort ensuring that when the pin is re-fitted a tight fit is obtained.

Position the backplate assembly on a flat surface with the flange upwards.

Note: Ensure that the pumpshaft/impeller assembly is free from particles collected by the magnetised area.

The pump shaft/impeller assembly can now be carefully lowered into the backplate assembly.

The bearing holder is screwed onto the backplate assembly onto the protruding shaft.

(Picture shown details a tool use by Verder to fasten the bearing holder. The tool is available for sale. However the process can be achieved using a circlip remover.





The locknut is then fitted onto backplate assembly onto the protruding shaft with fastener anti-seize. The locknut should be tightened to a torque of 50Nm (36 ft.lb).

Step 2
Outer Magnet Assembly

Items required

Reference	Description
7.1	Outer magnet assembly
7.2	Taper lock adaptor
7.3	Taper lock bush
8.1	Pedestal
8.2	Pedestal adaptor

The outer magnet complete with taper lock adaptor and bush are then lowered onto the motor shaft. The outer magnet setting distance of 3mm, taken from the highest point on the magnet assembly to the highest point on the pedestal (see picture), should now be checked.





Any adjustments in outer magnet height by lifting or lowering the magnet assembly. When the setting distance is correct the screws are tightened. The magnet height is then to be re-checked.

Note: The action of tightening the grub screws affects a 1-2mm increase in the setting distance. Account should be taken of this when setting the rotor.

Step 3
Pump 'wet end' Assembly

Items required

Reference	Description
-	Cartridge assembly
-	Outer magnet / pedestal/motor (when fitted) assembly
1	Casing

The backplate assembly is placed on a flat surface.

The casing joint is then secured into the backplate and the casing lowered onto the assembly and secured with the supplied fasteners using fastener anti-seize. The screws should be tightened to a torque of 40Nm (28.8 ft.lb).

Note:
Care should be taken when assembling the cartridge assembly to the casing to ensure that when assembled the fasteners line up with the correct holes in the pedestal, as detailed below.



The casing/cartridge assembly can now be assembled to the pedestal (bareshaft unit) or the pedestal/motor assembly. The pedestal should be secured using the supplied fasteners with fastener anti-seize. The screws should be tightened to a torque of 40Nm (28.8 ft.lb).

Note: Care should be taken when passing the containment tube into the outer magnet assembly to ensure no damage is caused to the magnets. The correct lifting apparatus should be used to aid fitting of the assemblies.

2.2 On Site Disassembly Instructions

Global PC 160L/M/H

Generally disassembly should be carried out in the reverse order to the assembly instructions detailed above. However the some exceptions may apply dependant on site conditions etc.

2.3 Tag Plate

The tag plate will be supplied with 4 fixing studs and the model code, pump / serial number and test pressure already stamped.

VERDERMAG	
Model	
Date	
Serial No.	
Impeller Ø	mm
Weight	kg
Test pressure	Bar
Speed	rpm
Flow	mCu/hr
Head	m
ATEX 01/03	TECH. FILE REF. 03ATEX0929DR
Temp. Class	
Max Liquid Temp.	
P.E.D. REF	
DO NOT RUN DRY	
	
<small>VERDER Ltd., 3 California Drive, Castleford, WF10 5QH UK www.verderglobal.com +44 (0)1924 221 000</small>	

See code sheet in Installation And Operating Manual

Date of construction

Serial number (required for reference)

Installed final diameter

Pump head weight

Hydrostatic test pressure

Nominal motor speed from motor tag plate

Nominal flowrate

Nominal differential head

ATEX classification (pump head only)

ATEX temperature classification

ATEX maximum allowable pump liquid temperature

** Pressure Equipment Directive notified body EC reference number

The pump model codes are detailed in the Installation And Operating Manual.

* This pump type falls into the list of excluded items contained within the 'Pressure Equipment Directive' 97/23/EC 29th May 1997.

2.4 Standard Sectional Assembly Drawing

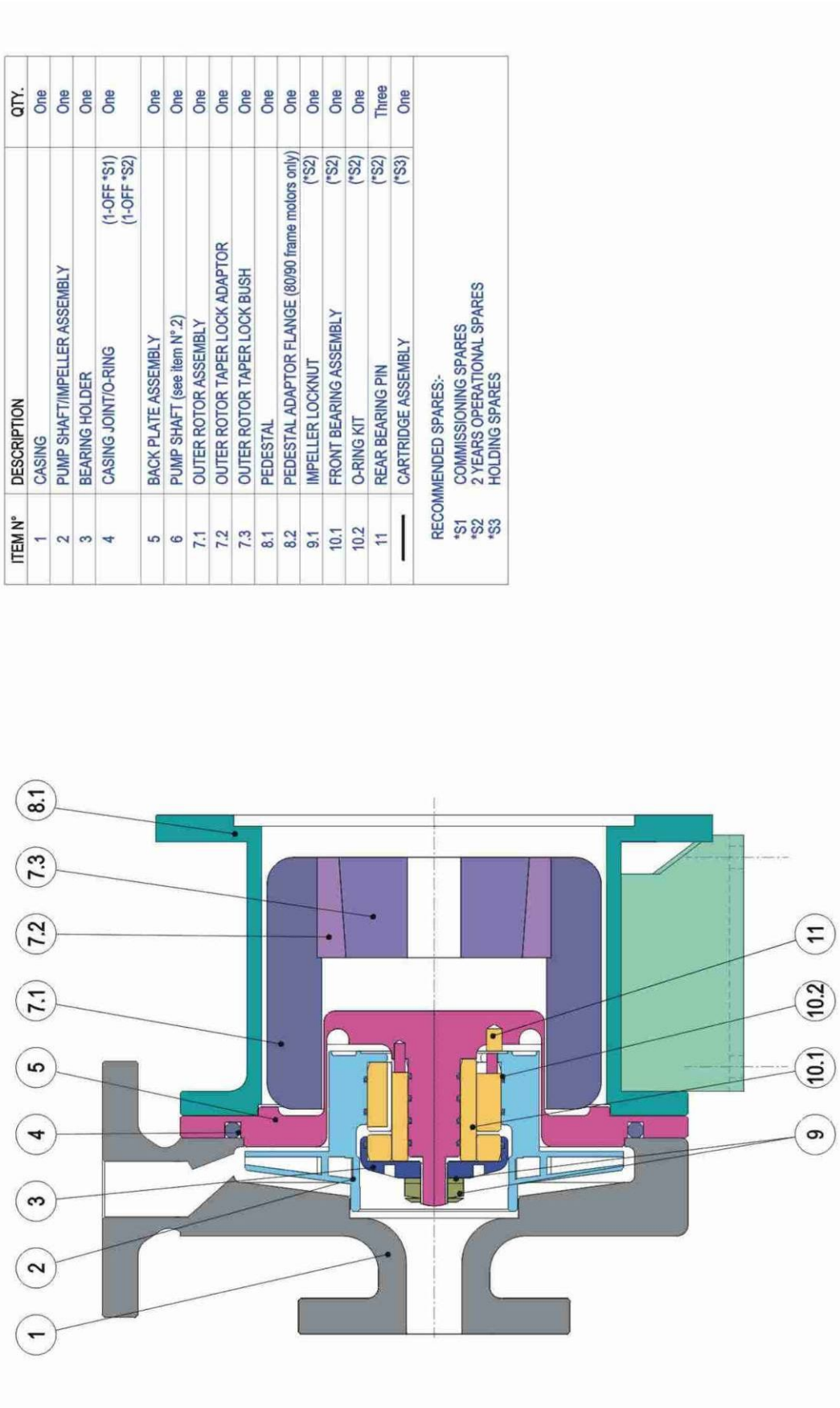

2.5 Component List

PC 160 L / M / H

Item	Part Number	Long Description	Material Specification
1	CAS.1600S	160L CASING CAST STANDARD 316C16	CF8M (316SS)
1	CAS.16001	160L CASING CAST PN16 316C16	CF8M (316SS)
1	CAS.16003	160L CASING CAST ANSI150LB 316C16	CF8M (316SS)
1	CAS.1602S	160M CASING CAST STANDARD 316C16	CF8M (316SS)
1	CAS.16021	160M CASING CAST PN16 316C16	CF8M (316SS)
1	CAS.16023	160M CASING CAST ANSI150LB 316C16	CF8M (316SS)
1	CAS.1604S	160H CASING CAST STANDARD 316C16	CF8M (316SS)
1	CAS.16041	160H CASING CAST PN16 316C16	CF8M (316SS)
1	CAS.16043	160H CASING CAST ANSI150LB 316C16	CF8M (316SS)
2	IMP.160LMH	IMPELLER 160 L M H MACHINED	STAINLESS STEEL CF8M / 316S11 TO BS 1503 / HASTELLOY C276 TO ASTM-SB575-95
3	BHR.160.00	BEARING HOLDER 160 L/M/H 316L	STAINLESS STEEL 316C16 TO BS 1504
4	VIT.160.00	O RING CASING JOINT VITON PC160L/M/H	VITON E-60C
4	EPDM.160.00	O RING CASING JOINT EPDM PC160L/M/H	ETHYLENE PROPYLENE TERPOLYMER
4	PTFE.160.00	O RING CASING JOINT PTFE 160L/M/H BS365	FEP ENCAPSULATED VITON
4	PTFE.160.SP	O RING CASING JOINT PTFE 160L/M/H BS365	SOLID PTFE JOINT
5	BPA.160.00	BACKPLATE ASSEMBLY PC160 L/M/H 3 PINS	STAINLESS STEEL 316S11 TO BS 1503 / HASTELLOY C276 TO ASTM-SB575-95
7	OMR.D1.02	OUTER MAGNET SIZE D1 TO SUIT T/LOCK 2517	MILD STEEL (En3B)
7	TLA.2517	TAPER LOCK ADAPTOR 2517PM	070M20 TO BS 970Pt.1
7	TLB.2517/19	TAPER LOCK BUSH 2517 19mm BORE	070M20 TO BS 970Pt.1
7	TLB.2517/24	TAPER LOCK BUSH 2517 24mm BORE	070M20 TO BS 970Pt.1
7	TLB.2517/28	TAPER LOCK BUSH 2517 28mm BORE	070M20 TO BS 970Pt.1
8.1	PED.D.90.00	PC160 PEDESTAL D1 90 FRAME	ASTM A352-LCB
8.2	PAF.090-112.00	PEDESTAL ADAPTOR MOTOR FRAME 090 TO 112	MILD STEEL (En3B)
9	FKF.160.SS.00	FASTENER KIT 160L/M/H LOCKNUT & WASHER	STAINLESS STEEL 316S11 (WASHERS 316S12) TO BS 1503
10.1	SCB.3	BEARING ASSY SILICON CARBIDE SIZE 3 (E1)	SILICON CARBIDE (SILICA FREE)
10.2	CSS.3	O'RING SET 316L FOR SCB SIZE 3	STAINLESS STEEL 316L
10.2	VIT.3	O'RING SET VITON FOR SCB SIZE 3	VITON E-60C
10.2	EPDM.3	O'RING SET EPDM FOR SCB SIZE 3	ETHYLENE PROPYLENE TERPOLYMER
10.2	PTFE.3	O'RING SET PTFE FOR SCB SIZE 3	FEP ENCAPSULATED VITON
11	FLP.160.3P	FLUOROSCINT REAR STOP PIN 160 (3 PACK)	FLUOROSCINT 500

3.0 DIMENSIONS

3.1 Tabulated Drawing

PC160L/M



Note: All dimensions ±2.5mm

New 160L/M General Assembly

Pump Model	D1	D2	A	C	H1	H2	M1	M2
NEW 160M	40	25	66.5	130	139	150	93	141

Motor size	L	F	AD	KK

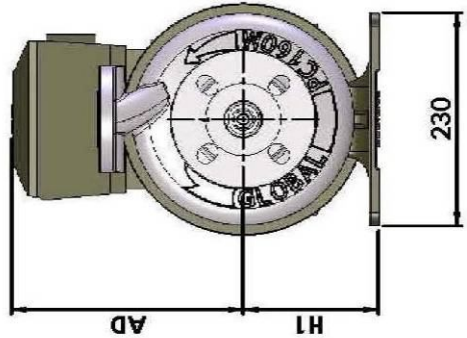
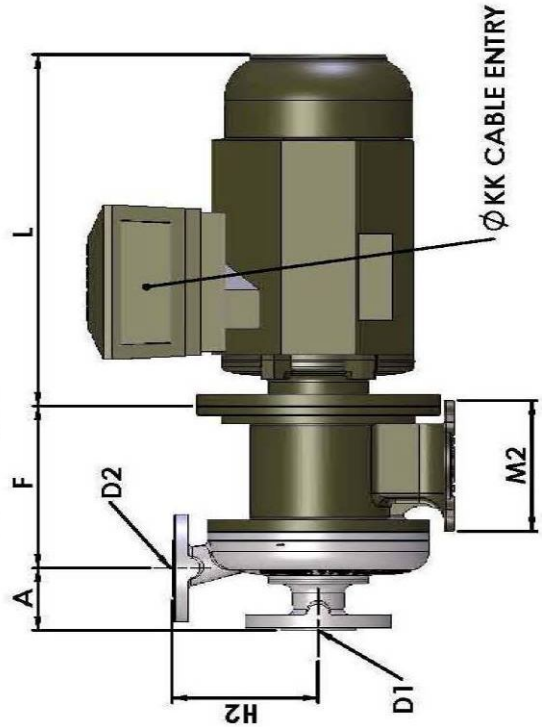
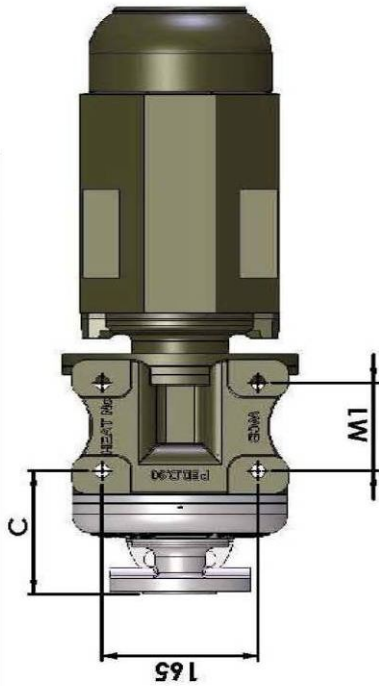

PC160H

VERDERMAG
GLOBAL

Note: All dimensions ±2.5mm

New 160H General Assembly

Pump Model	D1	D2	A	C	H1	H2	M1	M2
NEW 160H	50	40	80	138	139	160	93	141

Motor size	L	F	AD	KK
.				

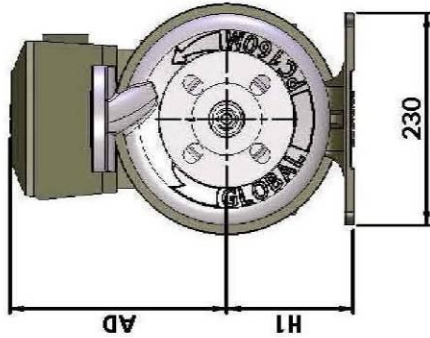
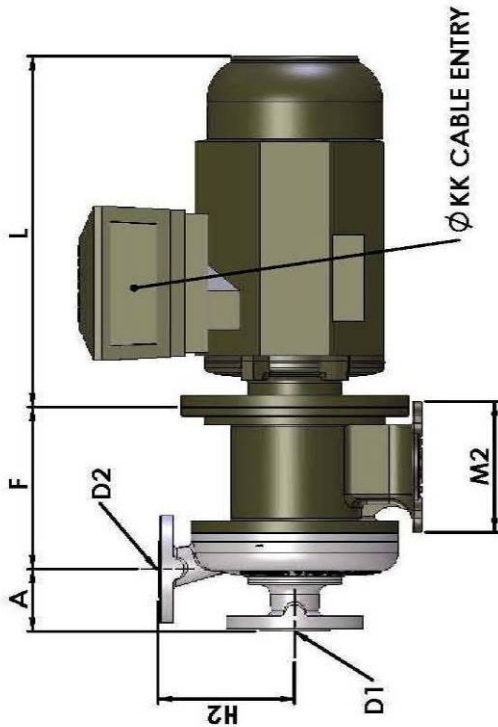
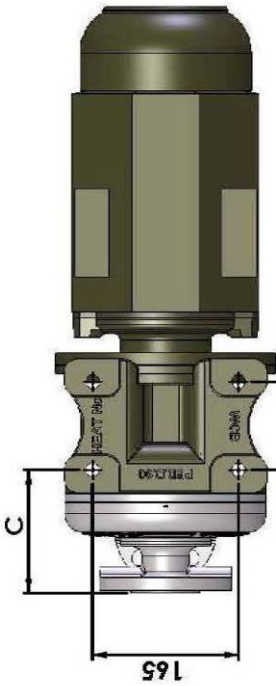

3.2 Flange Standards

Pump Nomenclature

The pump nomenclature includes the essential information required to identify the pump type and the key elements of its hydraulics: –

Example: - PC 100 L for style 1 (sub-ISO) pumps, PC 50-32-125 for MII (ISO) pumps and HC 160 M for High pressure pumps.

The pump code is formatted as a combination of pump type, branch size (inlet / outlet) and nominal impeller size. It is prefixed with the pump type: –

PC – standard (16 bar) Pump Close coupled, HC High system pressure pump Close coupled.

For ISO pumps the remainder of the code details the inlet or suction bore, followed by the outlet or discharge bore, and lastly, the nominal impeller or pump frame size.

For Style 1 pumps, the remainder of the code details the nominal impeller or pump frame size, followed by a letter L for low flow, M for medium flow and H for high flow. These letters equate as follows: -

L = 40mm suction x 25mm discharge
M = 40mm suction x 25mm discharge
H = 50mm suction x 40mm discharge,

Flange Standards

Nominal bore size Metric - Actual	DIN Norm Flanges PN16	Nominal bore size Imperial - Equivalent	ANSI Norm Flanges 150#	ANSI Norm Flanges 300#	ANSI Norm Flanges 600# to 2500#
25mm	25mm	1"	1"	1"	1"
32mm	32mm	1 ¹ / ₄ "	1 ¹ / ₂ "	1 ¹ / ₂ "	1 ¹ / ₂ "
40mm	40mm	1 ¹ / ₂ "	1 ¹ / ₂ "	1 ¹ / ₂ "	1 ¹ / ₂ "
50mm	50mm	2"	2"	2"	2"
65mm	65mm	2 ¹ / ₂ "	2 ¹ / ₂ "	2 ¹ / ₂ "	2 ¹ / ₂ "
80mm	80mm	3"	3"	3"	3"
100mm	100mm	4"	4"	4"	4"
125mm	125mm	5"	5"	5"	5"
150mm	150mm	6"	6"	6"	6"

The pump code reflects the metric sizing. The coding for ANSI flanges is reflected in the more detailed part number (see separate chapter) and not as in ANSI standard pumps: –
e.g. 1515 to denote a 1.5" suction, 1" discharge and 5" nominal impeller.

Flange machining detail

For MII pumps, were the flanges are cast into the casing, the following tables outline our machining practice and indicate any deviations from standards.

Whilst it is possible to provide full 300lb flanges, in reality, the pump case is only rated to 16 bar at ambient, and this will become the limiting factor. By including flanges of a higher pressure rating does not mean the pump can be used for higher pressures.

3.3 Universal Flange Dimensions

DNC	25mm (1")	32mm (1.1/2")	40mm (1.1/2")	50mm (2")	65mm (2.1/2")
DC	-	140	152	165	185
CC	-	18	19	20	20
FC	-	2	3	3	3
D1C	-	78	92	102	122
DM	115	140	150	165	185
CM	16	17.5	17.5	19	22.2
FM	2	2	2	2	2
D1M	61	78	78	100	118
KM1	79.4	98.4	98.4	120.6	139.7
KM2	85	100	110	125	145
No. Holes	4	4	4	4	4
R			R = 1/2 W		
W	16	18	18	19	19
Notes:					
FLG OD	OK	AS CAST	OK	AS CAST	AS CAST
THK'	OK	OK	OK	OK	AS CAST
R/F OD	OK	AS CAST	OK	OK	OK
HOLE ON					
FLG OD	17.8	20.8	25.8	22.2	22.65

Items suffixed with C for cast dimensions

Items suffixed with M for machined dimensions

Where OD of flange and raised face are as cast dimensions. A full 'clean up' of surfaces is required. Tolerance of OD +/-4.00mm, R/F OD +2.00/-1.00mm.

Standard Flange Detail

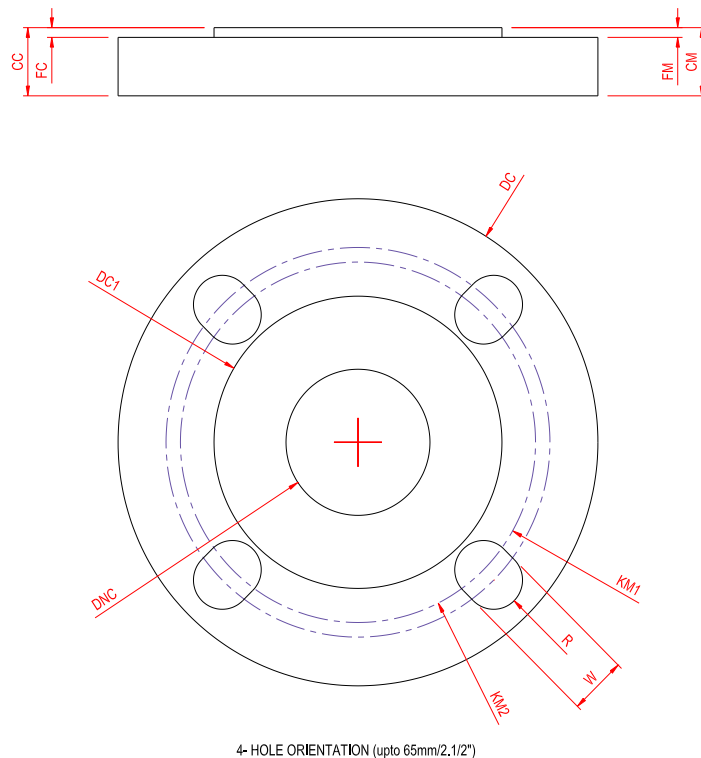

3.4 PN16 Flange Dimensions

DNC	25mm (1")	32mm (1.1/2")	40mm (1.1/2")	50mm (2")	65mm (2.1/2")	80mm (3")	100mm (4")	125mm (5")	150mm (6")
DC	-	140	152	165	185	200	228	254	285
CC	-	18	19	20	20	24	24	26	26
FC	-	2	3	3	3	3	3	3	3
D1C	-	78	92	102	122	138	158	188	212
DM	115	140	150	165	185	200	220	250	285
CM	16	16	16	18	18	20	20	22	22
FM	2	2	3	3	3	3	3	3	3
D1M	68	78	88	102	122	138	158	188	212
KM	85	100	110	125	145	160	180	210	240
No. Holes	4	4	4	4	4	8	8	8	8
Dia. Holes	14	18	18	18	18	18	18	18	18

Notes:

FLG OD	OK	AS CAST	OK	AS CAST	AS CAST	AS CAST	OK	OK	AS CAST
THK'	OK	OK	OK	OK	OK	OK	OK	OK	OK
R/F OD	OK	AS CAST	OK	AS CAST	AS CAST	AS CAST	AS CAST	AS CAST	AS CAST
HOLE ON									
FLG OD	8	11	11	11	11	11	11	11	13.5

Items suffixed with C for cast dimensions

Items suffixed with M for machined dimensions

Where OD of flange and raised face are as cast dimensions. A full 'clean up' of surfaces is required. Tolerance of OD +/-4.00mm, R/F OD +2.00/-1.00mm

General flange detail

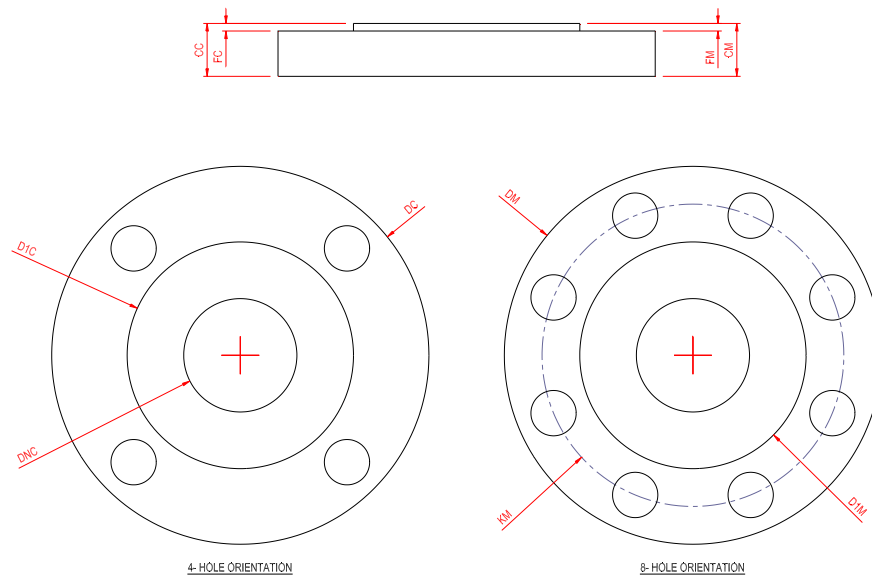

3.5 ANSI .150 Flange Dimensions

DNC	25mm (1")	32mm (1.1/2")	40mm (1.1/2")	50mm (2")	65mm (2.1/2")	80mm (3")	100mm (4")	125mm (5")	150mm (6")
DC	-	140	152	165	185	200	228	254	285
CC	-	18	19	20	20	24	24	26	26
FC	-	2	3	3	3	3	3	3	3
D1C	-	78	92	102	122	138	158	188	212
DM	108	127	127	152	178	190	229	254	279
CM	14.3	17.5	17.5	19	22.2	23.8	23.8	23.8	25.4
FM	1.6	1.6	1.6	1.6	1.6	1.6	1.6	1.6	1.6
D1M	50.8	73	73	92.1	104.8	127	157.2	185.7	215.9
KM	79.4	98.4	98.4	120.6	139.7	152.4	190.5	215.9	241.3
No. Holes	4	4	4	4	4	4	8	8	8
Dia. Holes	15.9	15.9	15.9	19	19	19	19	22.2	22.2

Notes:

FLG OD	OK	OK	OK	OK	OK	OK	AS CAST	AS CAST	OK
THK'	OK	OK	OK	OK	AS CAST	OK	OK	OK	OK
R/F OD	OK	OK	OK	OK	OK	OK	OK	OK	OK
HOLE ON									
FLG OD	6.35	6.35	6.35	6.2	9.65	9.3	9.75	7.95	7.75

Items suffixed with C for cast dimensions

Items suffixed with M for machined dimensions

Where OD of flange and raised face are as cast dimensions. A full 'clean up' of surfaces is required. Tolerance of OD +/-4.00mm, R/F OD +/-0.8mm.

3.6 ANSI .300 Flange Dimensions

DNC	25mm (1")	32mm (1.1/2")	40mm (1.1/2")	50mm (2")	65mm (2.1/2")	80mm (3")	100mm (4")	125mm (5")	150mm (6")
DC	-	-	-	-	-	-	-	-	-
CC	-	-	-	-	-	-	-	-	-
FC	-	-	-	-	-	-	-	-	-
D1C	-	-	-	-	-	-	-	-	-
DM	124	156	156	165	190	210	254	279	318
CM	17.5	20.6	20.6	22.2	25.4	28.6	31.8	34.9	36.5
FM	1.6	1.6	1.6	1.6	1.6	1.6	1.6	1.6	1.6
D1M	50.8	73	73	92.1	104.8	127	157.2	185.7	215.9
KM	88.9	114.3	114.3	127	149.2	168.3	200	235	269.9
No. Holes	4	4	4	8	8	8	8	8	12
Dia. Holes	19	22.2	22.2	19	22.2	22.2	22.2	22.2	22.2

Notes:

FLG OD	OK	OK	OK	OK	OK	OK	OK	OK	OK
THK'	OK	OK	OK	OK	OK	OK	OK	OK	OK
R/F OD	OK	OK	OK	OK	OK	OK	OK	OK	OK
HOLE ON									
FLG OD	8.05	9.75	9.75	9.5	9.3	9.75	15.9	10.9	12.95

Items suffixed with C for cast dimensions

Items suffixed with M for machined dimensions

Where OD of flange and raised face are as cast dimensions. A full 'clean up' of surfaces is required. Tolerance of OD +/-4.00mm, R/F OD +/-0.8mm.

Flange sizes detailed without cast dimensions to be fitted with pre-machined flanges.