



VERDERFLEX®

Industrial Peristaltic Pumps



Verderflex® Industrial Peristaltic Pumps

Why use peristaltic pumps?

Peristaltic pumps are excellent problem solving pumps and offer the following benefits:

- Abrasion Resistant
- No moving parts in the liquid stream
- Accurate Dosing
- Self Priming
- Can pump liquids containing up to 80% inorganic solids (fines)
- Aseptic pumping smooth liquid passage
- Easy and completely cleanable without disassembly
- Suitable for handling shear sensitive products
- Can run dry
- Low cost of ownership
- High suction capability of up to 95% vacuum or a 9.5 mWc
- No seals
- Reversible rotation, empties line or blockages
- Can pump abrasive, very viscous or high density fluids



Application areas

The unique design of Verderflex® peristaltic pumps make them ideally suited to a wide range of application areas, including:

Abrasive fluids

Lime mixing, Kieselguhr, circulation and dosing

Corrosive fluids

Ferric Chloride, Copper Sulphate and similar Activators, process chemicals, Acids, including Alkalis

Shear sensitive fluids

Coagulants, Flocculants and bacterial remediation treatments

Mining Industry

Dosing Process Reagents, Thickener Underflow, polymers and slurry transfer

Water Treatment

Dosing Lime, Hypochlorite, Silicate, Polymer, Ferric Chloride, sludge transfer and filter press feeds

Chemical Industry

Corrosive Acids, Bases and Hydrocarbons

Printing and packaging

Inks (including water based inks), Paints, Dyes and Glue

Battery Filling, Chemical Cleaning, Equipment Sterilising, Seed Coating

Biocides, Hydrogen Peroxide, Sodium Hypochlorite, Caustic Soda

Laboratory Systems

Biological Broths to polluted streams

Agriculture

Feed Additives, Animal Vaccines and Waste Transfer

Paper and Pulp

Pulp and Dyes

Food and Beverage

Breweries, Diatomaceous Earth, wineries, dairies, sugar refining, abattoirs

Verderflex® Industrial Peristaltic Pumps

The Heart Of Your Process

Verderflex® industrial peristaltic pumps are extremely robust, ideal for heavy duty operations on continuous or intermittent duty cycles. They are a simple to use, easy to control, versatile and a reliable way to pump liquids.

With maximum flow rates ranging from 1 l/hr to 90 m³/hr, there is a Verderflex® Industrial pump for most medium to high pressure pumping requirements.



Working principle

1. The peristaltic pump is based on alternating compression and relaxation of the hose or tube drawing the contents into the hose or tube, operating in a similar way to our throat and intestines.
2. A rotating shoe or roller passes along the length of the hose or tube totally compressing it and creating a seal between suction & discharge side of the pump, eliminating product slip.
3. Upon restitution of the hose or tube a strong vacuum is formed drawing product into the pump.
4. The medium to be pumped does not come into contact with any moving parts and is totally contained within a robust, heavy-duty hose or a precision extruded tube.
5. This pumping action makes the pump suitable for accurate dosing applications and has a pressure rating up to 16 bar (hose) and 2 bar (tube).
6. The high pressure hose has inner layer of 2-6 reinforcement layers and an outer layer, which allow higher working pressures and generate higher suction lifts than non re-enforced tubing.

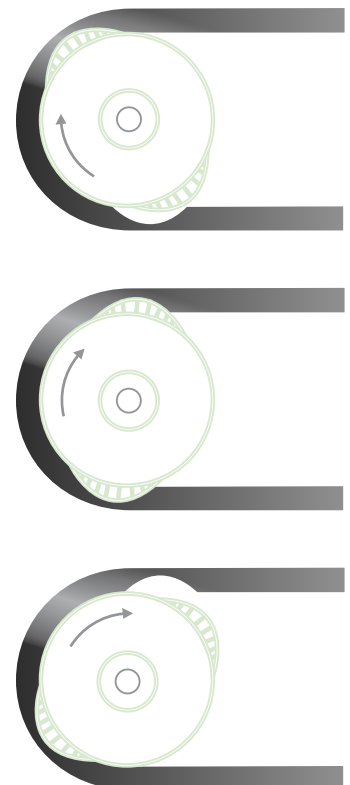



Quick pump selection

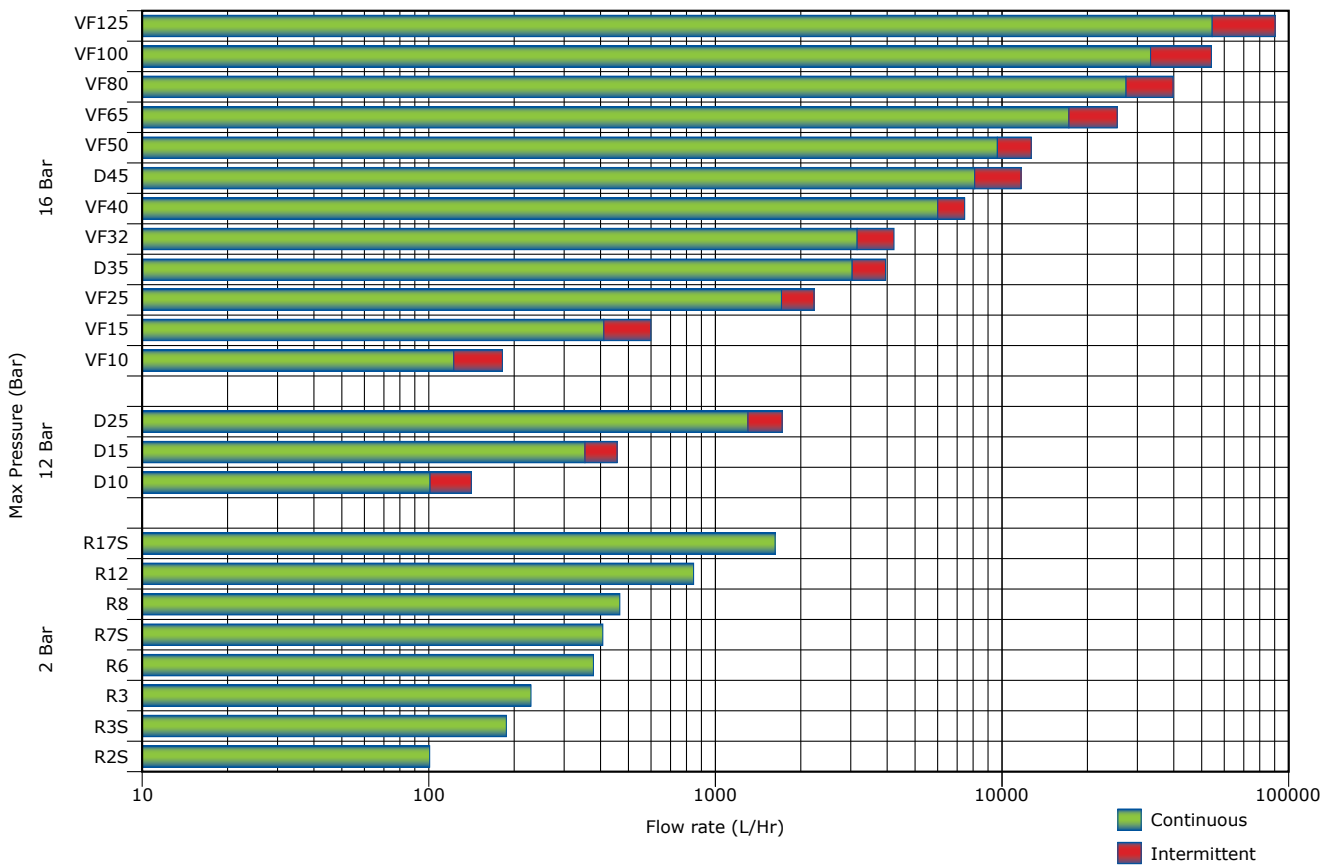



Verderflex® Rapide Tube Pumps

The Verderflex® Rapide is a range of industrial tube pumps that provide a balanced selection of simple to operate peristaltic pumps. The family offers the customer pump choices that are compact, are simple to use and require no tools during the tube change.

The range has been developed to offer reliable and cost effective pumping solutions for industrial applications. Standard designs incorporate rugged aluminium pump heads with "thick-walled" tubing for increased suction lift and IP55 gear motors with both single and three phase options.

The Verderflex® Rapide is an excellent, low flow dosing pump capable of handling viscous, abrasive and chemically aggressive media with total containment and leak free pumping.

Rapide

| | |
|----------------|-------------------------|
| Flow rates | 0.25 ml/min - 17 l/min* |
| Pressure range | up to 2 bar |

* Tested with Verderprene using water



Advantages of the Rapide Tube Pump

- Compact and easy to use
- Can be integrated into third party equipment such as printing presses
- Designed for industrial environments including chemical, mining, printing and water treatment
- Can be used with variable frequency drives (VFDs)

Rapide Specification

| | |
|-------------------------|--|
| Standard Speeds | 68, 93, 137/140 and 196 rpm depending on model |
| Control | inverter optional |
| Voltage | 230/400V 50Hz / 254/460V 60Hz (Single Phrase Available to special order) |
| Installed Motor Power | 0.18kW 50Hz / 0.21kW (0.28HP) 60Hz |
| Standard Tube Materials | Verderprene, Silicone |



Rapide S

The Rapide 'S' has an easy-fit saddle which allows simple and fast tube changes.

The pump head provides:

| | |
|------------|---|
| Flow rates | 3 ml/min - 17 l/min per channel* |
| Option | flexibility to specify up to 4 channels |

* Tested with Verderprene using water



| Rapide 'S' Specification | |
|--------------------------|---|
| Standard Speeds | 60, 113, 151 & 220 rpm |
| Control | inverter optional |
| Multi-channel | up to 4 channels (when factory built) |
| Voltage | 230/400V 50Hz / 254/460V 60Hz (Single Phrase Available to special order) |
| Installed Motor Power | 0.37kW 50Hz / 0.45kW (0.6HP) 60Hz |
| Standard Tube Materials | Verderprene, Silicone |

Advantages of the Rapide 'S' Tube Pump

- Easy-fit tube saddle for rapid tube changes
- Manufactured from chemically resistant Polyoxymethylene (POM)
- Transparent front cover manufactured from Polymethyl-methacrylate (PMMA)
- Pressure range 0-2 bar
- 3 roller heads
- When connected the SSD Safety interlock can stop the drive whenever the saddle is opened or removed
- In-line tube arrangement, providing a kink free liquid path
- Can be used with variable frequency drives (VFDs)

Lightning fast tube change

The easy-fit tube saddle is designed for single handed operation, allowing the tube to be loaded quickly and easily from above, even wearing gloves.



1. Insert the tube on top of the rollers



2. Fit the saddle to one set of dowels



3. Open up the lever and fit the claw over



4. Push the lever down to lock the saddle into place the other set of dowels

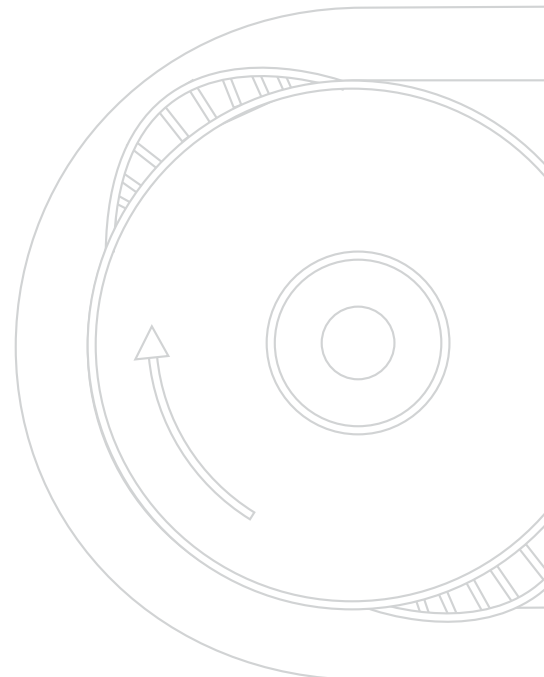



Verderflex® Dura

D10 to D45 Industrial Hose Pump

The Verderflex® Dura is the first real advance in hose pump technology since the high pressure hose by combining the compactness of a close coupled pump, with all the benefits of the traditional long coupled pump.

| | |
|----------------|--|
| Flow rates | 3 l/hr - 12 m ³ /hr |
| Pressure range | up to 12 bar for the D10 to D25 and 16 bar for the D35 to D45 |



Advantages of the Verderflex® Dura Hose Pump

- One piece flange design
- Air gap between pump casing and gearbox for zero risk of cross contamination
- Long coupled design with close coupled advantages
- 70% smaller footprint
- Quick and easy maintenance

Advantages of the Verderflex® Dura 45 Hose Pump

- Rotor supported independently of the gearbox
- Drain channel protects gearbox in case of a hose burst
- Shimmable rotor shoes for precise control of discharge pressure and optimum hose life.
- Ringfeder slip bush protects against a stalled rotor
- Fully supported rotor shoes
- Simple flange assembly reduces hose change downtime

Dura Specification

| | |
|-----------------------|---|
| Standard Speeds | up to 97 rpm depending on model |
| Control | Optional inverter |
| Voltage | 220/400V |
| Frequency | 50/60 Hz |
| Installed Motor Power | 0.15 kW to 7.5 kW |
| Hoses | NR, NBR, EPDM, NBRF**, CSM, Verderprene |

** Hose material only available for the D10 to D25

The Standard Verderflex® Dura Port Flange

- 1 Speeds up hose changes and totally encloses the hose
- 2 Tapered insert section of port flange compresses the hose against the casing for secure hose clamping.
- 3 Cast 316 Stainless Flange
- 4 Universal slotted mating flange, allows connection to DIN PN16, ANSI 150 and JIS 10K

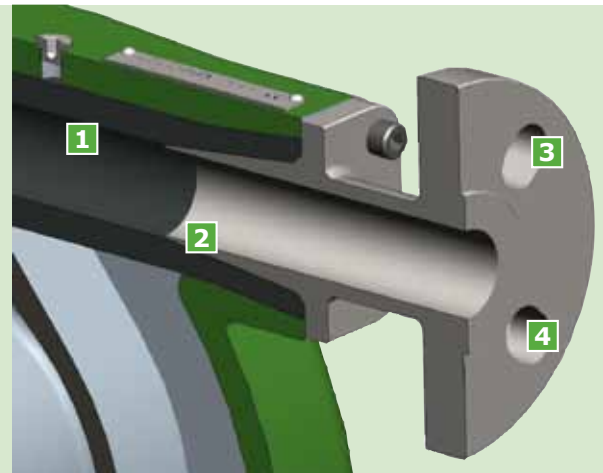

Rotor Locates Over Bearing

- 1 Shaft seal options: Viton® & PTFE
- 2 Rotor mounts directly onto the shaft. Locates over the pair of bearing, minimising overhung load
- 3 Sealed for life bearings are press fitted into the housing

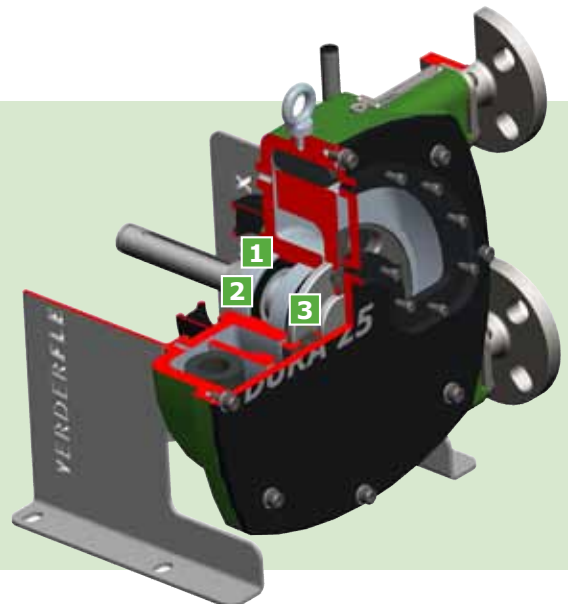

Dura 10 - 35 Gearbox Mounting

- 1 Gearbox is totally isolated from pump head - zero possibility of contamination
- 2 Gearbox slides onto shaft and over shaft key
- 3 Long coupled gearbox is free to move, dissipating energy away from pump

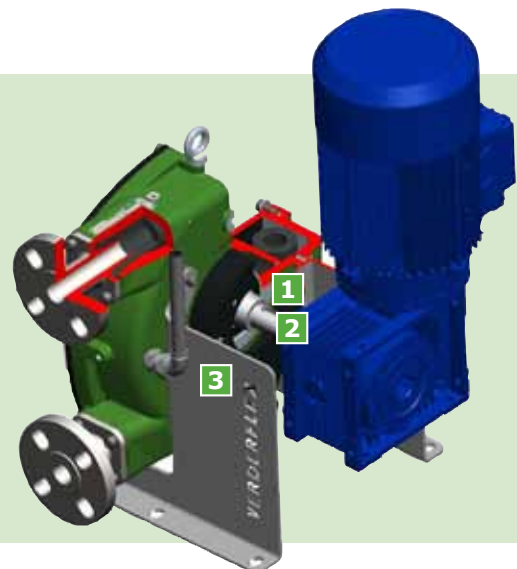



Verderflex® VF Industrial Hose Pump

The Verderflex® range of industrial hose pumps are a proven high quality family of peristaltic pumping solutions. These pumps reduce downtime, minimise maintenance costs and provide easy to operate and reliable solutions in difficult pumping situations.



| | |
|--------------------|-----------------------------|
| Flow rates | up to 90 m ³ /hr |
| Operating pressure | up to 16 bar |

Advantages of the Verderflex® VF Hose Pump

- Specially designed hose construction to reduce fatigue, resulting in longer hose service life
- Disaster proof hose connection for easy maintenance
- Close coupled drive design
- Rigid pump housing design for heat dissipation and strength
- Proven Design

VF Specification

| | |
|-----------------------|--|
| Standard Speeds | up to 87 rpm depending on model |
| Control | Optional inverter |
| Standard Voltage | 220/400V to 7.5 kW, 400/690V above 9.2kW |
| Standard Frequency | 50/60Hz |
| Installed Motor Power | 0.12 to 37 kW |
| Hoses | NR, NBR, EPDM, CSM & NBRF |

The Verderflex® VF Port Flange

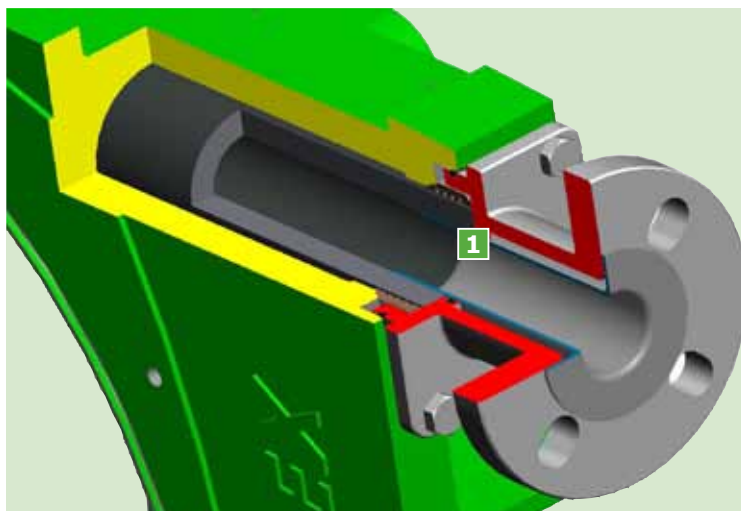

- 1 When fitted with hygienic flanges (e.g. DIN 11851, Triclamp or RJT) the pump meets EHEDG Standards





Verderflex® Hose and Tube

Advancements of the Verderflex® hose

The Verderflex® hose has more re-enforcements than the competitors and maximises hose life by optimising the fatigue strength.

The hose is available in 12 standard hose sizes from 5 mm (3/16") to 125 mm (5"). The surface properties of the hose offer many advantages:

- Exact wall thickness and outer diameter tolerances are maintained at each and every point
- No additional process of external machining
- Tested alongside competitors, results indicate that there is no additional friction due to the textured finish surface
- Textured surface creates micropockets of lubrication, promoting more even lubricant coverage, extending hose life



| | | | |
|--------------------|---|------------------|--|
| NR |  | White | The most common hose for all market segments |
| NBR |  | Yellow | Suitable for use with oily and fatty products |
| NBRF |  | White/ Yellow | Has a FDA CFR21 & EC No. 1935/2004 approved food grade liner |
| EPDM |  | Red | Exceptionally resistant to corrosive chemicals |
| CSM |  | Green | Used to pump highly corrosive products |
| Verderprene |  | Beige | Special low pressure, low spallation hose for Dura |

VERDERFLEX® TUBE SELECTION

Verderprene - General Purpose Tubing

This opaque, cream coloured tube is the most popular choice for tube pumps (FDA & USP compliant).

Platinum Cured Silicone - For Higher Purity

Platinum cured Silicone is a translucent, odourless tubing with low residuals (FDA & USP compliant).

Other materials including Tygon® and Viton® are available on request!

Successful Applications



Anaerobic Digestion Sludge Transfer

Verderflex® pumps were specified due to the high suction lift and the sludge's solid content. The pumps transfer sludge to digestion tanks, as part of a biofuel energy plant.



Thickener Underflow Slurry

On the basis of proven performance, 6 x VF125s pump 60% to 80% solid content, 1.8 SG chrome and platinum slurry at the world's largest Platinum concentrators in South Africa.



Dosing and Transfer of Refuse Leachate to Incinerators

The Suzhou Waste Incineration Plant have installed 12 Verderflex® peristaltic pumps as part of the leachate process and injection system. The abrasive leachate is pumped from the collection reservoir, through an automatic cleaning filter and collected in a draining reservoir.



Calcium Hypochlorite $\text{Ca}(\text{ClO})_2$ Dosing

3 x Dura 25 with PP flanges replaced problem vapour locking diaphragm dosing pumps Calcium Hypo diaphragm pumps. Sterilisation of water supply is dependent on Hypochlorite being dosed and this water is then supplied to one of Johannesburg's largest informal settlements.



Copperas Crystal Dosing

Copperas crystals (solid Ferrous Sulphate FeSO_4) are mixed at a power station to form a liquid that is re-circulated and dosed by Dura 15 pumps to form a protective iron coating on titanium condensation tubes.



Pumping Kieselguhr

Several Dura 25 pumps dose and transfer Kieselguhr or Diatomaceous Earth in a Bavarian brewery's beer filtration process, filtering 1200 hl of beer every 8-10 hours filtration cycle.



Water Based Ink Transfer

A change to water based inks resulted in final product quality issues as the original AODD pumps experienced foaming problems for this printer. Dura 15 pumps are now fitted onto each print line, eliminating bubbles in the ink because of the Dura's gentle pumping action.

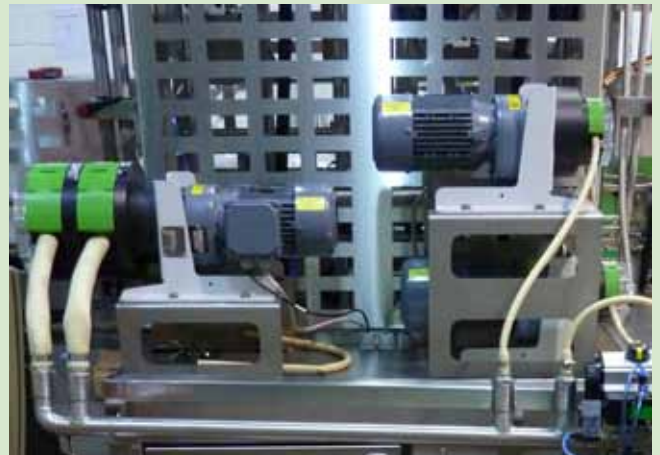

Filling UV Ink Bottles

A digital photo processing plant commissioned a factory profitability expert to eliminate manual UV ink bottle filling. The concept was approved using stand alone Rapide R3S's & R17S's, leading to purpose designed filling stations each using 4 x 2 channel R17S.



Contact Verderflex®

If you would like to know more about Verderflex® peristaltic pumps then please visit our website www.verderflex.com where you will find the full breakdown of our pump range as well as application stories, latest news and technical datasheets.

Verderflex,
Verder Ltd,
Unit 3, California Drive,
Castleford,
WF10 5QH
United Kingdom
Tel: +44 (0) 1924 221 020
Email: info@verderflex.com

To provide you and experienced independent with the best possible service Verderflex® are supported by a distribution network that covers all five continents and is continuing to expand. Our group of distributors includes members of the Verder Group and experienced independent companies. Our worldwide distribution network also help to provide local support and spares availability provide our customers with local support.

You can find your local distributor on our website at www.verderflex.com



Any questions? You may still have questions and/or comments after reading this brochure. Please feel free to contact us on +44 (0)1924 221 020. You can also respond via email to info@verderflex.com. For more information about Verderflex® please visit our website www.verderflex.com

VERDERFLEX®

VF_broch_industrial_rev03-2013_UK-(uk)

VERDERFLEX LTD

3 California Drive,
Castleford
West Yorkshire, WF10 5QH
United Kingdom

TEL + 44 (0) 1924 221 020
FAX + 44 (0) 1132 465 649
MAIL info@verderflex.com
WEB www.verderflex.com

AT Wien **BE** Aartselaar **BG** Sofia **CH** Basel **CN** Shanghai **CZ** Praha
DE Haan **DK** Rødovre **FR** Eragny s/Oise **GB** Castleford **HU** Budapest
IN Pune **NL** Groningen/Vleuten **PL** Katowice **RO** Bucuresti/Sibiu
SK Bratislava **TH** Bangkok **US** Macon (GA) **ZA** Northriding

