

# Verderair

## VA-P40





VA-P40

VERDERAIR

Technical data VA-P40			
Nominal port size	Code NO.6	TN	1 1/2" NPT[f]
		FD	DN40
		FA	1 1/2"
		FJ	1 1/2"
Air inlet			R 1/2"
Weight [kg]		VA-P40EE	39
		VA-P40GG	36
		VA-P40TT	87
		VA-P40UU	82
Max. operation pressure [Bar]			7
Max. operating temperature [°C]		VA-P40EE or VA-P40GG	70
		VA-P40TT or VA-P40UU	120
Max. size pumpable solids [mm]	Code NO.3	EP or TF or SS	9
		CV	/
Max. Suction lift dry [mWc]	Code NO.3	EP or TF or SS	4
		CV	5
Max. Suction lift wet [mWc]	Code NO.3	EP or TF or SS	9,5
		CV	9,5

### CODE VA-P40 No.1 No.2 No.3 No.4 No.5 No.6

#### No.1 Housing & Center Section/ No.2 Valve seat

- EE EE = Polyethylene (PE UHMW)
-  GG GG = Conductive Polyethylene (PE UHMW)
- TT TT = PTFE
-  UU UU = Conductive PTFE

#### No.3 Valve balls

- EP = EPDM
- TF = PTFE
- CV = Cylinder Valve

#### No.4 Diaphragms

- EO = EPDM Overmolded
- TO = PTFE Overmolded

#### No.5 Fluid connections

- TN = NPT Threaded female
- FD = Flanged DIN
- FA = Flanged Ansi
- FJ = Flanged JIS

#### No.6 Options

- OO = Standard, no option
- RE = Remote
- PD = Ready for Pulsation Dampener
- VS = Vertical Suction
- BS = Barrier system with Sensors only
- LS = Leak detection, Sensor only
- SS = Stroke Sensor
- DM = Draining Manual
- DP = Draining Pneumatical
- AP = ANSI Prepared

 II 2GD c II B Tx

#### EXAMPLE PUMP TYPE

EXAMPLE : VA-P40EE EE TF TO TN OO



# Verderair VA-P40

VA-P40

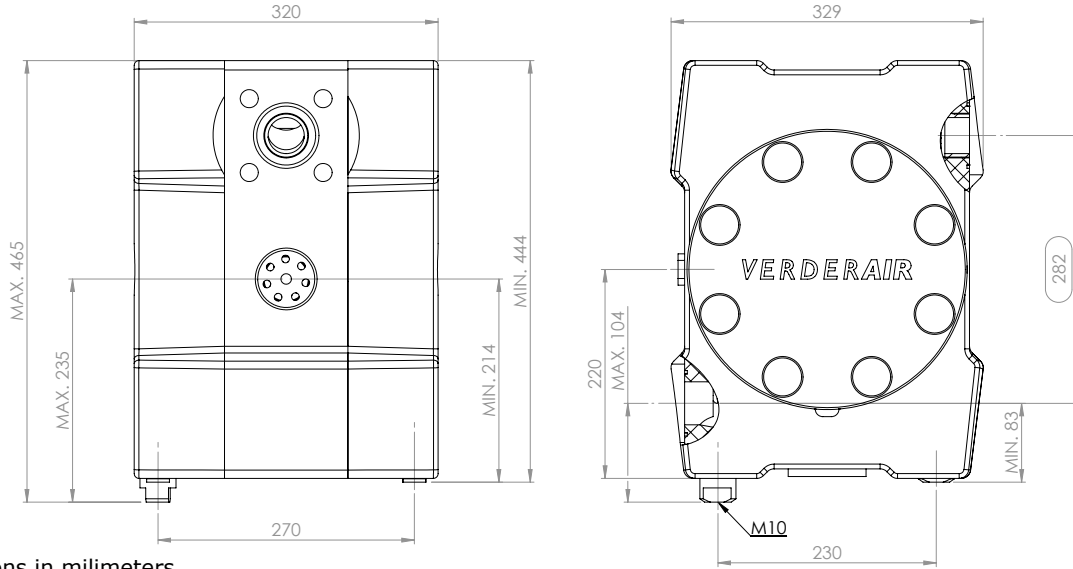

Dimensions in millimeters

