

Verderair

VA 8

VA8PP



VERDERAIR

Technical data		
Weight [kg]	Acetal	1.1
	Polypropylene	0.9
	Kynar	1.3
Suction lift [mwc]	Dry	2.5
	Wet	4.4
Temperature [°C]	Acetal	82
	Polypropylene	82
	Kynar	82
Max. particle size [mm]		1.5
Non wetted material, centre section	Polypropylene	

CODES VA 8 NO.2 NO.3 NO.4

no.2 material of casing

Ex AC = Acetal
PP = Polypropylene
KY = Kynar

no.3 material of valve

AC = Acetal
PP = Polypropylene
KY = Kynar

no.4 material of diaphragm

TF = Teflon
SP = Santoprene

Ex II 2 GD c IIC T4

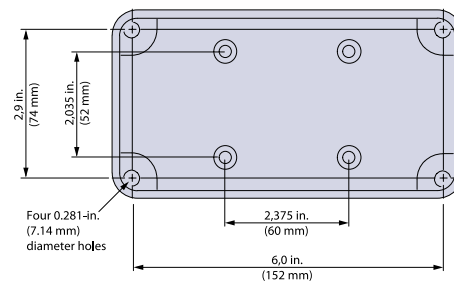
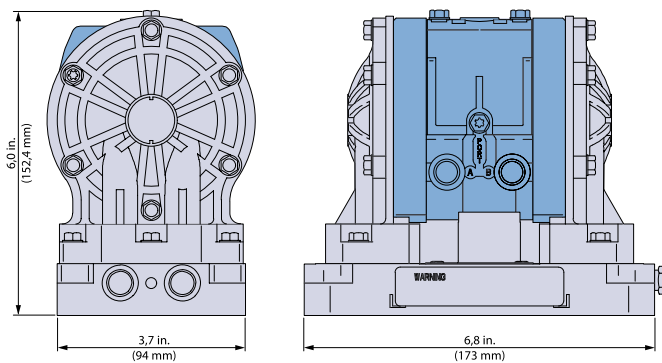
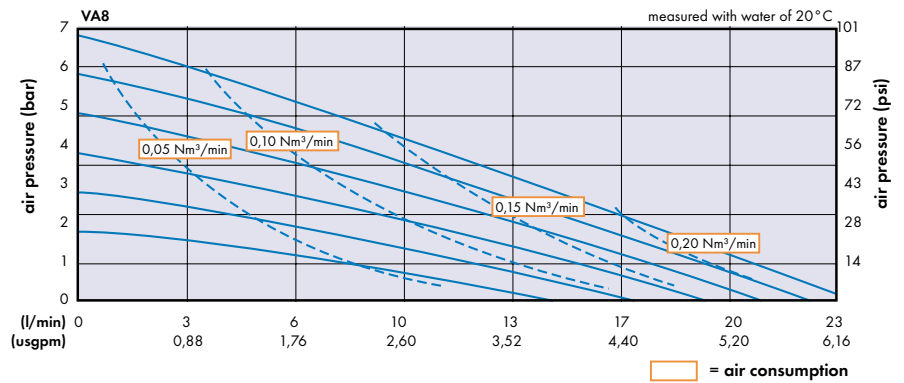

Find your local supplier at www.verderair.com

VERDER
passion for pumps