

# Fish Slurry & Water Treatment

*Fish farms need to consider the management of water more than most industrial sites. The management of the water itself is crucial to the healthy state of the fish and the end quality of the product. The processing of the fish into the product also requires a specialist pump to handle the thick, oily, slurry which contains abrasive scales, bones and debris from the water. Verder were able to assist two fisheries with these issues.*



## Process issues

- Abrasive product
- High volume of solids
- Dry-running & Suction lift
- Mobility/Flexibility of water treatment



A fish processing plant in northern France fillets whole fish, then processes the remaining parts for petfood and frozen blocks for shark attractants.

The existing process was quite basic - A single man shovelling the slurry between the macerator vat receptacle and the container trolley which can be wheeled to the next stage of the process.

The manager of the plant approached Verder, asking if they could provide a pumping solution to speed up the process.

Verder recommended using a Verderflex peristaltic pump to handle the fish slurry.

This selection is due to the peristaltic working principle of a flexible hose and rotor allowing the easy passage of the fish slurry. The rotor both draws in and pushes out thick, viscous product.

The product, which features fish bones, grit and scales is very abrasive, however, no working parts come into contact with the slurry. The hose compresses as the rotor moves round, creating a temporary seal so the product can be moved without any abrasive wear.

The processing plant was delighted that they could now redeploy the labourer and the process time had been reduced greatly.



Left: A fresh batch of fish being delivered in to the processing line for filleting.

Below: The remaining fish fish being passed through a macerator to create a slurry for the byproducts.

The product is oily, abrasive and contains a large number of solids such as bones and scales.



A Verderflex VF peristaltic pump transferring the fish slurry. The unit uses a positive displacement principle to move the slurry. A Verderflex pump can handle thick, viscous slurries, run dry and provide a powerful suction lift.





A fish farm in Scotland required a dosing solution.

The fish farm contained a large tank of salmon. As the fish excrete, the water requires filtering to maintain a level of purity for their health and the end quality of the product.

The water is channelled from the tank and filtered to remove solid matter, however the water is left with higher levels of acidity. The water was dosed with lime chemical and returned to the tank.

The fish farm approached Verder for a dosing solution.

Verder recommended a Dura packaged dosing system.

The system was recommended as it provided a dosing solution for a smaller flow rate with a built-in monitoring probe, analyser pump, inverter and electrical distribution.

This was perfect for the fish farm's requirements. The system comes complete with a mixer unit which can be mounted on to any standard IBC.

The dosing system is designed to handle abrasive lime chemical thanks to the peristaltic pump principle.

The unit has been operating successfully for several months providing pH correction ensuring the water quality remains stable and suitable for the fish.



*Above: The Verder dosing system - A complete packaged unit for monitoring and delivery of chemical.*

*Right: A cutaway diagram of the Verder dosing system and mixer unit as installed on an IBC. The unit can be hooked onto any standard IBC. The mixer unit featuring collapsible blades.*

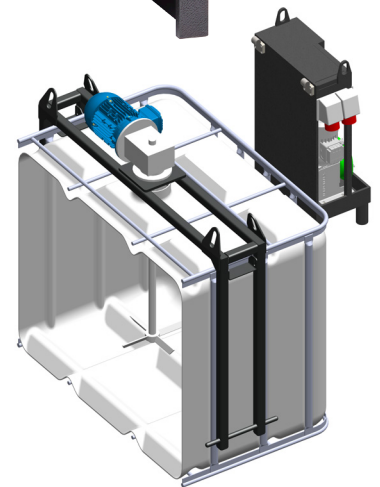

[www.verder.co.uk](http://www.verder.co.uk)

AT Wien BE Aartselaar BG Sofia CH Basel CN Shanghai CZ Praha  
DE Haan DK Rødovre FR Eragny s/Oise GB Castleford HU Budapest  
IN Pune NL Groningen/Vleuten PL Katowice RO Bucuresti/Sibiu  
SK Bratislava TH Bangkok US Macon (GA) ZA Northriding

**VERDER**  
passion for pumps

