

COMPACT

Our latest machine development still produced here in our own factory. This machine combines all our previous experience and knowledge in building drilling machines but at a reduced cost base. It is lighter than previous models yet still robust and rigid. Not intended as a full time production machine it still offers performance and accuracy to the highest order for the lighter user.

Originally developed as a bench mounted machine it can be supplied as a floor standing machine to special order, the rack elevating system for the intermediate table can be supplied as an optional extra.

Supplied complete with chuck and chuck guard as shown.

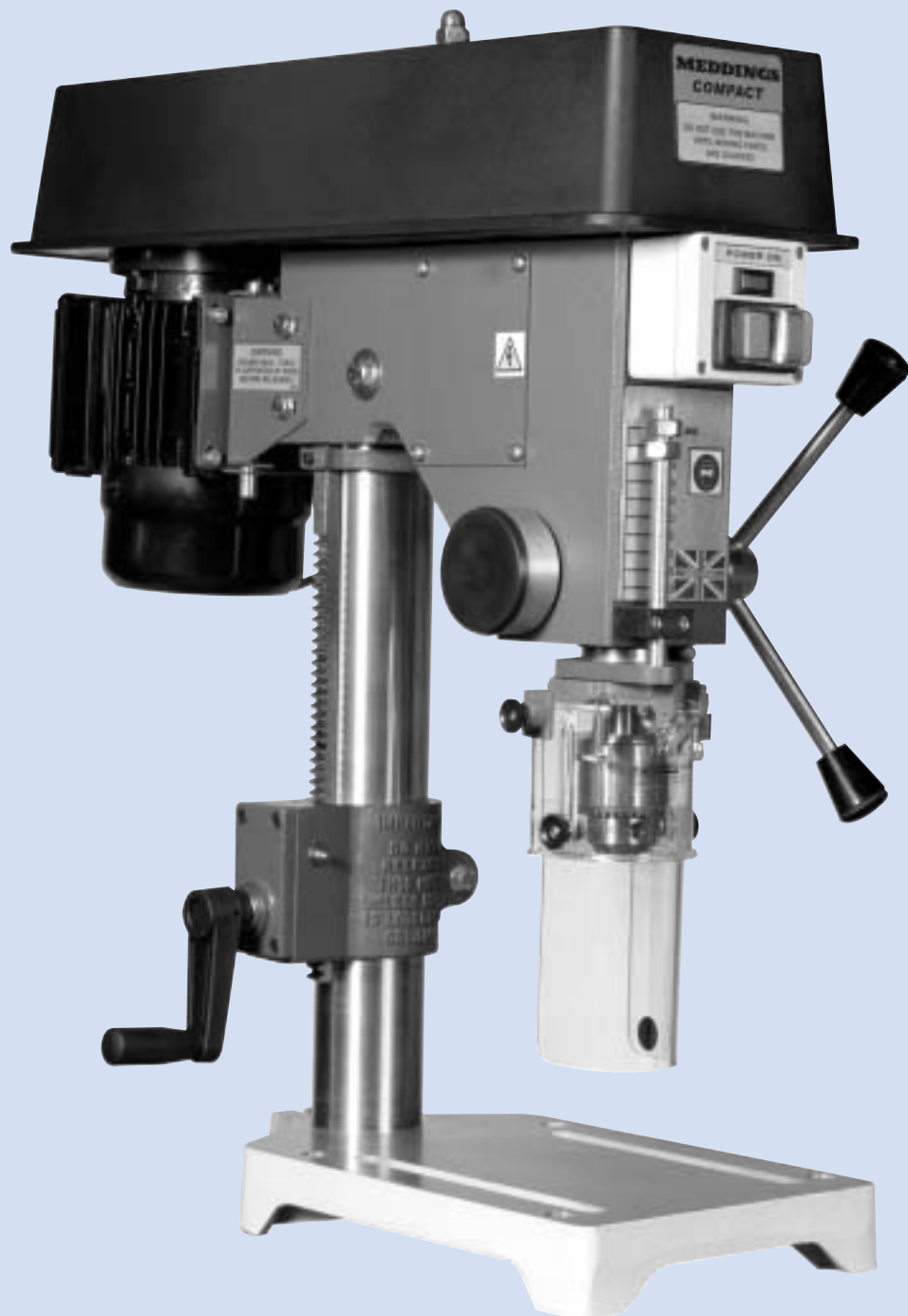



COMPACT FLOOR MODEL
SHOWING OPTIONAL TABLE
RAISING MECHANISM

TECHNICAL DATA

	BENCH		FLOOR		
Drilling capacity in mild steel	13 mm				
Motor	0.25kW 1 phase				
Spindle	Fitted chuck				
Drive	Belt, stepped pulleys				
Spindle speeds rpm 50Hz	500	900	1400	2300	4000
Spindle travel	100 mm				
Throat depth	194 mm				
Column diameter	70 mm				
Table - overall	n/a	235 x 409 mm			
Table - working surface	n/a	235 x 295 mm			
Base - overall	235 x 409 mm				
Base - working surface	235 x 295 mm				
Max distance chuck to table	n/a	1077 mm			
Max distance chuck to base	294 mm	1258 mm			
Overall height	815 mm	1577 mm			
Overall width	372 mm	372 mm			
Overall depth	627 mm	627 mm			
Approx nett weight	46 kg	61 kg			

L1 mark V and L2 mark III series

Developed from our earlier, long running, series these models feature 2 MT spindles with increased drilling capacities, the L1 series effectively replace the earlier L2 models and the new L2 replaces our earlier M4 series thus offering better value.

The L2 models feature a 2 speed motor to extend the available speed range.

Items now included as standard - rack and pinion table adjustment, worklight and base mounted stop switch - were previously available as optional extras.

All machines are supplied complete with chuck guards as illustrated.

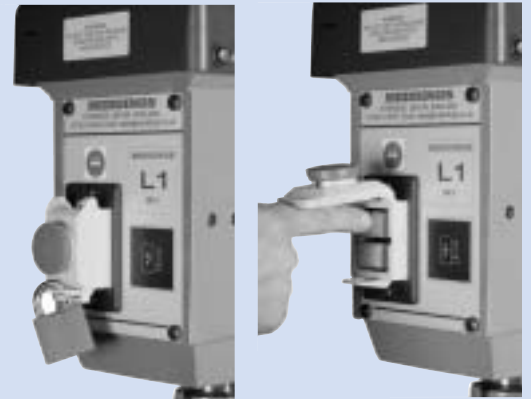

LB1 LF1 LB2 LF2





TECHNICAL DATA

	LB1	LF1	LB2	LF2
Drilling capacity in mild steel	18 mm		23 mm	
Motor	0.45kW 1 or 3 phase		0.45/0.75kW (2 speed) 3 phase	
Spindle	2 MT		2 MT	
Drive	Belt, stepped pulleys		Belt, stepped pulleys	
Spindle speeds rpm 50Hz	400-700-1200-2100-3600		200-350-400-600-700-1050-1200-1800-2100-3600	
Spindle travel	75 mm		75 mm	
Throat depth	185 mm		185 mm	
Column diameter	70 mm		70 mm	
Table - overall	300 x 390mm		300 x 390mm	
Table - working surface	240 x 290mm		240 x 290mm	
Base - overall	240 x 360mm	357 x 523mm	240 x 360mm	357 x 523mm
Base - working surface	n/a	n/a	n/a	n/a
Max distance spindle to table	330mm	740mm	330mm	740mm
Max distance spindle to base	n/a	n/a	n/a	n/a
Overall height	865mm	1710mm	865mm	1710mm
Overall width	280mm	280mm	280mm	280mm
Overall depth	600mm	600mm	600mm	600mm
Approx nett weight	77 kg	133 kg	84 kg	140 kg

D.C. Injection Braking

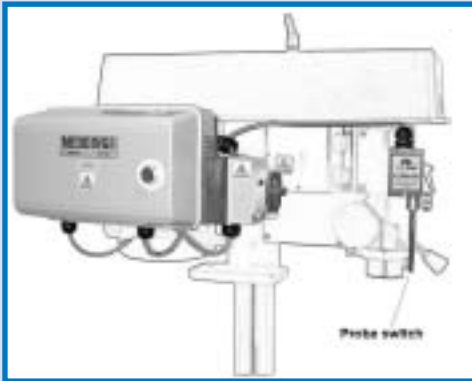

A positive means of stopping the machine in the event of any emergency. When actuated the system instantly cuts off the AC supply to the machine and simultaneously a precisely timed and rated DC current is injected into the motor stator. The resultant powerful magnetic field generates an efficient braking force, without any possible damage to the motor. The DC current is disconnected when the motor comes to rest. The brake may be actuated by various switching devices, the standard method being a telescopic probe switch mounted adjacent to the spindle.

Coolant System

A compact and efficient unit comprising, tank, pump and fittings for single or multiple outlets. The tank incorporates a weir for swarf separation.

Standard equipment includes, Thermal overload push button starter for separate mounting, mounting bracket and main stopcock with segmented adjustable hose and nozzle.



TECHNICAL DATA

Tank capacity	15 Litres
Pump delivery rate	20 Litres/min @ 1.5m head
Tank width	260 mm
Tank length	430 mm
Tank height	180 mm
Overall height (Inc motor)	345 mm
Motor	1ph 230v 50Hz 0.6a 0.11kW 3ph 400v 50Hz 0.3a 0.11kW
Segmented hose / nozzle	Length 450 mm
Delivery hose	Length 1524 mm Bore 9.5 mm
Return hose	Length 1067 mm Bore 12.7 mm

Chucks, Arbors & Reducing Sleeves

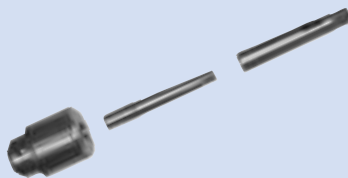

A range of chucks, arbors and reducing sleeves for use on all drilling machines fitted with morse taper spindles.

CHUCKS		ARBORS	REDUCING SLEEVES
0 - 1/2"	0 - 13 mm	No 1 MT	No 2 to No 1 MT
1/8" - 5/8"	3 - 16 mm	No 2 MT	No 3 to No 2 MT
3/16" - 3/4"	5 - 19 mm	No 3 MT	No 4 to No 3 MT
		No 4 MT	



Morse Taper Drifts

Spare Morse Taper Drifts for easy MT drill or chuck changing. Machined, air hardened and black coated special steel ejecting drifts. 1 - 2 MT or 3 - 4 MT.

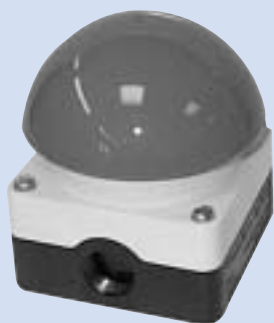

Trailing Lead Foot Stop Switch

A useful additional device for bench mounted machines, essential for applications where both hands are being used during the work cycle.

Drill Guards

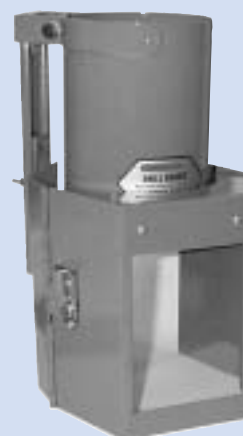

CLAMP Dia	PART No	FITS MEDDINGS MACHINE
64 mm 2 1/2"	10 - 19455	Standard (Driltru, L1, L2, M2 & M4)
90 mm 3 1/2"	10 - 19456	Standard (M5, Mk III)
76 mm 3"	10 - 19458	Standard (S68, CS30, S32M)
95 mm 3 3/4"	10 - 19843	Standard (M5 Mk III)
95 mm 3 3/4"	10 - 20401	Standard (S28, S28M, S30, S32ME, AZ32V, X Series)
76 mm 3"	10 - 20355	Heavy Duty (28TR)
80 mm 3 1/8"	10 - 20356	Heavy Duty (35TR)
105 mm 4 1/8"	10 - 20357	Heavy Duty (35ATR)
82 mm 3 1/4"	10 - 20478	Heavy Duty (S/A/B32)
92 mm 3 5/8"	10 - 20479	Heavy Duty (S/A/B35)
96 mm 3 3/4"	10 - 20480	Heavy Duty (A/B 40 - 45 - 45 - 50)

Meddings drill guards are designed to meet current stringent PUWER requirements for safety.

Standard and Heavy Duty guards have an upper shroud cover incorporating the quill clamping ring with a rigid slideway having ball tracks connecting to the guard lower skirt. This gives the guard vertical movement when in use, providing maximum coverage of the rotating chuck and drill bit. The perspex viewing screen gives visibility and a hinged door system provides tool access.

Replacement Screens for Drill Guards

Packs of 3 off. Complete with fixings and instructions.

GUARD Ref.	3 x Screen Part No.
For Standard Drill Guards 19455	10 - 20657
19458	10 - 20658
19456 & 19843	10 - 20659
20401	10 - 20660
For all Heavy Duty Guards	10 - 20661

