

ABEL HP/HPT

From the reciprocating positive
displacement pump specialist



**High Pressure Pumps.
An efficient, solid purchase.**

ABEL HP - Performance range: up to 25 m³/h (110 GPM) and 16.0 MPa (2,300 psi)

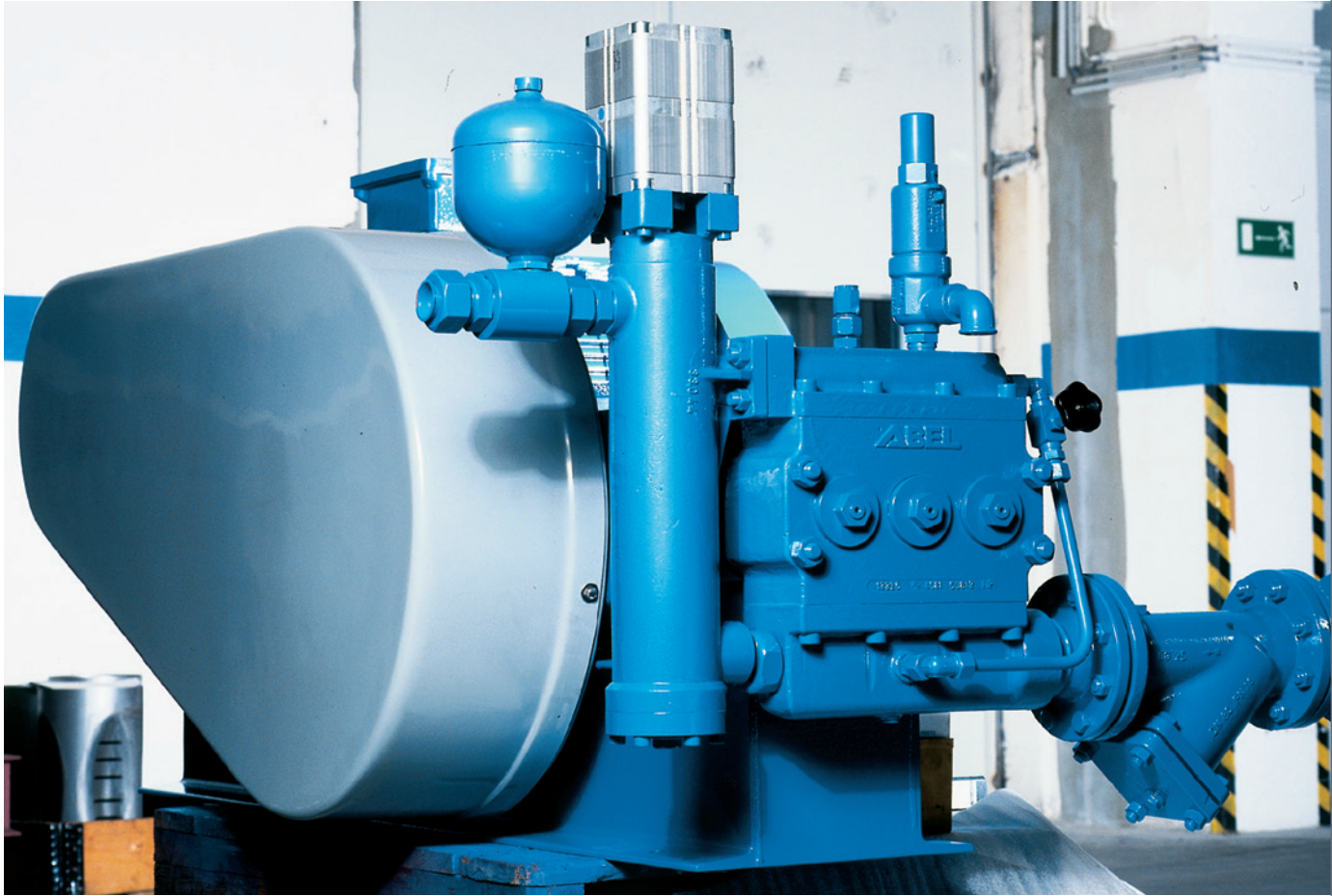

The first choice of leading filter press manufacturers: ABEL HP for filter cloth washing

THE EFFICIENT, SOLID PURCHASE: ABEL HP. For high pressure cleaning applications up to 16.0 MPa (2,300 psi) ABEL offers their clients a triplex plunger pump series which has proven its worth many times over, especially when used to clean filter cloths for chamber and membrane filter presses.

With accessories that are designed to meet the specific needs of cleaning applications, such as the ABEL 3/2-way bypass valve, this series lives up to expectations. The ABEL HP series pumps can be used in the oil and gas industries, and for feeding combiners in the food industry.



Pneumatically actuated 3/2-way bypass valve for filter cloth wash pumps

ABEL HPT - Performance range: up to 80 m³/h (350 GPM) and 25.0 MPa (3,625 psi)



ABEL HPT for injection of oily brine water for gas extraction

VERY HIGH PRESSURE FOR AN EXTENDED PERIOD OF TIME – IS DEMANDING – REQUIRES: ABEL HPT.

Especially in process technology, ABEL HPT high pressure plunger pumps show a technological edge when used rigorously over a longer period of time. And that applies for quite varied media, such as salt water and salt solutions, acids, margarine, chemicals, and even lightly contaminated fluids.

Designed to meet the requirements of the media being pumped, various materials are used, such as high quality stainless steel. Different types of valves are also used, such as cone, spherical cone, and ball valves. The plunger seal, which is adapted to meet the requirements of the application and pumping media, is made using V-rings or stuffing boxes with flushed or lubricated versions available if required.

Built in mobile turnkey containers, HPT series pumps can be used in a number of applications, especially when you require a high degree of mobility because you need to keep changing locations.



ABEL HPT as ready-to-use, mobile container pump.

Applications of ABEL high pressure pumps

Cleaning:

- filter cloths
- tanks and containers
- pipes

Feeding:

- gas washers and gas dryers
- reverse osmosis systems
- reactors
- high pressure injection on gas and oil fields
- combinator for margarine production

ABEL high-pressure pumps are single-acting plunger pumps. Large valve cross-sections ensure uniform, low pulsation running. The slow and very smooth running crank drive is lubricated by a splash oil system. Oil deflector plates ensure optimal lubrication of the important bearing points, even at particularly low speeds.

The power train consists of an AC motor which is connected to the crankshaft by a v-belt drive and/or a reduction gear.

The HPT bellow-type seals of the crossheads offer an optimal protection against the penetration of dust into the crank housing. The plungers are available in high quality stainless steels, hardened, chromium oxide coated or made of solid ceramics.



Our high pressure plunger pumps are also available with ATEX certification for our customers in the chemical and petrochemical industries.



ABEL HP for filter cloth washing



ABEL High Pressure Pump for injection of ethylene in gas drying process

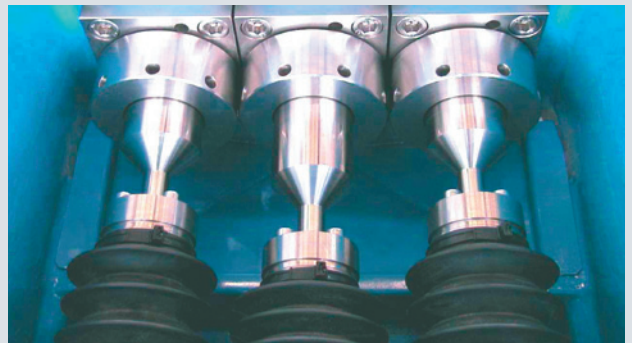

The bellow-type seal of the ABEL HPT pump reliably protects the gear against contamination by dirt and fluids



Matched to the application – various plunger materials

**Optimum design – Strong and tough,
to match the medium**

Optional accessories

- discharge side safety valve
- pulsation dampener
- suction/discharge side pressure gauges
- shock absorbing installation
- sound control cabins and many others

Your product determines the housing material: nodular cast iron and stainless steel casting are available as well as specialty bronzes. Depending on application and pressure range, forged materials are used.

Adapted to the pumping media:

- clean liquids
- abrasive media
- shear-sensitive and dwell-critical fluids
- plate type, cone and ball valves are available

When intermittent operation is required, the pneumatically operated ABEL bypass valve ensures trouble-free interruption of the flow. Hydraulically operated bypass valves may also be used.

Different solutions matched with the product ensure the plunger sealing!

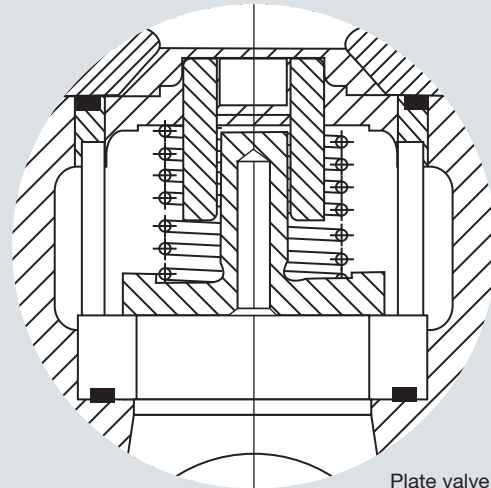
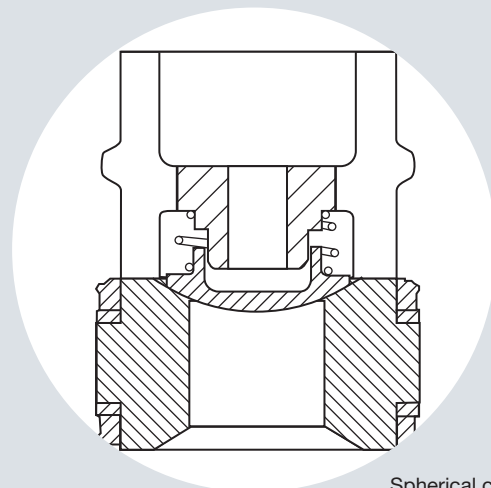
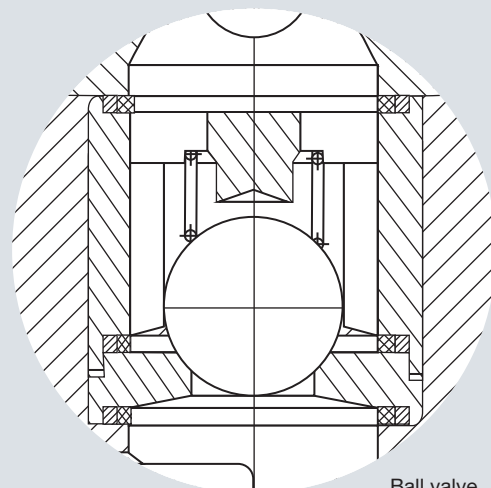

Plate valve



Spherical cone valve



Ball valve



Plate valve of the HP series for low viscous, clean media.



Membrane Pumps
Solids Handling Pumps
High Pressure Pumps
Marine Pumps

For North America

ABEL Pumps L.P.
79 N. Industrial Park, Overlook Drive
Sewickley, PA 15143-2339, USA
Phone +1 (412) 741 3222
Fax +1 (412) 741 2599
mail@abelpumps.com

For Spain, Portugal, Central and South America

ABEL Equipos S.A.
C/Anochecer 2, Edificio el Torreón
28223 Pozuelo de Alarcón, Spain
Phone +34 (91) 715 4848
Fax +34 (91) 799 0017
mail@abelequipos.es

ABEL GmbH & Co. KG
Abel-Twiete 1
D - 21514 Büchen, Germany

Phone +49 (4155) 818-0
Fax +49 (4155) 818-499
mail@abel.de • www.abel.de