

INDUSTRIAL CRANES  
NUCLEAR CRANES  
**PORT CRANES**  
HEAVY-DUTY LIFT TRUCKS  
SERVICE  
MACHINE TOOL SERVICE

**CONTAINER HANDLING**

**KONECRANES**<sup>®</sup>  
Lifting Businesses<sup>™</sup>

# Konecranes BOXRUNNER THE AGILE, MULTI-PURPOSE STRADDLE CARRIER



# Konecranes BOXRUNNER GREAT PERFORMANCE IN BLACK AND WHITE

The new Konecranes BOXRUNNER straddle carrier offers unique container handling performance to two distinct container handling operations.

## **Container handling as core business**

If you are a large container terminal operator that is adopting automation technology for greater efficiency, BOXRUNNER is the flexible link between ship-to-shore (STS) cranes and yard stacking cranes. A short and fast machine, BOXRUNNER has the speed and agility to keep containers flowing between the STSs and yard container stacks, enabling fast ship turn-around times. It can also load and unload trucks since it stacks two-high.

## **Container handling as non-core business**

If your company handles incoming and outgoing materials in containers—using trucks and trailers, stationary gantry cranes or other solutions—BOXRUNNER can be a much more effective solution.





Model	BOXRUNNER DE52	BOXRUNNER DE42
Operation	Quayside to yard container carrying	Quayside to yard container carrying
Wheels	6	6
Stacking height	1 over 1	1 over 1
Spreader	Twin	Single
Safe Working Load	50 tons	40 tons

# ASK YOUR DRIVER

Your driver's productivity and job satisfaction are greatly affected by the safety and comfort of his machine and his ability to control it. BOXRUNNER's cabin affords excellent visibility in all directions—reducing the risk of blind spots. The machine is built around a uniquely rigid steel structure which provides a very stable and safe drive experience. Your driver can control the machine precisely, aided by simple controls and intelligent displays that are ergonomically arranged according to your requirements.

In straight driving, the machine's multi-axle steering system provides a particularly stable feel. When driving straight at high speed or when turning, the steering system shifts to Truck Steering Mode—now only the front wheels are used for steering.

Vibration to the driver's body is minimized by the combination of effective vehicle and seat suspension. The drive system and cab are thoroughly sound-proofed to minimize noise. Last but not least, the driver can precisely control the cab climate in all weather.

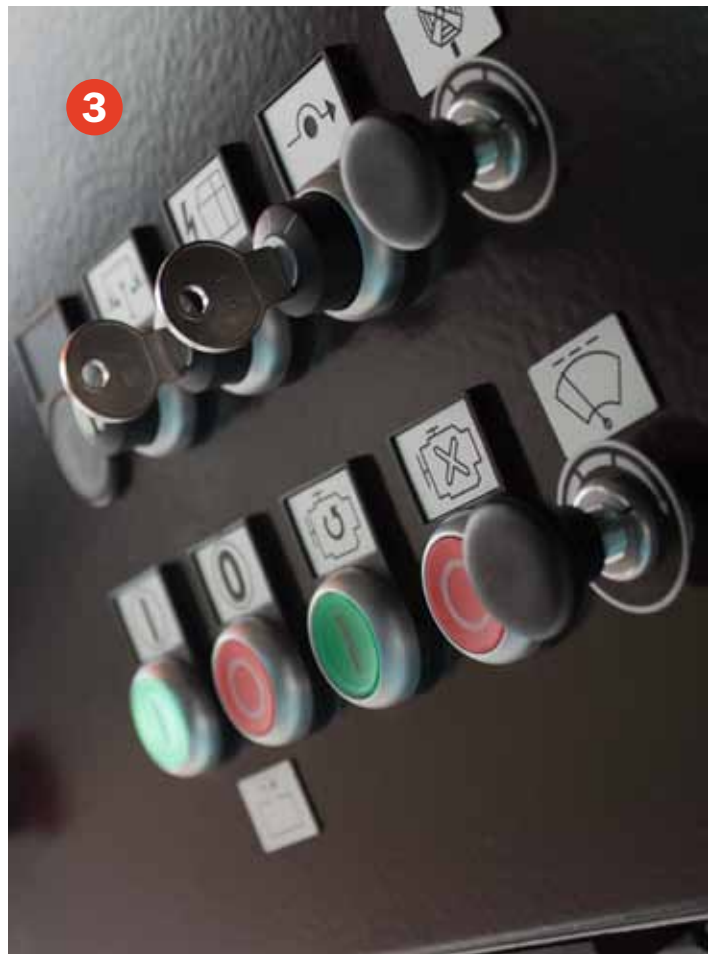



1. Adjustable pedal length and angle
2. Height and angle of steering column can be adjusted
3. Controls and seating customized to your requirements



## Steering system

# A STRONG SENSE OF CONTROL

BOXRUNNER's electronic-hydraulic steering system provides a strong sense of control over the machine in contact with the drive surface and the containers it handles. The steering system aligns the wheels precisely, ensuring directional stability and reducing tire wear. Each wheel is turned by a differential cylinder with an integrated stroke sensor, eliminating slackness and backlash.

The BOXRUNNER's steering system has a low requirement for maintenance and spare parts. The steering cylinders and rods are well-protected against collision and contamination.

### SMARTER WHERE IT MATTERS

BOXRUNNER's steering system is intelligent. When driving slowly and when maneuvering in curves, the system moves all the axles to provide maximum agility. When driving at high speed and on straight-aways, the system shifts to "Truck Steering Mode", in which only the front wheels are used for steering. This mode provides a very stable feel on straight tracks.



1. Steering cylinder (one at each corner)
2. Short, identical steering rods
3. Safety cover
4. Safety device: quick-change shear bolts in case of accident

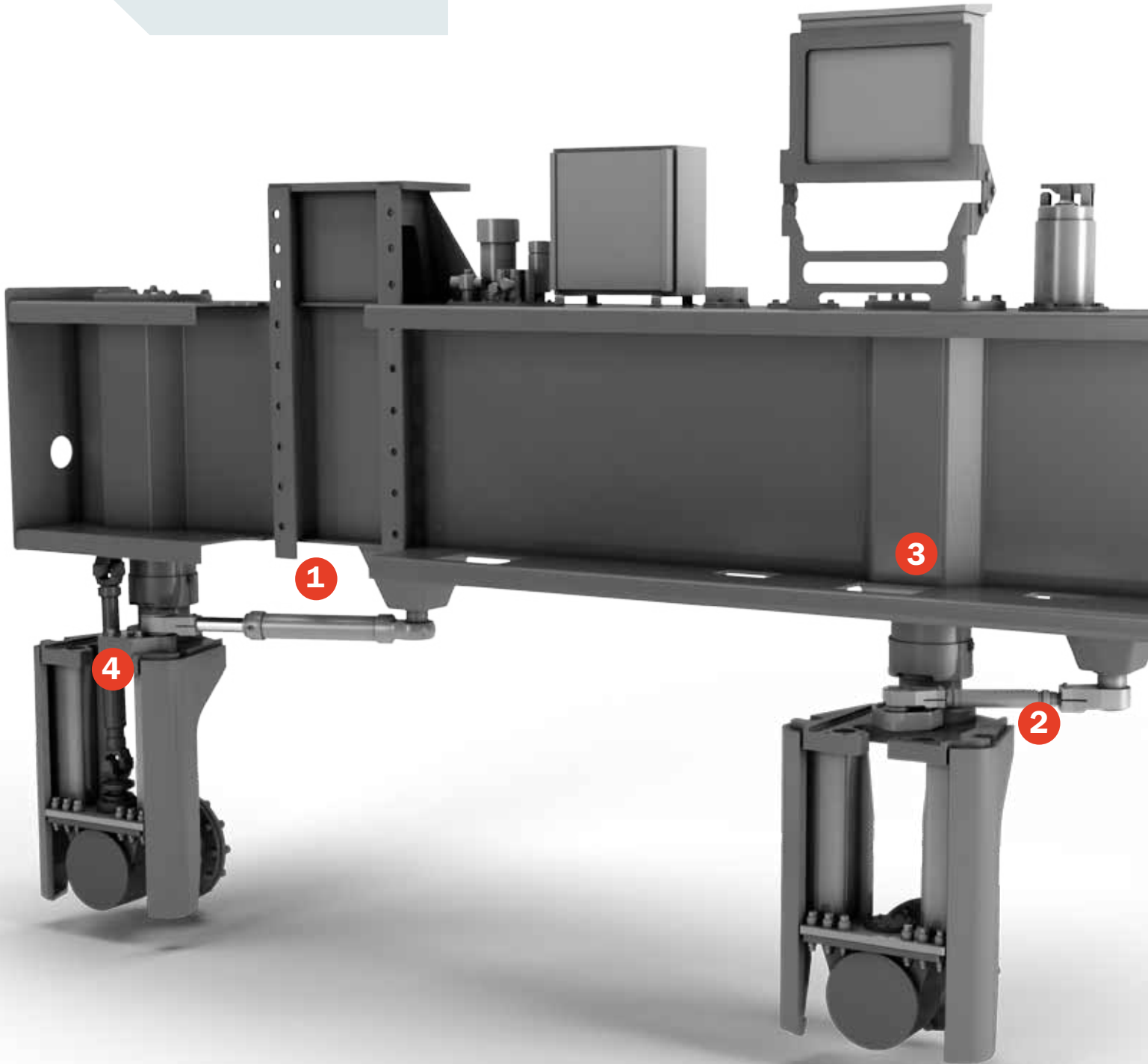





## Suspension system

# A WORLD-CLASS RIDE

BOXRUNNER's chassis is equipped with six independently suspended wheels, each with its own maintenance-free suspension assembly. The design of the suspension assembly is based on a special alignment of spring elements and bearings that effectively controls rod movement during driving and braking, ensuring excellent stability in all driving situations.

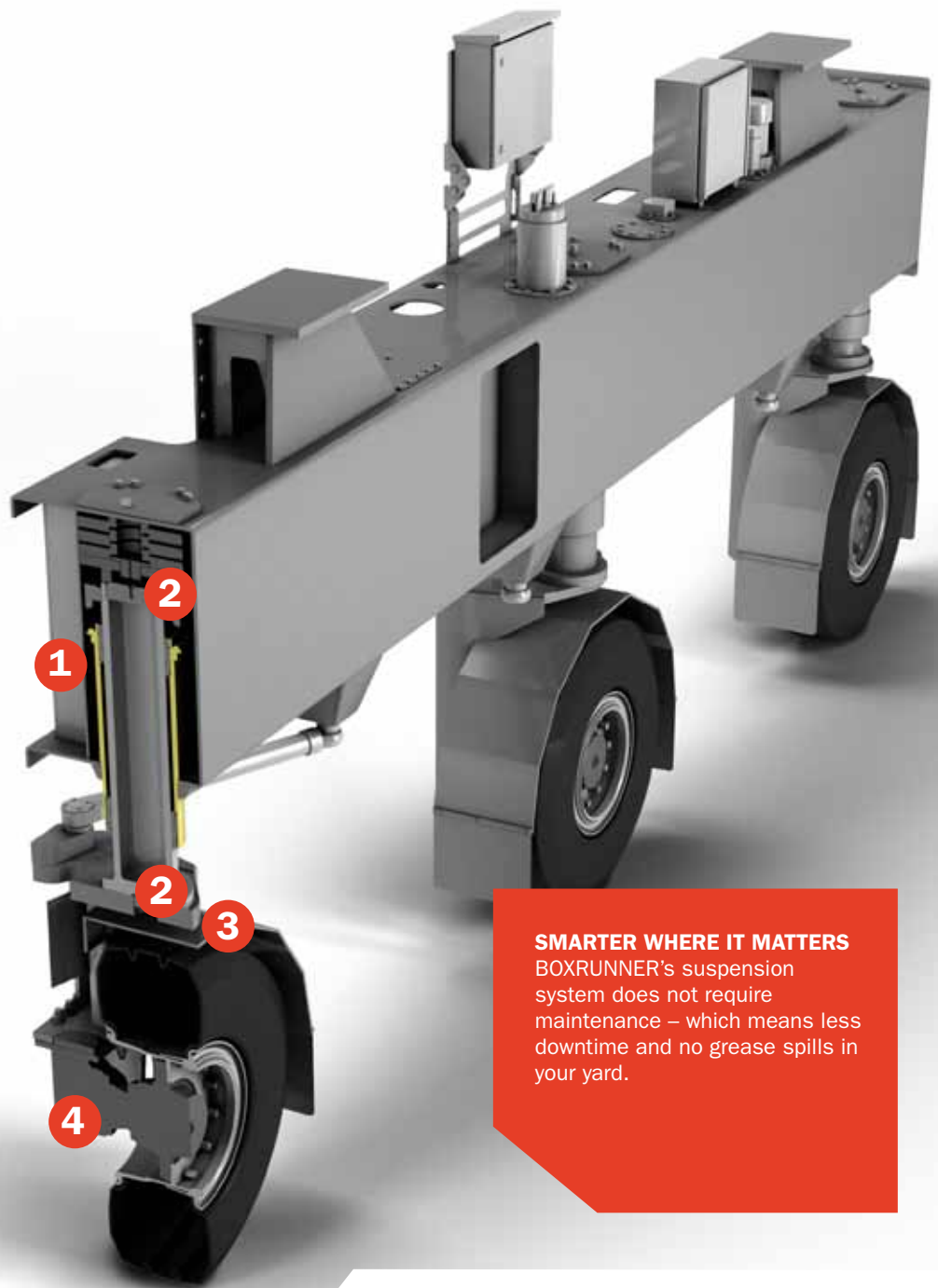

1. Elastomer suspension and clamping units
2. Polymer compound bearing/ Teflon bearing
3. Hard-coated pivot pin
4. Gear drive

**SMARTER WHERE IT MATTERS**  
BOXRUNNER's suspension system does not require maintenance – which means less downtime and no grease spills in your yard.

# HOISTING SYSTEM

The hoist motors, rope drums and gear boxes of the BOXRUNNER hoisting system are designed and manufactured by Konecranes in-house. This is how we ensure they work together flawlessly, in true balance with the lifting work they do. The BOXRUNNER's hoisting system is well-known and field-proven in Konecranes Rubber Tired Gantry (RTG) and Rail Mounted Gantry (RMG) cranes, used by the world's most demanding container terminal operators.

The BOXRUNNER's hoisting system offers a reliable lifting capacity of 50 metric tons Safe Working Load under spreader. The yoke beam is very rigid. If a collision occurs, the force is transferred to special bolts that break in a controlled manner, reducing the extent of the damage and downtime.

The rope pulleys are positioned at 90° to the yoke beam to give the driver a clear field of vision. Maintenance-friendly design features include how the hoisting system is positioned on the machinery platform for easy access, and how the main parts of the yoke beams slide for easy access.





**SMARTER WHERE IT MATTERS**

1. Konecranes hoist motor
2. Konecranes hoist rope drum
3. Konecranes hoist gear box
4. Wire rope cover
5. Rope length adjuster
6. Yoke beam
7. Rope pulley, 90° to yoke beam

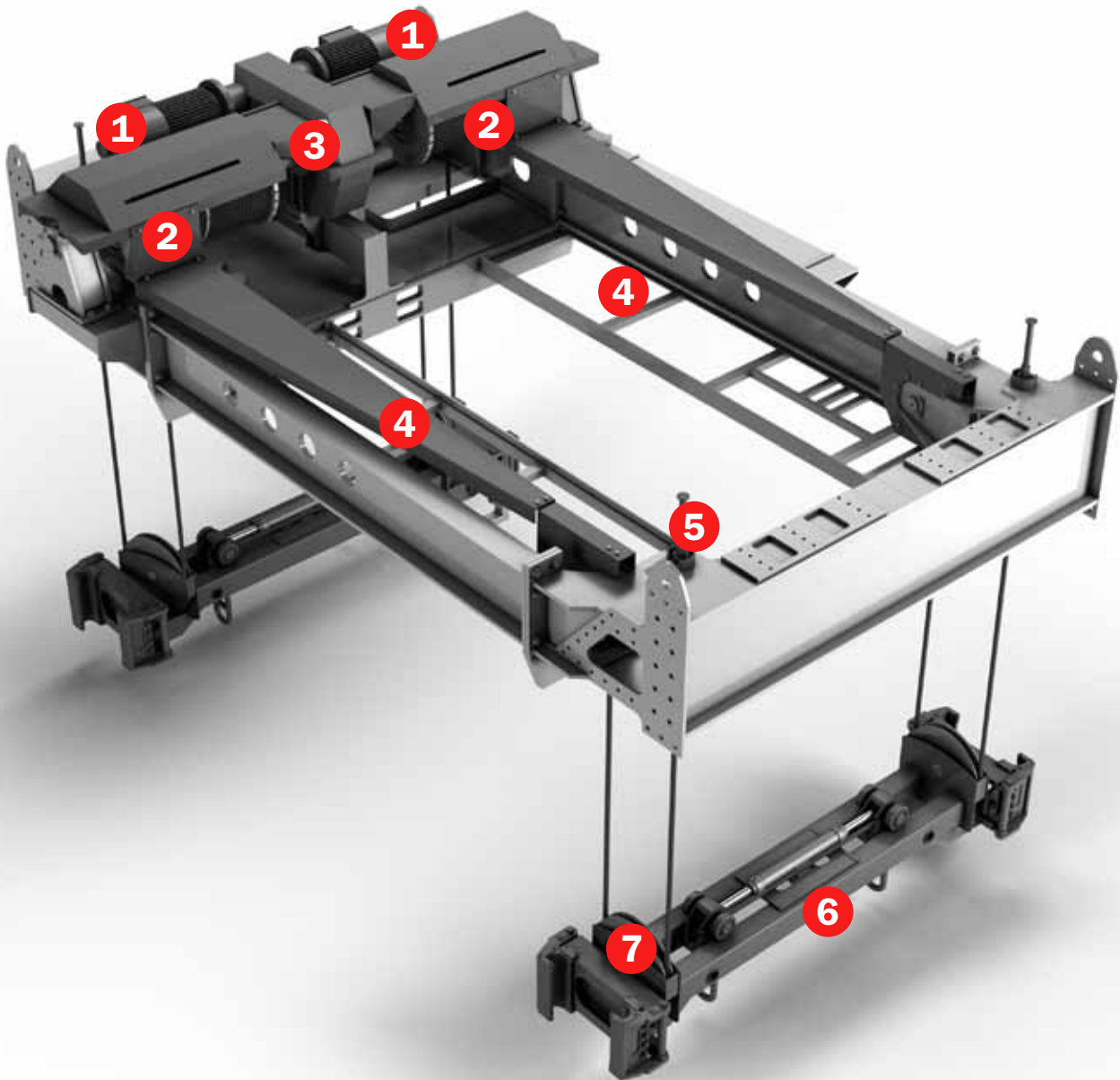

# BORN TO LIFT

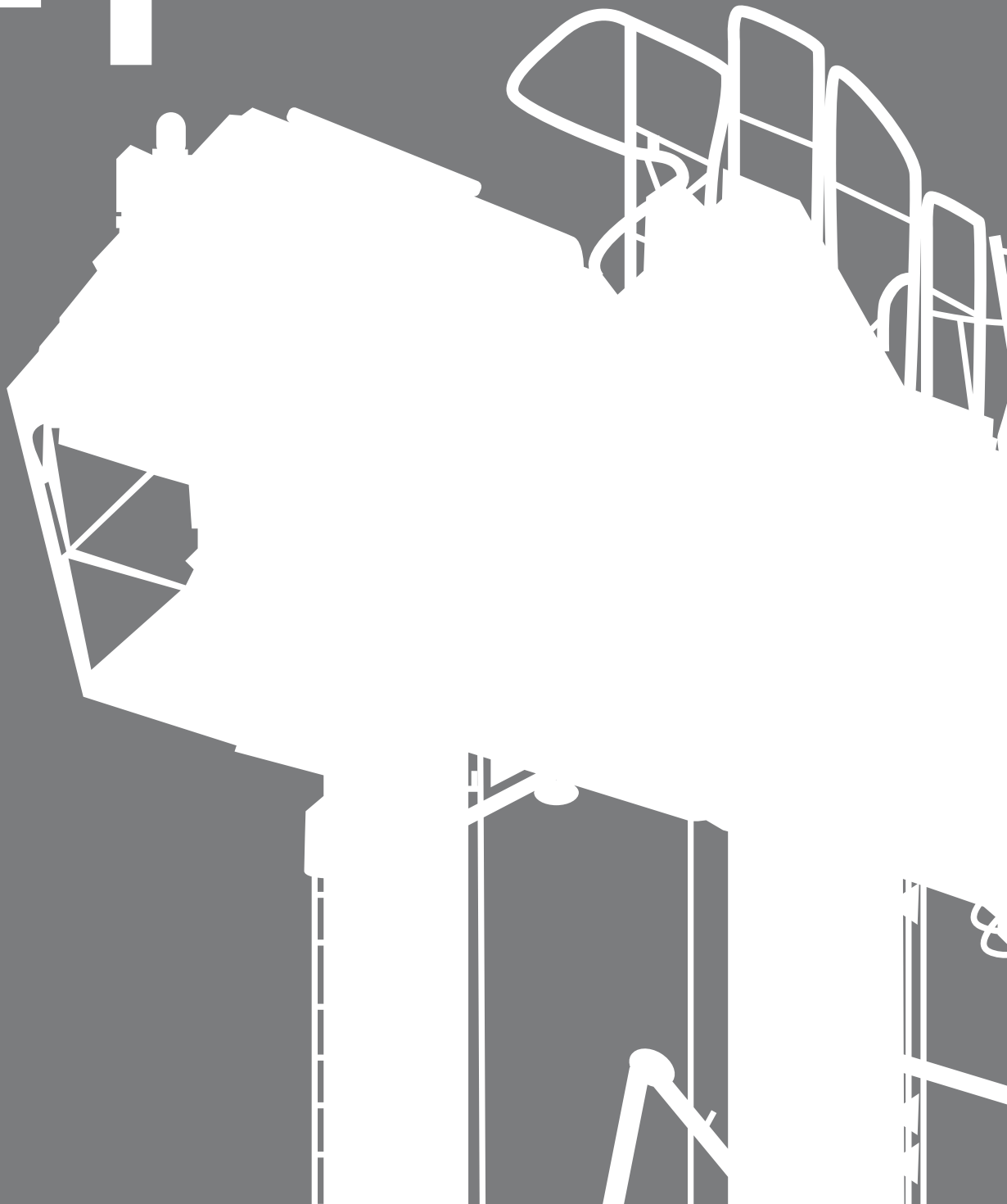

**Customer:**  
**Inter Ferry Boats (IFB)**

# SMART MACHINES AND FULL SERVICE

In 2009, the Belgian multimodal cargo service provider Inter Ferry Boats (IFB) chose Konecranes straddle carriers for its main hub terminal in the port of Antwerp. The deal clincher was the combination of smart machines and full service that Konecranes could provide.

Konecranes delivered nine Konecranes DE54 straddle carriers that have proved to be up to the challenge of IFB's business. The DE54s have a lifting capacity of 50 metric tons. They can stack containers up to 4 high, and handle all sea transport ISO containers from 6 to 13.7 meters in length.

A Konecranes straddle carrier is designed to require less maintenance than conventional machines, but the proof is in the performance over time. A Konecranes site supervisor is dedicated to IFB to keep the machines running without unexpected downtime. Konecranes carries out regular preventive maintenance as part of a maintenance contract with IFB. The contract provides clear operative and financial benefits including lengthening of the machines' operating life and optimization of the service workflow.



“ Konecranes had the best design, a good financial offer and a solid maintenance contract. Just what we were looking for. ”

Johan Gemels  
General Manager, IFB Terminals



**Minimize downtime cost**

# MAXIMIZE UPTIME VALUE

## What's the real cost of your equipment?

The original purchase price is just the tip of the cost iceberg over the lifetime of a straddle carrier. While some operational costs are quite fixed, costs related to scheduled and on-call maintenance, spare parts and modernization can be wisely controlled with Konecranes services. The result is a lower cost, spread over the lifetime of the straddle carrier.



## Just the service you need

Konecranes can provide you with the right package of services, from routine maintenance to a sophisticated preventive and predictive maintenance program, from occasional emergency repairs to an all-inclusive maintenance agreement with availability guarantees. Our mutual goal is a very efficient, highly profitable straddle carrier operation that provides plenty of scope for growth.

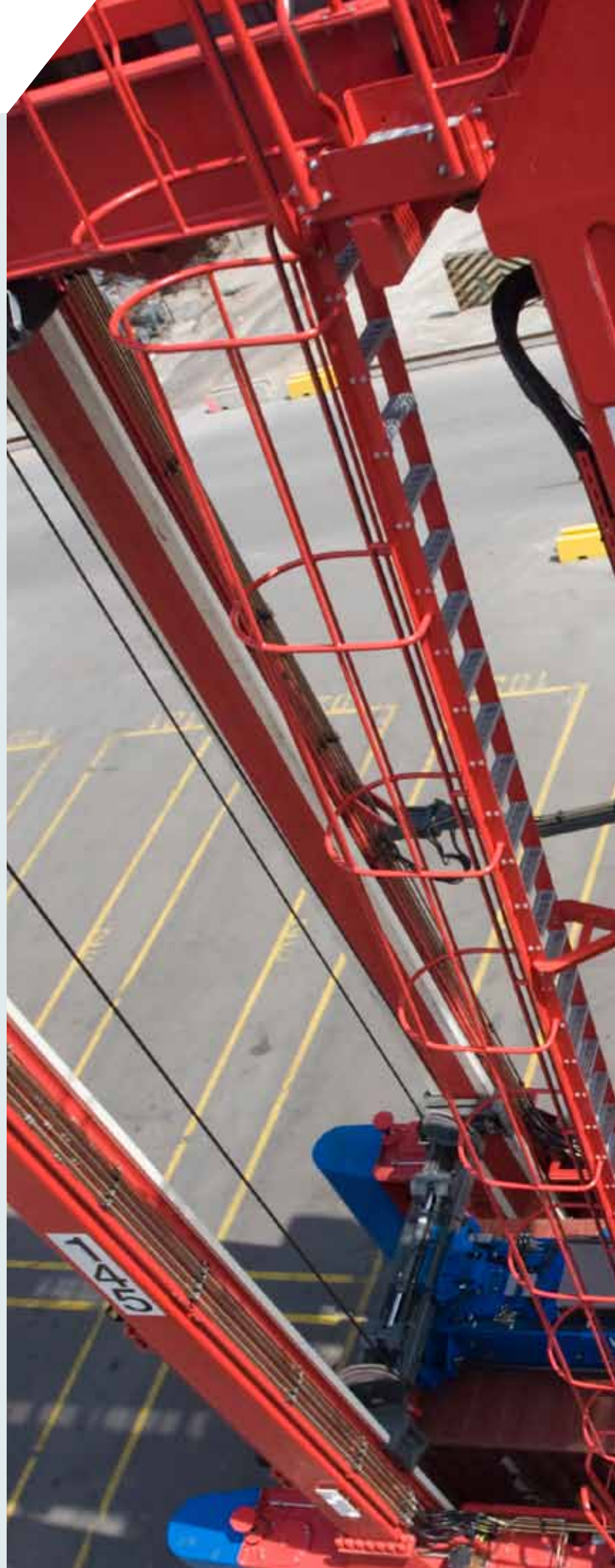





## Konecranes BOXRUNNER DE52

Max. dimensions	Diesel-electric
Safe working load under spreader, tons: single/twin	40/50
Exceptional load under spreader	60
Lifting height under spreader with load/min. pick-up height, mm	6200/300
Overall height unloaded, mm	10100
Frame overall width without rubbing bars, mm	4940
Frame inside clearance without rubbing bars, mm	3500
Turning radius inside/outside without bumpers, mm	3700/9600
Service weight, tons	57
Wheel load with 40-ton load	16.2

Spreader	Single 20-40 ft & 45 ft in 40 ft castings
Special	Single, twin, long twin
Spreader side shift/swivel	±280 mm / ±6°

Max. speeds	Diesel-electric
Traveling speed empty/with load, km/h	30/26 km/h
Lifting speed empty/40/50/ ton loads, m/min	24/20/18 m/min
Lowering speed empty/with load, m/min	22/18 m/min

Power unit	330 kW rated power output
Diesel engine displacement, liters	12
Variable speed control diesel engine, rpm	800 - 1800
Environmental specification	EURO 2/3a/3b respective Tier 2/3/4i available
Tank capacity, liters	2 x 875

Misc.	
Tires	6 x 480/95 R25 or optional 16.00 R25
Service brakes	4 x wet disc with oil cooling
Parking brakes	4 x spring-activated wet disc
PLC and bus systems	Siemens S 7 300 mobile/Profibus





**MAXIMIZING  
THE PRODUCTIVITY  
OF UPTIME**

**KONECRANES®**  
Lifting Businesses™

**HIGHEST LIFECYCLE VALUE**

**CUSTOMER VALUE SPREAD**

**INDUSTRY  
SHARPER  
FOCUS**

**MINIMIZING  
THE COST OF  
DOWNTIME**

**GENERAL  
INDUSTRY  
FOCUS**

**145**



INDUSTRIAL  
CRANES



NUCLEAR  
CRANES



PORT  
CRANES



HEAVY-DUTY  
LIFT TRUCKS



SERVICE



MACHINE  
TOOL  
SERVICE



Konecranes is a world-leading group of Lifting Businesses™ offering lifting equipment and services that improve productivity in a wide variety of industries. The company is listed on NASDAQ OMX Helsinki Ltd (symbol: KCR1V). With over 10,000 employees at more than 550 locations in almost 50 countries we have the resources, technology and determination to deliver on the promise of Lifting Businesses™.

© 2011 Konecranes. All rights reserved. "Konecranes", "Lifting Businesses" and  are registered trademarks of Konecranes.



**Konecranes** P.O. BOX 661 Koneenkatu 8 FI-05801 Hyvinkää  
Tel +358-(0)20 427 2043 Fax +358-(0)20 427 2103 [www.konecranes.com](http://www.konecranes.com)