

SERVICE
MACHINE TOOL SERVICE
LIGHT LIFTING
INDUSTRIAL CRANES
PROCESS CRANES
PORT CRANES
LIFT TRUCKS
YARD IT

AutoSteering

KONECRANES[®]
Lifting Businesses[™]

Always on the right track **AUTOSTEERING FOR RTG CRANES**

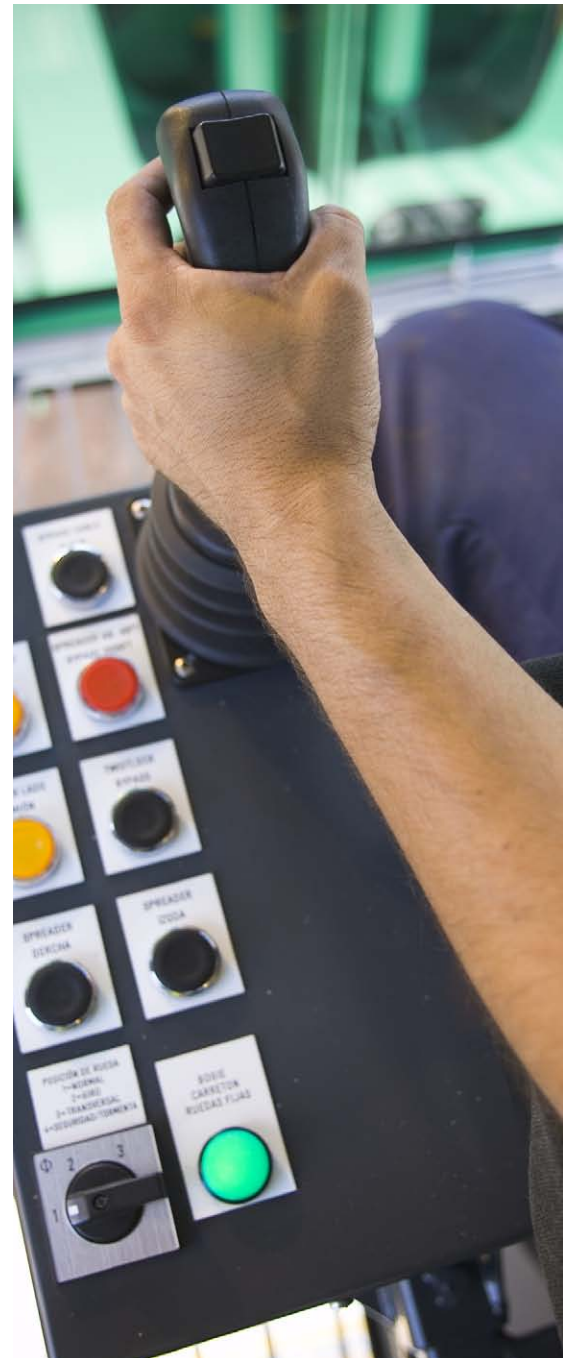

SAFETY THROUGH ACCURACY

The YardIT AutoSteering module is designed to be the backbone in a series of modular automation tools for RTGs.

Konecranes RTG autosteering delivers a range of decisive advantages, including improved worker safety and increased driver productivity. It keeps the RTG gantry on a pre-programmed path without driver steering inputs, allowing your driver to stay focused on other tasks. More precise steering means a more precisely optimized stack alignment that permits greater stack density and also helps prevent collisions caused by loose, unpredicted configurations.

Konecranes has the RAAS feature ("Shadow-support") built into the AutoSteering-package. In practice the two-antenna solution means that the position/direction of the crane is not lost even if one of the antennae temporarily loses satellite connection due, for example, to a large obstacle such as an STS crane or building. RAAS is Konecranes' own patented GPS-calculation feature (ReAcquisition Accelerator System) and is exclusive to Konecranes.

The main features of the AutoSteering module are:

- Twin dual-frequency DGPS receiver for accuracy and redundancy
- Dual DGPS receiver antennas on the opposite ends of the gantry for accurate heading determination
- Full integration to PLC systems, including AC drive encoders
- Graphical deviation display in the operator cabin
- Automatic slow-down/fast ramp-down in the event of excessive deviation

Geometric superiority of the two-antenna solution vs the one-antenna solution

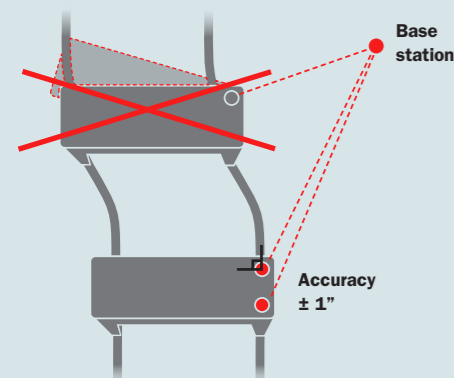

Konecranes has over 200 AutoSteering modules already successfully installed in Konecranes RTGs.



EFFICIENCY AT EVERY TURN

The AutoSteering module offers a clean upgrade path for further RTG automation. Key steps to full automation are:

- **AutoStop** – automatically stops the gantry and trolley travel when a target container slot is reached. This allows for full speed motion until deceleration is automatically initiated. Optimizing the deceleration profile and timing through a programmed ramp decreases the RTG cycle time.
- **AutoMove** – enables fully automatic operation of RTG gantry and trolley. When a target container slot is transmitted to the RTG, the spreader automatically moves on top of the target slot. Hoisting (both up and down) is semi-automatic.
- **AutoGrab** – enables the RTG to perform the final movement of the spreader grabbing container fully automatically.
- **TeleMove module** – allows a single operator to operate several RTGs in teleoperation. Gantry and trolley travel are fully automatic, whereas the final hoist-lowering, micromotions, lock/unlock functions and initial hoist lift are performed manually through a teleoperation station. The remotely located operator receives video feed from the RTG and operates the RTG with controls similar to a regular RTG cabin.

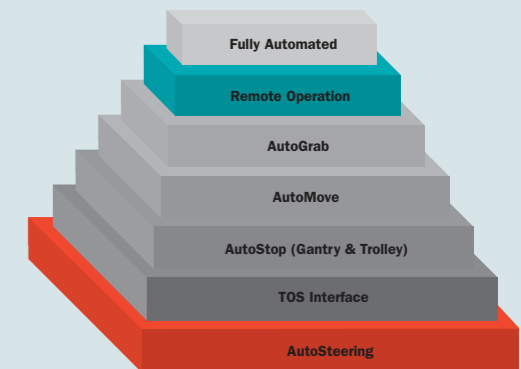

- Step-by-step automation for container operators
- Safe operation
- Does not interfere with daily operations
- Minimal labour issues
- Reasonable costs
- Utilizes existing investments

This publication is for general informational purposes only. Konecranes reserves the right at any time, without notice, to alter or discontinue the products and/or specifications referenced herein. This publication creates no warranty on the part of Konecranes, express or implied, including but not limited to any implied warranty of merchantability or fitness for a particular purpose.



SERVICE



MACHINE
TOOL
SERVICE



LIGHT
LIFTING



INDUSTRIAL
CRANES



PROCESS
CRANES



PORT
CRANES



LIFT
TRUCKS



YARD IT



Konecranes is a world-leading group of Lifting Businesses, serving a broad range of customers, including manufacturing and process industries, shipyards, ports and terminals. Konecranes provides productivity-enhancing lifting solutions as well as services for lifting equipment and machine tools of all makes. In 2008, Group sales totaled EUR 2,103 million. The Group has 9,900 employees, at more than 485 locations in 43 countries. Konecranes is listed on the NASDAQ OMX Helsinki Ltd (symbol: KCR1V).

© 2009 Konecranes. All rights reserved. 'Konecranes', 'Lifting Businesses' and  are registered trademarks of Konecranes.



www.konecranes.com