

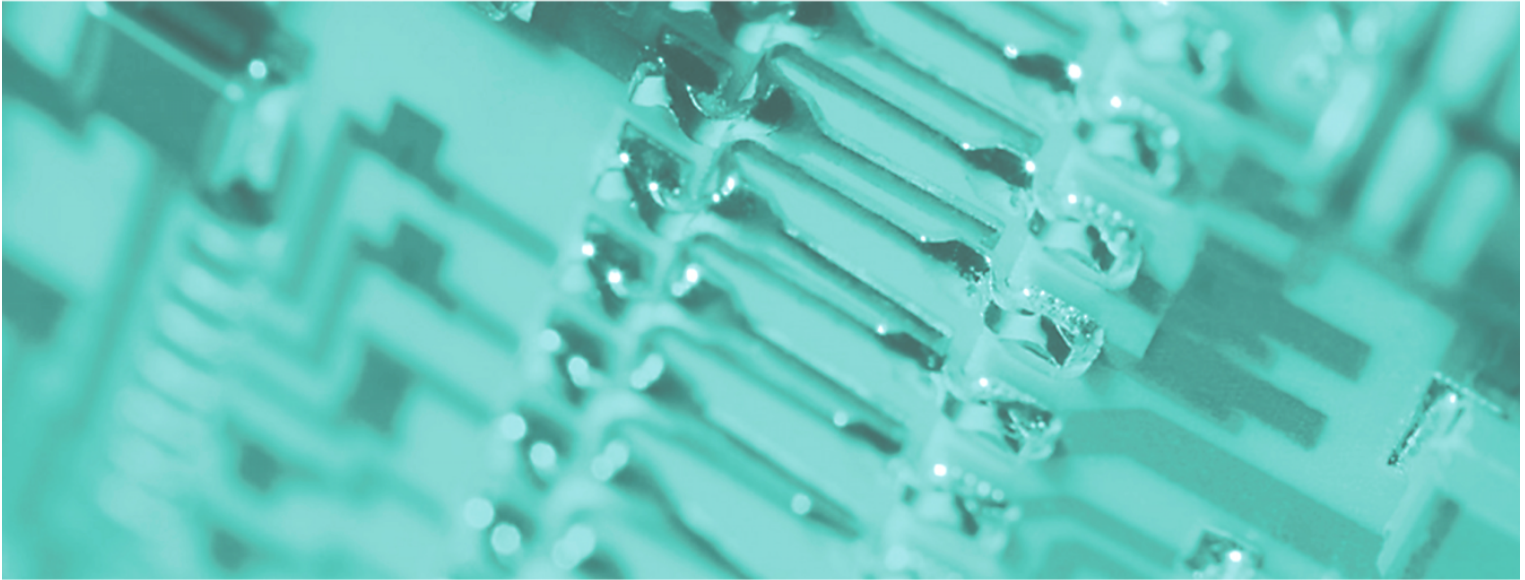

VIPA HMI



Commander Compact | CC 03 | Manual

HB116E_CC03 | Rev. 11/41

October 2011

Copyright © VIPA GmbH. All Rights Reserved.

This document contains proprietary information of VIPA and is not to be disclosed or used except in accordance with applicable agreements.

This material is protected by the copyright laws. It may not be reproduced, distributed, or altered in any fashion by any entity (either internal or external to VIPA), except in accordance with applicable agreements, contracts or licensing, without the express written consent of VIPA and the business management owner of the material.

For permission to reproduce or distribute, please contact:
VIPA, Gesellschaft für Visualisierung und Prozessautomatisierung mbH
Ohmstraße 4, D-91074 Herzogenaurach, Germany
Tel.: +49 (91 32) 744 -0
Fax.: +49 9132 744 1864
EMail: info@vipa.de
<http://www.vipa.de>

Note

Every effort has been made to ensure that the information contained in this document was complete and accurate at the time of publishing. Nevertheless, the authors retain the right to modify the information. This customer document describes all the hardware units and functions known at the present time. Descriptions may be included for units which are not present at the customer site. The exact scope of delivery is described in the respective purchase contract.

CE Conformity

Hereby, VIPA GmbH declares that the products and systems are in compliance with the essential requirements and other relevant provisions of the following directives:

- 2004/108/EC Electromagnetic Compatibility Directive
- 2006/95/EC Low Voltage Directive

Conformity is indicated by the CE marking affixed to the product.

Conformity Information

For more information regarding CE marking and Declaration of Conformity (DoC), please contact your local VIPA customer service organization.

Trademarks

VIPA, SLIO, System 100V, System 200V, System 300V, System 300S, System 400V, System 500S and Commander Compact are registered trademarks of VIPA Gesellschaft für Visualisierung und Prozessautomatisierung mbH.

SPEED7 is a registered trademark of profichip GmbH.

SIMATIC, STEP, SINEC, S7-300 and S7-400 are registered trademarks of Siemens AG.

Microsoft und Windows are registered trademarks of Microsoft Inc., USA.

Portable Document Format (PDF) and Postscript are registered trademarks of Adobe Systems, Inc.

All other trademarks, logos and service or product marks specified herein are owned by their respective companies.

Information product support

Contact your local VIPA Customer Service Organization representative if you wish to report errors or questions regarding the contents of this document. If you are unable to locate a customer service center, contact VIPA as follows:

VIPA GmbH, Ohmstraße 4, 91074 Herzogenaurach, Germany

Telefax: +49 9132 744 1204
EMail: documentation@vipa.de

Technical support

Contact your local VIPA Customer Service Organization representative if you encounter problems with the product or have questions regarding the product. If you are unable to locate a customer service center, contact VIPA as follows:

VIPA GmbH, Ohmstraße 4, 91074 Herzogenaurach, Germany

Telephone: +49 9132 744 1150/1180 (Hotline)
EMail: support@vipa.de

Contents

About this Manual	1
Safety informations	2
Chapter 1 Hardware description	1-1
Safety information for Users	1-2
Properties	1-4
Structure	1-5
Components	1-6
Dimensions	1-11
CC-CPU - Function security	1-12
Technical data	1-13
Chapter 2 Deployment CC 03 - Operator panel	2-1
Fast introduction	2-2
Installation	2-6
Cabling	2-7
Project engineering operator panel	2-8
Commissioning	2-16
Deployment operator panel	2-19
Chapter 3 Deployment CC 03 - CC-CPU	3-1
Start-up behavior	3-2
Principles of the address allocation	3-3
CC-CPU - Project engineering	3-4
CC-CPU - Operating modes	3-11
CC-CPU - Overall reset	3-12
Firmware update	3-14
VIPA specific diagnostic entries	3-17
CC-CPU - Test functions	3-19
Chapter 4 Deployment CC 03DP with PROFIBUS DP	4-1
Principles	4-2
Project engineering CC 03DP	4-7
DP slave parameters	4-12
Diagnostics functions	4-15
Status message internal to CC-CPU	4-18
PROFIBUS installation guidelines	4-20
Commissioning	4-25
Chapter 5 Functions operator panel	5-1
Screens	5-2
Standard project with standard functions	5-4
Process depending operation	5-5
Messages	5-12
Timer and Counter	5-15
Operating mode	5-16
StatVAR and ForceVAR	5-17
Password protection	5-19
Chapter 6 General installation guidelines	6-1
Basic rules for the EMC-equitable assembly of installations	6-2
EMC-equitable assembly	6-6
EMC-equitable cabling	6-7
Special precautions providing high noise immunity	6-11
Checklist for the EMC-compliant installation of controllers	6-12

About this Manual

This manual describes the structure, project engineering and the handling of the Commander Compact CC 03 from VIPA.

Outline

Chapter 1: Hardware description

In this chapter the hardware components of the CC 03 are described. Besides of a description of the single components, the dimensions that are required for the installation of the CC 03 may also be found. The chapter closes with the technical data.

Please consider the safety hints at the beginning of the chapter.

Chapter 2: Deployment CC 03 - Operator panel

This chapter explains the deployment and the project engineering of the operator panel of the CC 03.

After the fast introduction there are information about the installation of the CC 03 and the configuration by the OP-Manager. This is followed by notes for commissioning. The chapter closes with a description of the operation of the panel.

Chapter 3: Deployment CC 03 - CC-CPU

This chapter includes all information required for the deployment of the CC-CPU, from the project engineering and addressing up to firmware update and commissioning.

Chapter 4: Deployment CC 03DP with PROFIBUS-DP

Content of this chapter is the deployment of the CC 03DP with PROFIBUS. It includes all information required for deploying an intelligent PROFIBUS DP slave.

Chapter 5: Functions operator panel

This chapter informs you about the functionalities of the operator panel. Especially referred to is to the functions that are part of the standard project.

The text describes how you access screens, use operating keys, react to messages, alter values and use the password protection.

Chapter 6: General installation guidelines

The chapter gives you information about the interference-free installation of Programmable Logic Controls (PLC) together with a CC 03.

Here we describe possible paths how interference can enter the controller, how you ensure the electromagnetic compatibility (EMC) and how to approach shielding and screening issues.

Objective and contents

This manual describes the Commander Compact from VIPA. The manual consists of chapters. Every chapter provides the description of one specific topic.
It describes the installation, project engineering, usage and the technical data.

This manual is relevant for:

Product	Order number	ab Stand:	
		HW	FW
CC 03	VIPA 603-xCC21	01	406
	VIPA 603-xCC22	02	412
	VIPA 603-xCC23	02	412

Guide to the document

This manual provides the following guides:

- An overall table of contents at the beginning of the manual
- An overview of the topics for every chapter

Availability

The manual is available in:

- printed form, on paper
- in electronic form as PDF-file (Adobe Acrobat Reader)

Description conventions

[Button] Buttons are put in brackets e.g. [NEXT] or [OK].
 [Key] Key entry are put in brackets e.g. [STRG]+[A].
 Display output Display outputs are illustrated as Courier e.g. \flashdisk>
Keyboard entry Keyboard entries are illustrated as **Courier bold** e.g. \flashdisk> **Dir**
Terms Menus, Display elements, terms are *italics*.

Icons Headings

Important passages in the text are highlighted by following icons and headings:



Danger!
 Immediate or likely danger.
 Personal injury is possible.



Attention!
 Damages to property is likely if these warnings are not heeded.



Note!
 Supplementary information and useful tips.

Safety information

Applications conforming with specifications

The Commander Compact is constructed and manufactured for:

- VIPA CPUs 11x, 21x, 31x, 51x and S7-300/400 from Siemens
- communication and process control
- general control and automation applications
- industrial applications
- operation within the environmental conditions specified in the technical data
- installation into a cubicle



Danger!

This device is not certified for applications in

- in explosive environments (EX-zone)

Documentation

The manual must be available to all personnel in the

- project design department
- installation department
- commissioning
- operation



The following conditions must be met before using or commissioning the components described in this manual:

- Modification to the process control system should only be carried out when the system has been disconnected from power!
- Installation and modifications only by properly trained personnel
- The national rules and regulations of the respective country must be satisfied (installation, safety, EMC ...)

Disposal

National rules and regulations apply to the disposal of the unit!

Chapter 1 Hardware description

Overview

In this chapter the hardware components of the CC 03 are described. Besides of a description of the single components, the dimensions that are required for the installation of the CC 03 may also be found. The chapter closes with the technical data.

Please consider the safety hints at the beginning of the chapter.

Content

Topic	Page
Chapter 1 Hardware description	1-1
Safety information for Users	1-2
Properties	1-4
Structure	1-5
Components	1-6
Dimensions	1-11
CC-CPU - Function security	1-12
Technical data	1-13

Safety information for Users

Handling of electrostatic sensitive modules

VIPA modules make use of highly integrated components in MOS-technology. These components are extremely sensitive to over-voltages that can occur during electrostatic discharges.

The following symbol is attached to modules that can be destroyed by electrostatic discharges:



The symbol is located on the module, the module rack or on packing material and it indicates the presence of electrostatic sensitive equipment.

It is possible that electrostatic sensitive equipment is destroyed by energies and voltages that are far less than the human threshold of perception. These voltages can occur where persons do not discharge themselves before handling electrostatic sensitive modules and they can damage components thereby, causing the module to become inoperable or unusable.

Modules that have been damaged by electrostatic discharges may fail after a temperature change, mechanical shock or changes in the electrical load.

Only the consequent implementation of protection devices and meticulous attention to the applicable rules and regulations for handling the respective equipment can prevent failures of electrostatic sensitive modules.



Attention!

- Before commissioning, the device has to be brought in environment temperature.
- With condensation you may only switch on the device after complete dryness.
- To prevent overheat during operation avoid direct sun contact of the device.
- After opening of the control cabinet or panel, parts of the system are available that may lead dangerous voltage.
- All signal connections require screened cables.
- Signal cores may not be lead within a cable shaft of high-voltage cores.
- Please take care for sufficient ground of the operating device. For this a ground screw is to be found at the backside of the device.

Shipping of electrostatic sensitive modules

Modules have to be shipped in the original packing material.

Measurements and alterations on electrostatic sensitive modules

When you are conducting measurements on electrostatic sensitive modules you should take the following precautions:

- Floating instruments must be discharged before use.
- Instruments must be grounded.

Modifying electrostatic sensitive modules you should only use soldering irons with grounded tips.

**Attention!**

Personnel and instruments should be grounded when working on electrostatic sensitive modules.

Properties

General

With the CC 03 there is access to the internal CPU. The CC 03 allows you to monitor and influence operating states and recent process values from internal CPU. The CC 03 may optionally be connected to the PLC system as PROFIBUS-DP slave (VIPA 603-2CC2x).

For the comfortable entry of values and navigation, the CC 03 is provided with an integrated keyboard and a 2x20 character display. In addition there is a PLC-CPU which is programmable by STEP[®]7 from Siemens and an I/O periphery integrated to the CC 03.

From the software side the connection happens by means of a CC 03 project. The project may be created by means of the VIPA OP-Manager or by ProTool from Siemens. The project may be transferred from the PC to the CC 03 by MPI or MMC. During operation, the CC 03 communicates with the internal CPU and responds to the application processing of the CPU according to the engineered presetting.



CC 03 603-xCC2x

- Die-cast aluminum case, installation via non-looseable rocker arms
- Protection type: front side IP65, back side IP20
- Display with 2 x 20 characters
- 128kB user memory, 4096 variables
- MP²I interface for project engineering, CPU link-up and firmware update
- Project engineering via VIPA OP-Manager or Siemens ProTool
- Menus and input requests in 8 languages
- Read and alter time and counter value, Monitoring of messages
- Integrated PLC-CPU with Real-time clock und status-LEDs on the panel
- MMC slot for external MMC storage medium
- Integrated I/O periphery, expansion option via extension cable

Order data

Type	Order number	Description
CC 03	VIPA 603-2CC2x	with integrated PROFIBUS-DP slave
	VIPA 603-xCC21	with 16kB work memory/ 24kB load memory
	VIPA 603-xCC22	with 24kB work memory/ 32kB load memory
	VIPA 603-xCC23	with 24kB work memory/ 32kB load memory
MPI cable	VIPA 670-0KB00	OP/AG cable 0°/90° with PU-/Diagnostic port, 2.5m

Structure

Front view

At the front side of the Commander Compact CC 03 are the foil keyboard, the display with 2x20 characters and the Status LEDs of the CPU.

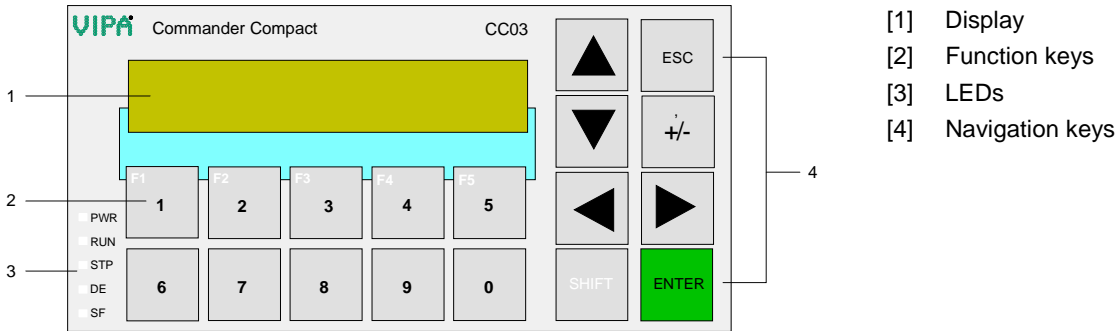

- [1] Display
- [2] Function keys
- [3] LEDs
- [4] Navigation keys

Back view

At the CC 03 the connectors are located at back side.

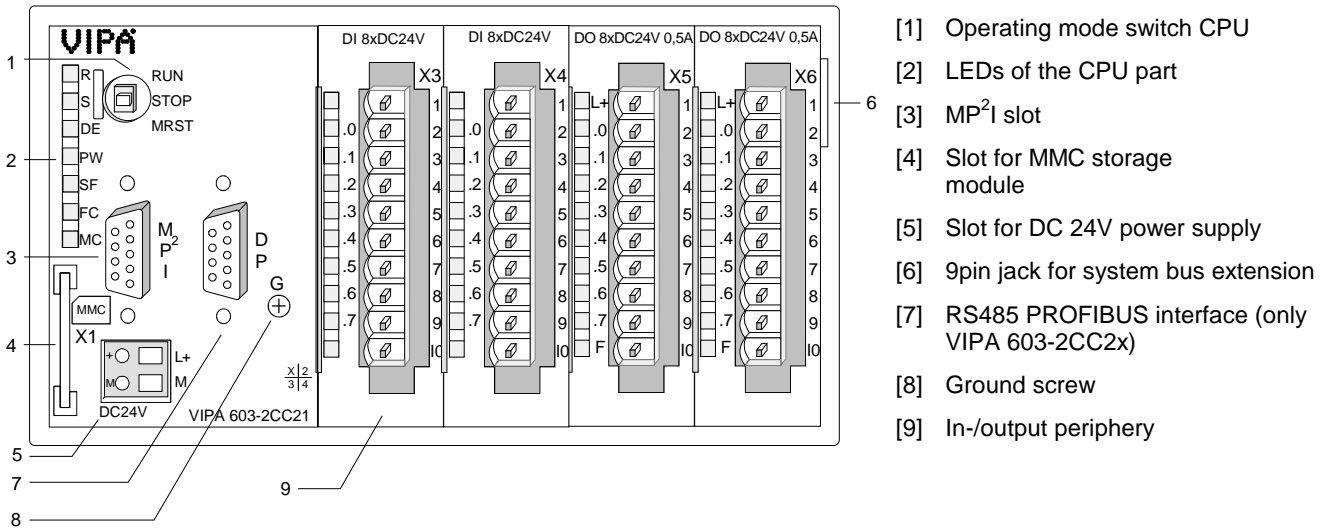

- [1] Operating mode switch CPU
- [2] LEDs of the CPU part
- [3] MP²I slot
- [4] Slot for MMC storage module
- [5] Slot for DC 24V power supply
- [6] 9pin jack for system bus extension
- [7] RS485 PROFIBUS interface (only VIPA 603-2CC2x)
- [8] Ground screw
- [9] In-/output periphery

Components

LC-Display

The CC 03 monitors values and messages via a STN text display with LED back lighting. It displays 2 rows with max. 20 characters with a line height of 5mm.

Keyboard

At the front side is a foil keyboard with 18 short click keys. 8 keys are serving the navigation and 10 keys are for numeric input.

The numeric keys F1 ... F5 are configurable as soft key with display depending functions via the VIPA project engineering tool.

MP²I

The CC 03 is provided with a MP²I (**M**ulti-**P**oint-**I**nterface) for connection to your CPU via a MPI network and for connection to the PC for project engineering and firmware update.

The MPI jack has the following pin assignment:

9pin jack

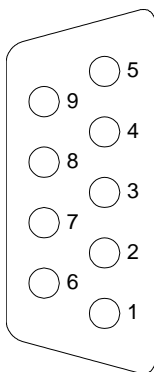

Pin	Assignment
1	reserved (must not be connected)
2	M24V
3	RxD/TxD-P (Line B)
4	RTS
5	M5V
6	P5V
7	P24V
8	RxD/TxD-N (Line A)
9	n.c.

PROFIBUS- DP slave interface (only 603-2CC2x)

Via a 9pin RS485 interface, the CC 03DP is linked-up to PROFIBUS as DP slave. For project engineering in a PROFIBUS DP master the VIPA GSD file vipa04dx.gsd is necessary.

The following picture illustrates the pin assignment of the interface:

9pin jack

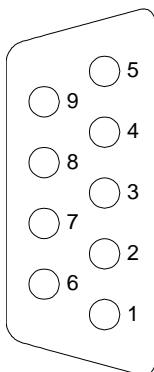

Pin	Assignment
1	Screen
2	n.c.
3	RxD/TxD-P (Line B)
4	RTS
5	M5V
6	P5V
7	n.c.
8	RxD/TxD-N (Line A)
9	n.c.

Extension jack

Every CC 03 has an integrated 9pin jack at the side. This jack allows you to extend the CC 03 with up to 4 System 100V expansion modules res. System 200V modules. Please regard that the maximum current load of 800mA for the backplane bus must not be exceeded.

To connect your modules, a special bus coupling cable is required that is available with order number VIPA 660-0KB00 at VIPA. For the connection, the bus cable is provided with a 9pin plug at one side and a 1tier bus coupler at the other. The project engineering of the expansion periphery happens in the hardware configurator from Siemens.

Power supply

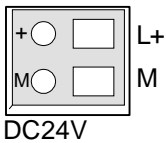

The CC 03 has an integrated power supply. The power supply has to be provided with DC 24V (20.4 ... 28.8V). For this an according DC 24V slot is located at the back side. The power supply is protected against inverse polarity and overcurrent.

Besides of the electronics, the supply voltage feeds also the optional components like output periphery, DP slave and bus extension.



Note!

Please regard that the bus extension may stand a max. of 800mA.

LEDs

The LEDs at the backside serve the status monitoring of the integrated CPU and the optional PROFIBUS-DP slave. All LEDs except of FC and MC are also at the front side. The following table shows color and usage:

Label	Color	Description
R	Green	CPU is in the operating mode RUN
S	Yellow	CPU is in the operating mode STOP
DE	Yellow	DE (D ata E xchange) indicates PROFIBUS communication activity of the DP slave. (only VIPA 603-2CC2x).
PW	Green	CPU portion is supplied internal
SF	Red	On at system error (hardware failure)
FC	Yellow	On as soon as variables are forced*
MC	Yellow	Shows access to MMC *

* only back side

**Operating mode switch
RUN/STOP/MRST**

With the operating mode switch you may choose between the operating modes STOP and RUN. The operating mode START-UP is processed automatically by the CPU between STOP and RUN.

By means of the switch location Memory Reset (MRST) you request an overall reset res. a firmware update from a plugged MMC.

MMC slot storage module

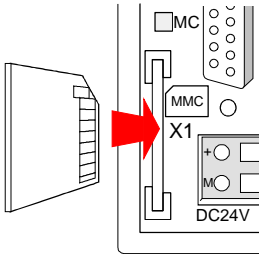

As external storage medium you may plug in a MMC storage module from VIPA (Order-No.: VIPA 953-0KX10). Access to the MMC always takes place after an overall reset and after PowerON.

Also available at VIPA is an external MMC reading device (Order-No: VIPA 950-0AD00). This allows you to write onto res. read your MMC at the PC.

Please take care at insertion of the MMC that the flatted part is upside like shown in the picture.



Note!

Please regard that a write command is followed by an error message when no MMC is plugged.

Although the data is stored in the internal Flash-ROM.

Battery buffer for clock and RAM

Every CC-CPU has an internal accu for protecting the RAM at black-out. Additionally the internal real-time clock is buffered via the accu.

The accu is loaded directly via the integrated power supply by means of special loading electronics and guarantees a buffer for max. 30 days.



Attention!

That the CC-CPU is able to switch to RUN, the accu has to be in good condition.

If there is a defect at the accu, the CC-CPU switches to STOP and announces a sum error. In this case you should check the CC-CPU. Please contact VIPA for that purpose!

Internal Flash-ROM

Additional to the battery buffered RAM, the CC-CPU has got an internal Flash-ROM with the size of the corresponding load memory.

Via the writing command **PLC** > *Copy RAM to ROM* from the destination system functions of the hardware configurator from Siemens, the contents of the load memory are transferred into the Flash-ROM and simultaneously to the MMC, if plugged in.

The CC-CPU only accesses the contents of the Flash-ROM if the battery buffered RAM is empty.

The Flash-ROM is not deleted by an overall reset. The Flash-ROM may be cleared by means of requesting an overall reset and then transferring the now empty load memory into the Flash-ROM via the PLC function *Copy RAM to ROM*.

I/O periphery
DI 16xDC24V
DO 16xDC24V

The CC 03 has an integrated I/O periphery which assignment is described in the following. Please regard that the output section has to be provided with external DC 24V!

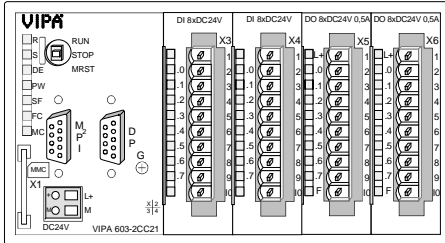

Position 1	Position 2	Position 3	Position 4
X3	X4	X5	X6
DI 8xDC 24V	DI 8xDC 24V	DO 8xDC 24V 0.5A	DO 8xDC 24V 0.5A

Status monitor
pin assignment

LED Description Digital Input Pin Assignment

.0... .7 LEDs (green)
I+0.0 to I+0.7
from ca. 15V on the signal "1" is recognized and the according LED is addressed

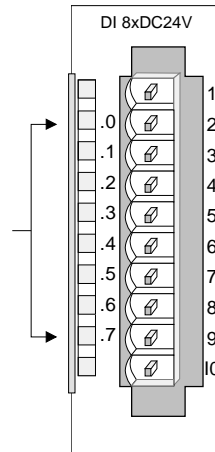

1 not used
2 Input I+0.0
3 Input I+0.1
4 Input I+0.2
5 Input I+0.3
6 Input I+0.4
7 Input I+0.5
8 Input I+0.6
9 Input I+0.7
10 Ground

LED Description Digital Output Pin Assignment

L+ LED (green)
Supply voltage is available
.0... .7 LEDs (green)
Q+0.0 to Q+0.7
as soon as an output is active, the according LED is addressed
F LED (red)
Error at overload, overheat or short circuits

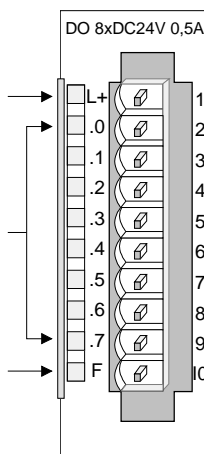

1 Supply voltage DC 24V
2 Output Q+0.0
3 Output Q+0.1
4 Output Q+0.2
5 Output Q+0.3
6 Output Q+0.4
7 Output Q+0.5
8 Output Q+0.6
9 Output Q+0.7
10 Supply voltage ground

Circuit diagram

Connect the in-/outputs like shown in the picture:

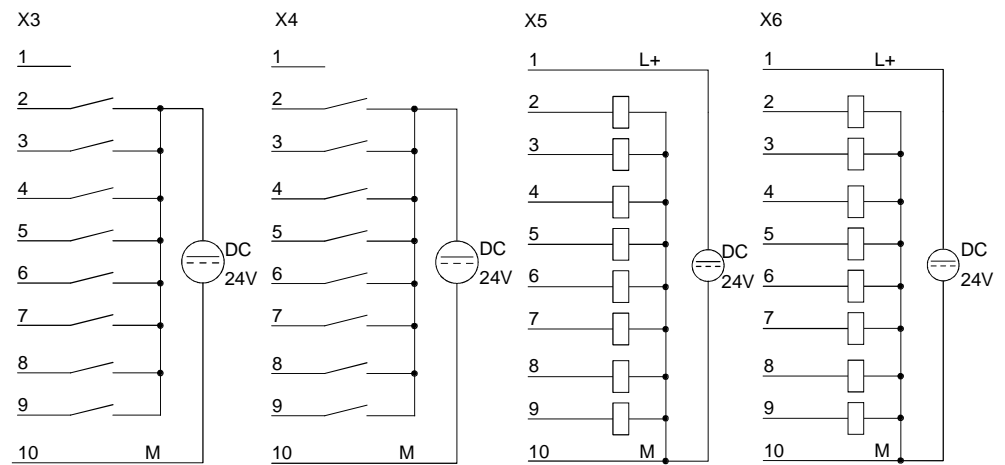

Schematic diagram

Input part

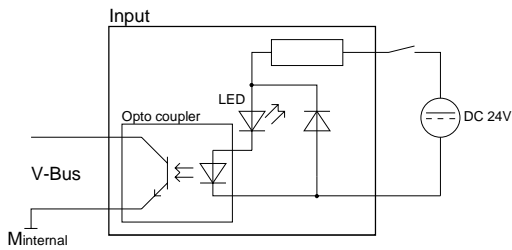

Output part

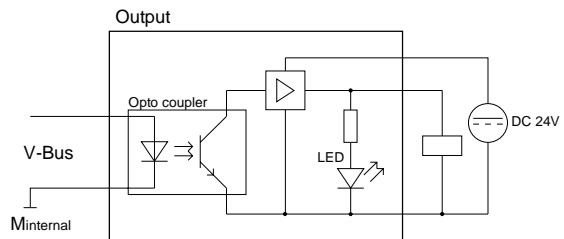

Dimensions

Installation dimensions

For the installation of the CC 03, an installation cutting with the dimensions 156 x 78mm is required.

Installation values for control cabinets and desks:

Front panel width:	2.5 ... 6mm
Installation cutting (W x H):	156 x 78mm
Installation depth plus cabling	55mm

Top view

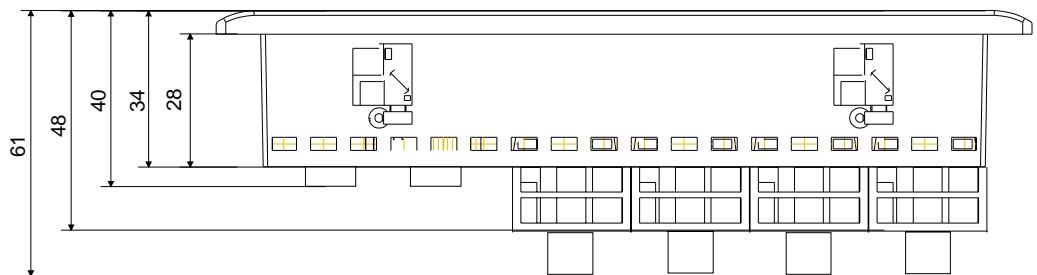

Back view

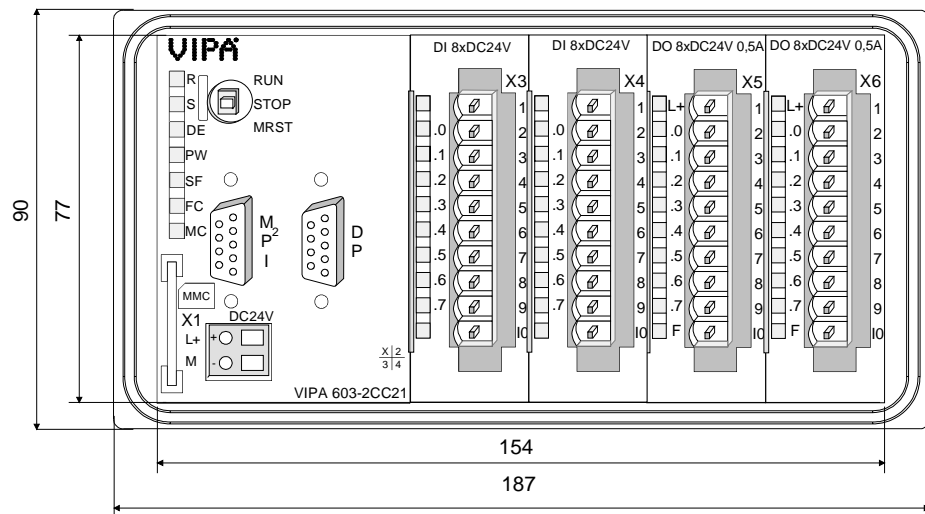

CC-CPU - Function security

Overview The CPU of the CC 03 includes security mechanisms like a watchdog (100ms) and a parameterizable cycle time surveillance (parameterizable min. 1ms) that stop res. execute a RESET at the CPU in case of an error and set it into a defined STOP state.

System properties The VIPA CPUs are developed function secure and have the following system properties:

Event	concerns	Effect
RUN → STOP	general central digital outputs central analog outputs decentral outputs decentral inputs	BASP (B efehls- A usgabe- S perre, i.e. command output lock) is set. The outputs are set to 0V. The voltage supply for the output channels is switched off. The outputs are set to 0V. The inputs are read constantly from the slave and the recent values are put at disposal.
STOP → RUN res. Power on	general central analog outputs decentral inputs	First the PII is deleted, the call of the OB100 follows. After the execution of the OB, the BASP is set back and the cycle starts with: Delete PIQ → Read PII → OB1. The behavior of the outputs at restart can be preset. The inputs are read constantly from the slave and the recent values are put at disposal.
RUN	general	The program execution happens cyclically and can therefore be foreseen: Read PII → OB1 → Write PIQ.

PII: = Process image inputs

PIQ: = Process image outputs

Technical data

Order number	603-1CC21
Type	CC 03, Commander Compact
Display	
Number of rows	2
Characters per row	20
Character height	5 mm
Type of display	STN with LED backlighting
OP functionality	
User memory	128 KB
Number of variables	4096
Language	DE/EN/FR/ES/IT/SV/NO/DA
Operating controls	
Touchscreen	-
Mouse	-
Number of system keys	8
Number of soft keys	5
Technical data power supply	
Power supply (rated value)	DC 24 V
Power supply (permitted range)	DC 20.4...28.8 V
Current consumption (rated value)	400 mA
Inrush current	3 A
Status information, alarms, diagnostics	
Status display	yes
Interrupts	no
Process alarm	yes
Diagnostic interrupt	yes
Diagnostic functions	no
Diagnostics information read-out	possible
Supply voltage display	green LED
Group error display	red SF LED
Channel error display	red LED per group
Technical data digital inputs	
Number of inputs	16
Cable length, shielded	1000 m
Cable length, unshielded	600 m
Rated load voltage	DC 24 V
Reverse polarity protection of rated load voltage	✓
Rated value	DC 24 V
Input voltage for signal "0"	DC 0...5 V
Input voltage for signal "1"	DC 15...28.8 V
Input current for signal "1"	7 mA
Connection of Two-Wire-BEROs possible	✓
Max. permissible BERO quiescent current	1.5 mA
Input delay of "0" to "1"	3 ms
Input delay of "1" to "0"	3 ms
Input characteristic curve	IEC 61131, type 1
Initial data size	2 Byte
Technical data digital outputs	
Number of outputs	16
Cable length, shielded	1000 m
Cable length, unshielded	600 m
Rated load voltage	DC 24 V
Reverse polarity protection of rated load voltage	-
Current consumption from load voltage L+ (without load)	50 mA
Output voltage signal "1" at min. current	L+ (-0.8 V)
Output voltage signal "1" at max. current	-
Output current at signal "1", rated value	0.5 A
Output delay of "0" to "1"	max. 100 µs
Output delay of "1" to "0"	max. 350 µs
Minimum load current	-

Order number	603-1CC21
Lamp load	5 W
Switching frequency with resistive load	max. 1000 Hz
Switching frequency with inductive load	max. 0.5 Hz
Switching frequency on lamp load	max. 10 Hz
Internal limitation of inductive shut-off voltage	L+ (-52 V)
Short-circuit protection of output	yes, electronic
Trigger level	1 A
Output data size	2 Byte
Isolation	
Insulation tested with	DC 500 V
Load and working memory	
Load memory, integrated	24 KB
Work memory, integrated	16 KB
Memory card slot	MMC-Card with max. 512 MB
Command processing times	
Bit instructions, min.	0.25 µs
Word instruction, min.	1.2 µs
Double integer arithmetic, min.	-
Floating-point arithmetic, min.	-
Timers/Counters and their retentive characteristics	
Number of S7 counters	256
Number of S7 times	256
Data range and retentive characteristic	
Number of flags	8192 Bit
Number of data blocks	2047
Max. data blocks size	16 KB
Max. local data size per execution level	1024 Byte
Blocks	
Number of OBs	14
Number of FBs	1024
Number of FCs	1024
Maximum nesting depth per priority class	8
Maximum nesting depth additional within an error OB	4
Time	
Real-time clock buffered	✓
Clock buffered period (min.)	30 d
Number of operating hours counter	8
Synchronization in the PLC	no
Synchronization via MPI	no
Synchronization via DP master	no
Synchronization via DP slave	no
Synchronization via Ethernet (NTP)	no
Address areas (I/O)	
Input I/O address area	1024 Bit
Output I/O address area	1024 Bit
Digital inputs	128
Digital outputs	128
Integrated digital inputs	16
Integrated digital outputs	16
Communication functions	
PG/OP channel	✓
Global data communication	✓
Number of GD circuits, max.	4
Size of GD packets, max.	22 Byte
S7 basic communication	✓
S7 basic communication, user data per job	76 Byte
S7 communication	✓
S7 communication as server	✓
S7 communication as client	-
S7 communication, user data per job	160 Byte
Number of connections, max.	16
Functionality Sub-D interfaces	
Type	MP2I

Order number	603-1CC21
Type of interface	RS485
Connector	Sub-D, 9-pin, female
Electrically isolated	-
MPI	✓
MP ² I (MPI/RS232)	✓
DP master	-
DP slave	-
Point-to-point interface	-
Functionality	
Type	-
Type of interface	-
Connector	-
Electrically isolated	-
MPI	-
MP ² I (MPI/RS232)	-
DP master	-
DP slave	-
Point-to-point interface	-
CAN	-
Functionality PROFIBUS slave	
PG/OP channel	-
Routing	-
S7 communication	-
S7 communication as server	-
S7 communication as client	-
Direct data exchange (slave-to-slave communication)	-
DPV1	-
Transmission speed, min.	-
Transmission speed, max.	-
Automatic detection of transmission speed	-
Transfer memory inputs, max.	-
Transfer memory outputs, max.	-
Address areas, max.	-
User data per address area, max.	-
Mechanical data	
Housing / Protection type	
Material	die-cast aluminum
Mounting	via integrated pivoted lever
Protect type front side	IP 65
Protect type back side	IP 20
Dimensions	
Front panel	187 x 90 x 6 mm
Rear panel	154 x 77 x 55 mm
Installation cut-out	
Width	156 mm
Height	78 mm
Minimum front panel thickness	2.5 mm
Maximum front panel thickness	6 mm
Weight	580 g
Environmental conditions	
Operating temperature	0 °C to 60 °C
Storage temperature	-20 °C to 70 °C
Certifications	
UL508 certification	yes

Order number	603-1CC22
Type	CC 03, Commander Compact
Display	
Number of rows	2
Characters per row	20
Character height	5 mm
Type of display	STN with LED backlighting
OP functionality	
User memory	128 KB
Number of variables	4096
Language	DE/EN/FR/ES/IT/SV/NO/DA
Operating controls	
Touchscreen	-
Mouse	-
Number of system keys	8
Number of soft keys	5
Technical data power supply	
Power supply (rated value)	DC 24 V
Power supply (permitted range)	DC 20.4...28.8 V
Current consumption (rated value)	400 mA
Inrush current	3 A
Status information, alarms, diagnostics	
Status display	yes
Interrupts	no
Process alarm	yes
Diagnostic interrupt	yes
Diagnostic functions	no
Diagnostics information read-out	possible
Supply voltage display	green LED
Group error display	red SF LED
Channel error display	red LED per group
Technical data digital inputs	
Number of inputs	16
Cable length, shielded	1000 m
Cable length, unshielded	600 m
Rated load voltage	DC 24 V
Reverse polarity protection of rated load voltage	✓
Rated value	DC 24 V
Input voltage for signal "0"	DC 0...5 V
Input voltage for signal "1"	DC 15...28.8 V
Input current for signal "1"	7 mA
Connection of Two-Wire-BEROs possible	✓
Max. permissible BERO quiescent current	1.5 mA
Input delay of "0" to "1"	3 ms
Input delay of "1" to "0"	3 ms
Input characteristic curve	IEC 61131, type 1
Initial data size	2 Byte
Technical data digital outputs	
Number of outputs	16
Cable length, shielded	1000 m
Cable length, unshielded	600 m
Rated load voltage	DC 24 V
Reverse polarity protection of rated load voltage	-
Current consumption from load voltage L+ (without load)	50 mA
Output voltage signal "1" at min. current	L+ (-0.8 V)
Output voltage signal "1" at max. current	-
Output current at signal "1", rated value	0.5 A
Output delay of "0" to "1"	max. 100 µs
Output delay of "1" to "0"	max. 350 µs
Minimum load current	-
Lamp load	5 W
Switching frequency with resistive load	max. 1000 Hz
Switching frequency with inductive load	max. 0.5 Hz
Switching frequency on lamp load	max. 10 Hz

Order number	603-1CC22
Internal limitation of inductive shut-off voltage	L+ (-52 V)
Short-circuit protection of output	yes, electronic
Trigger level	1 A
Output data size	2 Byte
Isolation	
Insulation tested with	DC 500 V
Load and working memory	
Load memory, integrated	32 KB
Work memory, integrated	24 KB
Memory card slot	MMC-Card with max. 512 MB
Command processing times	
Bit instructions, min.	0.25 µs
Word instruction, min.	1.2 µs
Double integer arithmetic, min.	-
Floating-point arithmetic, min.	-
Timers/Counters and their retentive characteristics	
Number of S7 counters	256
Number of S7 times	256
Data range and retentive characteristic	
Number of flags	8192 Bit
Number of data blocks	2047
Max. data blocks size	16 KB
Max. local data size per execution level	1024 Byte
Blocks	
Number of OBs	14
Number of FBs	1024
Number of FCs	1024
Maximum nesting depth per priority class	8
Maximum nesting depth additional within an error OB	4
Time	
Real-time clock buffered	✓
Clock buffered period (min.)	30 d
Number of operating hours counter	8
Synchronization in the PLC	no
Synchronization via MPI	no
Synchronization via DP master	no
Synchronization via DP slave	no
Synchronization via Ethernet (NTP)	no
Address areas (I/O)	
Input I/O address area	1024 Bit
Output I/O address area	1024 Bit
Digital inputs	128
Digital outputs	128
Integrated digital inputs	16
Integrated digital outputs	16
Communication functions	
PG/OP channel	✓
Global data communication	✓
Number of GD circuits, max.	4
Size of GD packets, max.	22 Byte
S7 basic communication	✓
S7 basic communication, user data per job	76 Byte
S7 communication	✓
S7 communication as server	✓
S7 communication as client	-
S7 communication, user data per job	160 Byte
Number of connections, max.	16
Functionality Sub-D interfaces	
Type	MP2I
Type of interface	RS485
Connector	Sub-D, 9-pin, female
Electrically isolated	-
MPI	✓

Order number	603-1CC22
MP2I (MPI/RS232)	✓
DP master	-
DP slave	-
Point-to-point interface	-
Functionality	
Type	-
Type of interface	-
Connector	-
Electrically isolated	-
MPI	-
MP2I (MPI/RS232)	-
DP master	-
DP slave	-
Point-to-point interface	-
CAN	-
Functionality PROFIBUS slave	
PG/OP channel	-
Routing	-
S7 communication	-
S7 communication as server	-
S7 communication as client	-
Direct data exchange (slave-to-slave communication)	-
DPV1	-
Transmission speed, min.	-
Transmission speed, max.	-
Automatic detection of transmission speed	-
Transfer memory inputs, max.	-
Transfer memory outputs, max.	-
Address areas, max.	-
User data per address area, max.	-
Mechanical data	
Housing / Protection type	
Material	die-cast aluminum
Mounting	via integrated pivoted lever
Protect type front side	IP 65
Protect type back side	IP 20
Dimensions	
Front panel	187 x 90 x 6 mm
Rear panel	154 x 77 x 55 mm
Installation cut-out	
Width	156 mm
Height	78 mm
Minimum front panel thickness	2.5 mm
Maximum front panel thickness	6 mm
Weight	580 g
Environmental conditions	
Operating temperature	0 °C to 60 °C
Storage temperature	-20 °C to 70 °C
Certifications	
UL508 certification	in preparation

Order number	603-1CC23
Type	CC 03, Commander Compact
Display	
Number of rows	2
Characters per row	20
Character height	5 mm
Type of display	STN with LED backlighting
OP functionality	
User memory	128 KB
Number of variables	4096
Language	DE/EN/FR/ES/IT/SV/NO/DA
Operating controls	
Touchscreen	-
Mouse	-
Number of system keys	8
Number of soft keys	5
Technical data power supply	
Power supply (rated value)	DC 24 V
Power supply (permitted range)	DC 20.4...28.8 V
Current consumption (rated value)	400 mA
Inrush current	3 A
Status information, alarms, diagnostics	
Status display	yes
Interrupts	no
Process alarm	yes
Diagnostic interrupt	yes
Diagnostic functions	no
Diagnostics information read-out	possible
Supply voltage display	green LED
Group error display	red SF LED
Channel error display	red LED per group
Technical data digital inputs	
Number of inputs	16
Cable length, shielded	1000 m
Cable length, unshielded	600 m
Rated load voltage	DC 24 V
Reverse polarity protection of rated load voltage	✓
Rated value	DC 24 V
Input voltage for signal "0"	DC 0...5 V
Input voltage for signal "1"	DC 15...28.8 V
Input current for signal "1"	7 mA
Connection of Two-Wire-BEROs possible	✓
Max. permissible BERO quiescent current	1.5 mA
Input delay of "0" to "1"	3 ms
Input delay of "1" to "0"	3 ms
Input characteristic curve	IEC 61131, type 1
Initial data size	2 Byte
Technical data digital outputs	
Number of outputs	16
Cable length, shielded	1000 m
Cable length, unshielded	600 m
Rated load voltage	DC 24 V
Reverse polarity protection of rated load voltage	-
Current consumption from load voltage L+ (without load)	50 mA
Output voltage signal "1" at min. current	L+ (-0.8 V)
Output voltage signal "1" at max. current	-
Output current at signal "1", rated value	0.5 A
Output delay of "0" to "1"	max. 100 µs
Output delay of "1" to "0"	max. 350 µs
Minimum load current	-
Lamp load	5 W
Switching frequency with resistive load	max. 1000 Hz
Switching frequency with inductive load	max. 0.5 Hz
Switching frequency on lamp load	max. 10 Hz

Order number	603-1CC23
Internal limitation of inductive shut-off voltage	L+ (-52 V)
Short-circuit protection of output	yes, electronic
Trigger level	1 A
Output data size	2 Byte
Isolation	
Insulation tested with	DC 500 V
Load and working memory	
Load memory, integrated	40 KB
Work memory, integrated	32 KB
Memory card slot	MMC-Card with max. 512 MB
Command processing times	
Bit instructions, min.	0.25 µs
Word instruction, min.	1.2 µs
Double integer arithmetic, min.	-
Floating-point arithmetic, min.	-
Timers/Counters and their retentive characteristics	
Number of S7 counters	256
Number of S7 times	256
Data range and retentive characteristic	
Number of flags	8192 Bit
Number of data blocks	2047
Max. data blocks size	16 KB
Max. local data size per execution level	1024 Byte
Blocks	
Number of OBs	14
Number of FBs	1024
Number of FCs	1024
Maximum nesting depth per priority class	8
Maximum nesting depth additional within an error OB	4
Time	
Real-time clock buffered	✓
Clock buffered period (min.)	30 d
Number of operating hours counter	8
Synchronization in the PLC	no
Synchronization via MPI	no
Synchronization via DP master	no
Synchronization via DP slave	no
Synchronization via Ethernet (NTP)	no
Address areas (I/O)	
Input I/O address area	1024 Bit
Output I/O address area	1024 Bit
Digital inputs	128
Digital outputs	128
Integrated digital inputs	16
Integrated digital outputs	16
Communication functions	
PG/OP channel	✓
Global data communication	✓
Number of GD circuits, max.	4
Size of GD packets, max.	22 Byte
S7 basic communication	✓
S7 basic communication, user data per job	76 Byte
S7 communication	✓
S7 communication as server	✓
S7 communication as client	-
S7 communication, user data per job	160 Byte
Number of connections, max.	16
Functionality Sub-D interfaces	
Type	MP2I
Type of interface	RS485
Connector	Sub-D, 9-pin, female
Electrically isolated	-
MPI	✓

Order number	603-1CC23
MP2I (MPI/RS232)	✓
DP master	-
DP slave	-
Point-to-point interface	-
Functionality	
Type	-
Type of interface	-
Connector	-
Electrically isolated	-
MPI	-
MP2I (MPI/RS232)	-
DP master	-
DP slave	-
Point-to-point interface	-
CAN	-
Functionality PROFIBUS slave	
PG/OP channel	-
Routing	-
S7 communication	-
S7 communication as server	-
S7 communication as client	-
Direct data exchange (slave-to-slave communication)	-
DPV1	-
Transmission speed, min.	-
Transmission speed, max.	-
Automatic detection of transmission speed	-
Transfer memory inputs, max.	-
Transfer memory outputs, max.	-
Address areas, max.	-
User data per address area, max.	-
Mechanical data	
Housing / Protection type	
Material	die-cast aluminum
Mounting	via integrated pivoted lever
Protect type front side	IP 65
Protect type back side	IP 20
Dimensions	
Front panel	187 x 90 x 6 mm
Rear panel	154 x 77 x 55 mm
Installation cut-out	
Width	156 mm
Height	78 mm
Minimum front panel thickness	2.5 mm
Maximum front panel thickness	6 mm
Weight	580 g
Environmental conditions	
Operating temperature	0 °C to 60 °C
Storage temperature	-20 °C to 70 °C
Certifications	
UL508 certification	in preparation

Order number	603-2CC21
Type	CC 03DP, Commander Compact, PROFIBUS-DP slave
Display	
Number of rows	2
Characters per row	20
Character height	5 mm
Type of display	STN with LED backlighting
OP functionality	
User memory	128 KB
Number of variables	4096
Language	DE/EN/FR/ES/IT/SV/NO/DA
Operating controls	
Touchscreen	-
Mouse	-
Number of system keys	8
Number of soft keys	5
Technical data power supply	
Power supply (rated value)	DC 24 V
Power supply (permitted range)	DC 20.4...28.8 V
Current consumption (rated value)	400 mA
Inrush current	3 A
Status information, alarms, diagnostics	
Status display	yes
Interrupts	no
Process alarm	yes
Diagnostic interrupt	yes
Diagnostic functions	no
Diagnostics information read-out	possible
Supply voltage display	green LED
Group error display	red SF LED
Channel error display	red LED per group
Technical data digital inputs	
Number of inputs	16
Cable length, shielded	1000 m
Cable length, unshielded	600 m
Rated load voltage	DC 24 V
Reverse polarity protection of rated load voltage	✓
Rated value	DC 24 V
Input voltage for signal "0"	DC 0...5 V
Input voltage for signal "1"	DC 15...28.8 V
Input current for signal "1"	7 mA
Connection of Two-Wire-BEROs possible	✓
Max. permissible BERO quiescent current	1.5 mA
Input delay of "0" to "1"	3 ms
Input delay of "1" to "0"	3 ms
Input characteristic curve	IEC 61131, type 1
Initial data size	2 Byte
Technical data digital outputs	
Number of outputs	16
Cable length, shielded	1000 m
Cable length, unshielded	600 m
Rated load voltage	DC 24 V
Reverse polarity protection of rated load voltage	-
Current consumption from load voltage L+ (without load)	50 mA
Output voltage signal "1" at min. current	L+ (-0.8 V)
Output voltage signal "1" at max. current	-
Output current at signal "1", rated value	0.5 A
Output delay of "0" to "1"	max. 100 µs
Output delay of "1" to "0"	max. 350 µs
Minimum load current	-
Lamp load	5 W
Switching frequency with resistive load	max. 1000 Hz
Switching frequency with inductive load	max. 0.5 Hz

Order number	603-2CC21
Switching frequency on lamp load	max. 10 Hz
Internal limitation of inductive shut-off voltage	L+ (-52 V)
Short-circuit protection of output	yes, electronic
Trigger level	1 A
Output data size	2 Byte
Isolation	
Insulation tested with	DC 500 V
Load and working memory	
Load memory, integrated	24 KB
Work memory, integrated	16 KB
Memory card slot	MMC-Card with max. 512 MB
Command processing times	
Bit instructions, min.	0.25 µs
Word instruction, min.	1.2 µs
Double integer arithmetic, min.	-
Floating-point arithmetic, min.	-
Timers/Counters and their retentive characteristics	
Number of S7 counters	256
Number of S7 times	256
Data range and retentive characteristic	
Number of flags	8192 Bit
Number of data blocks	2047
Max. data blocks size	16 KB
Max. local data size per execution level	1024 Byte
Blocks	
Number of OBs	14
Number of FBs	1024
Number of FCs	1024
Maximum nesting depth per priority class	8
Maximum nesting depth additional within an error OB	4
Time	
Real-time clock buffered	✓
Clock buffered period (min.)	30 d
Number of operating hours counter	8
Synchronization in the PLC	no
Synchronization via MPI	no
Synchronization via DP master	no
Synchronization via DP slave	no
Synchronization via Ethernet (NTP)	no
Address areas (I/O)	
Input I/O address area	1024 Bit
Output I/O address area	1024 Bit
Digital inputs	128
Digital outputs	128
Integrated digital inputs	16
Integrated digital outputs	16
Communication functions	
PG/OP channel	✓
Global data communication	✓
Number of GD circuits, max.	4
Size of GD packets, max.	22 Byte
S7 basic communication	✓
S7 basic communication, user data per job	76 Byte
S7 communication	✓
S7 communication as server	✓
S7 communication as client	-
S7 communication, user data per job	160 Byte
Number of connections, max.	16
Functionality Sub-D interfaces	
Type	MP2I
Type of interface	RS485
Connector	Sub-D, 9-pin, female
Electrically isolated	-

Order number	603-2CC21
MPI	✓
MP ² I (MPI/RS232)	✓
DP master	-
DP slave	-
Point-to-point interface	-
DP	
Type	DP
Type of interface	RS485
Connector	Sub-D, 9-pin, female
Electrically isolated	✓
MPI	-
MP ² I (MPI/RS232)	-
DP master	-
DP slave	✓
Point-to-point interface	-
CAN	-
Functionality PROFIBUS slave	
PG/OP channel	-
Routing	-
S7 communication	-
S7 communication as server	-
S7 communication as client	-
Direct data exchange (slave-to-slave communication)	-
DPV1	-
Transmission speed, min.	9.6 kbit/s
Transmission speed, max.	12 Mbit/s
Automatic detection of transmission speed	✓
Transfer memory inputs, max.	64 Byte
Transfer memory outputs, max.	64 Byte
Address areas, max.	-
User data per address area, max.	-
Mechanical data	
Housing / Protection type	
Material	die-cast aluminum
Mounting	via integrated pivoted lever
Protect type front side	IP 65
Protect type back side	IP 20
Dimensions	
Front panel	187 x 90 x 6 mm
Rear panel	154 x 77 x 55 mm
Installation cut-out	
Width	156 mm
Height	78 mm
Minimum front panel thickness	2.5 mm
Maximum front panel thickness	6 mm
Weight	600 g
Environmental conditions	
Operating temperature	0 °C to 60 °C
Storage temperature	-20 °C to 70 °C
Certifications	
UL508 certification	yes

Order number	603-2CC22
Type	CC 03DP, Commander Compact, PROFIBUS-DP slave
Display	
Number of rows	2
Characters per row	20
Character height	5 mm
Type of display	STN with LED backlighting
OP functionality	
User memory	128 KB
Number of variables	4096
Language	DE/EN/FR/ES/IT/SV/NO/DA
Operating controls	
Touchscreen	-
Mouse	-
Number of system keys	8
Number of soft keys	5
Technical data power supply	
Power supply (rated value)	DC 24 V
Power supply (permitted range)	DC 20.4...28.8 V
Current consumption (rated value)	400 mA
Inrush current	3 A
Status information, alarms, diagnostics	
Status display	yes
Interrupts	no
Process alarm	yes
Diagnostic interrupt	yes
Diagnostic functions	no
Diagnostics information read-out	possible
Supply voltage display	green LED
Group error display	red SF LED
Channel error display	red LED per group
Technical data digital inputs	
Number of inputs	16
Cable length, shielded	1000 m
Cable length, unshielded	600 m
Rated load voltage	DC 24 V
Reverse polarity protection of rated load voltage	✓
Rated value	DC 24 V
Input voltage for signal "0"	DC 0...5 V
Input voltage for signal "1"	DC 15...28.8 V
Input current for signal "1"	7 mA
Connection of Two-Wire-BEROs possible	✓
Max. permissible BERO quiescent current	1.5 mA
Input delay of "0" to "1"	3 ms
Input delay of "1" to "0"	3 ms
Input characteristic curve	IEC 61131, type 1
Initial data size	2 Byte
Technical data digital outputs	
Number of outputs	16
Cable length, shielded	1000 m
Cable length, unshielded	600 m
Rated load voltage	DC 24 V
Reverse polarity protection of rated load voltage	-
Current consumption from load voltage L+ (without load)	50 mA
Output voltage signal "1" at min. current	L+ (-0.8 V)
Output voltage signal "1" at max. current	-
Output current at signal "1", rated value	0.5 A
Output delay of "0" to "1"	max. 100 µs
Output delay of "1" to "0"	max. 350 µs
Minimum load current	-
Lamp load	5 W
Switching frequency with resistive load	max. 1000 Hz
Switching frequency with inductive load	max. 0.5 Hz

Order number	603-2CC22
Switching frequency on lamp load	max. 10 Hz
Internal limitation of inductive shut-off voltage	L+ (-52 V)
Short-circuit protection of output	yes, electronic
Trigger level	1 A
Output data size	2 Byte
Isolation	
Insulation tested with	DC 500 V
Load and working memory	
Load memory, integrated	32 KB
Work memory, integrated	24 KB
Memory card slot	MMC-Card with max. 512 MB
Command processing times	
Bit instructions, min.	0.25 µs
Word instruction, min.	1.2 µs
Double integer arithmetic, min.	-
Floating-point arithmetic, min.	-
Timers/Counters and their retentive characteristics	
Number of S7 counters	256
Number of S7 times	256
Data range and retentive characteristic	
Number of flags	8192 Bit
Number of data blocks	2047
Max. data blocks size	16 KB
Max. local data size per execution level	1024 Byte
Blocks	
Number of OBs	14
Number of FBs	1024
Number of FCs	1024
Maximum nesting depth per priority class	8
Maximum nesting depth additional within an error OB	4
Time	
Real-time clock buffered	✓
Clock buffered period (min.)	30 d
Number of operating hours counter	8
Synchronization in the PLC	no
Synchronization via MPI	no
Synchronization via DP master	no
Synchronization via DP slave	no
Synchronization via Ethernet (NTP)	no
Address areas (I/O)	
Input I/O address area	1024 Bit
Output I/O address area	1024 Bit
Digital inputs	128
Digital outputs	128
Integrated digital inputs	16
Integrated digital outputs	16
Communication functions	
PG/OP channel	✓
Global data communication	✓
Number of GD circuits, max.	4
Size of GD packets, max.	22 Byte
S7 basic communication	✓
S7 basic communication, user data per job	76 Byte
S7 communication	✓
S7 communication as server	✓
S7 communication as client	-
S7 communication, user data per job	160 Byte
Number of connections, max.	16
Functionality Sub-D interfaces	
Type	MP2I
Type of interface	RS485
Connector	Sub-D, 9-pin, female
Electrically isolated	-

Order number	603-2CC22
MPI	✓
MP2I (MPI/RS232)	✓
DP master	-
DP slave	-
Point-to-point interface	-
DP Slave	
Type	DP
Type of interface	RS485
Connector	Sub-D, 9-pin, female
Electrically isolated	✓
MPI	-
MP2I (MPI/RS232)	-
DP master	-
DP slave	✓
Point-to-point interface	-
CAN	-
Functionality PROFIBUS slave	
PG/OP channel	-
Routing	-
S7 communication	-
S7 communication as server	-
S7 communication as client	-
Direct data exchange (slave-to-slave communication)	-
DPV1	-
Transmission speed, min.	9.6 kbit/s
Transmission speed, max.	12 Mbit/s
Automatic detection of transmission speed	✓
Transfer memory inputs, max.	64 Byte
Transfer memory outputs, max.	64 Byte
Address areas, max.	-
User data per address area, max.	-
Mechanical data	
Housing / Protection type	
Material	die-cast aluminum
Mounting	via integrated pivoted lever
Protect type front side	IP 65
Protect type back side	IP 20
Dimensions	
Front panel	187 x 90 x 6 mm
Rear panel	154 x 77 x 55 mm
Installation cut-out	
Width	156 mm
Height	78 mm
Minimum front panel thickness	2.5 mm
Maximum front panel thickness	6 mm
Weight	600 g
Environmental conditions	
Operating temperature	0 °C to 60 °C
Storage temperature	-20 °C to 70 °C
Certifications	
UL508 certification	in preparation

Order number	603-2CC23
Type	CC 03DP, Commander Compact, PROFIBUS-DP slave
Display	
Number of rows	2
Characters per row	20
Character height	5 mm
Type of display	STN with LED backlighting
OP functionality	
User memory	128 KB
Number of variables	4096
Language	DE/EN/FR/ES/IT/SV/NO/DA
Operating controls	
Touchscreen	-
Mouse	-
Number of system keys	8
Number of soft keys	5
Technical data power supply	
Power supply (rated value)	DC 24 V
Power supply (permitted range)	DC 20.4...28.8 V
Current consumption (rated value)	400 mA
Inrush current	3 A
Status information, alarms, diagnostics	
Status display	yes
Interrupts	no
Process alarm	yes
Diagnostic interrupt	yes
Diagnostic functions	no
Diagnostics information read-out	possible
Supply voltage display	green LED
Group error display	red SF LED
Channel error display	red LED per group
Technical data digital inputs	
Number of inputs	16
Cable length, shielded	1000 m
Cable length, unshielded	600 m
Rated load voltage	DC 24 V
Reverse polarity protection of rated load voltage	✓
Rated value	DC 24 V
Input voltage for signal "0"	DC 0...5 V
Input voltage for signal "1"	DC 15...28.8 V
Input current for signal "1"	7 mA
Connection of Two-Wire-BEROs possible	✓
Max. permissible BERO quiescent current	1.5 mA
Input delay of "0" to "1"	3 ms
Input delay of "1" to "0"	3 ms
Input characteristic curve	IEC 61131, type 1
Initial data size	2 Byte
Technical data digital outputs	
Number of outputs	16
Cable length, shielded	1000 m
Cable length, unshielded	600 m
Rated load voltage	DC 24 V
Reverse polarity protection of rated load voltage	-
Current consumption from load voltage L+ (without load)	50 mA
Output voltage signal "1" at min. current	L+ (-0.8 V)
Output voltage signal "1" at max. current	-
Output current at signal "1", rated value	0.5 A
Output delay of "0" to "1"	max. 100 µs
Output delay of "1" to "0"	max. 350 µs
Minimum load current	-
Lamp load	5 W
Switching frequency with resistive load	max. 1000 Hz
Switching frequency with inductive load	max. 0.5 Hz

Order number	603-2CC23
Switching frequency on lamp load	max. 10 Hz
Internal limitation of inductive shut-off voltage	L+ (-52 V)
Short-circuit protection of output	yes, electronic
Trigger level	1 A
Output data size	2 Byte
Isolation	
Insulation tested with	DC 500 V
Load and working memory	
Load memory, integrated	40 KB
Work memory, integrated	32 KB
Memory card slot	MMC-Card with max. 512 MB
Command processing times	
Bit instructions, min.	0.25 µs
Word instruction, min.	1.2 µs
Double integer arithmetic, min.	-
Floating-point arithmetic, min.	-
Timers/Counters and their retentive characteristics	
Number of S7 counters	256
Number of S7 times	256
Data range and retentive characteristic	
Number of flags	8192 Bit
Number of data blocks	2047
Max. data blocks size	16 KB
Max. local data size per execution level	1024 Byte
Blocks	
Number of OBs	14
Number of FBs	1024
Number of FCs	1024
Maximum nesting depth per priority class	8
Maximum nesting depth additional within an error OB	4
Time	
Real-time clock buffered	✓
Clock buffered period (min.)	30 d
Number of operating hours counter	8
Synchronization in the PLC	no
Synchronization via MPI	no
Synchronization via DP master	no
Synchronization via DP slave	no
Synchronization via Ethernet (NTP)	no
Address areas (I/O)	
Input I/O address area	1024 Bit
Output I/O address area	1024 Bit
Digital inputs	128
Digital outputs	128
Integrated digital inputs	16
Integrated digital outputs	16
Communication functions	
PG/OP channel	✓
Global data communication	✓
Number of GD circuits, max.	4
Size of GD packets, max.	22 Byte
S7 basic communication	✓
S7 basic communication, user data per job	76 Byte
S7 communication	✓
S7 communication as server	✓
S7 communication as client	-
S7 communication, user data per job	160 Byte
Number of connections, max.	16
Functionality Sub-D interfaces	
Type	MP2I
Type of interface	RS485
Connector	Sub-D, 9-pin, female
Electrically isolated	-

Order number	603-2CC23
MPI	✓
MP2I (MPI/RS232)	✓
DP master	-
DP slave	-
Point-to-point interface	-
DP Slave	
Type	DP
Type of interface	RS485
Connector	Sub-D, 9-pin, female
Electrically isolated	✓
MPI	-
MP2I (MPI/RS232)	-
DP master	-
DP slave	✓
Point-to-point interface	-
CAN	-
Functionality PROFIBUS slave	
PG/OP channel	-
Routing	-
S7 communication	-
S7 communication as server	-
S7 communication as client	-
Direct data exchange (slave-to-slave communication)	-
DPV1	-
Transmission speed, min.	9.6 kbit/s
Transmission speed, max.	12 Mbit/s
Automatic detection of transmission speed	✓
Transfer memory inputs, max.	64 Byte
Transfer memory outputs, max.	64 Byte
Address areas, max.	-
User data per address area, max.	-
Mechanical data	
Housing / Protection type	
Material	die-cast aluminum
Mounting	via integrated pivoted lever
Protect type front side	IP 65
Protect type back side	IP 20
Dimensions	
Front panel	187 x 90 x 6 mm
Rear panel	154 x 77 x 55 mm
Installation cut-out	
Width	156 mm
Height	78 mm
Minimum front panel thickness	2.5 mm
Maximum front panel thickness	6 mm
Weight	600 g
Environmental conditions	
Operating temperature	0 °C to 60 °C
Storage temperature	-20 °C to 70 °C
Certifications	
UL508 certification	in preparation

Chapter 2 Deployment CC 03 - Operator panel

Overview

This chapter explains the deployment and the project engineering of the operator panel of the CC 03.

After the fast introduction there are information about the installation of the CC 03 and the configuration by the OP-Manager. This is followed by notes for commissioning. The chapter closes with a description of the operation of the panel.

Content

Topic	Page
Chapter 2 Deployment CC 03 - Operator panel	2-1
Fast introduction.....	2-2
Installation	2-6
Cabling.....	2-7
Project engineering operator panel	2-8
Commissioning.....	2-16
Deployment operator panel	2-19

Fast introduction

Installation

For the installation in operating tables and control cabinet fronts a front panel cutting of 156mmx78mm (LxW) is needed.

Configuration

The project engineering for access to the internal CPU takes place in the configuration tool "OP-Manager" from VIPA that enables the online project engineering via MPI.

Deployment OP-Manager





Start the OP-Manager via click on `opmnggr.exe`.

Open the dialog window for a new project via **File** > *New*. Enter a name and the according operating device and click on `Next >`. For the first start, you should work with the standard project. Click on `Use standard project`. The project window opens with the standard project that is already stored in the operator panel.

Now you may change the values of the object groups "Screens", "Messages", "Tags" etc. by clicking on the according group and preset their objects in the object window.

Create, alter and delete an object

Within an object group you may create a new object via , alter it via  and delete it with . These functions are equal to the context functions *Insert*, *Open res. Properties* and *Delete*.

Controllers

This entry is automatically generated and is essential for communication between CC 03 and its CPU. **Don't make any changes, please!**

Create tag

With Tags you define all variables that refer to memory areas of the PLC and that have to be processed in the OP.



To create a new variable, click on . Enter a name for the variable and a corresponding memory area of the internal CPU.

Messages



The display of a message happens event triggered. As soon as an event occurs in the specified CPU, the according message is monitored sorted after priority that can be acknowledged with . The definition of the events happens under "Area Pointer" on project level. Here you assign a memory res. bit memory area of your PLC. The object groups "Messages" allow you to enter the according messages.

Create screen

Click on the object group "Screens" and create a new screen with . Screens consist of entries. Every screen can contain up to 20 entries. Always one entry is monitored per display page in a 2x20 character mask where you can branch if needed. You may enter the following elements in an entry:

- Alpha numeric texts (no umlaut)
- Variables for in- res. output via  as:
 - Tag: Variable that is linked to a value in the PLC with settable in- res. output format. You may also output plain text from a list that concerns to a PLC value. The list for the text assignment is stored in the object group "Text/Graphics Lists".
 - Date, Time: internal date and time-of-day
- Soft key  that allows to execute programmed functions like e.g. a jump in a special entry.

Compile and emulate

After you have finished the presetting, you save your project with , compile it with  and start it with an emulator with . The emulator creates an OP 03 on your PC and gives you the opportunity to test your programming without additional hardware. The usage of OP 03 is as the same as the usage of the CC 03.

 brings you to the screen defined as start screen. The lower part of the emulator allows you to simulate events via PLC 1 that are later coming from the internal CPU. Please take care that the according events are programmed in your project engineering under "Area Pointers".

You may also use the menu option "Switch to Green Cable Mode" to directly connect your PC with the CPU of the CC 03 via Green Cable and test your programming on the emulator.

**Note!**

The online project engineering requires a licensed version of the OP-Manager! More information may be found at the online help of the OP-Manager.

Commissioning

For commissioning and project engineering the CC 03 is to be externally power supplied by DC 24V and connected to the PC. For connection there are the following possibilities:

- Transfer online
- Transfer by MMC



Note!

The CC 03 is always to be externally power supplied by DC 24V.

Transfer online by Green Cable

Here the transfer is executed via an exclusively directly connected Green Cable from VIPA and external power supply.

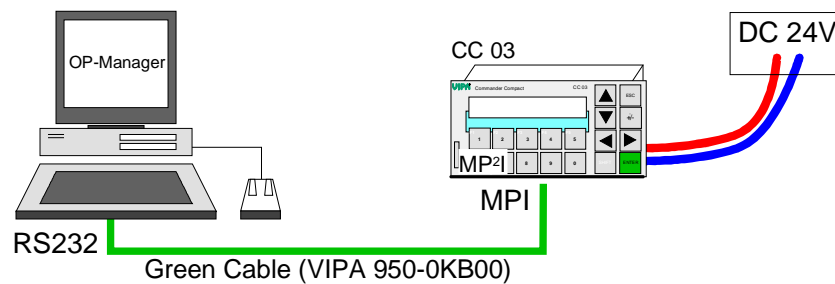

Attention!

- The Green Cable may exclusively deployed directly at the concerning jacks of the VIPA components (in between plugs are not permitted).
- The lengthening of the Green Cable with another Green Cable res. The combination with further MPI cables is not permitted and causes damages of the connected components! The Green Cable may only be lengthened with a 1:1 cable (all 9 Pins are connected 1:1).

Transfer online by MPI adapter

With this transfer method the connection happens by means of a MPI adapter cable. The MPI converter cables are available from VIPA in different versions. At the PC side the MPI converter cable may be connected to the RS232 interface or the USB slot depending on the version.

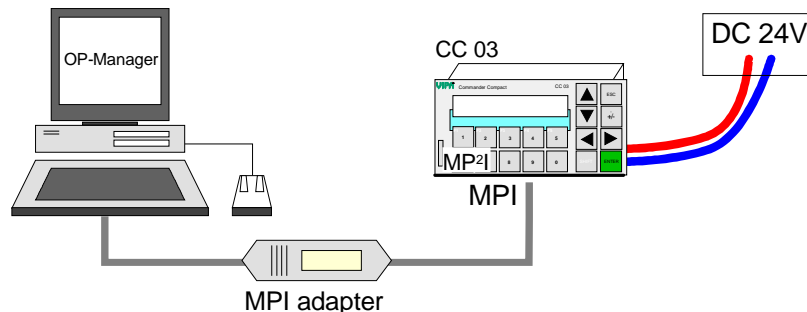

Prepare CC 03 for data transfer

If the standard project is in the CC 03, you may set the OP mode "Operat. mode Transfer" via **System** > **OP-Mode** > **SHIFT** + **▼**, entering the password 100 and confirm with **ENTER**. Now the CC 03 awaits data with "Ready for Transfer".

Start transfer at OP-Manager

Load the OP-Manager with your project on your PC. You may only access the CC 03 online, if you work with a licensed version.





Call the transfer function with a click on .

Select MPI and set the transfer parameters like COM port, baud rate 38400 via  and confirm your entry.

With  configuration is confirmed and the transfer is started.

Transfer by MMC

With a licensed version of the OP-Manager there is the possibility to store your project as a MMC file. The file may be transferred to a MMC and read from MMC by the CC 03.

- Load your project in the OP-Manager on your PC and compile the project.
- Only a licensed version allows you to save your project as cfg-file using **File > Save Blocks as > MMC-File**.
- Copy this file to your MMC and rename it to vp3.cfg.
- Insert the MMC into the MMC slot of the CC 03.
- Push the key combination  +  + , switch on the CC 03 and keep pushing the keys until the CC 03 branches to the "Setup-Menu".
- Choose "Perform Load Prog from MMC" by using  and push . The CC 03 announces "Storing configuration" and shows a reboot with "Restarting".
At wrong file name, the message "No program file found" occurs. With no plugged MMC, you receive the message "No MMC found".
- Now the MMC may be removed

Operation

After project transfer the CC 03 starts with the new project.

As soon as the power supply of the CC 03 is switched on it starts automatically with the project.

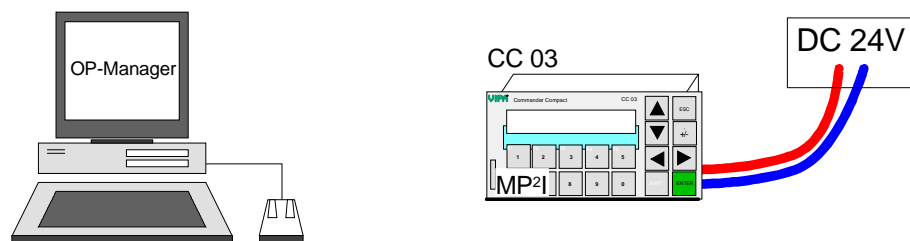

These steps of the fast introduction are more described at the following pages.

Installation

Overview

The CC 03 is suitable for the installation in operating tables and control cabinet fronts. The installation happens via the back side. The CC 03 is provided with a patented integrated fixing technique that allows an easy connection with a simple screwdriver.



Note!

Please also regard the "General installation guidelines" in this manual.

Installation cutting

For the installation in operating tables and control cabinet fronts, you need the following front panel cutting:

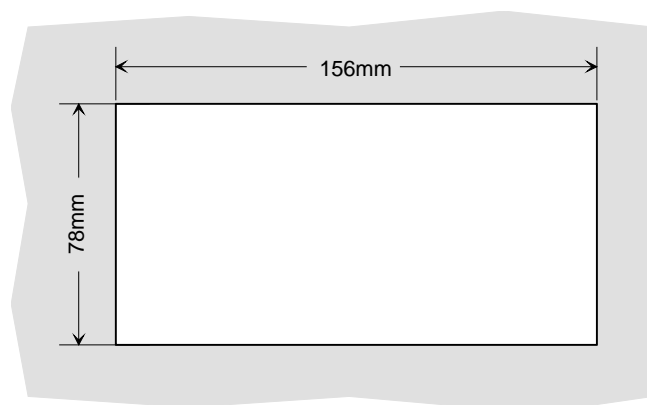

Installation

The fixing technique is integrated in the casing of the CC 03 and accessible via the back side.

For the installation, a small slit screwdriver is required. Push the operator panel [3] from the front side into the front panel cutting [1] until it touches the panel with the seal [2]. Now bolt the lever [5] clockwise with the screwdriver [4] until it rotates to the outside. Further screwing bolts the lever to the front panel until it holds the CC 03 to the control cabinet front.

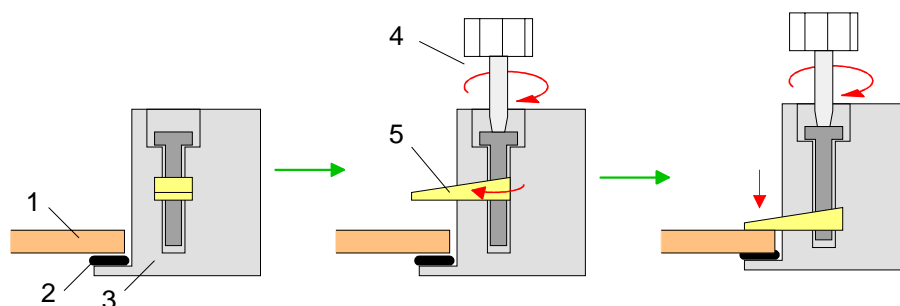

Cabling

Connecting external power supply

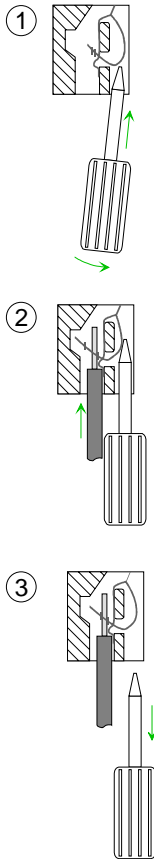

For external DC 24V power supply there is a connector at the back side of the CC 03.

The wiring takes place with spring clamp technology. The cabling with spring clamp technique enables a fast and easy connection of your supply wires. In opposite to a screw connection, this connection is vibration secure. You may connect cables with a cross-section of 0.08 mm² to 2.5 mm². You may use flexible cores without end case as well as stiff wires.

The wires are fixed at the spring clamp contacts as follows:

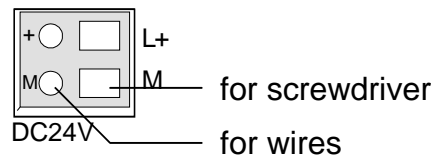

The illustration on the left side shows the steps of the cabling seen from top.

- To conduct a wire you plug a fitting screwdriver obliquely into the rectangular opening like shown in the picture.
- To open the contact spring you have to push the screwdriver in the opposite direction and hold it.
- Insert the de-isolated wire into the round opening. You may use wires with a cross-section from 0.08mm² to 2.5mm².
- By removing the screwdriver the wire is connected safely with the plug connector via a spring.

Connecting I/O periphery

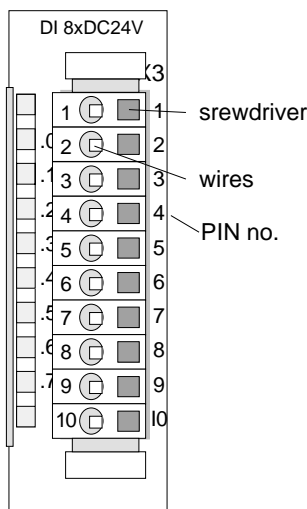

The in-/output periphery has one 10pin plug connector per module (1 column). This plug connects the signal and supply lines of the in res. outputs. For the wiring connection plugs with spring clamp technique are also used.

The pin assignment of the I/O periphery is to be found in the description of the modules.

You may connect cores with a diameter of 0.08mm² to 2.5mm² (up to 1.5mm² with 18pin).

The following illustration shows a module with a 10pin plug.

The spring clip will be destroyed when inserting a screw driver into the core opening!

Insert the screw driver exclusively into the rectangle openings of the plug!

Project engineering operator panel

Overview

For the project engineering of the CC 03 operator panel surface you may use the OP-Manager from VIPA or ProTool from Siemens.

For both tools are similar in structure and operation, the project engineering is illustrated in the OP-Manager from VIPA.

The OP-Manager runs with Windows 2000 and XP. The OP-Manager offers you a fully graphical user interface that allows you a comfortable project engineering in 3 different languages.

You transfer your project engineering into your operator device via MPI.

Differences to ProTool

In opposite to ProTool, the OP-Manager has an integrated emulator that simulates an operation panel on your PC. You can test your project engineering without additional hardware. You may also use the COM interface to connect a CPU via MPI that can be accessed by the emulator.

The area pointers are to find in the OP-Manager in the register "Area Pointer".

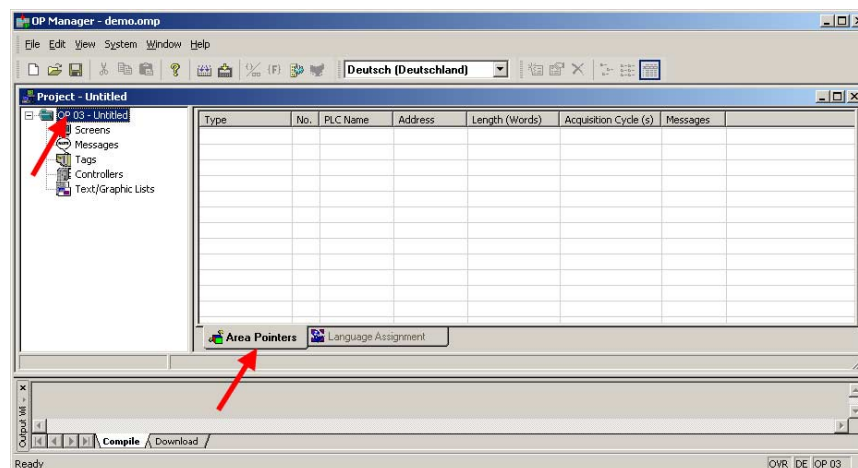

The languages that are available in your project are set in the register "Language Assignment".

Glossary

The following table lists the terms that are used for the project engineering in the OP-Manager.

<i>Meaning</i>	<i>Term</i>	<i>Meaning</i>	<i>Term</i>
Pictures	Screens	PLC	Controllers
Messages	Messages	Symbolic lists	Text/Graphic Lists
Variables	Tags	Area Pointer	Area Pointer

Create project



Start the OP-Manager by clicking on `opmnggr.exe`.

Open the dialog window for a new project via **File** > *New*. Enter a name and the according operating device and click on `Next >`. For the first start, you should work with the standard project. Click on `Use standard project`. The project window opens with the standard project that is already stored in the CC.

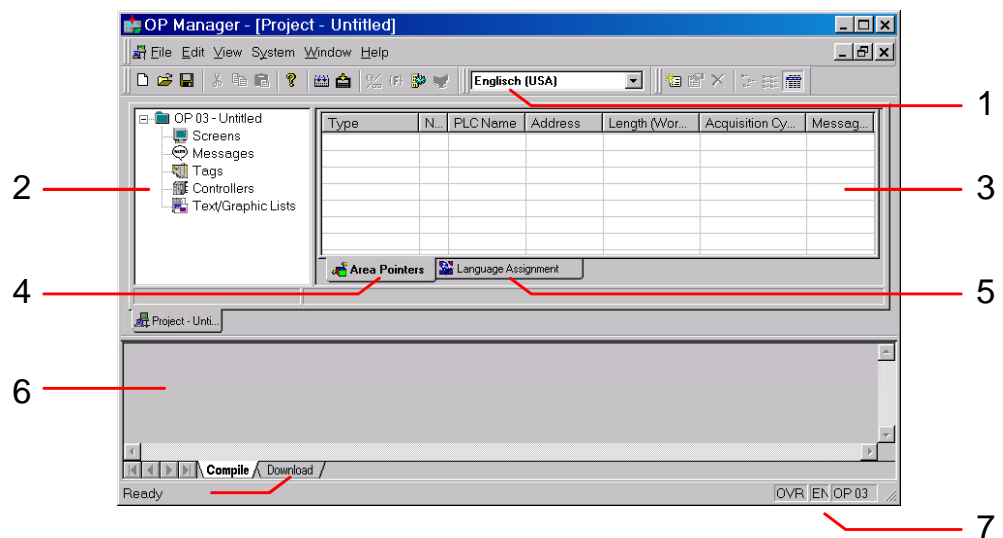

You may alter the name for your project or add a description via **File** > *Project Information* at any time.



The project window contains the following important elements:

- [1] Symbol bar with the most important functions. Here you also set the language that is to be altered.
- [2] This area shows your project with the concerning object groups in a tree structure.
- [3] Here you see the objects of an object group.
- [4] As soon as you choose your project as object group, among others, the register "Area Pointer" is available. Under "Area Pointer" you may assign certain events in your CPU to a state in your CC like e.g. open a screen or throw one of the messages that you can define under "Messages".
- [5] As soon as you choose your project as object group, among others, the register "Language Assignment" is available. Here up to 3 languages may be set which languages are available in your project.
- [6] Here are the status messages that are creates at a compiler run res. Download.
- [7] OP-Manager information window. Information about the entry mode (OVR=Overwrite), the chosen language and the type of the operating panel.

Insert objects

Within an object group you may create a new project via  in the symbol bar, alter it with  and delete it with . These functions are equal to the context functions *Insert*, *Open res. Properties* and *Delete*.

Object overview

The following objects are available:

- Controllers (CPU and MPI communication parameter)
- Tags (Variables referring to PLC areas)
- Messages (messages that can be thrown event triggered)
- Screens (output areas on the operator panel)
- Text/Graphic Lists (Plain text assignment for tags)

Controllers (CPUs)

When you create a new project, a controller is automatically created too. At deployment of the CC 03 here must be exactly 1 controller entry because you only have access to the integrated CPU. **Please do not change these settings!**

Tags (Variables)

Under "Tags" you define all variables that refer to memory areas of your PLC and have to be processed by the CC.

Click on  to create a new variable. Enter a name for the new tag and a corresponding memory area of your CPU.

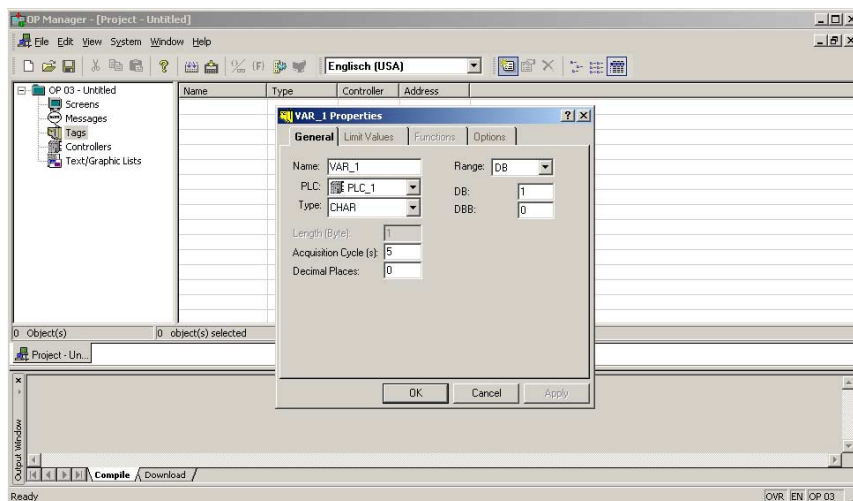



Via the register "Limit Value" you may define areas for input variables. When you enter a value exceeding this range, the input is rejected. Some variable types can be configured via the register "Functions". "Options" allows you to enter a comment to the variables.

Messages

The output of a message happens event triggered. As soon as an event occurs in the specified CPU, the according messages are shown sorted by priority.

Please regard that you first have to define the initializing event in the project object group, register "Area Pointer", if you want a message because of a CPU event.

For this, create a new object with the type "Event Messages" via the register "Area Pointer" with  and assign a DB or bit memory area. For the output follows the bit pattern of the defined area, several messages can be displayed simultaneously. The output is sorted after priority starting with priority 1. Every message must be acknowledged with .



Screens

"Screens" allows you to monitor an image of the process. You may display processes and preset process values.

The screen object contains several screen entries. One screen entry has display size (2x20 characters) and is marked with an entry number. With the object name and the entry number you may directly access a screen entry.

You may place the following elements into a screen object:

- Alpha numeric texts
- Variables for in- res. output via  as:
 - Tag: Variable that is linked to a value in the PLC with settable in- res. output format. You may also output plain text from a list that concerns to a PLC value. The list for the text assignment is stored in the object group "Text/Graphics Lists".
 - Date: internal date
 - Time: internal time-of-day

The format of date respectively time of day and the flashing of the input fields may be set by .
- Soft key   that allows to execute programmed functions like e.g. a jump in a special entry.

Screens (Continue)

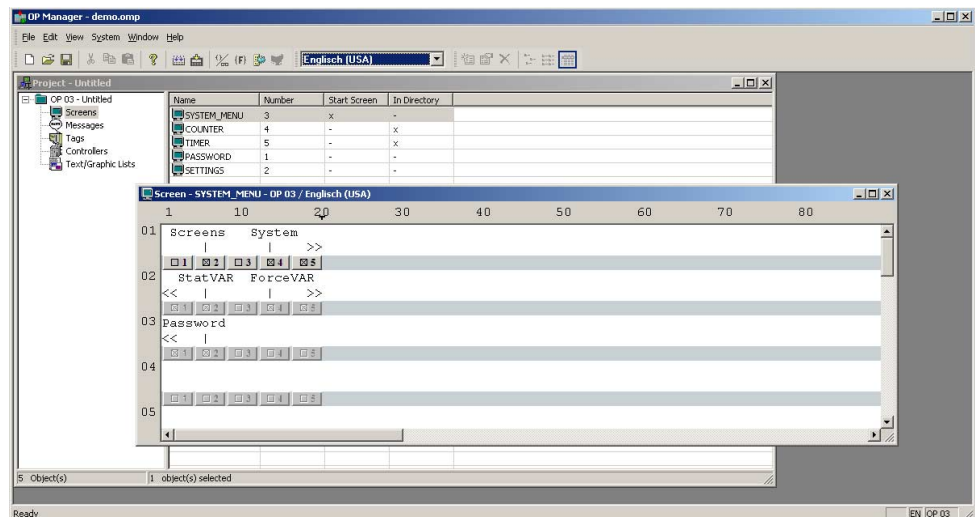

Click on the object group Screens and create a new screen with . Click on the 1. screen entry and insert the wanted elements. This screen is automatically the start screen. You can assign the "start screen" property to another screen via the object properties.

You may also alter the language during the project engineering. This only influences the monitored text.

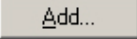

Function keys (Soft keys)

Every screen entry has a soft key bar in the lower part of the window. Here you can assign a function to one of the function keys (1...5). Click on the according function key and assign a function via  like e.g. jump into screen entry.

The access to the soft keys may be configured with or without additional  key. This may be set with .

Password protection for soft keys

To prevent unauthorized operating, the CC 03 has an integrated password protection that enables passwords for up to 8 levels. Access to all password levels (Level 9) is only allowed with the "Supervisor-Password" that is defined in your project.

The assignment of the according password level happens in the OP-Manager. Here you can assign password levels from 1 to 9 according to the raising importance of the functions assigned to the soft keys. Setting Level 0 deactivates the password request.

You may set the passwords for the levels 1 to 8 only at the CC 03. You need access to the screen "Password" in your project (see standard project).

For access to this screen, the "Supervisor-Password" is required.

Set Supervisor-Password

The Supervisor-Password allows full access to all functions of the CC 03. The Supervisor-Password is transferred to the CC 03 together with the project. To enter the Supervisor-Password, choose  in your project. The following dialog window appears:

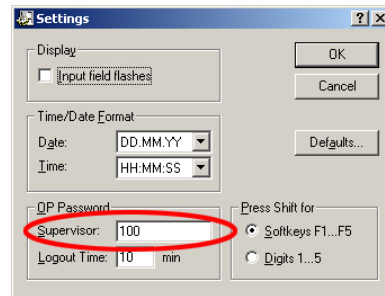

Under "Supervisor" you type a password and set via "Logout Time" the time for which the password is valid after login.

Set password level

You may set a password level for every soft key definition like shown in the picture.

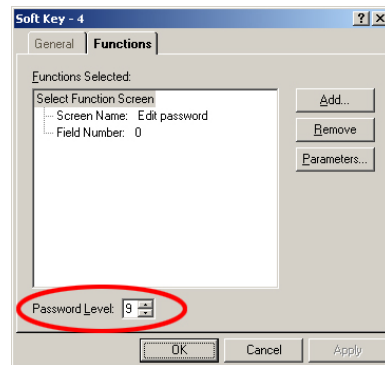

Please regard that the password levels for integrated standard screens of the CC 03 are preset e.g.:

Level 9: Password Edit, OP-Mode

Level 8: ForceVAR

Level 6: System>MPI-Addr

Level 4: System>Dat/Time

Level 2: System>Language

Level 0: StatVAR, Password>Logout

Text/Graphics Lists This object allows you to assign a text to a numeric value, which you can refer to via a tag (variable).

Mark the object group "Text/Graphics Lists" and add a new object with  **Add...** assigns a text to a numeric value.

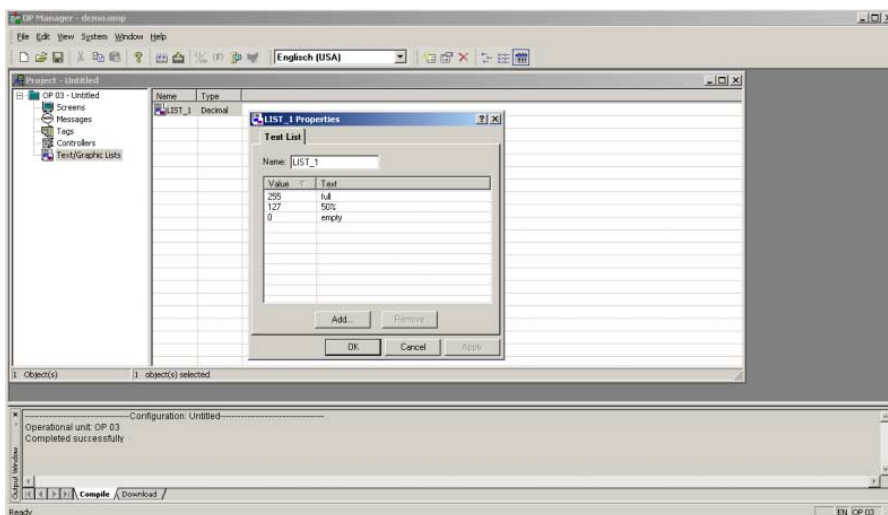

The reference to a tag is set in the screen object. Insert a field within a screen entry with **(F)**, select the property "Text" at "Display As", choose the according tag and your list object at "Text List".



Note!



Please regard that the output is restricted to texts that are assigned to a numeric value. Values without text assignment are displayed as "*****".

Integrated screens In delivery state, the CC has integrated standard screens that are described in the following:

Screen name	Usage
Change modes	Switch between Online-, Offline- and Transfer operation
Language	Language selection
Edit password	Here you may set the passwords for the different levels (Default: 100) and login via a password.
Time/Date	Date and time input
MPI address	Input of MPI address and baud rate

Emulate project

The OP-Manager provides you with an OP emulator that emulates an OP 03 on your Windows system. The usage of OP 03 is as the same as the usage of the CC 03. This allows you to test your project engineering without further hardware needs.

To start the emulator, you first have to save your project and compile it with . After the compilation you may start the emulator with . After every change of the program, you have to recompile it again. The emulator has the following structure:

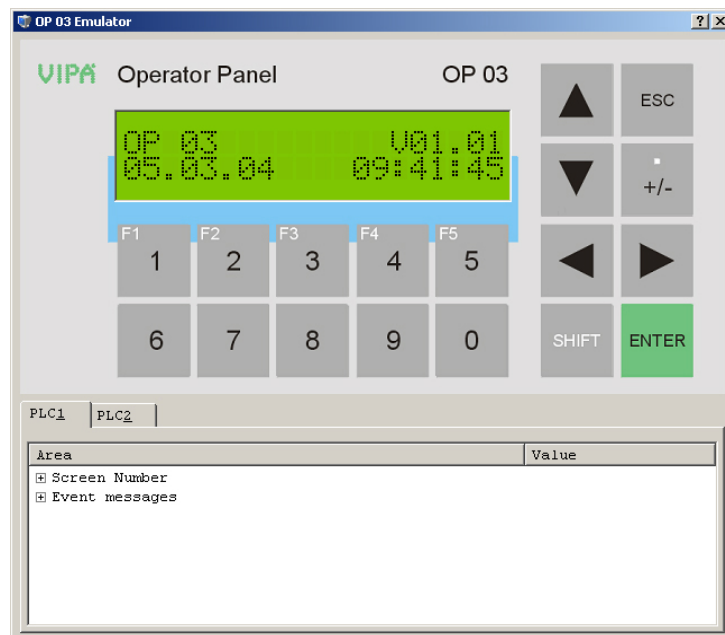

The upper half shows an original OP 03 with line display and keyboard. The lower half allows you to simulate an event on the internal CPU. Here you may jump to special screen entries by presetting the according values res. cause messages.

You may also use the menu option "Switch to Green Cable Mode" to directly connect your PC with the CC-CPU via Green Cable and test your programming on the emulator.

When your programming runs error-free on the emulator, you may transfer your project via MPI into your CC 03.



Note!

Please regard that the CPU emulation only works when you've created objects of the type "Screen Number" and "Event Messages" in your project group in the register "Area Pointer".

Commissioning

Preconditions

- A project has been configured by the OP-Manager and is ready for download.
- The CC 03 is powered by DC 24V.

Project transfer

For project transfer there are the following possibilities:

- Transfer online
- Transfer by MMC

The online project engineering requires a licensed version of the OP-Manager! More information may be found at the online help of the OP-Manager.

In the following the commissioning is described concerning these variants.



Note!

The CC 03 is always to be externally power supplied by DC 24V.

Transfer online

For online transfer the CC 03 is to be connected to the PC via the MPI interface. Here the VIPA Green Cable or a MPI adapter cable may be used.

Online connection by Green Cable

The Green Cable is available from VIPA and has the order number VIPA 950-0KB00. Connect as shown the RS232 interface of your PC and the MPI interface of the CC 03 by VIPA Green Cable.

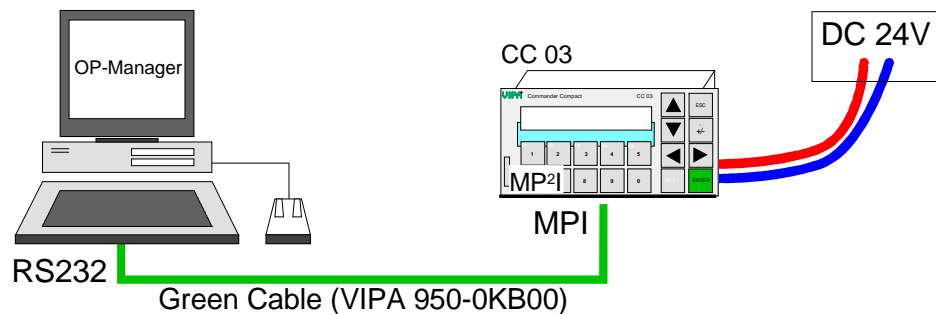

Attention!

- The Green Cable may exclusively deployed directly at the concerning MP²¹ jacks of the VIPA components (in between plugs are not permitted).
- The lengthening of the Green Cable with another Green Cable res. The combination with further MPI cables is not permitted and causes damages of the connected components! The Green Cable may only be lengthened with a 1:1 cable (all 9 Pins are connected 1:1).

Online connection
by MPI adapter
cable

With this transfer method the connection happens by a MPI adapter cable. The MPI converter cables are available from VIPA in different versions. At the PC side the MPI converter cable may be connected to the RS232 interface or the USB slot depending on the version.

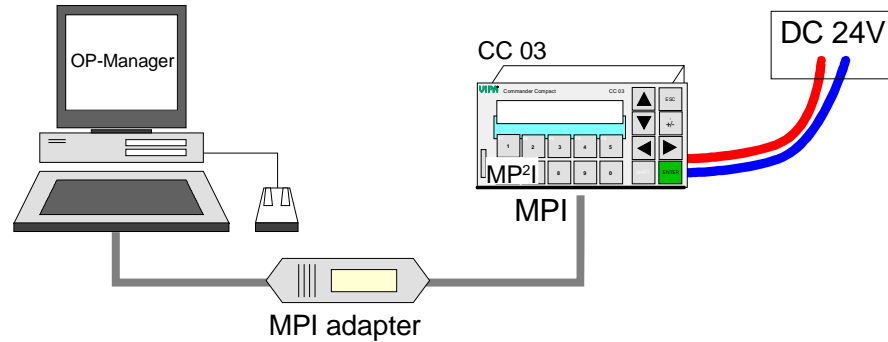

Prepare CC 03 for
data transfer

If the standard project is in the CC 03, you may set the OP mode "Operat. mode Transfer" via **System** > *OP-Mode* > **SHIFT** + **▼**, entering the password 100 and confirm with **ENTER**.

Now the CC 03 awaits data with "Ready for Transfer".

If the standard project is not yet present the setup menu may be connected with the following proceeding:

Push the key combination **▶** + **▼** + **ESC** on the CC 03 and turn it on again. Hold the keys until the CC 03 branches to the "Setup menu". Choose with **▼** "Perform Download from PC" and push **ENTER**. The CC 03 now awaits data with "Ready for Transfer".

This operation may always be aborted by **ESC**.

Start transfer at
OP-Manager

Load the OP-Manager with your project on your PC. You may only access the CC 03 online, if you work with a licensed version.





Call the transfer function with a click on .

Select MPI and set the transfer parameters like COM port, baud rate 38400 via **Settings...** and confirm your entry.

With **OK** configuration is confirmed and the transfer is started.

Transfer by MMC

With a licensed version of the OP-Manager there is the possibility to store your project as a MMC file. The file may be transferred to a MMC and read from MMC by the CC 03.

- Load your project in the OP-Manager on your PC and compile the project.
- Only a licensed version allows you to save your project as cfg-file using **File > Save Blocks as > MMC-File**.
- Copy this file to your MMC and rename it to vp3.cfg.
- Insert the MMC into the MMC slot of the CC 03.
- Push the key combination  +  + **ESC**, switch on the CC 03 and keep pushing the keys until the CC 03 branches to the "Setup-Menu".
- Choose "Perform Load Prog from MMC" by using  and push . The CC 03 announces "Storing configuration" and shows a reboot with "Restarting".
At wrong file name, the message "No program file found" occurs. With no plugged MMC, you receive the message "No MMC found".
- Now the MMC may be removed

Operation

After project transfer the CC 03 starts with the new project.

As soon as the power supply of the CC 03 is switched on it starts automatically with the project.

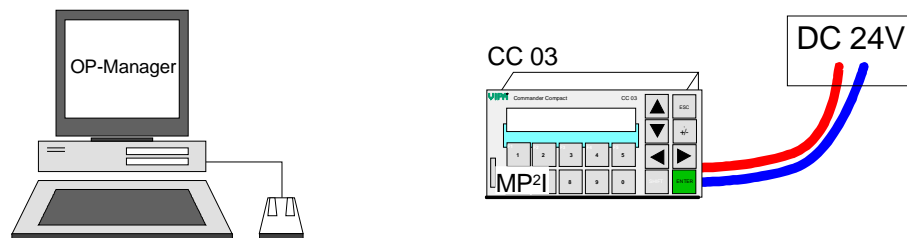

Startup in
delivery state

In delivery state or after an overall reset the CC 03 starts with the standard project of the OP-Manager.

Deployment operator panel

Switch on



The CC 03 starts as soon as it is powered by DC 24V.



Operation via keyboard





In delivery state, the CC 03 has a standard project where all functions required for the operation are integrated.

You reach the menu res. the pictures of a loaded project by using  after start-up.

For the navigation the following keys are available:



 res.  Navigation to previous res. next picture



 res.  Navigation to previous res. next picture



Push additionally  to navigate horizontal within a picture with  res.  and use  res.  to select for example at hexadecimal entry the according sign from the character set that you may not enter via the keyboard.

With  you leave and accept the date entry.



With  you abort an entry res. you come back to the next superordinated menu level.

The keys  1 ...  5 can be programmed in your project engineering tool as soft keys and may store picture related functions.



The access to the soft keys can be programmed with or without additional  key. This can be set via  in the OP-Manager from VIPA res. ProTool from Siemens.

 allows you to change the numeric sign res. with  +  to set a comma.

SETUP for data transfer, error diagnosis and contrast setting

Push the key combination  +  +  simultaneously before switching on the device to reach the SETUP where basic functions are at your disposal. Please keep pushing the keys until "Entering Setup ___" is monitored in the display.

Set display contrast

The setting of the display contrast is limited to the SETUP by using  +  res. .

Navigation

The navigation happens with  res. , the selection with .  leaves the SETUP again.

Data transfer and error diagnosis

The SETUP provides the following functions:





- **Setup default prog**

This function overwrites the current configuration with the basic configuration.

- **Download from PC**

This function prepares the CC to receive configuration data from the OP-Manager via MPI.

In delivery state the CC has the MPI address 2.

To control the MPI address you may leave the SETUP with 2x  and call the MPI address and the baud rate via  SYSTEM  >> 

MPI-ADR . These values may only be changed via a hardware configuration. To return to the SETUP you have to shut down the CC and turn it on again pushing the according key combination.

Select **Download from PC** and push 

After the end of the data transfer the data is checked and stored in the memory. If everything is OK, the CC starts with the new configuration.

- **Display error log**

This causes an output of all error codes stored in the CC.

- **Load from MMC**

This function allows you to transfer your configuration from a plugged MMC.

Chapter 3 Deployment CC 03 - CC-CPU

Overview This chapter includes all information required for the deployment of the CC-CPU, from the project engineering and addressing up to firmware update and commissioning.

Content	Topic	Page
	Chapter 3 Deployment CC 03 - CC-CPU.....	3-1
	Start-up behavior.....	3-2
	Principles of the address allocation	3-3
	CC-CPU - Project engineering	3-4
	CC-CPU - Operating modes.....	3-11
	CC-CPU - Overall reset.....	3-12
	Firmware update	3-14
	VIPA specific diagnostic entries	3-17
	CC-CPU - Test functions.....	3-19

Start-up behavior

Turn on power supply

After power supply is turned on, the CC-CPU switches to the operating mode that has been selected at the operating mode switch and the operating panel starts with the recent project res. with the standard project. Now you may transfer your PLC project from your CPU projecting tool into the CC-CPU via MPI res. plug in a MMC containing your PLC project (s7prog.wld) and request an overall reset. For the project engineering of the operator panel you may load an OP manager project online via MPI res. load it from MMC as vp3.cfg.

Overall reset

The following picture shows the approach:

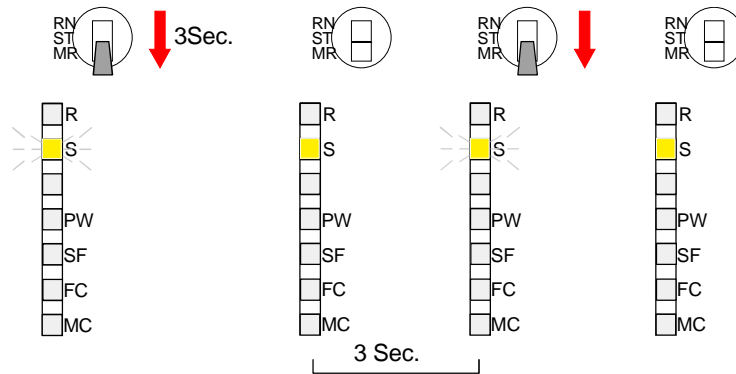

Note!

The transfer of the user application from the MMC into the battery buffered RAM respectively Flash memory of the CC-CPU takes always place after an overall reset or PowerON!

Default boot procedure, as delivered

When the CC-CPU is delivered it has been reset.

After a STOP→RUN transition the CC-CPU switches to RUN without program. If no project is loaded the operator panel starts with the standard project of the OP manager.

Start-up with empty accu

The accu is loaded directly via the integrated power supply by means of a load electronic and guarantees a buffer of ca. 30 days. If this time is exceeded, the accu may be totally discharged and the battery buffered RAM is erased.

Now the CC-CPU executes an overall reset and switches to STOP. This process is stored in the diagnostic buffer with the entry: "Start overall reset automatically (unbuffered POWER-ON)".

If a MMC is plugged in, the program on the MMC is transferred into the RAM. Otherwise the CC-CPU uses the program in the internal flash and transfers it to the RAM. With empty battery the operator panel automatically loads the standard project.

Principles of the address allocation

Overview

To provide specific addressing of the installed peripheral modules, certain addresses must be allocated in the CC-CPU.

At the start-up of the CC-CPU, the CPU automatically assigns the addresses of the I/O periphery starting at 0.

Signal states in the process image

The signal states of the lower addresses (0 ... 127) are saved in a special memory area called the *process image*.

The process image is divided into two parts:

- process image of the inputs (PII)
- process image of the outputs (PIQ)

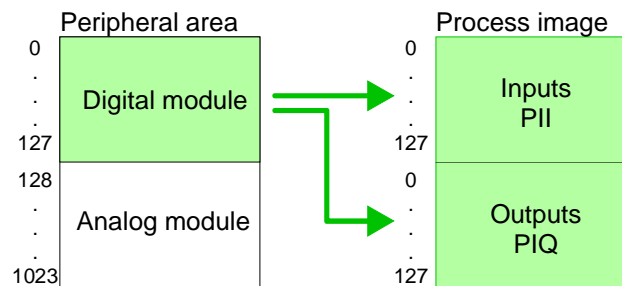

After every cycle the process image is updated.

Define addresses by hardware configuration

You may access the modules with read res. write accesses to the peripheral bytes or the process image.

To define addresses a hardware configuration may be used. For this, click on the properties of the according module and set the wanted address.

Automatic addressing

If you do not like to use a hardware configuration, an automatic addressing comes into force. First the internal I/O periphery is allocated by 3 bytes, each starting at 0, then the I/O periphery connected by bus extension are addressed.



Note!

Please regard that a read and write access to the same address different modules may be accessed.

The addressing ranges of digital and analog modules are different when they are addressed automatically.

Digital modules: 0 ... 127

Analog modules: 128 ... 1023

CC-CPU - Project engineering

General

The project engineering and the address allocation take place in the Siemens SIMATIC manager as a virtual PROFIBUS system. For the PROFIBUS interface is standardized also software sided, the functionality is guaranteed by including a GSD-file into the Siemens SIMATIC manager. Transfer your project into the CC-CPU via a serial connection to the MPI interface.

Preconditions

For the project engineering of your Micro-PLC the following requirements have to be fulfilled:

- Siemens SIMATIC manager is installed on PC res. PG.
- The GSD-file is included to the hardware configurator from Siemens.
- serial connection to the CC-CPU (e.g. "Green Cable" from VIPA).



Note!

The configuration of the CC-CPU requires a thorough knowledge of the Siemens SIMATIC manager and the hardware configurator from Siemens!

Installation of the Siemens hardware configurator

The hardware configurator is a component of the Siemens SIMATIC manager. It serves the project engineering. A list of modules that can be configured by this tool can be obtained from the hardware catalog.

For the deployment of the CC 03 the inclusion of GSD file from VIPA in the hardware catalog is required. You will find the CC 03 under the according order no. 603... in the GSD **VIPA_11x.GSD** for the System 100V.

Including the GSD file

- Copy the VIPA GSD-file into **VIPA_11x.GSD** your GSD directory ... \siemens\step7\s7data\gsd.
- Start the Siemens hardware configurator.
- Close all projects.
- Go to **Options** > *Install New GSD*.
- Enter **VIPA_11x.GSD**.
- Refresh the hardware catalog via **Options** > *update catalog*.

Now the modules of the VIPA System 100V and the CC 03 variants from VIPA have been integrated into the hardware catalog and are available for configuration. Here you may also find the extension modules that may be connected via the system bus expansion.

Steps of project engineering

To be compatible with the hardware configurator from Siemens, you have to configure the CC 03 as a virtual PROFIBUS system following these steps:

- Create a new project System 300.
- Include a profile rail from the hardware catalog.
- You find the PLC with PROFIBUS master in the hardware catalog under:
Simatic300/CPU-300/CPU315-2DP/6ES7 315-2AF03-0AB0.
- Add the CPU 315-2DP (6ES7 315-2AF03-0AB0).
- Assign a PROFIBUS address for your master (except 1).
- Click on DP and choose the operating mode "DP master" in the *object properties* and confirm with OK.
- Via a click on "DP" with the right mouse button, the context menu opens. Choose "Insert master system". Create a new PROFIBUS subnet via NEW.
- Attach the system "VIPA_CPU11x" to the subnet. The respective entries are located in the hardware catalog under *PROFIBUS DP > Additional Field Devices > IO > VIPA_System_100V*. Assign the PROFIBUS address 1 to this slave (VIPA_11x.GSD required). **PROFIBUS address 1 is mandatory!**
- Place your CC 03 in the configurator at slot 0 by dragging and dropping it at the according no. 603... from the hardware catalog to the slot 0. **Slot 0 is mandatory!**

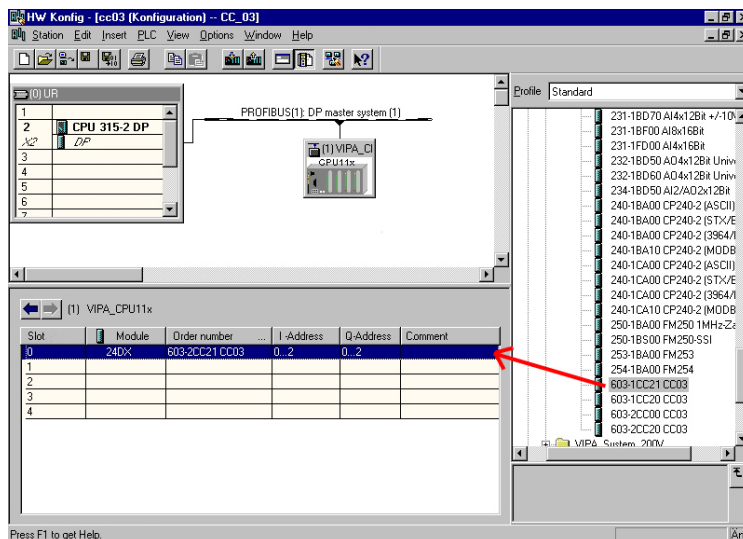

The address areas of the in-/output periphery and the slots of the system bus extension are created and may be changed at any time.

- Now you may include modules that may be connected via the system bus extension into the CC 03 via slot 1...4. For this, select the according module in the hardware catalog and place it to the according slot.
- Save your project.

Parameter setting

The CC-CPU has different parameters, that you may parameterize in the hardware configurator from Siemens via the concerning CPU-"properties".

- The adjustments, concerning the CC-CPU are to be found in the properties of the CPU 315-2 DP.
- Adjustments concerning the I/O periphery are to find under the "Properties" of the CC 03 like e.g. 603-2CC21.

The parameterization is to be described here.

CPU parameter

Via double click on the CPU 315-2 DP, the parameterization window of your CC-CPU may be reached.

Via the registers you have access to all parameters of the CC-CPU.

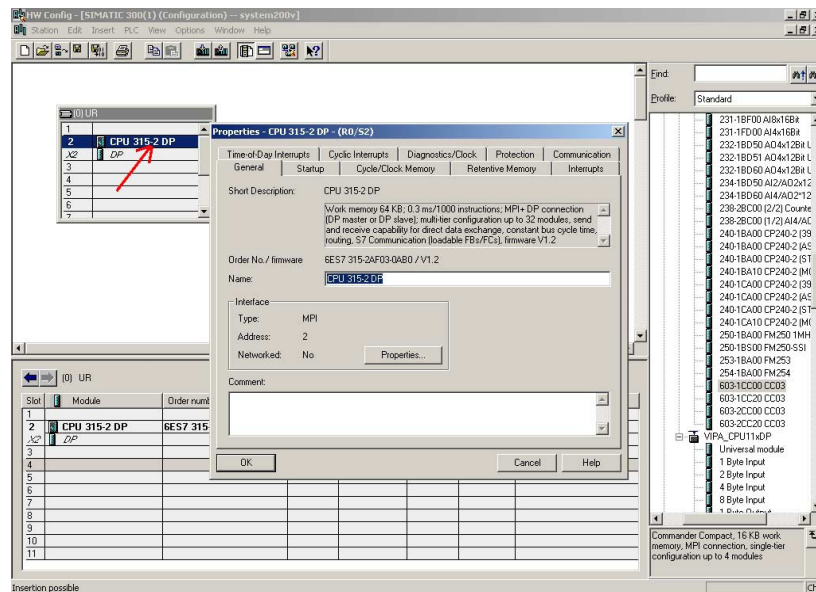

Supported parameters

The CC-CPU doesn't evaluate all parameters that you may parameterize in your projecting tool. The following parameters are evaluated by the CC-CPU at this time:

General :

- MPI address of the PLC
- baudrate (19.2kBaud, 187kBaud)
- maximum MPI address

Start-up:

- Start-up at scheduled configuration not equal...
- Ready message from module
- Transfer of parameters to...

Remanence :

- No. of bit memory bytes from MB0
- Number of S7-Timer from T0
- Number of S7-Counter from Z0

Protection:

- Protection level via password ...

Time alarm :

- OB10 : Execution Active
- Start date
- Time-of-day

Prompter alarm :

- OB35 : Execution

Cycle / pulse marker:

- Cycle watching time
- Cycle load due to communication
- OB85 call at periphery access error
- Timing flags with marker byte no.

Parameter of the I/O components

For the parameterization of the in-/output components of the CC 03 double click at slot 0 of the CC 03.

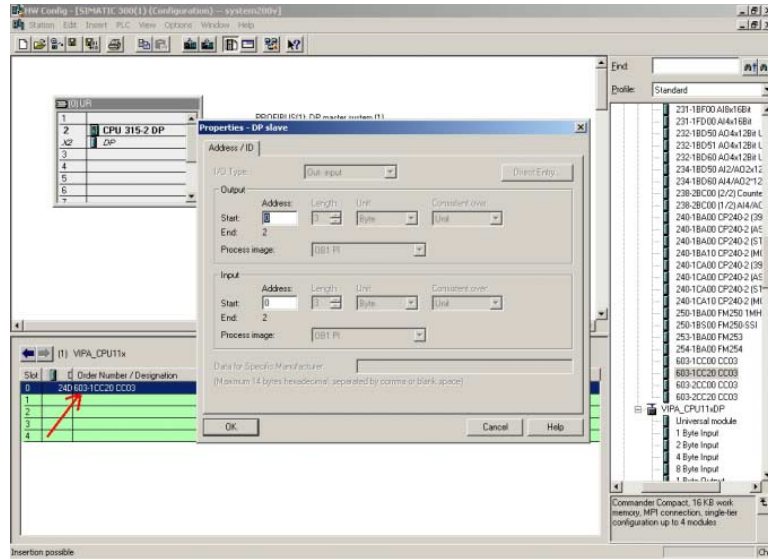

Now you may alter the address assignment of integrated in-/output components via "Address/ID" like e.g. for the 603-1CC21.

Parameter PROFIBUS

The register "Parameter" allows you to enter, for example for the CC 03 with integrated PROFIBUS-DP slave 603-2CC21, parameters for the PROFIBUS connection.

The PROFIBUS section maps its data area into the memory area of the CC-CPU. The assignment of the areas may be done in the register "Parameter".

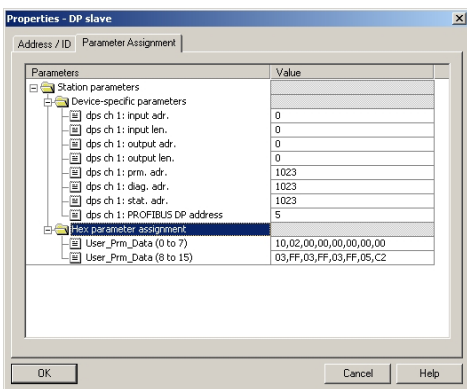

- Input addr.: Address for receive data via PROFIBUS
- Input length: Length of the data area of the receive data
- Output addr.: Address for send data via PROFIBUS
- Output length: Length of the data area of the send data
- Prm Addr.: Address of the 24Byte parameter data of the master
- Diag Addr.: Address of the 5Byte user diagnosis data
- Stat Addr.: Address of the 2Byte status area
- PROFIBUS DP Addr.: PROFIBUS address of the DP slave

More detailed information is to be found in the chapter "Deployment of the CC 03 under PROFIBUS".

Project transfer

There are 2 options for the transfer of your project into the CC-CPU:

- Transfer via MPI
- Transfer via MMC by means of a card reader

Transfer via MPI

The structure of a MPI network is in principal the same as the structure of a 1.5MBaud PROFIBUS network. That means, the same rules are valid and you use for both networks the same components.

Per default, the MPI network is working with 187.5kBaud.

Every participant at the bus identifies itself with an unique MPI address.

You connect the single participants via bus interface plugs and the PROFIBUS bus cable.

Terminating resistor

A cable has to be terminated with its ripple resistor. For this you switch on the terminating resistor at the first and the last participant of a network or a segment.

Please make sure that the participants with the activated terminating resistors are always provided with voltage during start-up and operation.

Approach

- Connect your PG res. your PC via MPI with your CC-CPU. If your PG has no MPI functionality you may use the VIPA "Green Cable" for a point-to-point connection. The VIPA "Green Cable" has the order no. VIPA 950-0KB00 and may only be used with VIPA components! Please regard the hints for the deployment of the Green Cable in chapter 1.
- Configure the MPI slot of your PC by monitoring them in the SIMATIC manager from Siemens under **Options** > *Set PG/PC Interface*. Set the parameters of your MPI network under "PC Adapter MPI" in the register MPI and enter your COM interface and the baud rate 38400 under "Local connection" (see following page).
- Now choose the components you want to transfer and start the transfer to the CC-CPU with **PLC** > *Upload Station*.
- For more security, install a MMC and transfer the application program to the MMC by clicking on **PLC** > *Copy RAM to ROM*.
During the write operation the "MC"-LED at the back side of the CC 03 is blinking. For internal reasons the message signaling completion of the write operation arrives too soon. The write operation is only complete when the LED has been extinguished.

Configure MPI for Green Cable

Hints for the configuration of a MPI interface are to find in the documentation of your programming software.

Here we only want to show the usage of the "Green Cable" from VIPA together with the programming tool from Siemens.

The "Green Cable" establishes via MPI a serial connection between the COM-interface of the PC and the MP²I jack of the CC-CPU.



Attention!

Please regard, that you may use the "Green Cable" exclusively at the MP²I jacks of the Components from VIPA!

- Start the SIMATIC manager from Siemens.
- Choose **Options** > *Set PG/PC Interface*
→ The following dialog window appears, where you may configure the according MPI slot:
- Choose the "PC Adapter (MPI)" in the list, probably you may have to add it first and Click on **Properties ...**.
→ In the following 2 sub dialogs you may configure your PC adapter like shown in the picture.

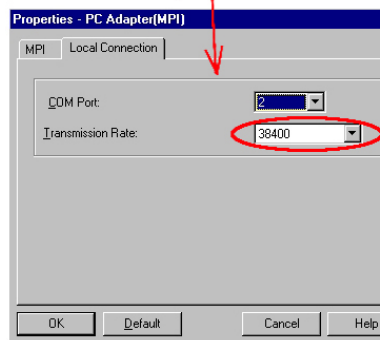
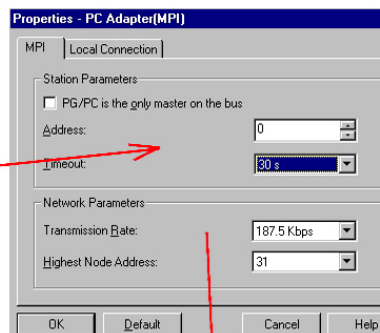
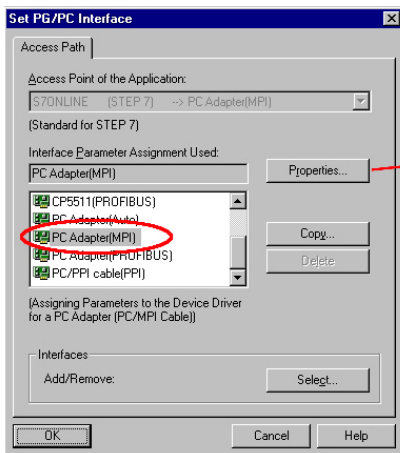

- In the Register "MPI", the **default settings** are recommended. Please regard that **Standard** has influence on the settings at "Local connection".
- At "Local connection" you choose the COM port and set, for the communication via MP²I, the **transfer rate at 38400bps**.
- Close both windows with **OK**.

Test

To test the connection, plug the VIPA Green Cable to the COM interface of your PC and to the MP²I jack of your CC-CPU.

Via **PLC** > *Display Accessible Nodes* you reach the CC-CPU with the preset MPI address 2.

Transfer via MMC

As external storage medium a MMC is deployed. The MMC (**M**ulti **M**edia **C**ard) serves as external transfer medium for programs and firmware for, among others, it provides the PC compatible FAT16 file system. With an overall reset or PowerON the MMC is automatically read. There may be stored several projects and sub-directories on a MMC storage module. Please consider that the current project is stored in the root directory and has one of the in the following described file names.

Transfer MMC→RAM→ROM

Always after an overall reset and PowerON the CC-CPU tries to load a user program from the MMC into the battery-buffered RAM or in the Flash memory. Here the following file names may be assigned to the project depending upon the desired functionality:

- **S7PROG.WLD**
After overall reset the user program S7PROG.WLD is transferred into the battery-buffered RAM.
- **S7PROGF.WLD (starting with Firmware-Version V. 3.8.6)**
After overall reset the user program S7PROG.WLD is transferred into the battery-buffered RAM and additionally into the Flash memory. An access to the Flash memory takes only place at empty battery of the buffer and when no MMC with user program is plugged-in.
- **AUTOLOAD.WLD**
After PowerON the user program AUTOLOAD.WLD is transferred into the battery-buffered RAM.

Transfer RAM→MMC→ROM

When the MMC has been plugged-in, the write command stores the content of the battery-buffered RAM as **S7PROG.WLD** at the MMC. The write command is controlled by means of the Siemens hardware configurator via **PLC > Copy RAM to ROM**. During the write process the "MC"-LED of the CC-CPU is blinking. When the LED expires the write process is finished. Simultaneously a write process into the internal Flash memory of the CC-CPU takes place.

Transfer control

After a write process onto the MMC, an according ID event is written into the diagnostic buffer of the CC-CPU. To monitor the diagnostics entries, you select **PLC > Module Information** in the Siemens SIMATIC manager. Via the register "Diagnostic Buffer" you reach the diagnostics window.

The following events may occur:

Event-ID	Meaning
0xE100	MMC access error
0xE101	MMC error file system
0xE102	MMC error FAT
0xE200	MMC writing finished
0xE300	Internal Flash writing finished

More information to the event IDs may be found at the end of this chapter.

Note!



If the size of the user application exceeds the user memory of the CC-CPU, the content of the MMC is not transferred to the CC-CPU. Before the transfer execute a compression, for this does not automatically happen.

CC-CPU - Operating modes

Overview

The CC-CPU there are 3 operating modes:

- Operating mode STOP
- Operating mode START-UP
- Operating mode RUN

Certain conditions in the operating modes START-UP and RUN require a specific reaction from the system program. In this case the application interface is often provided by a call to an organization block that was included specifically for this event.

Operating mode STOP

- The application program is not processed.
- If there has been a processing before, the values of counters, timers, marker and the process image are retained during the transition to the STOP mode.
- Outputs are inhibited, i.e. all digital outputs are disabled.
- RUN-LED off
- STOP-LED on

Operating mode START-UP

- During the transition from STOP to RUN a call is issued to the start-up organization block OB 100. The length of this OB is not limited. The processing time for this OB is not monitored. The start-up OB may issue calls to other blocks.
- All digital outputs are disabled during the start-up, i.e. outputs are inhibited.
- RUN-LED blinks
- STOP-LED off

When the CC-CPU has completed the start-up OB, it assumes the operating mode RUN.

Operating mode RUN

- The application program in OB 1 is processed in a cycle. Under the control of interrupts other program sections can be included in the cycle.
- All timers and counters being started by the program are active and the process image is updated with every cycle.
- The BASP-signal (outputs inhibited) is deactivated, i.e. all digital outputs are enabled.
- RUN-LED on
- STOP-LED off

CC-CPU - Overall reset

Overview

During the overall reset the entire user memory (RAM) of the CC-CPU is erased. Data located in the memory card is not affected.

You have 2 options to initiate an overall reset:

- initiate the overall reset by means of the function selector switch
- initiate the overall reset by means of the Siemens hardware configurator



Note!

You should always issue an overall reset to your CC-CPU before loading an application program into your CC-CPU to ensure that all blocks have been cleared from the CC-CPU.

Overall reset by means of the function selector

Condition

The operating mode of the CC-CPU is STOP. Place the function selector on the CC-CPU in position "ST" → The S-LED is on.

Overall reset

- Place the function selector in the position MR and hold it in this position for app. 3 seconds. → The S-LED changes from blinking to permanently on.
- Place the function selector in the position ST and switch it to MR and quickly back to ST within a period of less than 3 seconds. → The S-LED blinks (overall reset procedure).
- The overall reset has been completed when the S-LED is on permanently. → The S-LED is on.

The following figure illustrates the above procedure:

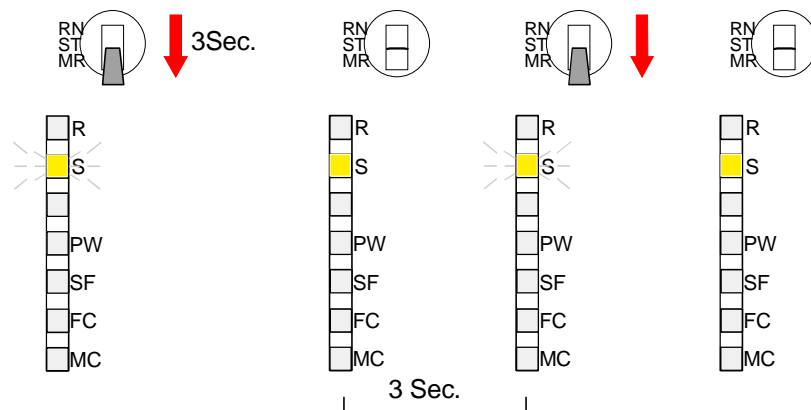

- Automatic reload** At this point the CC-CPU attempts to reload the parameters and the program from the memory card. → The lower LED (MC) blinks.
When the reload has been completed the LED is extinguished. The operating mode of the PLC will be STOP or RUN, depending on the position of the function selector.
- Overall reset via hardware configurator from Siemens** *Condition*
The operating mode of the CC-CPU has to been stopped.
You may place the CC-CPU in STOP mode by the menu command **PLC > Operating mode**.
- Overall reset*
You may request the overall reset by means of the menu command **PLC > Clear/Reset**.
In the dialog window you may place your CC-CPU in STOP mode and start the overall reset if this has not been done as yet.
The S-LED blinks during the overall reset procedure.
When the S-LED is on permanently, the overall reset procedure has been completed.
- Automatic reload** At this point the CC-CPU attempts to reload the parameters and the program from the memory card. → The "MC"-LED blinks.
When the reload has been completed, the LED is extinguished. The operating mode of the PLC will be STOP or RUN, depending on the position of the function selector.

Firmware update

Overview

The CC 03 offers you the option to execute a firmware update via MMC using the reserved file name *firmware.bin* or the update software and the Green Cable from VIPA.

The last recent firmware versions can be downloaded in the service area of www.vipa.de.



Attention!

Please be very careful with loading a new firmware. Under certain circumstances you may destroy your CC 03, for example if the voltage supply is interrupted during transfer or if the firmware file is defective.

In this case, please call the VIPA hotline!

Please also regard that the update version has to be different from the existing version, otherwise no update will happen.

Read firmware version

If you didn't execute a firmware update before, you may find the recent firmware version on the label on the backside of your CC 03.

To download the firmware file, order no. and version no. (HW) are required. These ID numbers mark the storage directory of the concerning firmware. For example: The firmware file of a CC 03 with the order no. 603-2CC21 and HW no. 1 is stored under the file name 603-2cc21_a1.xxx (xxx is the firmware version).

Proceeding

- Go to www.vipa.de.
- Click at Service / Support > Downloads > Firmware and navigate via "HMI" to the firmware for your CC.
- Extract the zip-file into the wanted directory on your PC.
- If you want to execute the update with the Green Cable, the VIPA "Updater" is required that you may download under "Firmware" in the download area. Start the "Updater" with `cpu_up.exe`.

Transfer firmware from MMC into PLC

There may be several projects and directories on one MMC. Please regard that the recent firmware file for the CC 03 has to be stored in the root directory, i.e. on the most upper level. To enable the identification of this file as firmware, rename the file into **firmware.bin**.

- Install your MMC reading device and plug in a MMC. Transfer the file firmware.bin to your MMC.
- Set the RUN-STOP lever of the CC 03 in position STOP.
- Turn off the power supply.
- Plug the MMC with the firmware file into the CC-CPU. Please take care of the plug-in direction of the MMC.
- Turn on the power supply.
- After a short boot time, the alternate blinking of the LEDs SF and FC shows that a file has been found on the MMC.
- Start the transfer of the firmware by tipping the RUN/STOP lever into position MRST within 10s. The PLC shows the transfer via a LED running light.
- During the update process, the LEDs SF, FC and MC are blinking alternately. This process may last several minutes.
- The update is ready and error free when all CC-CPU-LEDs are on. At fast blinking, an error has occurred.

Firmware update via Green Cable and "Updater"

To update the firmware via Green Cable, the Green Cable from VIPA and the software tool "Updater" are required. The software can be downloaded from www.vipa.de. Load the Updater and extract the zip-file into a directory of your PC.

Start the Updater with PLC_up.exe. The following dialog window appears:

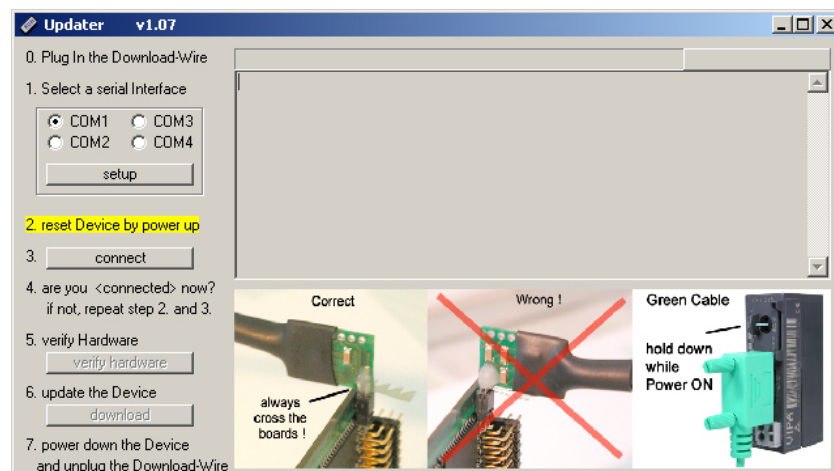

A more detailed description of the approach is on the following page.

Continued firmware update via Green Cable and "Updater"

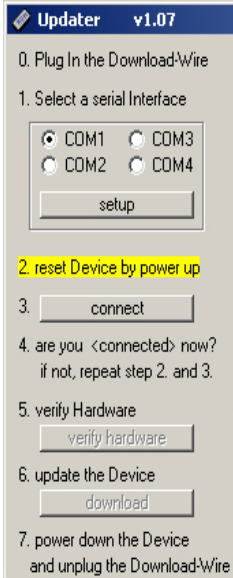

- to 0. Connect the COM interface of the PC and the MP²I jack of your CC 03 via the Green Cable.
- to 1. Type the COM interface (you should not alter the setup).
- to 2. Turn off the CC, hold the RUN/STOP lever in position MRST and turn on the CC.

Now the CC 03 is ready for the firmware update and monitors this by turning all LEDs on.

- to 3. Click on **connect** in the Updater.
- to 4. A connection to the CC 03 is established and shown via the message [connected].

If an error message appears instead, repeat the steps above with another COM interface.

- to 5. At error free connection click on **verify hardware**.
Your CC 03 is now prepared for data transfer.

- to 6. A click on **download** opens a file selection window. Choose the according firmware and start the download with **Open**.

If the error message "The selected file doesn't fit to your hardware" appears you may have been tried to download a firmware that is not compatible to your CC 03. With a valid firmware version, the update process starts. This process may last several minutes and is shown in a process bar.

After the download, the following window should appear:

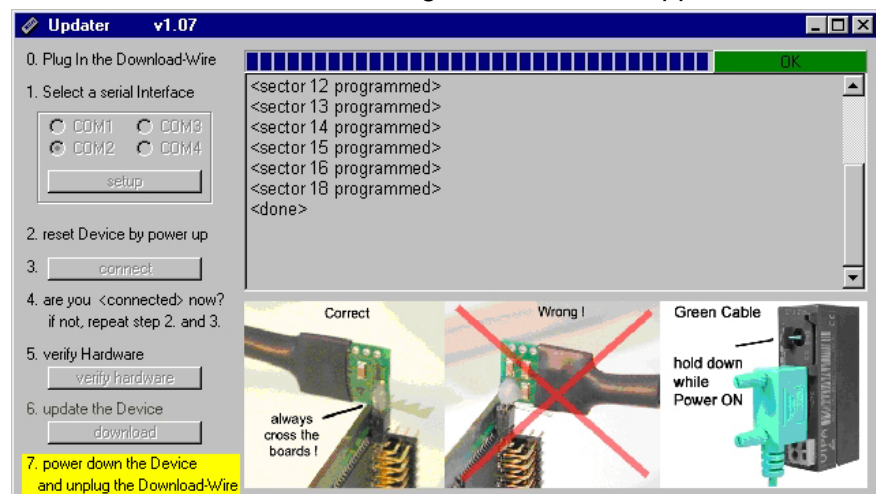

- to 7. Turn off the power supply of your CC 03, disconnect the Green Cable and turn on the power supply again. Now the CC 03 is ready with the new firmware.

If your CC 03 does not start anymore, an error occurred during the firmware update. Please call the VIPA hotline.

VIPA specific diagnostic entries

Entries in the diagnostic buffer

You may read the diagnostic buffer of the CC-CPU via the Siemens manager. Besides of the standard entries in the diagnostic buffer, the VIPA CPUs support some additional specific entries in form of event-IDs.

Monitoring the diagnostic entries

To monitor the diagnostic entries you choose the option **PLC > Module Information** in the Siemens SIMATIC manager. Via the register "Diagnostic Buffer" you reach the diagnostic window:

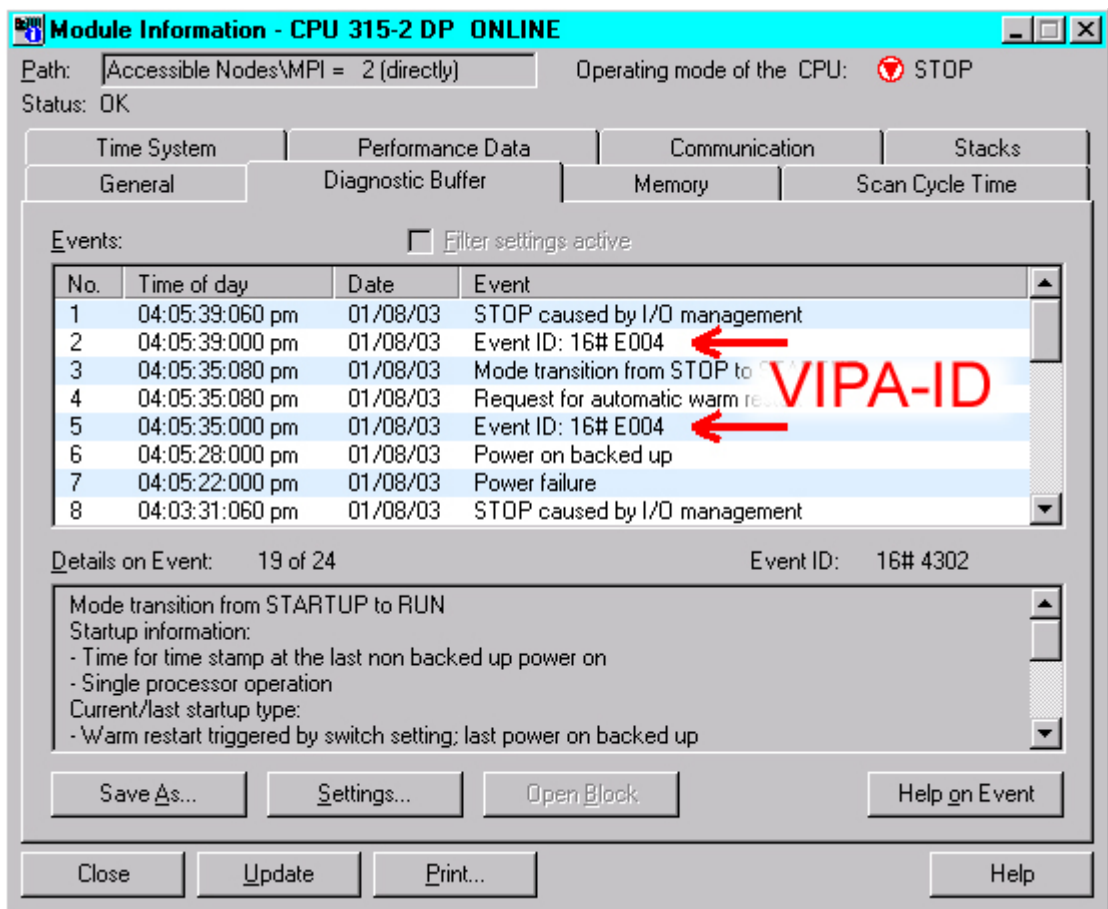

The diagnosis is independent from the operating mode of the CC-CPU. You may store a max. of 100 diagnostic entries in the CC-CPU.

The following page shows an overview of the VIPA specific Event-IDs.

Overview of the Event-IDs

Event-ID	Description
0xE003	Error at access to I/O devices Zinfo1: I/O address Zinfo2: Slot
0xE004	Multiple parameterization of a I/O address Zinfo1: I/O address Zinfo2: Slot
0xE005	Internal error – Please contact the VIPA-Hotline!
0xE006	Internal error – Please contact the VIPA-Hotline!
0xE007	Configured in-/output bytes do not fit into I/O area
0xE008	Internal error – Please contact the VIPA-Hotline!
0xE009	Error at access to standard back plane bus
0xE010	Not defined module group at backplane bus recognized Zinfo2: Slot Zinfo3: Type ID
0xE011	Master project engineering at Slave-CPU not possible or wrong slave configuration
0xE012	Error at parameterization
0xE013	Error at shift register access to VBUS digital modules
0xE014	Error at Check_Sys
0xE015	Error at access to the master Zinfo2: Slot of the master (32=page frame master)
0xE016	Maximum block size at master transfer exceeded Zinfo1: I/O address Zinfo2: Slot
0xE017	Error at access to integrated slave
0xE018	Error at mapping of the master I/O devices
0xE019	Error at standard back plane bus system recognition
0xE01A	Error at recognition of the operating mode (8 / 9 Bit)
0xE0CC	Communication error MPI / Serial
0xE100	MMC access error
0xE101	MMC error file system
0xE102	MMC error FAT
0xE104	MMC error at saving
0xE200	MMC writing finished (Copy RAM to ROM)
0xE210	MMC reading finished (reload after overall reset)
0xE300	Internal Flash writing ready (Copy RAM to ROM)
0xE310	Internal Flash reading ready (reload after battery failure)

CC-CPU - Test functions

Overview

For troubleshooting purposes and to display the status of certain variables you can access certain test functions via the menu item **Debug** of the Siemens SIMATIC manager.

The status of the operands and the VKE can be displayed by means of the test function **Debug > Monitor**.

You can modify and/or display the status of variables by means of the test function **PLC > Monitor/Modify variables**.

Debug > Monitor

This test function displays the current status and the VKE of the different operands while the program is being executed.

It is also possible to enter corrections to the program.



Note!

When using the test function "Monitor" the PLC must be in RUN mode!

The processing of statuses can be interrupted by means of jump commands or by timer and process interrupts. At the breakpoint the CC-CPU stops collecting data for the status display and instead of the required data it only provides the PG with data containing the value 0.

For this reason, jumps or time and process interrupts can result in the value displayed during program execution remaining at 0 for the items below:

- the result of the logical operation RLO
- Status / AKKU 1
- AKKU 2
- Condition byte
- absolute memory address SAZ. In this case SAZ is followed by a "?".

The interruption of the processing of statuses does not change the execution of the program. It only shows that the data displayed is no longer valid from that point on where the interrupt occurred.

PLC >
*Monitor/Modify
variables*

This test function returns the condition of a selected operand (inputs, outputs, flags, data word, counters or timers) at the end of program execution.

This information is obtained from the process image of the selected operands. During the "processing check" or in operating mode STOP the periphery is read directly from the inputs. Otherwise only the process image of the selected operands is displayed.

Control of outputs

This function allows you to set the outputs to a wanted signal state. Here the command output lock for the outputs is released ignoring the user application. The process image is not altered. You may use this function to control the cabling and the correct operation of output modules.



Attention!

At direct access of outputs you must ensure safety for humans and machine.

Control of variables

The following variables may be modified:

I, Q, M, T, C and D.

The process image of binary and digital operands is modified independently of the operating mode of the CC-CPU.

When the operating mode is RUN the program is executed with the modified process variable. When the program continues they may, however, be modified again without notification.

Process variables are controlled asynchronously to the execution sequence of the program.

Chapter 4 Deployment CC 03DP with PROFIBUS DP

Overview Content of this chapter is the deployment of the CC 03DP with PROFIBUS. It includes all information required for deploying an intelligent PROFIBUS DP slave.

Content	Topic	Page
	Chapter 4 Deployment CC 03DP with PROFIBUS DP	4-1
	Principles.....	4-2
	Project engineering CC 03DP	4-7
	DP slave parameters.....	4-12
	Diagnostics functions	4-15
	Status message internal to CC-CPU	4-18
	PROFIBUS installation guidelines	4-20
	Commissioning.....	4-25

Principles

General

PROFIBUS is an international open field bus standard for building, manufacturing and process automation. PROFIBUS defines the technical and functional properties of a serial field bus system that can be used to create a network of distributed digital field-automation equipment on the lower (sensor-/drive level) to middle performance level (process level).

PROFIBUS comprises various compatible versions. The specifications contained in this description refer to PROFIBUS DP.

PROFIBUS DP

PROFIBUS DP is particularly suitable for applications in production automation. DP is very fast, offers Plug'n'Play and is a cost-effective alternative to parallel cabling between PLC and the distributed periphery. PROFIBUS DP is conceived for high-speed data exchange on the sensor-drive level. This is where central controllers like PLCs communicate via fast, serial connections with distributed in- and output devices.

During a single bus cycle the master reads the input values from the various slaves and writes new output information into the slaves.

Master and Slaves

PROFIBUS distinguishes between active stations (masters) and passive stations (slaves).

Master equipment

Master equipment controls the data traffic on the bus. There may be also several masters at one PROFIBUS. This is referred to as multi-master operation. The bus protocol establishes a logical token ring between the intelligent devices connected to the bus.

A master can send unsolicited messages if it has the bus access permission (Token). In the PROFIBUS protocol these masters are also referred to as active stations.

Slave equipment

Typical slave equipment holds data of peripheral equipment, sensors, drives and transducers. The VIPA PROFIBUS couplers are modular slave devices, which transfer data between the periphery and the leading master.

These devices do not have bus access permission in accordance with the PROFIBUS standard. They can only acknowledge messages or transfer messages to a master if requested by the respective master. Slaves occupy a very limited part of the bus protocol. Slaves are also referred to as passive stations.

Communication

The bus communication protocol provides two procedures for accessing the bus:

Master to master

Communications with the master is also referred to as token passing procedure. Token passing guarantees that the station receives access permission to the bus. This access right to the bus is passed between the stations in form of a "token". A token is a specific message that is transferred via the bus.

When a master is in the possession of the token it also has the access right to the bus and can communicate with all other active and passive stations. The token retention time is defined when the system is being configured. When the token retention time has expired the token is passed along to the next master that acquires the bus access rights with the token so that it can communicate with all other stations.

Master slave procedure

Data is exchanged in a fixed repetitive sequence between the master and the slaves assigned to the respective master. When you configure the system you define which slaves are assigned to a certain master. You can also specify which DP slave is included in the cyclic exchange of application data and which ones are excluded.

The master-slave data transfer is divided into parameterization, configuration and data transfer phases. Before a DP slave is included in the data transfer phase the master verifies during the parameterization and configuration phase, whether the specified configuration agrees with the effective configuration. This verification process checks the device type, format and length as well as the number of inputs and outputs. This provides you with effective protection against configuration errors.

The master handles application data transfers independently. In addition you can also send new configuration data to a bus coupler.

If in the status DE "Data Exchange" the master is sending new basic data to the slave and the responding telegram of the slave transfers the recent input data to the master.

The principle of data transfer operations

The data exchange between the DP master and the DP slave is performed in a cycle using send and receive buffers.

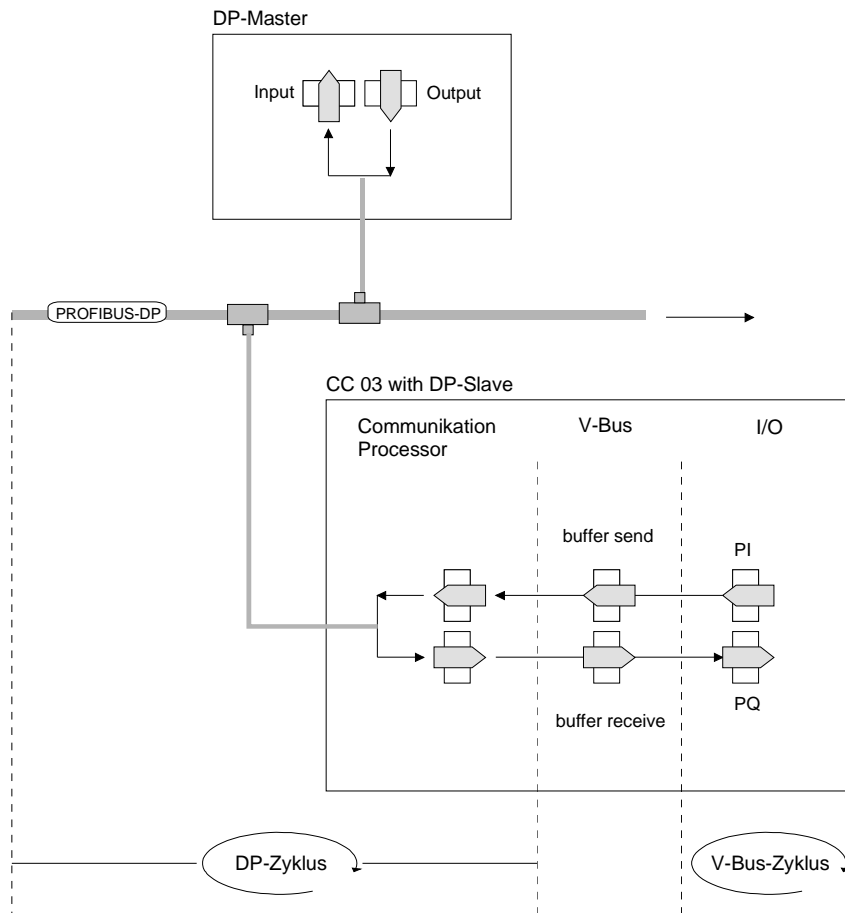

PI: Process image of the Inputs
 PQ: Process image of the Outputs

V-Bus cycle

In one V-Bus cycle (i.e. VIPA backplane bus) all input data of the CC-CPU are collected in the PII and all output data from the PIQ are transferred to the output modules. After the data exchange is completed, the PII is transferred to the sending buffer (buffer send) and the content of the input buffer (buffer receive) is transferred to PIQ.

DP cycle

In one PROFIBUS cycle the master contacts all its slaves with a data exchange. There the memory areas assigned to the PROFIBUS are written res. read.

Afterwards the DP master transmits data of the input area to the receive buffer of the communication processor and the data of the send buffer is transferred into the PROFIBUS output area.

The DP master to DP slave data exchange on the bus is repeated cyclically and does not depend on the V-Bus cycle.

V-Bus cycle \leq DP cycle	<p>To guarantee a simultaneous data transfer the V-Bus cycle time should always be same or lower than the DP cycle time.</p> <p>In the delivered GSD you'll find the parameter min_slave_interval = 3ms. Thus guarantees that the PROFIBUS data on the V-Bus is updated at least every 3ms. Though you are allowed to execute one Data Exchange with the slave every 3ms.</p>
Data consistency	<p>Data is referred to as being consistent, if it has the same logical contents. Data that belongs together is: the high- and low-byte of an analog value (word consistency) and the control and the status byte with the respective parameter word required to access the registers.</p> <p>The data consistency of communication between periphery and control is basically secure within the complete range.</p> <p>PROFIBUS guarantees the consistency with the required length.</p> <p>Please take care for the correct type to take over the consistent data from the PROFIBUS master into the CPU.</p> <p>Hints for this are to be found in the manual of your PROFIBUS master.</p>
Restrictions	<p>When a high-level master fails this is not recognized automatically by the CPU. You should always pass along a control byte to indicate the presence of the master thereby identifying valid master data.</p>
Diagnosis	<p>There is a wide range of diagnosis functions at PROFIBUS DP to allow a fast error localization. The diagnostics data are broadcasted by the bus system and summarized at the master.</p>

Transfer medium

As transfer medium the CC 03 PROFIBUS system uses an isolated twisted-pair cable based upon the RS485 interface or a duplex photo cable. The transfer rate is for both methods max. 12Mbaud.

PROFIBUS DP via RS485

The RS485 interface is working with voltage differences. Though it is less irritable from failures than a voltage or a current interface. The network may only be built up in linear structure. Your CC 03 includes a 9pin "DP" slot where you connect the CC 03DP slave into the PROFIBUS network as a slave.

The bus structure under RS485 allows an easy connection res. disconnection of stations as well as starting the system step by step. Later expansions don't have any influence on stations that are already integrated. The system realizes automatically if one partner had a fail down or is new in the network.

Addressing

Every partner of the PROFIBUS network has to identify itself with a certain address. This address may be exist only one time in the bus system and has a value between 1 and 125.

At the CC 03 you choose the address via your software tool.

GSD files

To configure the slave connections in your own configuration tool, you've got all the information about your VIPA-modules in form of an electronic data sheet file.

Structure and content of this file are dictated by the PROFIBUS User Organization (PNO) and can be seen there.

Install this file in your configuration tool. Look for more information below under "Project engineering CC 03DP" or in the online help of the according tool.

The following GSD-files are required:

GSD	required for
VIPA_11x.GSD	project engineering I/O components of CC 03 as "CPU 11x" at slave side
VIPA04Dx.GSD	connection CC 03DP as "CPU 11xDP" to master system

Project engineering CC 03DP

Overview

In opposite to a stand-alone slave, the CC 03 with DP slave is provided with an "intelligent PROFIBUS coupler".

The "intelligent coupler" processes data that are stored in an in- res. output area of the CPU. This area and an area for status and diagnostics data are set in the properties of the 603-2CC2x. For in- res. output data, separated memory areas are used. These areas are handled with your PLC program.

Due to the system, the address ranges that are occupied by the coupler are not monitored in the Siemens hardware configurator.

Please take care to avoid address overlaps.



Note!

For configuring the CPU and the PROFIBUS DP master a thorough knowledge of the SIMATIC manager and the hardware configurator from Siemens is required!

Configuration in the SIMATIC manager from Siemens

The address allocation and the parameterization take place in the SIMATIC manager from Siemens by means of a virtual PROFIBUS system. By including a GSD the functionality of the CC 03 is available in the SIMATIC Manager from Siemens.

Steps of the CC 03DP configuration

To be compatible with the SIMATIC manager from Siemens, you have to follow these steps:

- Create a complete CPU 315-2DP with DP master system (address 2)
- Add a PROFIBUS slave "VIPA_CPU11x" with address 1 (VIPA_11x.GSD required)
- Include the CC 03 (603-2CC21) at slot 0 of the slave.
- Select PROFIBUS parameters for the CC 03.
- Enter I/O periphery parameters.
- Transfer project via MPI into the CC 03.

Steps of the master configuration

At the master you have to execute the following steps:

- Create CPU with DP master system (address 2)
- For the CC 03 is in reaction equal to the CPU 11x DP, you have to add the PROFIBUS DP slave VIPA_CPU11xDP (VIPA04Dx.GSD required).
- Enter the PROFIBUS in- and output areas starting with slot 0 in Byte res. words.

Relation between master and slave

The following illustration summarizes the project engineering at the slave and the master:

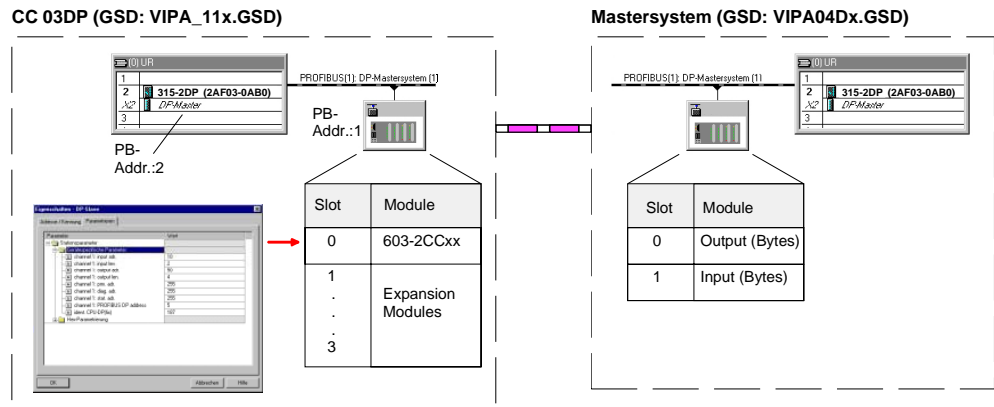

Configuration CC 03DP

The following section describes the single steps for the slave project engineering.

Conditions

For the project engineering of the CC 03DP in a master system the following conditions must be met:

- SIMATIC manager from Siemens is installed.
- GSD-file of the CC 03DP is included in the hardware configurator.
- Transfer possibilities between project engineering tool and CPUs are available.

Install hardware configurator from Siemens

The hardware configurator is part of the SIMATIC manager from Siemens. It is used for project engineering. The modules that may be parameterized are listed in the hardware catalog.

For the deployment of the PROFIBUS DP slave of the CC 03DP, you have to include the modules in the hardware catalog via the GSD-file from VIPA.

GSD: Include VIPA_11x.GSD

Start the hardware configurator from Siemens. To include a new GSD, no project may be open.

Open the file window for installing GSDs via **Options > Install GSD...** Insert the delivered data medium and select the according GSD. The installation starts with [Open].

Normally you'll find the modules from VIPA installed via the GSD in the hardware catalog under *PROFIBUS DP > Additional field devices > I/O > VIPA*.

Create a virtual PROFIBUS system

- Create a new project system 300 and add a profile rail from the hardware catalog.
- Insert the CPU 315-2DP. This PLC with PROFIBUS master is to find in the hardware catalog at: *Simatic300 > CPU-300 > CPU315-2DP > 6ES7 315-2AF03-0AB0*.
- Assign the PROFIBUS address 2 to your master.
- Click on "DP" and choose the operating mode "DP master" under *Object properties*. Confirm with OK.
- Via right-click on "DP", the context menu opens. Choose "Add master system". Create a new PROFIBUS subnet via NEW.

The following picture shows the created master system:

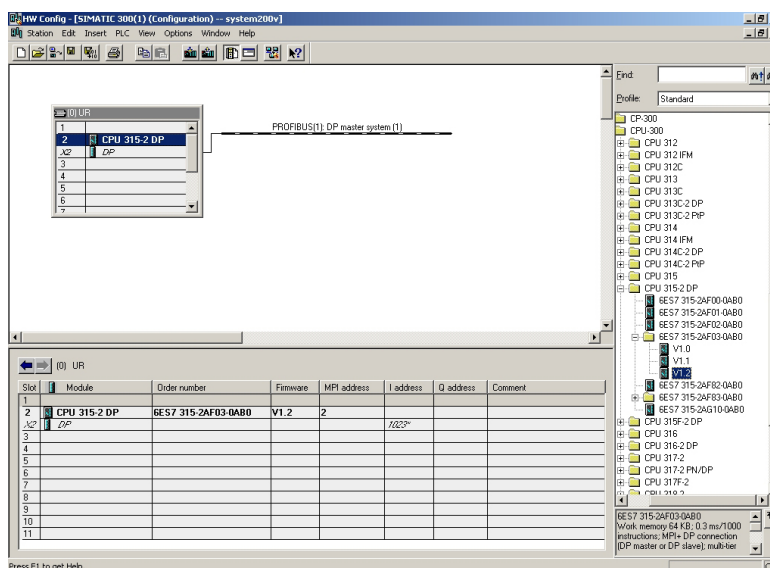

Configure CC 03

To be compatible with the SIMATIC manager from Siemens, you have to include the CPU 11xDP explicitly

- Add the system CC 03DP to your subnet. This is in the hardware catalog at *PROFIBUS DP > Additional field devices > I/O > VIPA_System_100V*. Assign the PROFIBUS address 1 to the DP slave.
 - Place your CC 03DP (603-2CC21) from VIPA in the hardware configurator at slot 0.
- The slot 0 is mandatory!**

Continue configure CC 03

- Parameterize the in-/output periphery.

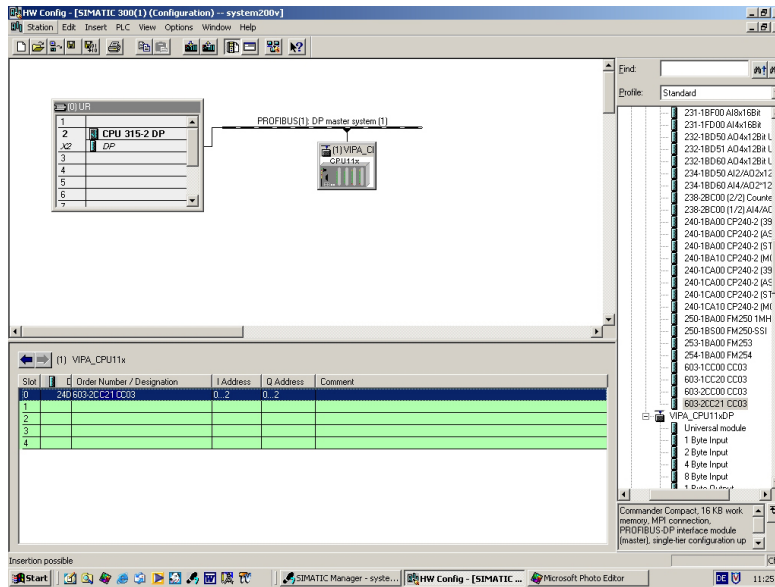

- The PROFIBUS section shows its data areas in the memory area of the CC-CPU. The allocation of these areas is fixed at the properties of the CC 03DP. Via a double-click on the 603-2CCxx the dialog window for parameterization of the data areas for the PROFIBUS slave may be opened. More detailed information may be found in the following at "DP slave parameters".



Attention!

Please take care of identical data areas length values at master and slave configuration.

The data areas that are occupied in the CPU by the PROFIBUS section may only be monitored in the CPU parameter window.

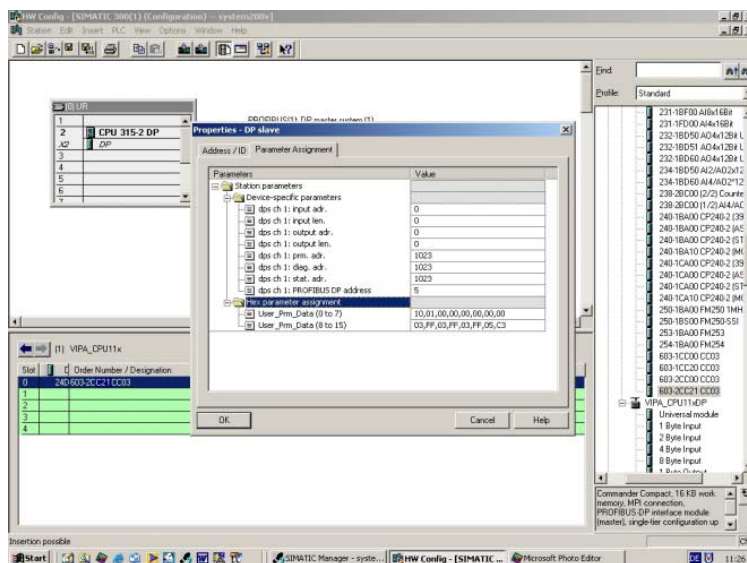

- Save your project.
- Transfer your project via MPI into the CC 03DP.

Project engineering in a master system

To engineer a master system on a higher level, you have to include the GSD: VIPA04Dx.GSD.

- Start your configuration tool and project a PROFIBUS DP master that is leading your CC 03DP.
- Add a DP slave system "VIPA_CPU11xDP" to the master. This is to find in the hardware catalog under:
PROFIBUS DP > Additional field devices > I/O > VIPA > VIPA_System_100V.
- Select a valid PROFIBUS address for your DP slave.
- Assign memory areas of the PLC address range to the PROFIBUS section for the inputs and outputs in form of "modules". Input and output section always need an uninterrupted block of addresses!

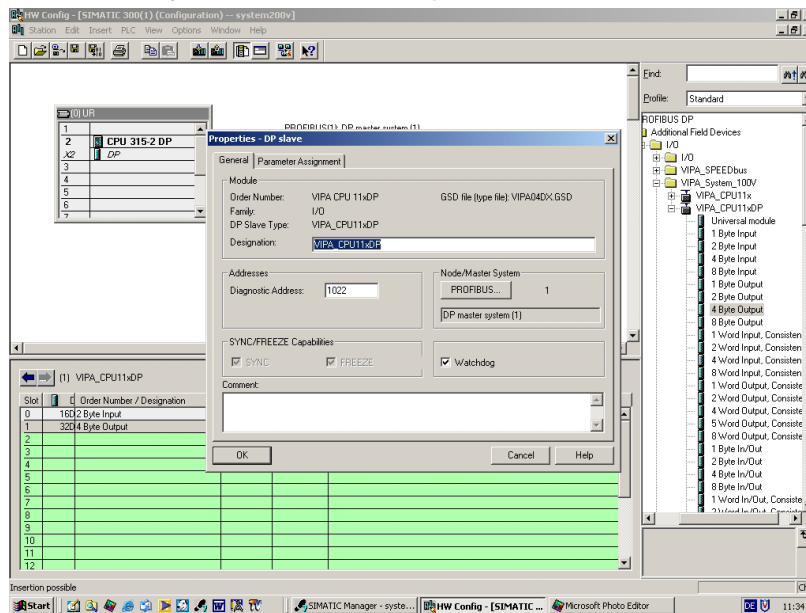

- Save your project and transfer it into the CPU of your master system.



Note!

When your DP master system is a System 200V from VIPA, you may parameterize the directly plugged-in modules by adding a "DP_200V_2" slave system.

To enable the VIPA-CPU to recognize the project as central system, you have to assign the PROFIBUS address 1 to the "DP_200V_2" slave system!

When deploying an IM 208 PROFIBUS DP master, please ensure that this has a firmware version > V 3.0; otherwise this is not compatible with the CPU 21x with a firmware version >V 3.0. The firmware version is to find on the label on the backside of every module.

DP slave parameters

Overview

"Intelligent" slave means that the PROFIBUS section includes its data areas into the memory range of the CPU. The allocation of the ranges takes place in the "Properties" of the CC 03DP.

The in- res. output areas have to be supported with an according PLC program.



Attention!

The length entries for the input and output area have to be congruent with the Byte entry at the master project engineering. Otherwise no PROFIBUS communication is possible (slave failure)!

CC 03DP (GSD: VIPA_11x.GSD)

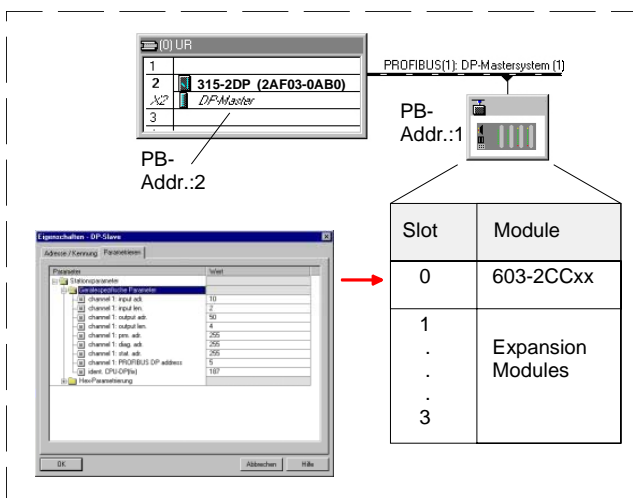

Mastersystem (GSD: VIPA04Dx.GSD)

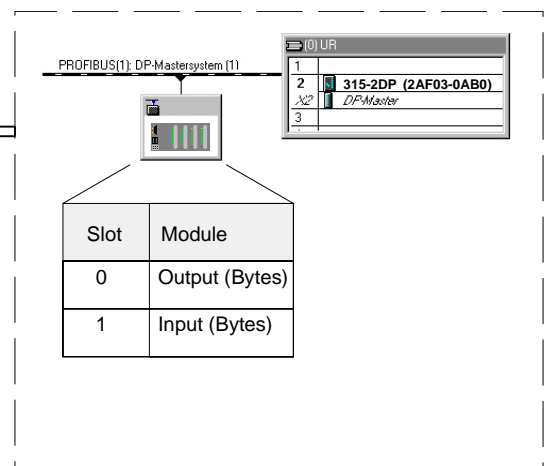

Release memory in the CPU

When you enter a length of 0, the according data do not occupy memory space in the CPU.

Entering 1023 (memory limit) at the parameters PRN, DIAG and STAT you may also release memory areas of the CPU.

Description parameter data

Via a double-click on the CC 03DP in the hardware configurator, the dialog window for the parameterization of the data areas for the PROFIBUS slave:

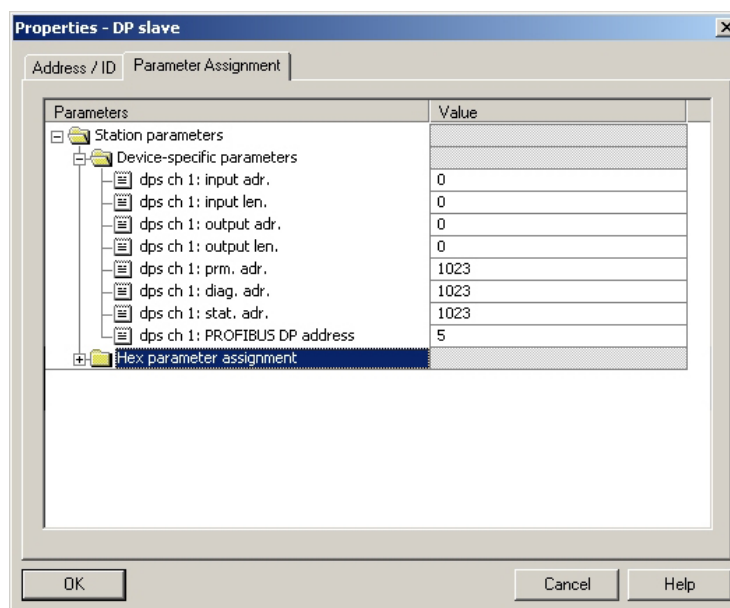

Input add., length

Address, from where on the data coming via PROFIBUS have to be stored in the CPU with the according "length".

When you enter a length of 0, the input areas do not occupy memory space in the CPU. The length is entered at the master in form of Byte groups for the PROFIBUS output section.

Output add., length

Address, where the data that has to be send via PROFIBUS is starting. Here too, you define the data width with *len*.

When you enter a length of 0, the input areas do not occupy memory space in the CPU. The length is entered at the master in form of Byte groups for the PROFIBUS input section.

Prm. Add. (24Byte fix)

The parameter data is an excerpt of the parameter telegram. The parameter telegram is created at master engineering and sent to the slave when:

- the CC 03DP is in start-up.
- the connection between CC 03DP and master was interrupted, like e.g. disconnection of the bus connector.

A parameter telegram consists of PROFIBUS specific data (bus parameters) and user specific data, where the in-and output bytes at the CC 03DP are defined.

The user specific data (Byte 7 ... 31) are shown in the memory area of the CPU with a fixed length of 24Byte starting with the address selected in *prm*. This allows to proof the parameters, which your slave gets form the master.

Diag. Add.
(5Byte fix)

The wide range of diagnostics facilities of PROFIBUS DP allow fast error localization. The diagnostics messages are transferred via the bus and collected at the master.

The CC 03DP is sending diagnostics data either on master request or in error case. The diagnostics data contain:

- Norm diagnostics data (Byte 0 ... 5),
- Device related diagnostics data (Byte 6 ... 10)
- **User specific diagnostics data (Byte 11 ... 15)**

Via *diag* you define the start address of the 5Byte user specific diagnostics data in the CPU.

With targeted access to this area you may initialize and influence diagnosis.

**Note!**

More detailed information about structure and possibilities with diagnostics messages is under "Diagnostics functions".

Stat. Add.
(2Byte fix)

The current status of the PROFIBUS communication can be seen in a 2Byte status area, stored in the periphery address range of the PLC starting at the status address.

**Note!**

More detailed information about the structure of a status message is under "Status message internal to CPU".

**PROFIBUS DP
address**

Via this parameter you assign a PROFIBUS address to your PROFIBUS slave. Please regard that every PROFIBUS address may be assigned only once!

**Release areas in
the CPU**

When entering the length 0, the according data do not occupy space in the CPU.

You may also release memory areas in the CPU by entering the address range limit 1023 at the parameters *PRN*, *DIAG* and *STAT*.

Diagnostics functions

Overview

The wide range of diagnostics functions at PROFIBUS DP allow fast error localization. The diagnostics data is broadcasted via the bus and summarized at the DP master.

The CC 03DP is sending diagnostics data either on master request or in error case. For a part of the diagnostics data is stored in the periphery address area (Byte 11 ... 15) of the CC-CPU, you may initialize and influence diagnosis. The diagnostics data contain:

- Norm diagnostics data (Byte 0 ... 5),
- Device related diagnostics data (Byte 6 ... 15).

Structure

The diagnostics data have the following structure:

Norm diagnostics data

Byte 0	Station state 1
Byte 1	Station state 2
Byte 2	Station state 3
Byte 3	Master address
Byte 4	Ident no. (low)
Byte 5	Ident no. (high)

Device related diagnostics data

Byte 6	length and code device related diagnosis
Byte 7	device related diagnostics messages
Byte 8 ... Byte 10	reserved
Byte 11 ... Byte 15	User specific diagnostics data are shown in the CPU periphery address range and may be altered and send to the master.

Norm diagnostics data

More detailed information about the structure of the norm diagnostics data is available in the PROFIBUS Norm Papers. These papers are delivered by the PROFIBUS User Organization.

The slave norm diagnostics data have the following structure:

Byte	Bit 7 ... Bit 0
0	Bit 0: fixed at 0 Bit 1: Slave not ready for data transfer Bit 2: Configuration data is not congruent Bit 3: Slave has external diagnostics data Bit 4: Slave does not support requested function Bit 5: fixed at 0 Bit 6: Wrong parameterization Bit 7: fixed at 0
1	Bit 0: Slave needs new parameterization Bit 1: Statistic diagnosis Bit 2: fixed at 1 Bit 3: Response control active Bit 4: Freeze command received Bit 5: Sync command received Bit 6: reserved Bit 7: fixed at 0
2	Bit 6 ... 0: reserved Bit 7: Diagnostics data overflow
3	Master address after parameterization FFh: Slave without parameterization
4	Ident no. High Byte
5	Ident no. Low Byte

Device related diagnostics data

The device related diagnostics data give detailed information about the slave and the in-/output periphery. The length of the device related diagnostics data is fixed at 10Byte.

Byte	Bit 7 ... Bit 0
6	Bit 5 ... 0: Length device related diagnostics data 001010: Length 10Byte (fix) Bit 7 ... 6: Code for device related diagnosis 00: Code 00 (fix)
7	Bit 7 ... 0: Device related diagnostics messages 12h: Error: Parameter data length 13h: Error: Configuration data length 14h: Error: Configuration entry 15h: Error: VPC3 buffer calculation 16h: Error: missing configuration data 17h: Error: Compare DP parameterization with project 40h: User defined diagnosis is valid
8 ... 10	reserved
11 ... 15	User specific diagnostics data that are stored after the diagnostics status byte in the process image of the CPU. They may be overwritten and forwarded to the master.

Initialize diagnosis

In case of diagnosis the contents of Byte 11 ... 15 of the device related diagnostics data are transferred into the process image of the CPU with the status byte as prefix. The position of this 6Byte diagnostics block in the process image of the CC-CPU is defined at the CC 03DP parameter adjustment.

With a status change of 0 → 1 in the diagnostics status byte you initialize a diagnostics and the according diagnostics telegram is transferred to the master. **The state 0000 0011 is ignored!**

The diagnostics block in the CC-CPU has the following structure:

Byte	Bit 7 ... Bit 0
0	Diagnostics status byte: Bit 0: user specific diagnostics data 0: invalid diagnostics data 1: valid diagnostics data (initialize diagnosis) Bit 1: Delete diagnosis 0: Delete diagnosis invalid 1: Delete diagnosis valid Bit 7 ... 2: reserved
1 ... 5	Bit 7 ... 0: User specific diagnostics data equal to Byte 11 ... 15 of the device related diagnosis

Status message internal to CC-CPU

The current status of the PROFIBUS communication is shown in the status messages that are included in the periphery address range of the CC-CPU. The status messages consist of 2Byte and have the following structure:

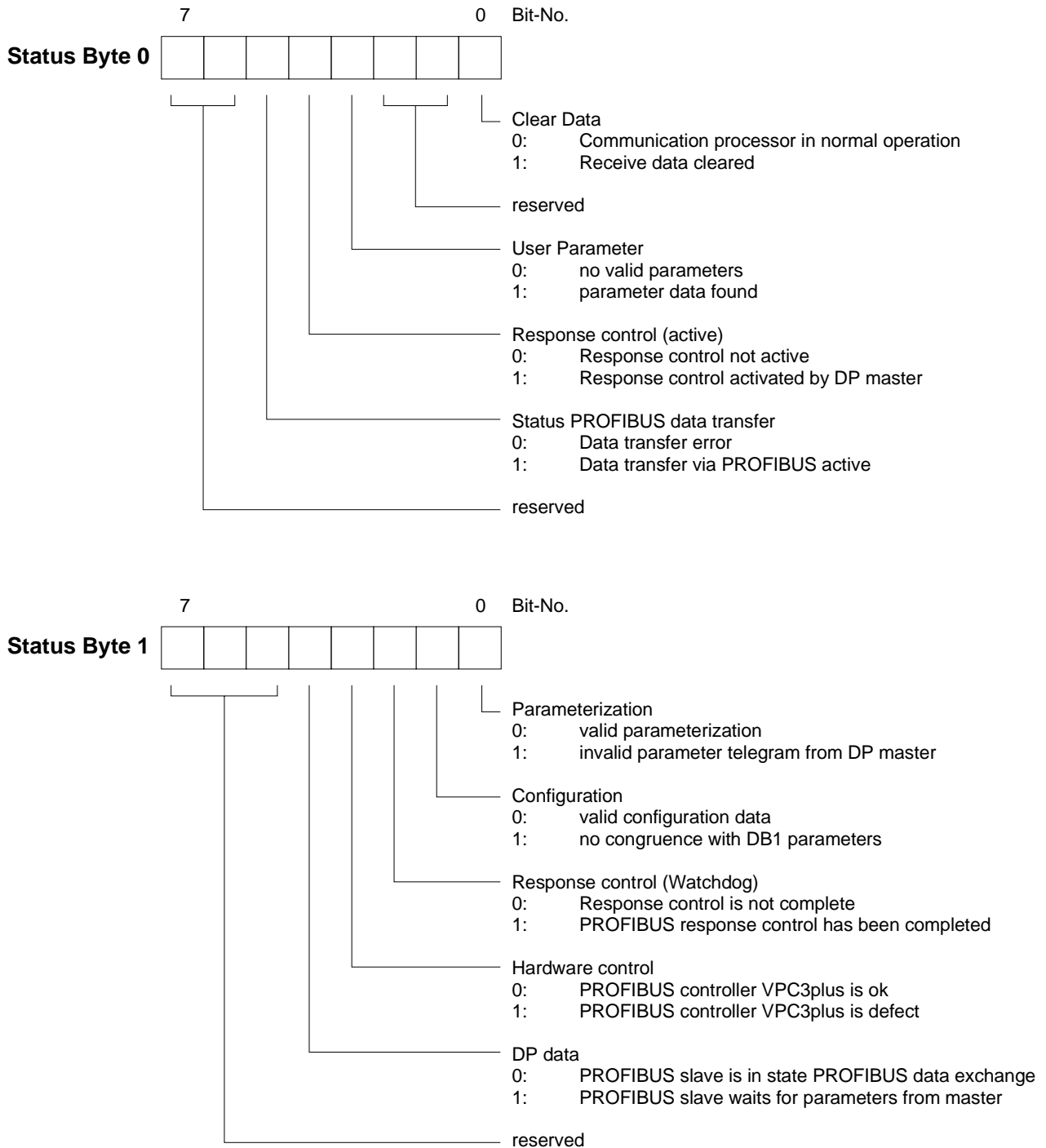

Parameter

Clear Data	In error case, the send and receive buffers are deleted.
reserved	These Bits are reserved for future expansions.
User Parameter	Shows the validity of the parameter data. The parameter data are entered at the master parameterization tool.
Response control (active)	Shows the activation status of the response control in the next higher PROFIBUS master. When the response control time is exceeded, the slave terminated the communication.
Status PROFIBUS data transfer	Status monitor of the communication with the higher master. With invalid configuration or invalid parameters, the communication is terminated and the error is shown via this Bit.
Parameterization	Shows the status of the parameter data. The length of the parameter data and the number of parameter bytes is compared. Only if these are identical and not more than 31Byte parameter data are transferred, the parameterization is correct.
Configuration	Status monitor of the configuration data that are send by the PROFIBUS master. The configuration is created in the master project engineering tool.
Response control (Watchdog)	The status of the response control in the PROFIBUS master is monitored. When the response control is active and the response time in the slave is exceeded, an error is shown here.
Hardware control	If a Bit is set here, this shows a failure in the PROFIBUS controller of the CC 03DP. Please contact the VIPA hotline.
DP data	This Bit is set at a transfer error.

PROFIBUS installation guidelines

PROFIBUS in general

- A PROFIBUS DP network may only be built up in linear structure.
- PROFIBUS DP consists of minimum one segment with at least one master and one slave.
- A master has always been deployed together with a CPU.
- PROFIBUS supports max. 126 participants.
- Per segment a max. of 32 participants is permitted.
- The max. segment length depends on the baud rate:

9.6 ... 187.5kBaud	→	1000m
500kBaud	→	400m
1.5MBaud	→	200m
3 ... 12MBaud	→	100m
- Max. 10 segments may be built up. The segments are connected via repeaters. Every repeater counts for one participant.
- All participants are communicating with the same baudrate. The slaves adjust themselves automatically on the baudrate.
- The bus has to be terminated at both ends.
- Master and slaves are free combinable.

Assembly and inclusion in PROFIBUS

- Assemble your PROFIBUS system with the concerning modules.
- Configure your CC 03DP at the slave and the master.
- Transfer your projects into the according CPUs.
- Connect the PROFIBUS cable to the coupler and turn on the power supply.

Transfer medium

As transfer medium PROFIBUS uses an isolated twisted-pair cable based upon the RS485 interface.

The RS485 interface is working with voltage differences. Though it is less irritable from influences than a voltage or a current interface. You are able to configure the network as well linear as in a tree structure. Your VIPA CC 03DP includes a 9pin slot where you connect the PROFIBUS coupler into the PROFIBUS network as a slave.

Max. 32 participants per segment are permitted. The segments are connected via repeaters. The maximum segment length depends on the transfer rate.

PROFIBUS DP uses a transfer rate between 9.6kBaud and 12MBaud, the slaves are following automatically. All participants are communicating with the same baudrate.

The bus structure under RS485 allows an easy connection res. disconnection of stations as well as starting the system step by step. Later expansions don't have any influence on stations that are already integrated. The system realizes automatically if one partner had a fail down or is new in the network.

Bus connection

The following picture illustrates the terminating resistors of the respective start and end station.

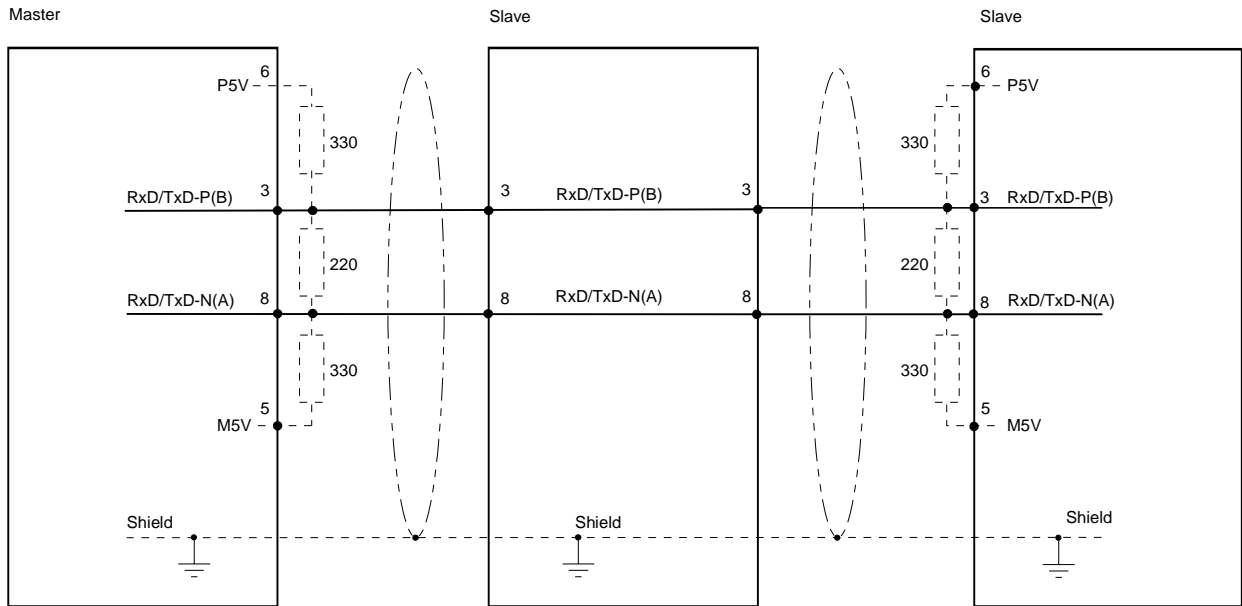

Note!

The PROFIBUS line has to be terminated with its ripple resistor. Please make sure to terminate the last participants on the bus at both ends by activating the terminating resistor.

"EasyConn" bus connector



In systems with more than two stations all partners are wired in parallel. For that purpose, the bus cable must be feed-through uninterrupted.

Via the order number VIPA 972-0DP10 you may order the bus connector "EasyConn". This is a bus connector with switchable terminating resistor and integrated bus diagnostics.

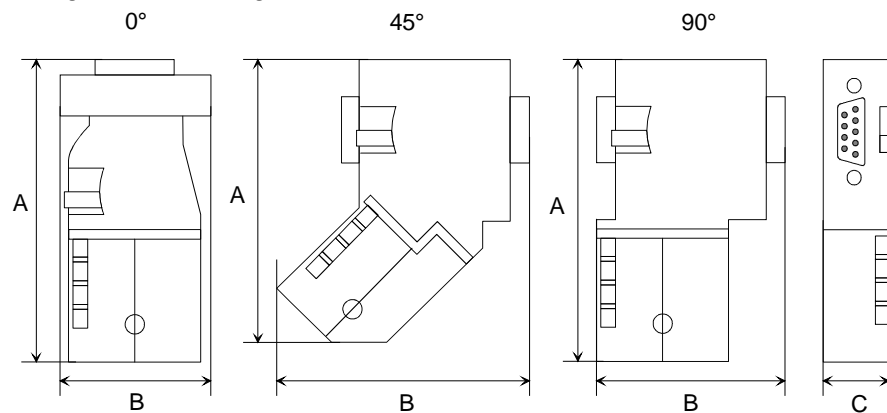

	0°	45°	90°
A	64	61	66
B	34	53	40
C	15.8	15.8	15.8

all in mm



Note!

To connect this EasyConn plug, please use the standard PROFIBUS cable type A (EN50170). Starting with release 5 also highly flexible bus cable may be used: Lapp Kabel order no.: 2170222, 2170822, 2170322.

Under the order no. 905-6AA00 VIPA offers the "EasyStrip" de-isolating tool, which makes the connection of the EasyConn much easier.

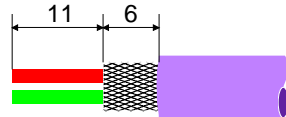

Dimensions in mm

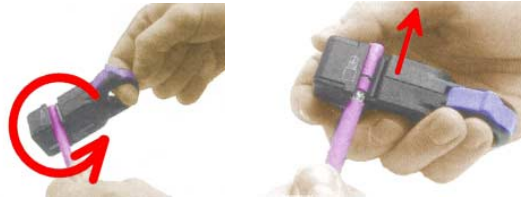

Termination with "EasyConn"

The "EasyConn" bus connector is provided with a switch that is used to activate a terminating resistor.

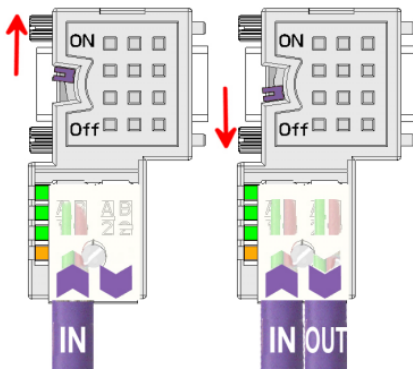

Attention!

The terminating resistor is only effective, if the connector is installed at a slave and the slave is connected to a power supply.

Note!

A complete description of installation and deployment of the terminating resistors is delivered with the connector.

Assembly

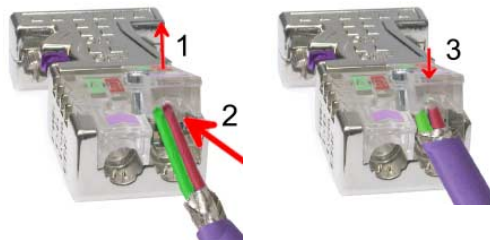

- Loosen the screw.
- Lift contact-cover.
- Insert both wires into the ducts provided (watch for the correct line color as below!)
- Please take care not to cause a short circuit between screen and data lines!
- Close the contact cover.
- Tighten screw (max. tightening torque 4Nm).

Please note:

the **green** line must be connected to **A**, the **red** line to **B**!

Examples for PROFIBUS networks

One CPU and several master lines

The CPU should have a short cycle time to guarantee the actuality of the data in slave no. 5 (right side). This structure is only convenient when there are only slaves coupled to the slow line (left), which data actuality is not important. No alarm throwing modules should be placed here.

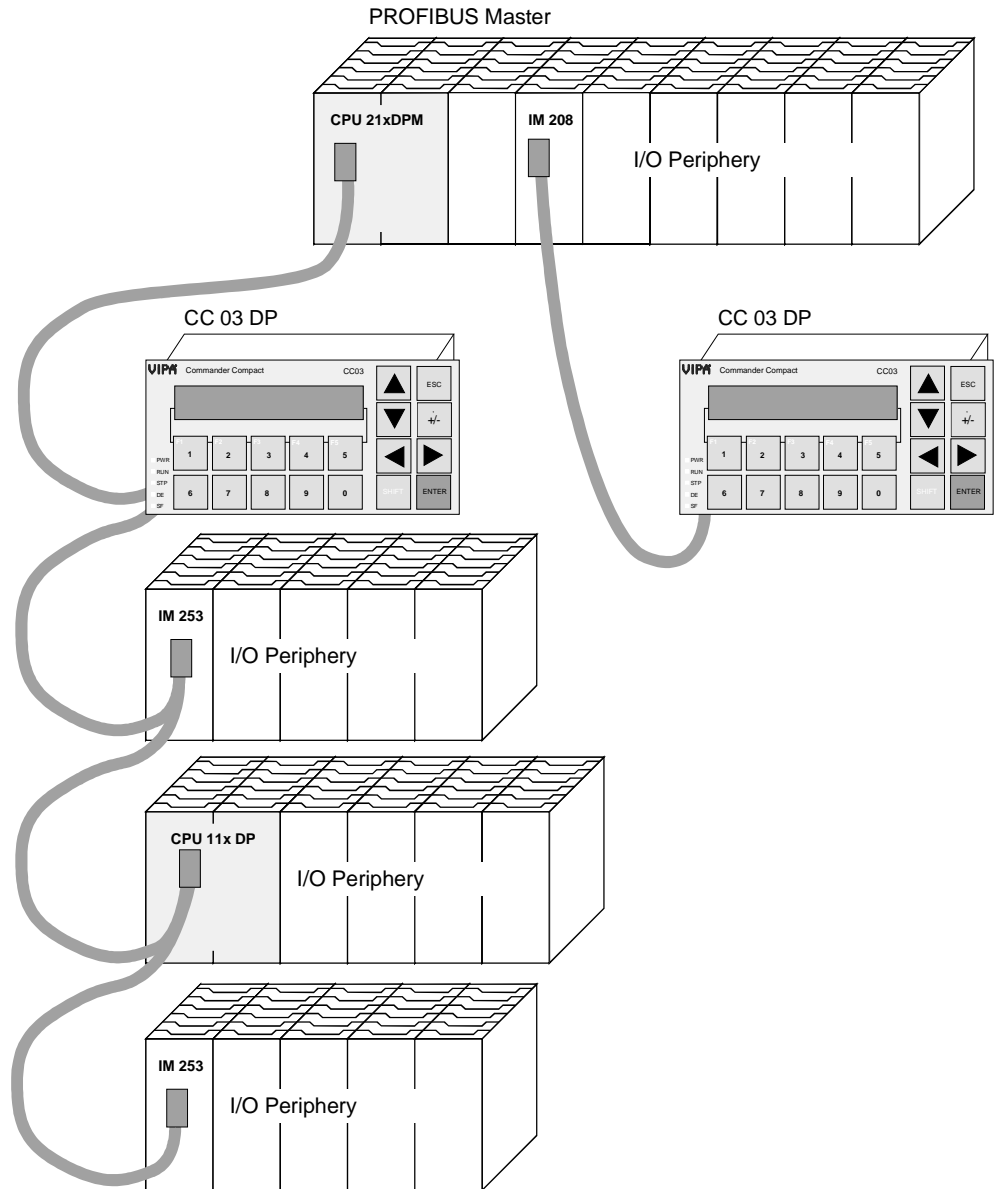

Multi master system

Several master connections at one bus together with several slaves:

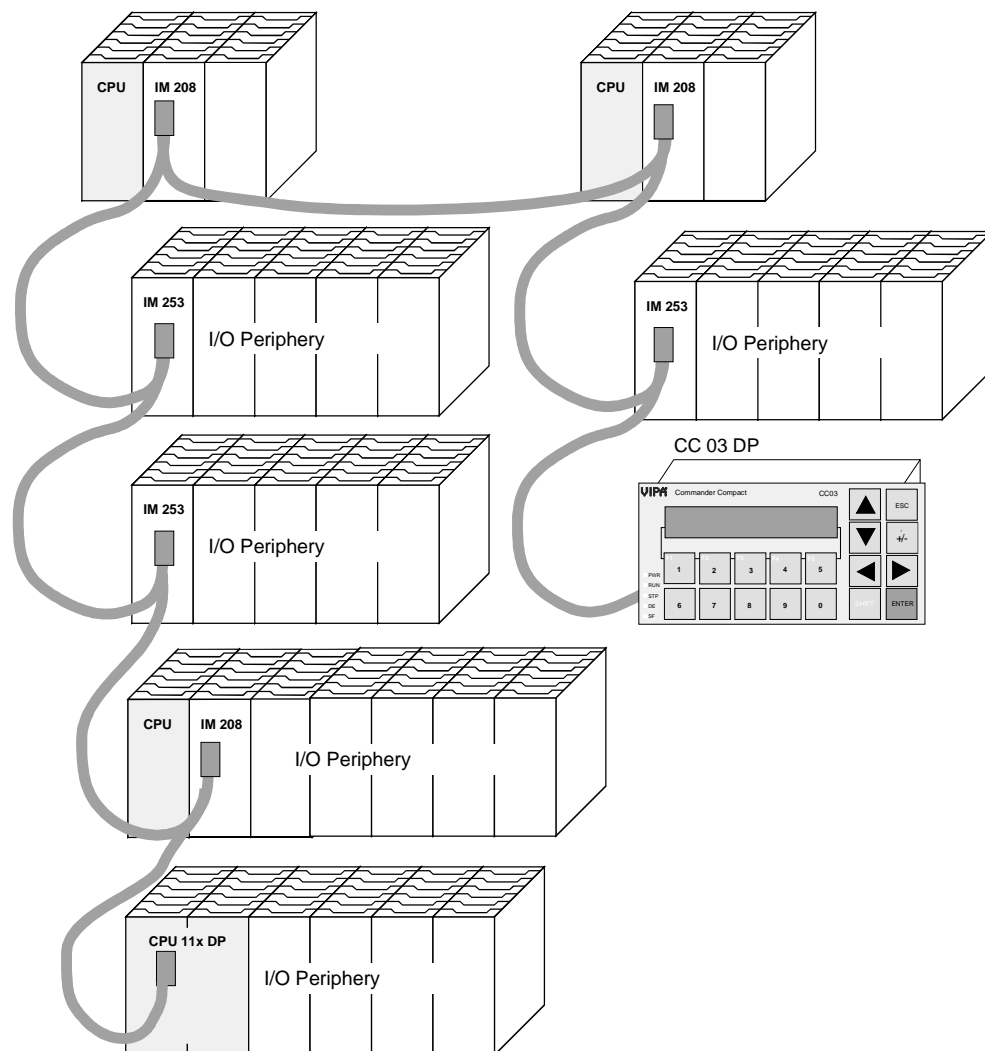

Commissioning

Overview

- Build up your components.
- Project the CC 03DP as "CPU 11xDP" at the master.
- Configure the CC 03DP with possible in-output periphery as "CPU 11x" at the slave section.
- Connect the CC 03DP with the PROFIBUS.
- Turn on the power supply.
- Transfer your project into the respective CPUs (CC-CPU and Master-CPU).

Assembly

Install your CC 03DP and connect the cables like shown in the chapter "Deployment CC 03 - Operator panel". Link-up the CC 03DP to your DP master via PROFIBUS.



Note!

To avoid transfer irritations from reflections, the bus cable has always to be terminated with its ripple resistor at the cable ends!

Configuration at the master

Project your CC 03DP as "CPU 11xDP" in your master system. To engineer you have to include the GSD VIPA04Dx.GSD. Transfer your project in the master PLC.

Configuration CC 03DP and I/O periphery

Project your CC 03DP at the slave. You need the GSD VIPA_11x.GSD. The in-/output periphery is automatically overlaid in the CPU address range. The address allocation may be altered in the hardware configurator from Siemens at any time. Transfer your project via MPI in the CC 03DP.

Power supply

The CC 03DP has an integrated mains power supply. It has to be provided with DC 24V. Via the supply voltage not only the CC 03DP and the bus coupler is provided but also the connected modules via the backplane bus. Please regard that the internal power supply may provide the backplane bus with max. 800mA. PROFIBUS and backplane bus are isolated.

Transfer project

The transfer of the hardware configuration into the CC 03DP takes place via MPI.

- Connect your PG res. the PC via MPI with the CPU.
If your programming device has no MPI slot, you may use the VIPA Green Cable to establish a serial point-to-point connection.
The Green Cable has the order no. VIPA 950-0KB00 and only be used with the VIPA components.
- Configure the MP interface of your PC.
- With **PLC > Load to module** in your projecting tool, you transfer your project into the CC 03.
- For the additional security copy of your project on MMC, you plug-in a MMC and transfer the user application to the MMC via **PLC > Copy RAM to ROM**.
During write operation the MC-LED on the PLC blinks. Due to the system, the successful writing is signaled too soon. The write command has only been completed, when the LED extinguishes.

**Attention!**

Please regard the hints for deploying the Green Cable and the MP²I jack at chapter "Deployment CC 03 - CPU part".

Initialization phase

After the start-up, the CC 03DP executes a self-test. It proofs its internal functions, the communication via backplane bus and to PROFIBUS.

At successful test the parameters are read from the PLC and the PROFIBUS slave parameters are proofed.

After successful boot procedure the PROFIBUS part of the CC 03 PD switches to "READY".

Communication problems at the backplane bus cause the CC-CPU to go in STOP and start again after app. 2 seconds. When the test has been completed positive, the RD-LED blinks.

At starting communication, the DE-LED is on.

Chapter 5 Functions operator panel

Overview

This chapter informs you about the functionalities of the operator panel. Especially referred to is to the functions that are part of the standard project.

The text describes how you access screens, use operating keys, react to messages, alter values and use the password protection.

Content

Topic	Page
Chapter 5 Functions operator panel	5-1
Screens	5-2
Standard project with standard functions	5-4
Process depending operation	5-5
Messages	5-12
Timer and Counter	5-15
Operating mode.....	5-16
StatVAR and ForceVAR	5-17
Password protection.....	5-19

Screens

Overview

To monitor the process execution, the operator panel uses "Screens". A screen consists of a matrix of 2x20 characters that corresponds to the size of the display.

You may program this screens in the OP-Manager.

Screens collect logical matching process values and give you an overview over a process or an installation.

The screens allow you to enter process values and thus control the process.

To structure your process, you may develop up to 40 screens with up to 20 entries where you can branch if needed.

Screen components



Screens consist of entries. Every screen can contain several entries. Always one entry is shown per display page.

If existing, a not ready programmed row is monitored in the display as empty. A screen may include the following elements:

- Message and description texts like e.g. explanations for the user. The texts may also contain information about the soft key functions.
- Fields for in- and output of date, time, effective value and set point.
- Definitions of the soft keys that are programmed to different function calls depending on the screen.

Alter screen

You may enter values in a screen. Use the following approach:

- Choose the screen you want to alter.
→ The cursor jumps to the first input field.
- Move the cursor with  res.  to the according field and enter the wanted value.
- Confirm your entry with .
- Repeat this for all values that you want to alter.
- Finish the change e.g. with ESCAPE.

Screen contents list

During the operation, you may access screens via programmed soft keys or via integrated special functions.

At the project engineering in the OP-Manager, the main screens are collected in a screen contents list under "Screens" and listed with name and screen number.

Automatical update of values

During the project engineering in the OP-Manager you may set a poll rate for every variable that defines the interval for the variable update.

Please regard that the lowest poll rate is decisive for the complete screen entry.

To optimize your project engineering, you should:

- program the poll rate as high as possible (min. 1 second).
- program low poll rates only for critical variables.
- refer to only one CPU per entry. The OP 03 allows a max. of 2.

In- and output fields

Output fields display effective values of the control in numeric or symbolic format. Input fields enter set points in numeric or symbolic format. In input fields you can see the blinking cursor.

For symbolic in- and output fields, you may configure up to 256 texts where you can choose from via a selection field. The selected text is taken over.

For numeric value entries, configured number formats res. limit values are valid, regarding the number of digits in front and behind the comma.

Screen level and message level

The operator panels have two different operating levels that you may use.

Screen level:



The screen level serves the selection, operation and execution of functions.

You reach the screen level via . The first screen is the so-called start screen. From here, you can branch, depending on the project engineering, into other screens. The screens display recent process values, you may enter values and initialize functions via the soft keys.

Jump back to the message level with .

At messages, the operator panel branches into a temporary message level.

As soon as you acknowledge every message with , the panel jumps back to the previous screen.

If several messages are waiting for acknowledgement, you may switch between them with  res. .

Message level:

The message level displays recent messages like incoming operating and system messages.

After start-up, the operator panel switches to the message level.

Standard project with standard functions

Standard project after RESET

The project engineering tool OP-Manager allows you to load a "standard project". This project contains all functions available via standard screens. This project remains active also after a RESET of the operator panel.

As long as no project engineering is loaded res. after a RESET, the following standard project is activated with English dialogs.

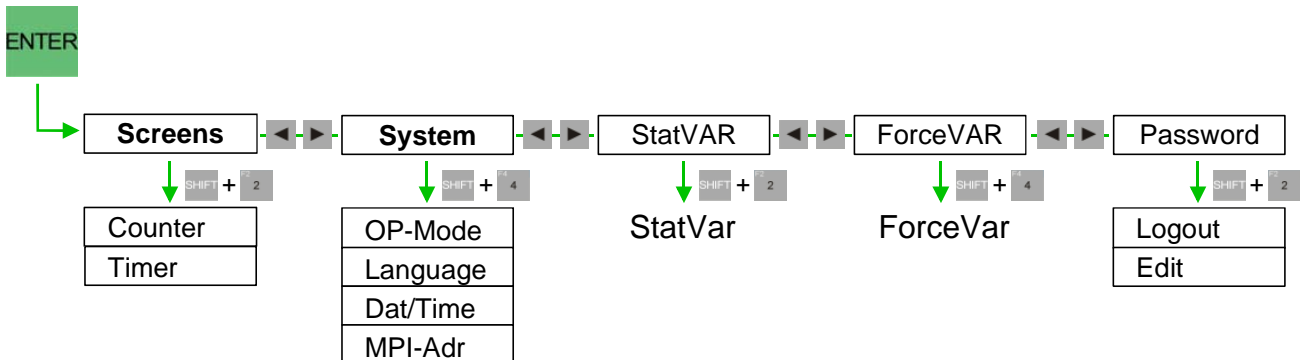

Functions in standard screens

The call of screens of the standard project happens via soft key. Depending on the project engineering, you have to use the **SHIFT** key additional to the soft key.

The following standard screens are part of the standard project:

- **Screens**

Via "Screens" you can enter a screen contents list that shows all screens that have been marked at the project engineering with the attribute "Screen to Directory" (Contents list). Without further programming, the contents list displays the two standard screens "Counter" and "Timer".

- **System**

"System" allows you the access to the system settings. You may choose, for example, the operating mode, the language or set date and time.

- **StatVAR**

This function starts the PG function STATUS VAR that allows you to display operands of the destination CPU.

- **ForceVAR**

This function starts the PG function STEUERN VAR that allows you to display and alter operands of the destination CPU.

- **Password**

Here you may set up to 20 passwords for up to 9 different password level.

Process depending operation

Screen hierarchy

The project engineering allows you to adjust the screen hierarchy to the installation specific needs by adding, coupling or removing screens.

During the project engineering you define the start screen, structure, sequence of the coupling, entry in the contents list and the return destinations.

The branch into several screens happens via soft keys and programmed return destinations.

Evaluation of the screen number

The screen number area is in the CPU. Here the operator panel stores the number of the recent called screen.

As soon as the CPU writes a number into this are, the according screen is displayed at the operator panel.

If you want to use the screen number area, you have to configure this in the OP-Manager. Create the screen number area in the project object group via the register "Area Pointer".

Choose the register "Area Pointer" and create a new object with the type

"Screen number" via  and assign a DB or a bit memory area.

The screen area consists of a double word and has the following structure:

Double word	Byte 0		Byte 1
	Bit 7	Bit 6 ... 0	Bit 7 ... 0
1. DW (Display content)	Bit 7 = 1 (ID for special screen)	Screen number	Entry number
2. DW (CPU entry)	Bit 7 = 1 (ID for special screen)	Screen number	Entry number

The first data word is filled by the operator panel with information about the monitored display content.

As soon as the CPU writes a screen and entry number into the second data word, the according screen is displayed at the operator panel with the concerning entry.

The entry FFFFh in the 1. or 2.DW marks the message level.

As soon as a 0 is in the 2.DW, your operator panel is ready for employment.

Special screens When the highest valued bit is set in the DW of the screen number area ("1"), a special screen is displayed.
 When the highest valued bit in the DW of the screen number area is deleted ("0"), a user specific screen is displayed.

Screen number	Special screen
0	Screen contents list
25 (19h)	Status Variable
26 (1Ah)	Control Variable
30 (1Eh)	Language selection
31 (1Fh)	Change operating modes
35 (23h)	Set Date/Time
36 (24h)	MPI address/Baud rate
55 (37h)	Password Login
56 (38h)	Password Edit

Example for screen selection via CPU

An example shows you the screen selection of screen number 2.

	Screen No.	Entry No.
1. DW	x	x
2. DW	x	x

The operator panel shows a not specified screen.

	Screen No.	Entry No.
1. DW	x	x
2. DW	0	x

To recognize and overtake an alteration, your user application must write a "0" to the 2. DW of the screen number area.

	Screen No.	Entry No.
1. DW	x	x
2. DW	2	x

At the earliest after one poll cycle (1 second) your user application may transfer the value 2.

	Screen No.	Entry No.
1. DW	2	x
2. DW	2	x

The operator panel recognizes the change from 0 to 2 and displays the according screen. For control purposes, the screen number is written to the 1. DW.

Keyboard input

At the front side there is a foil keyboard with 18 short click keys. 8 keys serve the navigation and 10 are numerical keys where 5 can be programmed as function keys.

When you push a function key, a bit is set into a bit memory byte of your CPU. By requesting the bit memory byte in your PLC application, you may react to an entry.

The numeric and cursor keys are provided with a repeat function. If you hold the key down, the key is after a short delay time repeated as long as you push the according key.



Note!

If you push several keys fast consecutively, some entries may get lost. Not received keys are signalized via an acoustic signal.



Numerical keys

The numeric keys enter numeric digits (0...9).



Soft keys (F1 to F5)

The numeric keys 1 ... 5 may be configured as soft keys, i.e. this keys can be programmed with screen depending functions. You enable the soft key functions by pushing the SHIFT key and simultaneously one of the keys 1 to 5.





SHIFT key

Switches to the second function of double programmed keys.  is pushed simultaneously with another key.



Math sign key

 allows you to change the math sign res.  +  to set a comma.



ENTER key (Return)

This key confirms and finishes an entry. ENTER also switches from the message to the screen level.

ESC



ESCAPE key



This key allows you to:





- clear field entries as long as they have not been confirmed with .
- branch back from the start screen to the message level or within a screen to a defined jump back destination.
- interrupt the leafing of messages and display of the recent message.
- leave a system message.

Navigation



For the navigation, the following keys are available:



 res.  navigation to previous res. next screen

 res.  navigation to previous res. next screen



Push additional  to navigate horizontal within a screen with  res.  and to choose a character from the character set that can not be entered via keyboard with  res.  e.g. at Hex input.

Enter the SETUP

Push simultaneously the key combination  +  +  before turning on and during the boot time to reach the SETUP where you can alter basic functions.

The navigation happens with  res. , The selection with .  leaves the SETUP again.

Set display contrast

The display contrast is set in the SETUP using  +  res. .

Functions of the SETUP

The SETUP provides the following functions:





- **Setup default prog**

This function overwrites the recent project engineering with the standard project.

- **Download from PC**

This function enables the operator panel to receive engineering data from the OP-Manager via MPI.

In delivery state your operator panel has the MPI address 1.

To control the MPI address you may also leave the SETUP with 2x  and display via  SYSTEM  >>  MPI-ADR  the MPI address and baud rate. Alteration of this values happens in the OP-Manager via the project engineering.

To return to the SETUP, you have to turn off the operator panel and turn it on again pushing the shown keys.

Choose **Download from PC** and push .

After the data transfer has finished, the data is proofed and stored in the memory. When executed with OK, your operator panel starts again with the new project engineering.

- **Display error log**



All error codes stored in the operator panel are displayed.





Note!

Please regard that some functions like e.g. "Download from PC" are already included in the standard project. By including it into your project, you may use them as soft key functions without setup call.

Soft keys

The keys  ...  can be programmed as soft keys in your project engineering tool and be configured with screen depending functions.





The access to the soft keys can be programmed for usage with or without additional  key. This can be set via  in the OP-Manager.

System keyboard image

You can reserve a data area in your CPU for the system keyboard. Every key uses one Bit. By according evaluation your user application may react to key pushes.

If you want to create a data area for the system keyboard, you have to configure it in the OP-Manager. Choose for this the register "Area Pointer" in the project object group.

Create a new object of the type "System Key Assignment" with  and assign a DB or bit memory area. The keyboard data area consists of a double word and has the following structure:



	Byte 0								Byte 1							
Bit	7	6	5	4	3	2	1	0	7	6	5	4	3	2	1	0
1. DW																
2. DW	Sum bit						9	8	7	6	5	4	3	2	1	0

The sum bit 7 in the 2. DW serves as control bit. At every transfer of the keyboard image from the operator panel to the CPU it is set to the value "1" and should set back from your user application after evaluation.



Value entries



Input fields allow you to enter values that are transferred to the control.

Approach

1. Branch into the wanted screen and there to the according screen entry.
2. Use the cursor keys to select the wanted input field.
3. Enter the wanted value. Depending on the project engineering of the field you may enter values as:
 - numeric values
 - alphanumeric values
 - symbolic values
4. Confirm your entry with .
 Clear a wrong value with .
 The original value it then set back into this field. Repeat the entry with the correct value.
5. Leave the screen entry with .

Numeric values

Input fields that allow the entry of numeric values are filled via the number field of the keyboard digit per digit. An already started input can only be confirmed with  or aborted with .

To enter a decimal value, use  + .

An already entered value is automatically deleted.

The input is linked to the right side. Entered digits are added right. Input fields in bit pattern format are linked to the left. Existing values are overwritten from the left.

Move here the cursor with  and  res. .



Number formats and Limit value evaluation

The OP-Manager allows you to set limit values and number formats for numeric input fields. These fields execute a limit value evaluation. The values you enter are only accepted if valid and within the defined range. If you enter a value exceeding the range, a system message appears. After abort, the previous value is displayed.

If the format of a numeric field has been set to a certain number of digits after the comma, empty places are filled with a 0, too many digits are ignored after acknowledgement.





Alphanumeric values

Alphanumeric values contain digits as well as characters. Enter the digits like shown above.

If you want to enter a character at the cursor position, you have to activate the alphanumeric character set. Push  and choose the according character via  res. .

Symbolic values

Symbolic values are texts res. value that can be chosen from a selection list.

Push  and choose the according entry via  res. . Confirm with .

Messages

Overview

Events and states of the control process are shown on the operator panel as messages.

Normally, a message consists of a static text and if wanted additionally variables. Messages can be:

- configurable operating messages that are initialized by the CPU,
- (error-) system messages that are initialized by the operator panel.

Operating messages

Operating messages contain process related information in form of static text and variable fields like e.g. messages about states or processes of an installation. Here you may display e.g. recent control effective values in numeric or symbolic format. You may configure operating messages as status messages as well as operating hints.

Configure operating message

The output of a message happens event triggered. As soon as an event takes place in the specified CPU, the according message is shown, sorted after priority. Acknowledge every message with . Please regard that you first have to configure the event in your project object group in the register "Area Pointer", if you want an event to cause a message.

Select the register "Area Pointer" and create a new object of the type "Event Messages" via . Assign a DB or bit memory area. For every bit in the operating message area you may configure one operating message. The operating message area can be divided in up to 4 address ranges. The address ranges need not to be in sequence. The assignment of message number and bit number happens automatically like shown in the picture:

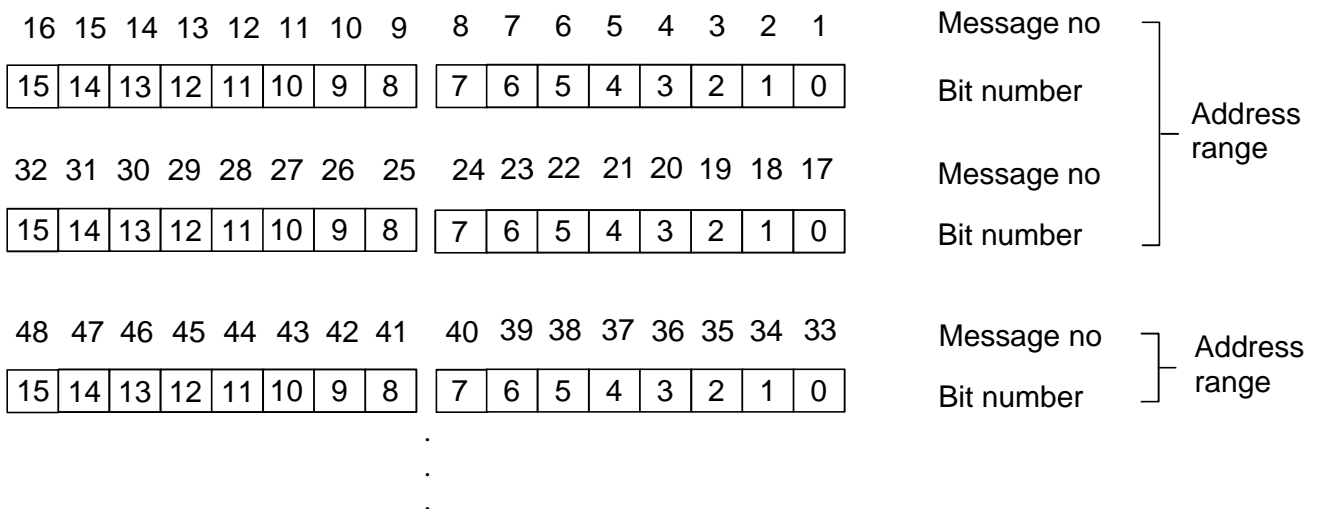

Standby message When your operator panel is on message level and there is no message waiting, "Standby" is displayed as operating message. The standby message is stored in the firmware and contains per default release version and device type. You may change the content of the standby message via the message number 0 in the OP-Manager. You may display altered text, date and time but no variables.

System messages System messages display internal operating states of the operator panel. They may monitor e.g. wrong handling or communication problems. This message type has the highest display priority. If a failure occurs, the recently displayed operating message fades and the system message is shown.

"Heavy" system message A "heavy" system message requires a reboot of the operator panel.

Normal system message All other errors cause normal system messages. The display of a normal system message can be aborted at any time with **ESC**. You return to the screen before.
 The OP-Manager allows you to deactivate the output of system messages and preset the display duration.
 After timeout the operator panel jumps automatically back to the previous screen.

Display priority System messages always have the highest display priority. Operating messages are displayed after message priority. You may configure the priority for the operating messages during the project engineering, depending on the importance from 1 (low) to 4 (high). If several messages with the same display and message priority occur, the latest message is always shown first.

Example



Reception sequence	Display sequence
1. Operating message A (Priority 2)	1. System message A
2. Operating message B (Priority 3)	2. Operating message D (Priority 4)
3. Operating message C (Priority 2)	3. Operating message B (Priority 3)
4. System message A	4. Operating message C (new with Priority 2)
5. Operating message D (Priority 4)	5. Operating message A (older with Priority 2)

Message buffer

The message buffer contains the last 50 messages in sequence of their reception.

If the message buffer is filled, the oldest message is deleted. If there are more than 50 messages (message rush), only the recent 50 are shown in the message buffer. It is not possible to monitor more than 50 messages.

Scrolling

If no system message is waiting, you may scroll up down with  res.  between waiting operating messages, which are displayed in the sequence of their reception and sorted after priority.



Shows the next older (lower priority) message. After the oldest message of one priority group, the newest message of the next lower priority is displayed. "↓↓↓" marks the end of the messages.



Shows the previous (higher priority) message. After the newest message of a priority group the oldest of the next higher priority group is displayed. "↑↑↑" marks the end of the messages.



Jumps back to the recently waiting message. This automatically happens also after 1 minute delay time.

Languages

Via the option "Language Assignment", the OP-Manager allows you to select up to 3 of 8 languages for screens and operating messages. Choose the according language in the OP-Manager and configure the according screens and messages. Now you may adjust screens and message text in the available up to 3 languages.

The texts for the system messages in 8 languages are fix integrated in the operator panel. The text output depends on the language that is set at the operator panel.

You may choose one of the 3 configured languages at any time during operation. To switch the language, you may choose **System** > *Language* enter your password (Standard: 100) and change the language. The selected language must be programmed before.

After the language selection, the operator panel restarts and all language related texts are displayed in the selected language.

Timer and Counter

Overview

Your operator panel allows you access to timer and counter of the CPU. You may only set time res. counter values. Start res. stop of timer and counter are not possible.

Examples for that you may see in the standard screens. The access to timer and counter happens via the standard screens *"Timer"* and *"Counter"*.

Effective value and set point

You may display the recent effective value for every programmed and in the CPU activated timer function. Examples are to find in the standard project under screens. Choose the standard screen *"Screens"* → *"Timer"* in the standard project.

The display shows:

```
Set point      0.00           Timer 1
Effective value 0.00
```

The 1. row shows the recent timer value. The 2. row allows you to enter a set point.

ESC leaves the screen.

Time base





The common time base for every timer is configurable (10ms, 100ms, 1s or 10s). Your operating device recognizes the chosen time base and nominates the display value to seconds.

Date and time

The operator panel process date and time internally.

Please regard that the OP 03 has no integrated clock. You have to enter date and time after every reboot.

Alter date and time

The standard project allows you via **System** > *Dat/Time* to alter date and time. Switch between date and time with  res. . Within an input field you may navigate with  +  res. .

Confirm the entered value with .

Operating mode

Overview Your operator panel is provided with integrated system functions that allow you to set the operating mode of the panel.
The following operating modes are available:

- Online
- Offline
- Transfer

Online Your operator panel always starts in the operating mode "Online". The operating mode "Online" means a logical connection between operator panel and CPU res. it is tried to establish a connection.

Offline "Offline", your operator panel works separately from the CPU. No connection establishment is tried. Thus allows you to suppress CPU error messages for test purposes.

Transfer The operating mode "Transfer" initializes the operator panel to receive a project engineering via MPI. As communication parameter, the parameters defined at "MPI-Adr" in your operator panel are used.
When your operator panel is in the operating mode "Transfer", you may connect your PC via MPI and transfer your project online from the OP-Manager. You may interrupt the transfer at any time via .
For the connection, you may use either an MPI adapter or the "Green Cable" from VIPA for a serial point-to-point connection. When using the Green Cable you have to set the transfer rate in the OP-Manager to 38400 Baud.



Note!

Please regard that the online project engineering is only available with a licensed version of the OP-Manager!

Navigation In the standard project, the operating mode setting is under **System** > *OPMode*.

Change the operating mode with  +  res. . This function requires a password. The password of the standard project is 100.

StatVAR and ForceVAR

Overview

The functions StatVAR and ForceVAR allow you to monitor res. alter operand values of a connected CPU. So you may alter control operands directly during online operation.

- StatVAR monitors the operands of the CPU
- ForceVAR monitors the operands of the CPU and allows you to alter them. You may not use ForceVAR to fix values but only alter them during runtime.



Note!

The functions StatVAR and ForceVAR are to find in the standard project.

Start

In the standard project these functions are password protected. The password is 100. Starting from the message level, you see both functions like shown in the menu structure:

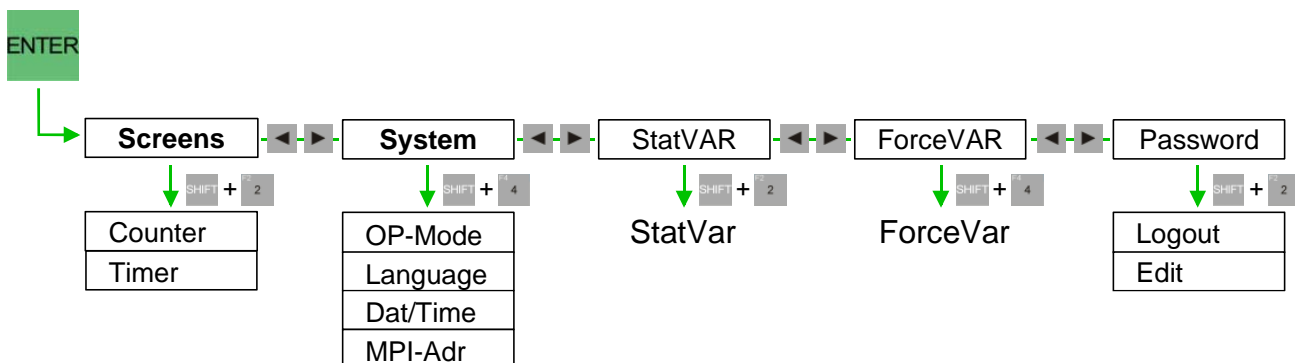



MPI address



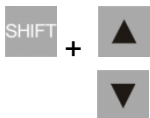

After the call of StatVAR res. ForceVAR you need the MPI address of the destination CPU. Default address is address 2.



At the OP 03, this 2 functions give you the opportunity to connect an additional CPU to complete the already configure ones.

Key functions



After entering the MPI address, you reach the operand field with the cursor key .

Push  and choose with  or  the data type that you want to display.  sets automatically the according data format in the format field.

The key  brings you to the numeric input field. Use the numeric key block to type the number of the operand to monitor res. at ForceVAR the operand to monitor and alter and confirm with .

Every operand value that shall be monitored or altered has to be defined in a "Screen". You may create up to 10 screens.

Within a screen res. a value field you navigate the blinking cursor with the arrow keys.

Confirm your entries for every field with . The values of the displayed operands are shown in the preset format in the value field.



The key combination  +  deletes single rows.



After you've altered the operand list, the values in the control must be updated. This happens immediately after the verification of a single value.

When you press the enter key again after the last confirm of your entries, the new values are transferred to the control.



Note!

During the status update, a blinking * is shown in the right upper corner of the display. If the star is not blinking, no logical connection to the control is established.

During the update process, no entries are permissible.

You may interrupt the update at any time via .

Password protection

Overview

To avoid unauthorized access, the operator panel provides an integrated password protection. This includes the definition of passwords for up to 8 password level. The assignment of the password levels happens in the OP-Manager. With raising importance of the functions you may set a password level from 0 to 9 at the project engineering of soft keys.

Enter Level 0 to deactivate the password request.

A password of the level 9 gives you access to all other password levels. This "Supervisor-Password" is set in the project engineering.

The passwords for the levels 1 to 8 are exclusively set in the operator panel. The screen "Password" is required in your project (see standard project).

Set Supervisor-Password

The Supervisor-Password gives you access to all functions of your operator panel. The Supervisor-Password is transferred to the operator panel

together with the project. To enter a Supervisor-Password click on  in your project. The following dialog window appears:

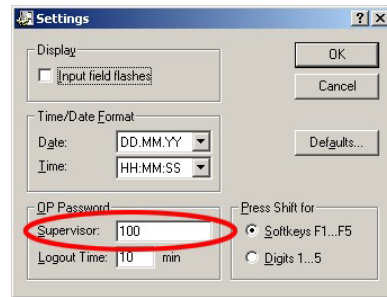

Set a password under "Supervisor" and define via "Logout Time" how long after the login the password will be valid.

Set password level

You may set a password level for every soft key definition like shown in the picture.

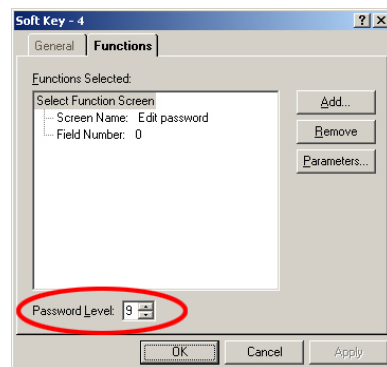

Please regard that the password levels for integrated standard screens of the operator panel are fix like e.g.:

Level 9: Password Edit, OP-Mode

Level 8: ForceVAR

Level 0: StatVAR, Password>Logout

More detailed information see following page.

Set password at the operator panel for level 1 to 8

Precondition

You've included the screen "Password" into your project and you know the Supervisor-Password.

Approach

- Load your project into the operator panel.
- Press **ENTER** and navigate to the screen "Password". Via "Edit" you reach the password dialog. The password alteration is protected with the Supervisor-Password. In delivery state, the password is 100. Please regard that you may have to push **SHIFT** additional to the digit 1 depending on the project basic settings.
- Enter the password and confirm with **ENTER**.

Now you reach a table where you may enter a password for every level. For you may store up to 20 password assignments in the table, you may also assign more than one password to a level. **The password must have at least 3 digits and max. up to 8 digits. Characters and leading zeros are not permissible.**

The table has the following structure:

No.	Password	Level
0	_____100 (Supervisor-Password)	9
1	_____	0
	⋮	
20	_____	0

Navigation and delete password

The navigation happens with the arrow keys. You have to confirm every entry with **ENTER**. To delete a password, write a 0 (zero) over the password. The Supervisor-Password cannot be deleted.

ESC finishes the password entry and brings you back to the password screen. Via "Logout" you activate the passwords.

Fixed password levels

Please regard that the password levels for the following integrated standard screens are fixed in the operator panel:

- Level 9: Password Edit, OP-Mode
- Level 8: ForceVAR
- Level 6: System>MPI-Adr
- Level 4: System>Dat/Time
- Level 2: System>Language
- Level 0: Screens, StatVAR, Password>Logout

Chapter 6 General installation guidelines

Overview The chapter gives you information about the interference-free installation of Programmable Logic Controls (PLC) together with a CC 03. Here we describe possible paths how interference can enter the controller, how you ensure the electromagnetic compatibility (EMC) and how to approach shielding and screening issues.

Content	Topic	Page
	Chapter 6 General installation guidelines	6-1
	Basic rules for the EMC-equitable assembly of installations	6-2
	EMC-equitable assembly	6-6
	EMC-equitable cabling	6-7
	Special precautions providing high noise immunity	6-11
	Checklist for the EMC-compliant installation of controllers.....	6-12

Basic rules for the EMC-equitable assembly of installations

What is EMC?

The term electromagnetic compatibility (EMC) refers to the ability of an electrical device to operate properly in an electromagnetic environment without interference from the environment or without the device causing illegal interference to the environment.

The Operation Panels are developed for applications in harsh industrial environments and complies with EMC requirements to a large degree. In spite of this you should implement an EMC strategy before installing any components, which should include any possible source of interference.

Possible sources for disturbances

Electromagnetic interference can enter your system in many different ways:

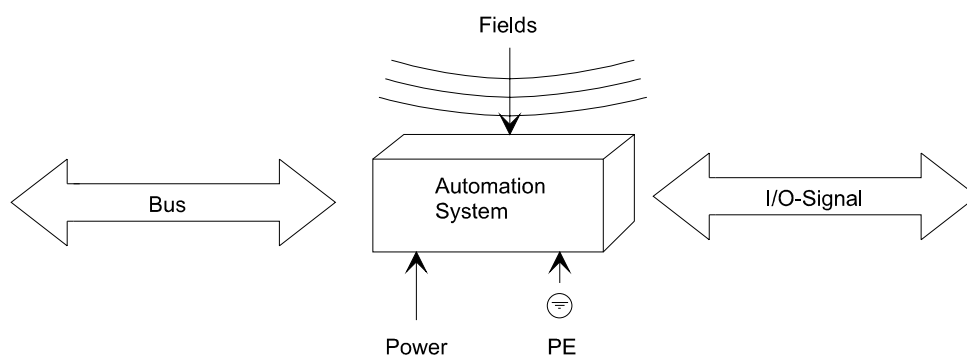

Interference is coupled into your system in different ways, depending in the propagation medium (conducted or not conducted) and the distance to the interference source.

We differentiate between:

- galvanic coupling
- capacitive coupling
- inductive coupling
- radiated power coupling

Coupling mechanisms and interference sources

The following table shows the four different coupling mechanisms, their causes and possible interference sources.

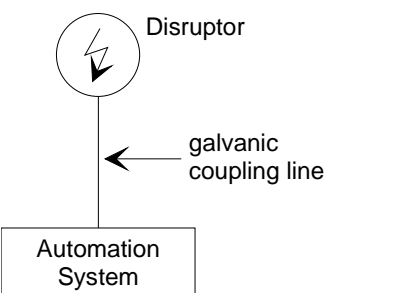
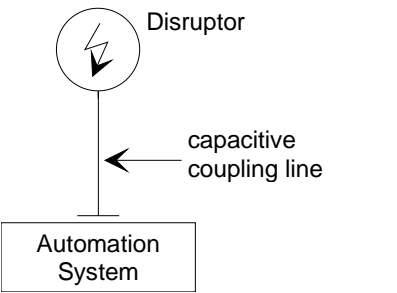
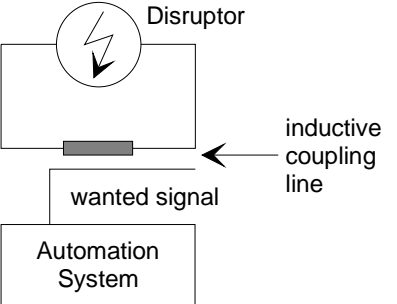
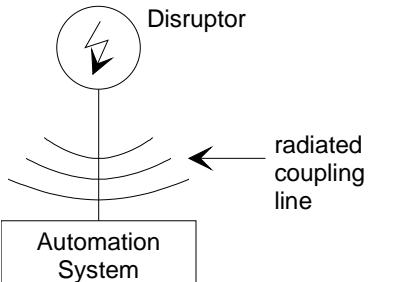
Coupling mechanism	Cause	Typical source
<p>Galvanic coupling</p> 	<p>Galvanic or metallic coupling always occurs when two current circuits have a common line</p>	<ul style="list-style-type: none"> • Pulsed devices (Net influence from transducers and foreign net devices) • Starting motors • Different potential of component cubicles with common current supply • Static discharges
<p>Capacitive coupling</p> 	<p>Capacitive or electric coupling occurs between conductors with different potential. The coupling is proportionate to the time characteristics of the voltage.</p>	<ul style="list-style-type: none"> • Interference through parallel signal lines • Static discharge of the personnel • Contactors
<p>Inductive coupling</p> 	<p>Inductive or magnetic coupling occurs between two current active line loops. The magnetic flows associated with the currents induct interference voltages. The coupling is proportional to the time characteristics of the current.</p>	<ul style="list-style-type: none"> • Transducers, motors, electric welding devices • Parallel net cables • Cables with toggled currents • Signal cable with high frequency • Unused coils
<p>Radiate power coupling</p> 	<p>One talks of radiate power coupling, when an electromagnetic wave meets a line circuit. The hit of the wave inducts currents and voltages.</p>	<ul style="list-style-type: none"> • Sender in the neighborhood (e.g. walkie-talkie) • Sparking lines (sparking plugs, collector of electric motors, welding devices)

Basic rules for ensuring EMC

In many cases, adherence to a set of very elementary rules is sufficient to ensure EMC. For this reason we wish to advise you to heed the following rules:

During the installation of your automation units you should ensure that any inactive metal components are grounded via a proper large-surface earth

- Interconnect any inactive metal components via low-impedance conductors with a large cross-sectional area.
- Execute screw connections at coated and anodized metal parts either with special contact washer or remove the isolating protective film.
- Install a central connection between the chassis ground and the grounding/protection system.

Ensure that cabling is routed properly during installation

- Divide the cabling into different cable groups (High voltage lines, power supply lines, signal lines, data lines).
- Always install high voltage lines and signal or data lines in separate channels or bundles.
- Install signal and data lines as close as possible to any metallic ground surfaces (e.g. frames, metal rails, sheet metal).

Ensure that the screening of lines is grounded properly

- Data lines must be screened. The screen has to be laid both-sided.
- Analog lines must be screened. Where low-amplitude signals are transferred it may be advisable to connect the screen on one side of the cable only.
- Attach the screening of cables to the ground rail by means of large-surface connectors located as close as possible to the point of entry. Clamp cables mechanically by means of cable clamps. Route the connected screen to the modules without interruptions, but don't connect the screen again.
- Ensure that the ground rail has a low-impedance connection to the cabinet/cubicle.
- Use only metallic or metalized covers for the plugs of screened data lines.

In critical cases you should implement special EMC measures

- Connect suppressors to all inductive loads that are not controlled by special EMC-modules.
- Use incandescent lamps for illumination purposes inside cabinets or cubicles, do not use of fluorescent lamps.

Create a single reference potential and ensure that all electrical equipment is grounded wherever possible

- Ensure that grounding measures are implemented effectively. The controllers are grounded to provide protection and for functional reasons.
- Provide a star-shaped connection between the plant, cabinets/cubicles and the grounding/ protection system. In this way you can avoid ground loops.
- Where potential differences exist you must install sufficiently large equipotential bonding conductors between the different parts of the plant.

EMC-equitable assembly

Mostly, measures for suppressing interference voltages are only taken, when the control is already in commission and the perfect receive of a wanted signal is disturbed.

Causes for such interference's are in the most cases inadequate reference potentials, coming from mistakes at the device assembly and installation.

Guidelines for assembling and grounding of inactive metal parts

When assembling the devices, you have to ensure the large-surface grounding of the inactive metal parts. A correctly done grounding supports an unambiguous reference potential for the control and reduces the impact of coupled interference's.

Grounding means the conducting connection of all inactive metal parts. The sum of all interconnected inactive parts is called Ground.

Inactive parts are all conductive parts electrically separated from all active parts by means of a basic isolation and that may only get voltage in case of an error.

The ground must not adopt dangerous contact voltage even in case of an error. Thus you have to connect the ground with the protected earth conductor. To avoid ground loops, local distant ground constructions (cubicles, construction and machine parts) have to be connected with the protected earth conductor system in star-topology.

Please regard at grounding:

- Connect the inactive metal parts as carefully as the active ones.
- Take care of impedance-low metal-metal-connections, for e.g. with large-surface and well conductive contacts.
- If you include coated or anodized metal parts in the grounding, you have to come through the isolating protection layers. For this you may use special contact washers or remove the isolation layer.
- Protect the connection points from corrosion, e.g. with grease.
- Moveable grounding parts (e.g. cubicle doors) have to be connected via flexible ground strips. The ground strips should be short and have a large surface, because the surface is decisive for the diversion of high frequency interference's.

EMC-equitable cabling

Line routing Content of this section is the line routing of bus, signal and supply lines. Object of the line routing is to suppress the "slurring" at parallel lines.

Line routing inside and outside of cubicles For an EMC-equitable routing of the lines it is convenient to divide the cables in different groups and install each group itself:

Group A

- screened bus and data lines
- screened analog lines
- unshielded lines for direct voltage $\leq 60V$
- unshielded lines for alternating voltage $\leq 25V$
- Coaxial cables for monitors

Group B

- unshielded lines for direct voltage $>60V$ and $\leq 400V$
- unshielded lines for alternating voltage $>25V$ and $\leq 400V$

Group C

- unshielded lines for direct and alternating voltage $>400V$

Group D

- Lines for H1 respectively TCP/IP

Combination of groups

Following the table you may see the conditions for the cabling of the line groups by combining the single groups:

	Group A	Group B	Group C	Group D
Group A	[1]	[2]	[3]	[4]
Group B	[2]	[1]	[3]	[4]
Group C	[3]	[3]	[1]	[4]
Group D	[4]	[4]	[4]	[1]

[1]	The lines may be installed in common bundles or cable trusses.
[2]	The lines have to be installed in different bundles or cable trusses (without min. distance).
[3]	The lines have to be installed in different bundles or cable trusses inside of cubicles and outside of the cubicle but inside the building in separated cable trusses with a min. distance of 10cm.
[4]	The lines have to be installed in different bundles or cable trusses with a min. distance of 50cm.

Line routing outside of buildings

Wherever possible, exterior cabling should be installed on metallic cable trays. A galvanic connection must be provided for joints between cable trays.

You must abide by the applicable lightning protection and grounding regulations when installing exterior cables.

Lightning protection



Attention!

Where cables and signal lines for PLC equipment are installed outside of buildings, the conditions for internal and external lightning protection must be satisfied.

- Exterior lines should either be installed in metallic conduit pipes that is grounded on both ends or in steel-reinforced concrete cable trunks with continuously connected reinforcing.
- Signal lines should be protected against overvoltage by varistors or by lightning arrester filled with rare gas.
- Install these protective elements at the location where the cables enter the building.



Note!

Any lightning protection system must be based on an individual assessment of the entire plant. For questions please contact VIPA GmbH.

Equipotential bonding

Potential differences may occur between different sections when controllers and peripheral equipment are connected by means of non-isolated connections or the screens of screened cables are connected at both ends and grounded on different sections of the plant.

One reason for a potential difference may be that different sections of the plant are powered from different power sources. These potential differences must be reduced by means of equipotential bonding conductors to ensure that the electronic equipment employed on the plant operates properly.

Rules for equipotential bonding

- The lower the impedance of the equipotential bonding conductor, the higher the effectiveness of potential equalization.
- The impedance of the equipotential bonding conductor must not exceed 10% of the impedance of the screen where screened signal lines are connected between the different sections of the plant and the screening is connected to ground/neutral on both sides.
- The cross-sectional area of the equipotential bonding conductor must be calculated to carry the maximum equalization current. The following cross-sections have been successfully employed:
 - 16mm² Cu for equipotential bonding conductors up to 200m
 - 25mm² Cu for equipotential bonding conductors exceeding 200m
- Use copper or galvanized steel for equipotential bonding conductors. These must be connected to ground/neutral by means of large-surface connections that are protected from corrosion.
- The equipotential bonding conductor should be installed in such a manner that it includes the smallest surface between the bonding conductor and the signal lines.

Screening of lines and cables

Screening is one method commonly used to reduce (attenuate) the interference pick-up from magnetic, electrical or electromagnetic fields.

- Interference on screens is conducted to ground by the conductive connection between the screen and the screening rain/enclosure. To avoid interference from these currents it is very important that the neutral connection is a low-impedance connection.
- You should only use of cables that are provided with a braided screen. The degree of screening should be more than 80%.
- Avoid cables with foil-type screens as the foil is easily damaged by tension and pressure at the point of attachment; this can result in reduced effectiveness of the screening action.
- As a rule you should always ground the screens of cables on both ends. This is the only way in which you can ensure that high frequency interference is attenuated properly.

One-sided grounding of screens

In exceptional cases it may be necessary to ground the screen on one side only. However, this will only attenuate the lowest frequencies. The one-sided grounding of screens may provide advantages when:

- It is not possible to install an equipotential bonding conductor
- Analogue signals (a few mV or μA) must be transmitted
- Foil-type screening (static screening) is employed.

You should always use metallic or metalized covers for serial data lines. Connect the screen of the data line to the cover. Do **not** connect the screen to PIN 1 of the connector!

In case of stationary operations it is recommended that the remove the insulation from the screened cable without cutting the screen and to attach this point to the screening/neutral rail.



Note!

Potential differences may give rise to an equalization current via the screen connected between the two ground connections.

In this case you must install an additional equipotential bonding conductor.

Connecting the screen

Please observe the following points when you handle the screens:

- Use only metallic cable clamps when connecting the screening of cables. These clamps must provide a good electrical contact and a large-surface connection to the screen.
- Attach the screens to the screening rail directly at the point where the cables enter the enclosure. The screening conductor must be continued to the module without interruption, however, it must not be connected to the module!

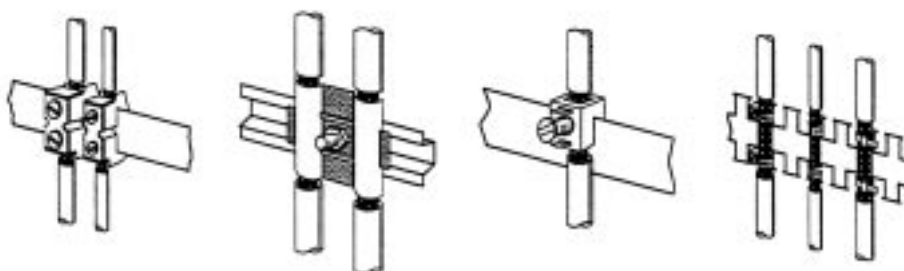

Special precautions providing high noise immunity

Inductors require suppressors

Inductors controlled by your programmable controller (e.g. contactors and relays) do not normally require suppressors as the respective modules have been provided with the required components.

Suppressors must only be connected to inductors when output circuits can be disabled by means of additional contacts (e.g. relay contacts). In this case the integrated suppressors on the module are also disabled.

You can connect diodes to suppress back-emf, varistors or RC-networks to the inductors.

Connections of DC-activated inductors using a diode

using a Z-diode

Connections of AC-activated inductors

using a varistor using RC-network

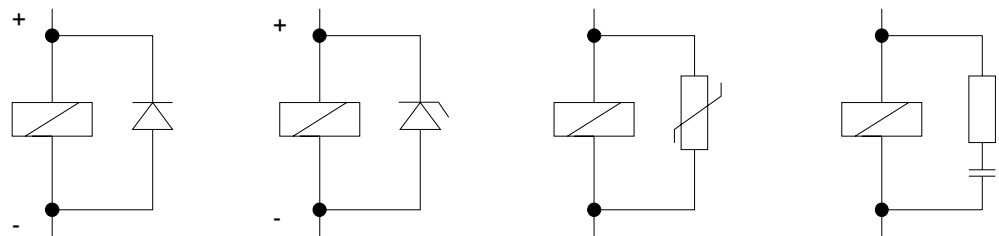

Power outlet for PGs

Every cubicle must be provided with a power outlet for the PGs. These outlets must be wired to the distribution system, which is also used to connect the neutral conductor for the cubicle.

Cubicle illumination

The cubicle illumination should consist of incandescent lights, e.g. LINSTRA-lamps. Avoid using fluorescent lamps as these lamps can cause interference.

If you can not avoid using fluorescent lamps you should implement the steps outlined in the following figure.

Suppression of fluorescent lamps in cubicles

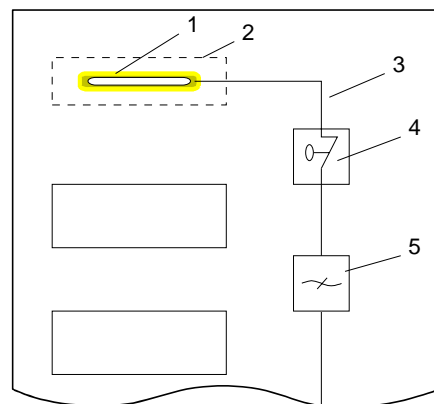

- [1] Fluorescent lamp
- [2] Screen above the lamp
- [3] Screened cable
- [4] Switch with metallic cover
- [5] Powerline filter or screened power cable

Checklist for the EMC-compliant installation of controllers

EMV-measures	Space for Notes
Connection of the inactive parts	
You should take special care to check the connections of: <ul style="list-style-type: none"> • Module racks • Frames • Screen and protected earth conductor 	
Are all the inactive metal parts interconnected by means of large-surface and low-impedance connections?	
Has a proper connection been installed with respect to the ground/protected earth conductor system?	
Has the isolation been removed from varnished and anodized surfaces or have these connections been fitted with special contact washer?	
Have the connection been protected from corrosion, e.g. by means of grease?	
Have doors been grounded by means of grounding straps connected to the body of the cubicle?	
Cable routing	
Cabling divided into groups?	
Power cables (230...400V) and signal lines installed in separate channels or bunches?	
Potential compensating	
When installing the equipment at separate locations, check the installation of the potential compensating line.	
Cable screen	
All covers of plugs are metallic?	
All analog and data lines installed screened?	
Line screens attached to the screening or the protected earth conductor?	
Have the screens been connected by means of large-surface and low-impedance cable clamps?	
Cable screens grounded both-sided where possible?	
Inductors	
Have the coils of contactors controlled by means of contacts been connected to suppressors?	