

Light Tower

LIGHT TOWER
AL4000



Light Tower AL4000

Features

- Full sized, 30 ft (9.1 m) extended height floodlight tower illuminates 7-1/2 acres.
- Galvanized tower is 360° rotatable for easy aiming from the ground.
- Winch handle ergonomically positioned for easy raising and lowering. Winch drum is inside cabinet. Electric winch available.
- Light fixtures mount securely on mast for travel or can be left on crossarm.
- Pallet pockets and lifting eye make unit easier to load and unload.
- Plug-in ballasts are installed in galvanized steel boxes.
- Light fixtures plug into weatherproof receptacle box with UL and CSA approved connectors.
- Retractable power cord automatically recoils into protective sleeve to prevent damage when raising, lowering and moving tower.
- Control panel located inside cabinet, protected from the elements.

Specifications

Lamps	Metal halide 4 x 1,000 W
Generator	Brushless 60 Hz, 6.0 kW
Engine	Kubota diesel 10.5 hp
Fuel capacity	30 gal (114 L)
Wheel size	15 in (38 cm)
Axle rating	3,500 lbs (1,588 kg)
Tongue weight travel position	100 lbs (45 kg)
Total weight no fuel	2,050 lbs (930 kg)

Dimensions

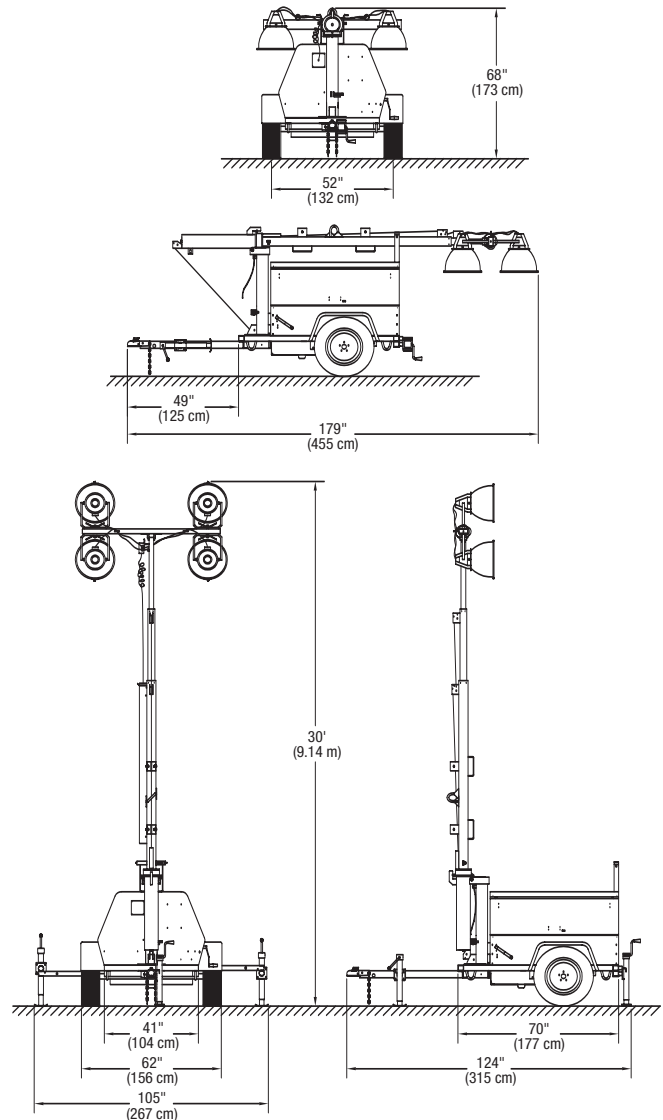

TEREX Light Construction

590 Huey Road TEL 803-324-3011
 P.O. Box 3147 TOLL FREE 800-433-3026
 Rock Hill, SC 29732 FAX 803-366-1101
 USA EMAIL sales@terexlight.com
 WEB www.terex.com

For more information, product demonstration, or details on purchase, lease and rental plans, please contact your local TEREX Light Construction Distributor.