



HARBORO
ENGINEERING IN RUBBER

THE HARBORO RUBBER CO. LTD

- Harboro first began trading in 1894 and has been working with rubber since its introduction as an engineering material
- Harboro has extensive laboratories and experienced, qualified engineers to develop solutions to customers' needs
- Harboro produces parts for a vast range of industries, including automotive, aerospace, general engineering, electronics, defence, oil, gas, marine, footwear - in fact, most sectors of manufacturing industry
- Harboro is equipped to mould any number of parts economically - from one to many millions
- Harboro is delighted to give advice on materials and processes, supply samples and mould prototypes

The Harboro Rubber Company Ltd
Riverside, Market Harborough
Leicestershire LE16 7PZ, UK

tel: +44 (0)1858 410610
fax: +44 (0)1858 410006
e-mail: help@harboro.co.uk



HARBORO
ENGINEERING IN RUBBER

ENGINEERING IN RUBBER



INTRODUCTION

When I first came into the industry, I was struck by the lack of easy-to-use technical information available to designers using rubber. From this, the first edition of Engineering in Rubber was born and it has proven very popular since the day it was launched. It is now in global demand.

In my time at Harboro, the company has been involved in the design and production of some 6,000 rubber components. In my years of working with customers if there is one outstanding lesson, it is that the earlier a designer involves the rubber engineer, the greater the benefits in terms of cost, design effectiveness and ease of production. This leads to the supply of high quality, low cost, trouble-free components. Little or no advice frequently leads to unnecessarily higher costs.

Out of these lessons, we have built a company based on partnership with our customers. Currently 98% of our customers experience zero quality complaints per annum. Of those providing regular feedback 97% rate us as 'excellent'.

Harboro's philosophy is that: "The most successful business outcome between two companies will arise from a thorough knowledge of each other's needs and processes. This, through close technical co-operation, will lead to the design and development of the most cost-effective parts which will be problem-free, allowing zero defects in production and providing the basis for continual cost improvement."

It is Harboro's mission to seek such partners.

I commend this new fifth edition of Engineering in Rubber to you in the hope that it will further the knowledge of designers and support co-operative developments in the design of rubber components throughout the world.



JAMES BRIGGS
Chairman



CONTENTS

VALUE OF RUBBER	4-6	DATA CHART	16-17
Resistance to Hostile Environments			
Weather Resistance			
Extremes of Temperature			
Hardness & Softness			
Elasticity			
Electrical Properties			
Resilience & Energy Control			
PROCESSING RUBBER	7-11	RUBBER DIRECTORY	22-25
Compounding		Natural Rubber	
Pre-forming		Epdm	
Moulding		Neoprene	
Finishing		CSM	
Inspection		Nitrile	
Critical Control		Acrylic	
Laboratory Checking		Vamac®	
Reverse Engineering		Thermoplastic Rubbers (TPRS)	
Surface Analysis		Silicone	
Manufacturing		Fluorocarbon (Viton®)	
		Fluorosilicone	
		SBR (Styrene Butadiene Rubber)	
		Specialist Elastomers	
		Therban (HNBR)	
		Epichlorohydrin	
		Liquid Silicone	
DESIGNING WITH RUBBER	12-13	GLOSSARY OF TERMS	26-27
Designing for Minimum Costs			
Producing a Specification			
Prototyping			
Designing Components			
CAD			
Tooling Design			
Cost			
Colour			
Surface Finish			
Materials			
Tolerances			
Quality			
SPECIFYING RUBBER	14-19	MEASUREMENT OF RUBBER PROPERTIES	28-29
Selecting the Most Cost-Effective Suitable Rubber			
Material Selection Chart			
Defining Basic Mechanical Properties			
Typical Tensile Strengths			
Typical Compression Set Values			
Defining Other Mechanical Properties			
Defining Electrical Properties			
ASTM & BS Framework for Specifying Rubber Materials			
Line Call Out			
		HEALTH & SAFETY	30-31
		Material Data	
		Fire & Explosion Hazard	
		Health Hazard Data	
		Company Statement	
		General Guidelines	
		TRUE PARTNERSHIP	31

VALUE OF RUBBER

Rubbers have found many applications in industrial and consumer goods because they are the only group of materials able to provide elastic properties across a wide range of temperatures (well above and below the temperature ranges of plastics and other elastic materials).

The rubber family includes a diverse range of materials - as varied as metals. Currently we use 250 grades of rubber across 14 different polymer types (each as different as lead, iron, copper, silver or gold).

A hundred years of research and development cannot be fully covered in a short guide, but the main properties are summarised below with examples of actual applications.

Designers choose rubber because of its wide range of properties:

- It can be used over a temperature range from -80°C to +300°C
- It is available in a wide range of colours
- It can be electrically insulating, conductive or anti static
- It can withstand extremes of weather and outdoor environments indefinitely
- It can withstand exposure to fuels, oils and chemicals while retaining its properties
- It can be made flame retardant and self extinguishing, with halogen free and smoke suppressant types available
- It can maintain tension and compression forces indefinitely - for example in seals
- It is conformable, adaptable and can accommodate movement, shock, thermal changes, tolerances and roughness
- It can absorb vibration and noise and act as an insulator
- It can be gas tight and used as a fluid seal or separator
- It has low thermal conductivity and can be used to reduce heat transfer
- It has friction properties similar to human skin and is comfortable to grip
- It can have a clean, smooth surface which is non-stick and suitable for hygienic applications
- It is compatible with other engineering materials (e.g. metals, plastics and ceramics) and can be combined with them in many different ways, including bonding.

Many of these properties can be combined by suitable compounding, although no single material is "best" in every aspect. Some properties are only available in one type of rubber. Let us look at some of these properties in more detail.

RESISTANCE TO HOSTILE ENVIRONMENTS

The development of synthetic rubbers stemmed from the need to create materials with greater resistance to fuels and oils. Aggressive chemicals, hydraulic oils, food substances and refrigerants all have to be contained and a wide range of rubbers have been developed to resist most fluids and chemicals. Rubbers have to be carefully selected, formulated and tested to ensure safe and predictable service lives.

Major Materials

- For moderate resistance to oils and fuels - Neoprene, CSM
- Good resistance to oils and fuels - Nitrile, Acrylics, Silicones
- Extreme resistance to many chemicals - Acrylics, Fluoroelastomers, Fluorosilicones
- For a comprehensive list of suggested rubber types for resistance to named chemicals, consult ISO Technical Report 7620 or the Fluid Sealing Association Technical Handbook.

WEATHER RESISTANCE

Suitable rubbers will retain their properties indefinitely under all weather conditions - hot, cold, dry, wet or humid. Many can be quoted for a 50 year life exposed to weather.

Major Materials

EPDM rubbers have exceptional resistance to water and ozone attack while Silicones are unaffected by extremes of weather. CSM and Fluoro based rubbers also resist weather indefinitely.

EXTREMES OF TEMPERATURE

Apart from Silicone, rubbers are essentially hydrocarbon materials and perform within a limited range of temperatures. Where working temperatures are quoted, these represent the range within which the rubber's properties are maintained more or less indefinitely. Temperatures lower than the minimum will always stiffen the material (although it will relax again as the temperature rises) and extremely low temperatures may turn it brittle. Temperatures higher than the maximum will degrade the rubber, ultimately destroying it.

Typical Applications

Where service temperatures are known, the best types of material can be selected to provide adequate life under those conditions. Temperature guidelines are provided in the Data Chart (see pages 16-17), covering the range from -80°C to +300°C.

In vehicles, under-bonnet components are required to perform reliably in a high temperature environment while being exposed to hot oil, brake fluid and other chemicals. In other countries, the same components must function even when subjected to high wind chill factors - in Scandinavia for example sometimes reaching -50°C.

Examples of Components

Furnace rod control seals operating at continuous temperatures of 250°C. Telescope eyepieces which must remain flexible and comfortable even in Arctic conditions.



HARDNESS & SOFTNESS

The property of hardness is easily recognised, but in design terms it must be specified to achieve a given objective. Solid rubbers range from 20° to 98° Shore A, where 20° is extremely soft like foam and 98° is as hard as wood or nylon. For rough reference, the ball of the human thumb is 25°, a Staedtler white rubber eraser 55° and a bath plug 95° Shore A.

The hardness of rubber is measured in a number of ways, including IRHD and is described in more detail on page 28-29.

Typical Applications

Designers use rubber in its whole range of hardnesses and each application has to be individually considered. Once a mould has been produced, it is relatively easy to make the same part in other colours and hardnesses to suit different functions.

Whatever the hardness required, it may still be necessary for a rubber component to deform in order to seal against an uneven surface or to resist abrasion.

Major Materials

All rubber types can be compounded to cover most of the range of hardnesses from 30-90° Shore A. Lower and higher hardnesses require special compounding.

Examples of Components

Hardness is required in a part designed to grip paper rolls. It must resist abrasion and not distort in operation. Conversely, rubber suckers used to lift paper sacks have to be very soft to conform to the rough and porous surface.



ELASTICITY

The ability to expand greatly and to return quickly is what distinguishes a rubber from a plastic. This property not only makes possible the catapult but also allows designers to use rubbers to supply constant forces, either in tension or compression. True rubbers maintain this elasticity (and ability to seal) across a wide range of temperatures.

Typical Applications

High quality rubber compounds will remain elastic for their full design lives, virtually irrespective of the movement cycles they undergo. However, all rubbers will relax to some extent under constant deformation and this should be specified if significant. Rubber is thermoset and resists permanent deformation across a wide temperature range. Considerable care should be taken when considering thermoplastic rubbers (plastics with rubbery properties rather than true rubbers) which relax significantly under stress, particularly at temperatures over 70°C.

Where rubber is to be used continuously in tension, consideration should be given to the effects of failure and trials carried out as required.

Major Materials

All rubber types are elastic. Natural rubbers are tough and strong but may have limited life if exposed to ozone or sunlight. Thermoplastic rubbers generally have lower elasticity and the softer grades relax when deformed, giving rise to permanent set.



VALUE OF RUBBER

ELECTRICAL PROPERTIES

Rubbers can have a wide variety of electrical properties (including piezo electric and magnetic) and by suitable compounding can be made highly conductive or totally insulating. Most antistatic or conductive rubbers are based on carbon incorporated into the rubber. Harboro Rubber has the only known coloured antistatic rubber which was developed in its laboratories.

Typical Applications

Conductive rubber is used in electronic equipment for switching, keypads and continuity as well as static dissipation. Insulating rubbers are used extensively in electrical termination and switchgear components, grommets and weather seals. Anti-static rubbers are commonly used in operating theatres, explosive factories and electronics manufacturing areas.

Major Materials

All types of rubber can have varied electrical properties and a wide range of compounds can be produced for different applications. Silicone rubbers can be made highly conductive by adding silver particles or, more normally, carbon.

RESILIENCE & ENERGY CONTROL

Resilience is the property of absorbing energy by deformation and returning a proportion of it on rebound. Depending upon the rubber type and compound, some of the energy will be converted into heat within the material. A high resilience material returns almost all the energy - for example a superball which gives over 90% bounce - while a low resilience material has a low rebound, giving a "dead" feel, such as a squash ball or high performance tyre.

Typical Applications

Rubbers have always been used for energy control purposes. These range from the simple parts - buffers, elastic bands and sports equipment - to the more complex parts such as car suspension systems or keypads, where rubber provides that delicate, precise "feel".

Rubber is also valued for its vibration control. It is extensively used in flexible couplings where rubber "spiders" allow misalignment, reduce jamming and have the resilience to damp out vibration.

Major Materials

All rubber types can be used for energy control and can be compounded to vary their fundamental resilience to the exact requirements of the designer. Fine tuning of the characteristics can be achieved by small changes to the shape of the moulding.

Examples of Components

Keypads which have to be designed and moulded to the closest tolerances in order to achieve precise force/travel characteristics over millions of operations.



PROCESSING RUBBER

COMPOUNDING

Raw rubbers have few uses in their natural state. To achieve the desired range of properties, the raw rubber must be combined with a range of additives. The selection of appropriate additives, and their skilful and consistent mixing, is known as compounding.

The additives in a rubber compound may vary from 2-3% (in the case of a rubber band) to over 60% by weight and will include some or all of the following:

Curatives

Active chemicals which bring about the cross-linking of the long chain rubber polymer. Sulphur was the first to be discovered and is still commonly used.

Accelerators

Chemicals which vary the speed and timing of the curing reaction.

Reinforcing Fillers

Materials which increase the strength of the material. Carbon black and silicas are the most commonly used.

Fillers

Relatively inert chemicals, such as clays, which increase the bulk of the compound. (Excess use of inert fillers can cheapen materials but often has an adverse effect on performance.)

Pigments

Added to produce specified colours. They can only be used with compounds which do not contain carbon black.

Plasticisers

Added to aid processability or to produce specified properties.

Anti-Oxidants/Anti-Ozonants

Chemicals which are added to help the compound resist surface attack, especially by ozone.

Process Aids

Resins, soaps, low-weight polyethylene.

The constituents are weighed out and combined by a mixing process which must blend the ingredients thoroughly in a repeatable way. This is achieved either by an internal mixer, where the compound is mixed by two meshing rotors in an enclosed case; or by open mill mixing, adding the ingredients carefully into the "nip" between two steel rollers, typically of 30" diameter.

The result of either process is a batch of uncured rubber compound. This is allowed to settle for a time before undergoing Quality Assurance tests. Once passed, it can be formed into suitable shapes for moulding.

PRE-FORMING

Each moulding process has its own requirements for uncured material. Compression moulding, for example, requires a "blank" of material in a size which will fill the cavity exactly. Direct injection moulding needs relatively large quantities of compound in a continuous strip. Due to the nature of the injection process, material properties must be precisely measured and controlled to achieve the planned flow and cure behaviour, as well as the desired final characteristics of the rubber.

A variety of processes are used to produce material suitable for moulding:

Sheeting

Uncured material is produced in sheets of the desired thickness. Sometimes "blanks" are cut from the sheet, like pastry cutting.

Extrusion

Extruders force warmed compound through a shaped die. Any reasonable length of shaped material can be produced. Once cooled this is fed into the direct injection presses.

Pre-Forming

Extrusions as above are cut to required lengths as they emerge from the die. This process can be accurately controlled to produce blanks of precise volume for compression moulding.



PROCESSING RUBBER

MOULDING

Rubber can be made into components by a number of processes, including extrusion, calendaring, coating onto fabric and moulding. Harboro has concentrated on moulding in all its aspects and operates a wide variety of machines using all the common moulding processes.

The choice of moulding method will depend upon factors such as the finish desired, the number of components required, the money available for tooling etc., and should be discussed in detail with a rubber manufacturer.

The basic processes of moulding are:



Compression

A piece of uncured rubber of the correct geometry is placed between two halves of a heated mould. The mould is closed in a press under a pressure of around 14 MPa and the rubber is forced into the exact shape of the cavity. The rubber gains heat by conduction from the mould surfaces and "cures". When the rubber has had sufficient time to cure, the mould can be opened and the part removed.

Compression moulding is a relatively simple process and is often used for components required in fairly low quantities. Mould costs are generally lower.

Parts moulded by this method will always have some flash because the mould surfaces are held apart by the necessary excess rubber in the "blank".

Transfer Injection

The heated mould is closed in a press and the rubber injected by a hydraulic cylinder through a feed hole in the cavity. The cylinder can either be incorporated in the press or sometimes in the mould.

Provision must be made for air to escape from the cavity as the rubber enters, and the feeding method chosen to suit the operational requirements of the part.

This method of moulding can produce high-precision parts in moderate quantities without high tooling costs. In the simplest case, the mould can be the same as a compression mould with the addition of a feed hole. Maximum weights and number of cavities are governed by the capacity of the transfer cylinder and the clamp pressure.

Direct Injection

A screw injection system delivers a metered quantity of rubber into the closed mould. The injection unit is fed from a continuous strip or a reservoir of uncured rubber and pre conditioned to provide the very best material characteristics for introduction into the cavity.

This process is generally used for multi-cavity moulds and can produce hundreds of components per press cycle. Because of the amount of rubber in the system, it is inadvisable to change materials frequently.

Large moulds require complex feed systems to balance the pressures in each cavity. Generally these are in the heated top half of the mould and cure at the same time as the components. Unlike thermoplastics, cured thermoset rubber cannot be reground or reused and the additional waste has to be included in the material usage per piece. Where very large volumes of mouldings are required, cold runner systems should be considered. These are justified by material savings over £10,000 pa.

Direct Injection lends itself to relatively large quantities, a large number of cavities and infrequent changes of materials or moulds. Parts are repeatable and can be made to a high level of precision.

FINISHING

Compression moulded and some injection moulded parts require deflashing. This is done in various ways depending upon the shape and size of the component and the type of rubber used.

Sub-Zero Finishing

The most modern and efficient method of finishing uses cryogenics. Parts are frozen to temperatures as low as -120°C and then tumbled and/or bead-blasted while cold to remove the brittle flash. The machines are individually programmed with the optimum temperature and running times for each particular type and number of components, which are tested and proven during the development stages.

Tear Finishing

The tool is designed to produce a very thin section of flash around the part which is torn off at the press during de-moulding.

If required, components can also be hand finished by the following methods:

Buffing

Parts can be smoothed using a variety of abrasive belts, wheels and mops.

Cutting

Parts are die cut by machine using a range of tools from precision steel knives to wood-formers, or in extreme cases are trimmed with scissors.

INSPECTION

Tight manufacturing controls with well designed processes coupled with operator knowledge and vigilance make it possible to produce parts with very low defect levels. While this is common at Harboro Rubber, the variability of materials in rubber processing prevents many from achieving zero defects. Unlike plastics and metals, variability in rubber processing is very high since the material cross links with time and temperature and radically changes its flow properties (doubling the speed of change for every 10°C rise). Variations in mixing, storage and preparation and changes of temperature with flow (particularly through restrictions such as injection gates where temperatures can rise 20-30°C), prevent most factories from achieving zero defects. This leads to the need for expensive visual inspection.

Human visual inspection methods are limited even with multiple inspections. 50-100PPM is probably the best achievable on non critical parts where faults are readily recognisable. This is a satisfactory level in many commercial situations. However, with the trend for increasing liabilities there is growing demand for zero defects. Harboro Rubber employs computerised camera inspection where near zero defects is truly required.

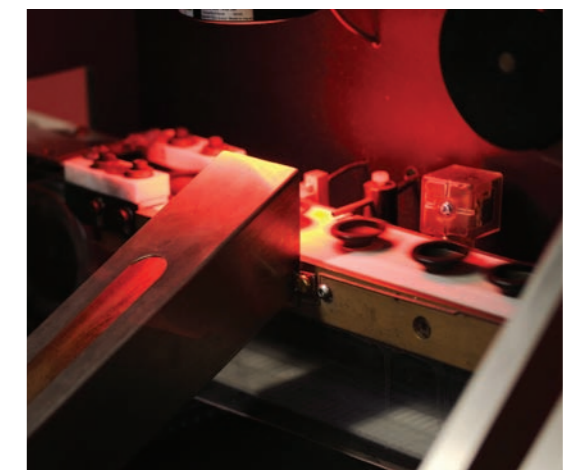

PROCESSING RUBBER

CRITICAL CONTROL

The liability in manufacturing grows as each year passes. A manufacturer must be certain of their products and able to demonstrate this both by testing and through the traceability of the materials and processes used. Harboro have one of the best equipped laboratories in the industry and an approach to quality control which ensures reliable parts through the application of high technologies for material analysis and inspection.

LABORATORY CHECKING

It is difficult even for highly qualified material technologists or chemists (of which Harboro employs four), to determine the characteristics of a material without the use of testing equipment. Traditionally tests are carried out on carefully prepared test sheets under supervised conditions but these are not always truly indicative of the parts being manufactured. Finished part testing is therefore crucial for many components in today's applications. Finished part testing requires different equipment and testing and is not available in many rubber companies.

Harboro has been involved in global procurement for some parts since 1996 and has developed expertise and acquired specialist equipment suited for such testing. A dedicated laboratory team control the supply of both in house manufactured and globally procured mouldings. In-house manufacturing materials are not an issue as all compounds being supplied to Harboro are carefully tested but globally supplied products needed a different approach. An investment program over a number of years was undertaken in order to elevate the laboratories quality control and analytical capability, allowing detailed analysis of finished parts by the determination of not only the physical attributes but the composition of finished parts.

The composition is critical to the functionality of the product and a key test is using Thermo Gravimetric Analysis (TGA). This test is described below. Although TGA has become an indispensable tool for the analysis and characterization of materials, its scope is limited and at Harboro Rubber Company is used for high level quality control.

As a standalone application the data can be used as a comparator against the approved material but no information is obtained about the qualitative aspects of the evolved gases during the thermal decomposition. For processes involving mass loss, a powerful technique to provide this missing information is Fourier Transform Infrared spectroscopy (FT-IR) in combination with TGA. This supplies a comprehensive understanding of thermal events in a reliable and meaningful way as data are obtained from a single sample under the same conditions. This provides extremely accurate and detailed information about the composition of the material thus allowing comparison against a stored material data base and analysis for development and reverse engineering.

These tools allow us to 'see into' any finished part material. We can pick up any changes or deviations that exist in the material. This resource ensures that suppliers abroad cannot change materials without notification and our prior agreement. Many companies have come to serious grief with suppliers who have changed materials without notification, often for cost or convenience reasons, which is a common practice in Far Eastern manufacture. We can ensure that such practices do not take place amongst our suppliers.

Thermo Gravimetric Analysis (TGA)

The Q500 is the world's number 1 research-grade thermo gravimetric analyzer. Its field-proven performance arises from a responsive low-mass furnace, ultra-sensitive thermo balance, and efficient horizontal purge gas system (with mass flow control). Its convenience, expandability and powerful, results-oriented software make the Q500 ideal for the laboratory where a wide variety of TGA applications are conducted, and where future expansion of analytical work is anticipated.

Fourier Transform Infrared Spectroscopy (FT-IR)

FT-IR – Nicolet 380. Harboro combine the quantitative analytical attributes of the Q500 (TGA) with the high level qualitative capability of the Nicolet 380 (FT-IR) to provide a detailed analysis of any material which decomposes below a 1000 degree ceiling at molecular level. The reflective chamber can also be used for non-destructive testing to provide a rapid surface composition analysis. This equipment is invaluable for quality control, fault analysis and reverse engineering.

REVERSE ENGINEERING

One very obvious and much used application for the TGA and FTIR is that of reverse engineering. Both types of analysis when combined provide very detailed information about the back bone of the material used to manufacture products and is only limited to the thermal ceiling of 1000°C.

SURFACE ANALYSIS

In conjunction with the FTIR chamber Harboro installed a Reflective Infrared Surface analyser and this provides a very quick and useful test to determine further information on surface contamination and material composition.

Hardness Analysis on Small Components & O Rings

Further addition to Harboro's well equipped laboratory to improve control and analysis is the inclusion of Bariess Digital hardness testing. This equipment removes the manual element from hardness testing and therefore result variability is reduced. Its multi head design offers great versatility and is used for goods inwards control of compounds, development and for control of globally procured products.

MANUFACTURING

PPM targets are ever decreasing and constantly have to be revisited. Manufacturing has to respond in the most appropriate manner. The PPM figure in most cases was originally deemed as a target but as most manufacturers know, targets quickly turn into measures and cost. Understanding a customer's real needs from the onset of any project is paramount in planning to achieve the lowest possible PPM figures. Continuous improvement and total quality management are deemed as processes to achieve the illusive actual zero defects. Many companies have spent a lot of resources working to reduce the level of defects from a process only to find that the number of variables which they have to contend with within the commercial boundaries mean that zero defects cannot be achieved solely through process improvement. Manual inspection is costly and provides unpredictable and low confidence results (100ppm is the best achievable on non-critical parts where faults are readily recognisable). The cost and unreliability has driven a different approach at Harboro.

Harboro still carry out manual inspection where applicable but, where products or agreements dictate, we apply high technology automated inspection systems. Harboro has invested in three automated systems which can process a broad range of products and are planning for further additions in the future.

This does not mean that zero defects can be guaranteed but extremely low PPM figures can and will be achieved where required, thus reducing costly reject management exercises at our customers. The cost of initial set up can prevent it at first seeming the lowest cost option but over time it will provide the lowest total acquired cost and a concern free product life.

The Harboro Rubber Company Automatic Inspection Department

3 camera inspection system. This equipment is used for the inspection of high specification thermostat seals at thousands of parts per hour.

O Ring & Circular Product Checking System

This equipment carries out instant non-contact dimensional checking of circular products and provides full statistical analysis.

Semi automated Modular System

This non-contact measuring device can be programmed to accommodate irregular shaped products for high speed single face inspection.



DESIGNING WITH RUBBER

DESIGNING FOR MINIMUM COSTS

While every component is designed to fulfil a unique set of operational requirements, there are a number of common principles which will reduce the time and cost of obtaining an economic component. Many of these are self-evident but some require an understanding of the differences between moulding thermoset rubber and moulding plastics.

Parts will be obtained at minimum cost when there are no surprises in the design, supply or use. Good communication and early contact with suppliers, particularly during the development of new parts, will highlight potential areas of uncertainty and allow them to be overcome. Advice at an early stage can often add functionality to the design which saves cost in other areas e.g. easing assembly, simplifying design or reducing tolerances required in other components.

PRODUCING A SPECIFICATION

Designers are strongly advised to consider and record a specification covering the following points:

1. What operating conditions are expected - normally and exceptionally?
2. What substances will be encountered?
3. What will be the likely material? (See pages 14-17 for the selection process)
4. Will there be any movement or distortion?
5. What are the price targets? Are there any tool cost constraints?
6. What colour should the component be?
7. What finish is required?
8. What quality standards will it have to meet?
9. How many are likely to be required?
10. What amount and position of flash is allowable?

A specification is invaluable in selecting a suitable material for trials, as well as being a sound basis for producing parts which are safe and economic by design. Over-specification may lead to the use of an expensive polymer, an inappropriate tool or unnecessarily costly processing.



PROTOTYPING

A single cavity prototype can be produced quickly and economically. This allows designs to be proved, materials tested and a small number of parts supplied for pre-production runs. Harbora offers a priority service for prototype moulds which can generally be obtained in less than four weeks.

DESIGNING COMPONENTS

The following should be borne in mind at the design stage:

- Be aware of where the split line will fall
- Think about removing the part from the mould when it is hot and soft
- Rubber parts do not generally need taper
- Re-entrant shapes are practical in rubber
- Core out thick sections which would extend cure times
- Geometric shapes make for economic tools
- Combine features - such as seals, springs, logos and tolerance take-up from other parts.

CAD

The days of hard copy drawings have been for many years apparently on the endangered list but thankfully for many they remain. Hard copy drawings still provide detailed information on specifications tolerances notations and something that everyone can use through the control documentation from goods inwards to despatch. Every customer has different methods for which part drawings and designs are transmitted. On a day to day basis Harbora are working with companies that do not have the resources to create CAD models and in some cases even hard copy drawings. This is not considered as being a problem as Harbora can work from just ideas, concept or sketches up to the most complex CAD model and turn it into reality. Harbora has the breadth of skills available to work with a customer to provide well designed solutions using in house CAD and FEA software. This is completed with the input of material technologists, process specialists and our in house tool design engineer. The combination of experience, knowledge and innovation is a rarely found package.

TOOLING DESIGN

There are significant differences between moulds for thermoset rubber and for plastics which the designer should take into consideration.

Thermosetting materials are cured by heating to around 150°C. Much of this heat is gained from the hot tool walls. As rubbers are good insulators, heat transfer can be slow where the part has thick sections.

Unlike thermoplastics, the flash, feed gates, runners and sprues of thermoset rubbers are cured irreversibly and are not reusable in any way. Flash is characteristic of normal rubber moulding, as rubbers do not “freeze” as plastics do when flowing into very thin sections and will run into gaps as small as 0.002mm.

Designers should not specify the number of cavities in a tool as economic production depends on a number of factors, including:

- the precision required
- the dimensions and orientation of the part
- press characteristics
- the quantities and rates required.

There is often a variety of possible ways to mould a component. For example, a cylinder can be moulded with the tool split line parallel to or at right angles to the axis. This decision affects the number of cavities possible and the appearance and price of the finished part. It will often depend upon the amount of visible flash allowable at the tool split line. The final choice will be governed by the function of the part, the appearance required, the economics of tool area and tolerances.

Most production tooling for rubber parts is made of mild steel. A few compounds give off halogens as they cure which, in the long term, can corrode the mould surfaces but otherwise rubbers are not aggressive materials. When injected, they flow reluctantly and require large gates and feeds compared to plastics, so abrasive wear is minimal.

Tools are generally expected to last around 100,000 press lifts - a four cavity tool should produce 400,000 parts during a normal life. Precision parts and tight tolerances generally mean shorter tool life and higher maintenance costs. Frequent changes and short runs also reduce life expectancy. All tooling will require periodic refurbishment and should be reviewed annually.

Tool design is best discussed with the rubber manufacturer at an early stage.

Harbora’s in-house technical team includes an experienced toolmaker and tool designer.

COST

The key determinants of cost are cycle time, the number of cavities in the mould, material cost and the need for manual operations before or after moulding.

Cycle times for rubber generally range from two to ten minutes, although the cure time for heavy parts may be much longer than this. Reducing the mass of a component not only reduces the material cost, but may also reduce the cycle time. This is especially true for parts with thick sections.

Where zero defects are required, due recognition of process capability is required in order to prevent unnecessary quality inspections after moulding. Checks that are not built into the process will inevitably add to the cost (see Quality in Rubber, page 20-21).

COLOUR

Rubber gains much of its strength and its resistance to heat and light from the addition of carbon black. Hence the vast majority of rubber is black.

Coloured rubbers can be produced using other reinforcing fillers and suitable colouring pigments.

However, the changes that take place during curing, and the nature of the moulding process, make it difficult to maintain perfectly even coloration, particularly with pale colours. Silicone rubbers are the most suitable for achieving reliable and clean coloured mouldings, even with pale colours and translucent.

SURFACE FINISH

The finish of rubber can range from semi-gloss to extremely matt using the same mould, but it will always be less smooth and mirror-like than plastic. The matt, non-reflective nature of their surface means that coloured rubbers will have a different appearance to neighbouring “hard” materials.

Attractive appearances can be obtained by moulding a patterned surface into a component, such as a fine matt geometric pattern or “sparkled” finish.

MATERIALS

Harbora is happy to advise on the most economic materials for any application. The company will supply free samples of materials in 7x7cm (approx) sheets to allow different compounds and hardnesses to be trialed. Of course, any material proposed should be well tested before production commences.

Some materials are very expensive but on small complex parts the material cost may not be that significant. However, on tiny, thin parts, the weight of flash, sprues and runners may be large compared with the component itself.

Each mould is made to allow for the shrinkage of a specific compound. Rubber compounds of the same type have similar shrinkages - harder compounds shrink slightly less. It is possible to change compounds in a mould but the finished dimensions may vary if the shrinkage is different.

TOLERANCES

The finer the tolerances required, the more costly the part.

Tolerances for moulded products to ISO 3302 1995 (BS 3734)

Table classes M1 (Precision) and M2 (Commercial)

Values in mm

F = Fixed dimensions

C = Closure dimensions

Nominal Dimensions		Class M1		Class M2	
Above	Up to	± F	± C	± F	± C
0	2.5	0.08	0.08	0.10	0.15
2.5	4.0	0.08	0.10	0.10	0.15
4.0	6.3	0.10	0.10	0.15	0.20
6.3	10.0	0.10	0.15	0.20	0.25
10.0	16.0	0.15	0.20	0.25	0.30
16.0	25.0	0.20	0.25	0.25	0.35
25.0	40.0	0.20	0.25	0.35	0.45
40.0	63.0	0.25	0.35	0.40	0.50
63.0	100.0	0.35	0.40	0.50	0.65
100.0	160.0	0.40	0.50	0.70	0.90

All dimensions in mm

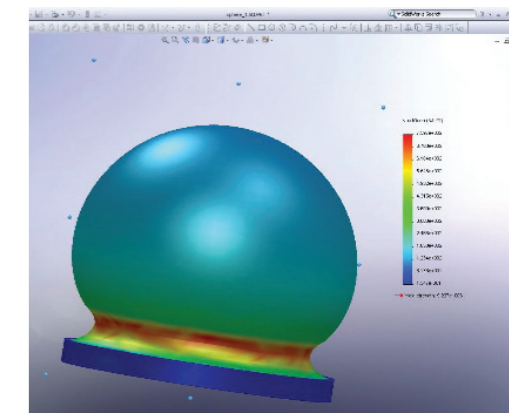
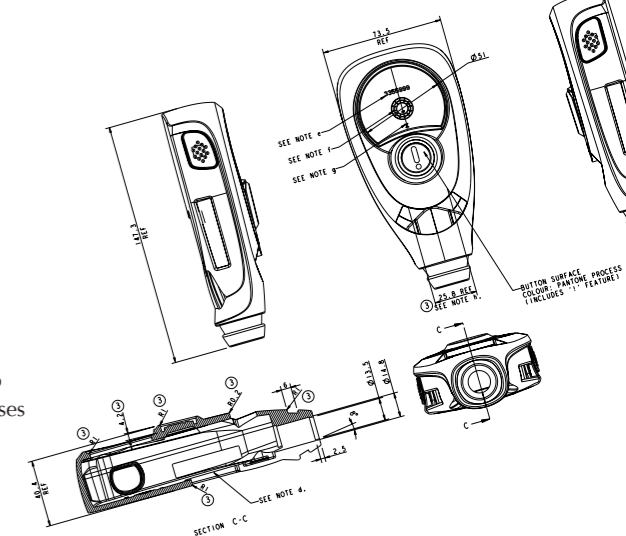

QUALITY

The lowest cost of quality is obtained when it is built into the development process by agreement. 'Inspecting it in' at a later date is relatively expensive. (See pages 20-21 for further information.)

Harbora is approved to ISO 9001:2000, automotive standard TS 16949:2002 and many other standards.

SPECIFYING RUBBER

SELECTING THE MOST COST-EFFECTIVE SUITABLE RUBBER

Two properties more than any other are dependent on the choice of rubber type - temperature range and fluid resistance. To a lesser degree, long-term weather and ozone resistance are also affected by the type chosen and this should be borne in mind if relevant.

To select the most suitable rubber the following information is required:

- What is the highest temperature likely to be encountered in service?
- What is the highest temperature at which continuous service will be required?
- What is the lowest temperature at which the component must remain operable?
- What fluids will be encountered in service and at what temperature?
- Is the frequency of contact with the fluid continuous, intermittent, or very occasional (e.g. accidental contamination)?

f) Is long-term weather or ozone resistance an important factor?

The chart below shows the different rubbers and their properties as related to these questions. The cost factor is also shown, with the rubbers arranged in order of increasing cost from left to right.

Starting at the left, check the properties of the rubber against your answers to the questions above. Keep moving to the right until a rubber is found that meets your need. (Where no particular temperature or fluid resistance is required Natural Rubber is the most widely used material and offers the greatest scope of compounds and properties coupled with the most economic cost).

If a rubber meets most of the requirements but is borderline on a particular property, Harboro should be consulted for further advice with a view to testing under the relevant conditions (if necessary).

Harboro can also offer advice and clarification if resistance to specific fluids is required. The company has detailed records and will carry out swell tests with the relevant fluid free of charge to establish a suitable rubber.

When a suitable rubber has been chosen, refer to the more detailed information contained in the Data Chart (pages 16-17) to check the suitability of the rubber for all aspects of the application.

MATERIAL SELECTION CHART

	Natural Rubber	EPDM	Neoprene	Nitrile	CSM	Acrylic	Vamac®	Silicone	Viton®	Flouro Silicone	SBR
Price Grade	1	1	2	2	3	4	4	8	15	40	1
Max Int Temp (°c)	105°c	150°c	125°c	130°c	160°c	180°c	180°c	300°c	300°c	280°c	115°c
Max Cont Temp (°c)	75°c	130°c	95°c	100°c	130°c	150°c	150°c	205°c	205°c	200°c	85°c
Lowest Temp (°c)	-60°c	-50°c	-35°c	-20°c	-25°c	-20°c	-40°c	-60°c -80°c*	-20°c	-60°c	-55°c
Oil Resistant	No	No	Yes	Yes	Yes	Yes	Yes	Yes	Yes	Yes	No
Weather Resistant	No	No	Yes	Yes	Yes	Yes	Yes	Yes	Yes	Yes	No
Hardness Range	30-95°	30-85°	30-90°	40-100°	40-85°	50-85°	45-90°	40-80°	50-95°	40-80°	40-95°

* -80°C can be achieved with special silicones



DEFINING BASIC MECHANICAL PROPERTIES

Hardness

Once a rubber type has been selected, the hardness range must be determined. Hardness is measured in degrees on the Shore "A" or IRHD scale (the values are similar although Shore "A" readings are usually one to three degrees higher than IRHD readings). Hardnesses are normally based on a nominal figure e.g. 50 ±5° or as a hardness range e.g. 50-60°. Materials below 30° are extremely soft and comparable with foams. These are available but must be regarded as a special requirement.

A set of hardness test pieces may be obtained from Harboro on request but the hardness ranges may generally be described as follows:

VERY SOFT	30-40°
SOFT	40-50°
SOFT - MEDIUM	50-60°
MEDIUM	60-70°
FIRM	70-80°
HARD	80-90°
VERY HARD	90-100°

Typical Tensile Strengths

Any specific requirements relating to tensile stress/strain properties should be defined by minimum tensile strength, minimum elongation at break and, where relevant, by modulus (i.e. minimum tensile stress at a given strain). Such limits should be derived by calculation based on the actual requirements of the application, by comparison with known values for similar applications or materials, or by testing a material which has been proved satisfactory by trial or experiment.

TYPICAL TENSILE STRENGTHS

Grade	Natural Rubber	EPDM	Neoprene	Nitrile	CSM	Acrylic	Vamac®	Silicone	Viton®	Flouro Silicone	SBR
High	17MPa	14MPa	17MPa	14MPa	-	-	-	-	-	-	14MPa
Medium	14MPa	10MPa	14MPa	10MPa	14MPa	10MPa	10MPa	7MPa	14MPa	7MPa	10MPa
Economy	10MPa	7MPa	10MPa	7MPa	-	-	-	-	-	-	7MPa

Compression Set

Many uses of rubber are compression applications and it may be necessary to define the maximum compression set taken on by a rubber when under load for a period of time. This is usually expressed as the percentage of the compression which is not recovered within a short time after release (30 minutes in BS 903 pt.A6).

Compression set limits should only be specified when necessary and must give the time and temperature as well as the amount of compression to be applied. Typical compression set values are shown below for 24 hours compression at 70°C. The test pieces were compressed to 75% of their original height.

Typical Compression Set Values (24 hours @ 70°C)

TYPICAL COMPRESSION SET VALUES

(24 hrs @ 70°C)

	Natural Rubber	EPDM	Neoprene	Nitrile	CSM	Acrylic	Vamac®	Silicone	Viton®	Flouro Silicone	SBR
Typical Value	25%	25%	35%	25%	40%	20%	30%	15%	35%	15%	25%
Tight Value	15%	15%	20%	15%	20%	10%	15%	7%	15%	7%	15%



DATA CHART

Common Name	Natural Rubber	SBR	EPDM	Neoprene	TOSO-CSM® (Hypalon®)	Nitrile
Chemical Name	Polyisoprene	Styrene Butadiene Rubber	Ethylene Propylene Diene Monomer Rubber	Polychloroprene Rubber	Chlorosulphonated Polyethylene Rubber	Nitrile Butadiene Rubber
Nomenclature	NR	SBR	EPDM	CR	CSM	NBR
Cost Factor	1	1	1	2	3	2
Hardness Range	30-95°c	40-95°c	30-85°c	30-90°c	40-85°c	40-100°c
Colours	Full Range	Full Range	Limited Range	Full Range	Full Range	Limited Range
Heat Resistance (°c) Maximum Continuous Maximum Intermittent	75°c 105°c	85°c 115°c	130°c 150°c	95°c 125°c	130°c 160°c	100°c 130°c
Low Temperature Resistance	-60°c	-55°c	-50°c	-40°c	-25°c	-20°c
Resistances Oxidation Ozone & Weathering	Fair Poor	Fair Poor	Excellent Outstanding	Very Good Very Good	Excellent Outstanding	Good Fair
Oil Resistance *ASTM Oil No. 1 @ 20°c @ 100°c	Poor Unsatisfactory	Poor Unsatisfactory	Fair Unsatisfactory	Excellent Good	Excellent Good	Excellent Good
*ASTM Oil No. 3 @ 20°c @ 100°c	Unsatisfactory Unsatisfactory	Unsatisfactory Unsatisfactory	Unsatisfactory Unsatisfactory	Good Fair	Excellent Fair	Excellent Good
Fuel Resistance *ASTM Fuel B @ 40°c	Unsatisfactory	Unsatisfactory	Unsatisfactory	Poor	Poor	Fair
Solvent Resistance (20°c) Alcohol Acetone Benzene	Good Fair Unsatisfactory	Good Fair Unsatisfactory	Good Good Unsatisfactory	Good Fair Unsatisfactory	Good Fair Unsatisfactory	Good Unsatisfactory Unsatisfactory
Chemical Resistance Acids Bases	Fair Good	Fair Good	Good Good	Good Fair	Very Good Good	Good Fair
Physical Strength	Excellent	Good	Good	Good	Good	Good
Compression Set	Good	Good	Good	Fair to Good	Fair	Good
Tear & Abrasion Resistance	Excellent	Good	Good	Good	Good	Good
Resilience	Excellent	Good	Very Good	Very Good	Fair	Good
Permeability to Gases	Poor	Fairly Low	Fairly Low	Low	Low	Low
Electrical Strength	Excellent	Excellent	Excellent	Good	Good	Poor
Flame Resistance	Poor	Poor	Poor	Self-extinguishing	Good	Poor
Water Resistance	Very Good	Good	Excellent	Good	Very Good	Good

The aromatic content of oils has a moderate swelling effect on rubber. ASTM Oil No.1 (Flash point 243°c, Aniline point 124°c) has a swelling effect. ASTM Oil No.3 (Flash point 163°c, Aniline point 70°c) has a severe swelling effect. Both oils are petroleum based and are fully described in ASTM D471.

Acrylic	Vamac®	Epichlorohydrin	Butyl	Silicone	HNBR	Viton®	Fluorosilicone
Polyacrylic Rubber	Ethylene Acrylic Rubber	Epichlorohydrin Rubber	Polyisobutylene Rubber	Polysiloxane	Hydrogenated Nitrile Rubber	Fluorocarbon Rubber	Fluorosilicone Rubber
ACM	AEM	ECO	IIR	Si	HNBR	FPM	FSi
4	4	4	4	6	8	15	40
50-85°c	45-90°c	40-85°c	40-85°c	40-80°c	50-95°c	50-95°c	40-80°c
Black	Limited Range	Limited Range	Limited Range	Full Range	Limited Range	Limited Range	Limited Range
150°c 180°c	150°c 180°c	140°c 160°c	120°c 135°c	205°c 300°c	125°c 160°c	205°c 300°c	180°c 200°c
-20°c	-40°c	-30°c	-50°c	-60°c (special grades -80°c)	-30°c	-20°c	-60°c
Excellent Excellent	Excellent Excellent	Excellent Good	Very Good Very Good	Excellent Outstanding	Excellent Very Good	Outstanding Outstanding	Excellent Outstanding
20°c Excellent 100°c Excellent 150°c Good	20°c Excellent 100°c Excellent 125°c Excellent	Excellent 150°c Good	Fair Unsatisfactory	Excellent Good	Excellent Excellent	Excellent 150°c Excellent	Excellent 150°c Excellent
20°c Excellent 100°c Good 150°c Fair	20°c Excellent 100°c Fair 125°c Poor	Excellent 150°c Good	Unsatisfactory Unsatisfactory	Good Fair	Fair Fair	Excellent 150°c Excellent	Excellent 150°c Excellent
Poor	Unsuitable	Good	Unsatisfactory	Unsuitable	Good	Excellent	Fair (good at low temps)
Good Unsatisfactory Unsatisfactory	Fair Fair Unsatisfactory	Fair Unsuitable Unsuitable	Good Excellent Unsuitable	Good Fair Unsatisfactory	Excellent Good Fair	Good Unsuitable Good	Good Unsuitable Good
Poor Poor	Fair Good	Poor Fair	Good Good	Fair Fair	Good Good	Excellent Good	Good Fair
Good	Good	Good	Good	Poor	Good	Good	Poor
Good	Fair	Good	Fair to Good	Good	Good	Good	Good
Good	Good	Fair	Fair to Good	Poor	Very Good	Good	Poor
Poor	Fair	Fair	Low	Good	Fair	Fair	Fair
Low	Very Low	Low	Low	Fairly Low	Low	Very Low	Fairly Low
Fair	Good	Poor	Good	Excellent	Poor	Good	Excellent
Poor	Fair	Good	Poor	Good	Poor	Self-extinguishing	Self-extinguishing
Poor	Good	Fair	Excellent	Good	Very Good	Good	Good

Vamac®, Viton® and Hypalon® are registered trade marks of Du Pont Performance Elastomers. TOSO-CSM® is a registered trade mark of TOSOH Corporation (Hypalon® now withdrawn).

SPECIFYING RUBBER

DEFINING OTHER MECHANICAL PROPERTIES

Additional mechanical requirements should be specified only where necessary. They can be specified simply by description e.g. "good tear resistance required" or quantified by the use of a defined test method (such as ASTM or BS test methods) giving maximum or minimum values as appropriate. These values may be obtained by calculation based on the actual requirements of the application, by comparison with known values for similar applications or materials, or by testing a material which has been proved satisfactory by trial or experiment.

A list of properties which can be tested and defined by the use of the appropriate British Standard and ASTM tests.

Where requirements are considerably more complex than the scope of this publication, the ASTM or BS framework for specifying rubber materials (see below) can be consulted. Materials may also be selected from the BS range of standard and special application specifications, some of which are listed on the opposite page.

If the properties required of the rubber are difficult to determine, the production of a prototype mould should be considered. A variety of rubber compounds can then be moulded and parts tested for suitability in the actual application. Once a material has been proved suitable, it can be tested and its properties appropriately defined.

DEFINING ELECTRICAL PROPERTIES

Rubber is often used as an electrically insulating material and, correctly formulated, it can offer outstanding properties in this respect. However, electrical properties are dependent on the materials used in compounding and requirements should be clearly defined.

In general, an insulating material can be defined as having an electrical resistance greater than 100 megohms per cm³. Materials for applications requiring extremely good insulating properties are usually defined by electric strength, measured in Kilovolts (KV) per mm thickness of material. This is calculated by placing a sheet of the material between two electrodes and applying an increasing voltage until electrical breakdown occurs.

Good insulation is achieved by the use of non-black fillers and compounds of any colour which are based on these fillers are suitable for insulation purposes.

For test methods and recommended resistance values for anti-static and conductive rubbers, please see BS 2050.

Types of Rubber / Resistance

Silver Loaded	Less than 1ohm
Conductive	Less than 10,000 ohms
Anti-static	10 ⁴ - 10 ⁶ ohms
Insulating	Over 10 ⁸ ohms
Highest Insulation	10 ¹⁴ ohms

ASTM & BS FRAMEWORK FOR SPECIFYING RUBBER MATERIALS

A method for specifying rubber materials can be found in ASTM D2000 and BS 5176. These provide a full framework covering all rubbers and rubber properties. The relevant requirements for an application are selected from within the framework and are expressed in the form of a "line call out". (The same framework is used in both ASTM D2000 and BS 5176).

An example of a line call out is BS 5176 1MBC514 F27Z1. This can be broken down as follows:

LINE CALL OUT

1	M	B	C	5	14	F27	Z1
Basic Grade	Metric Figures	Mat'l Type	Mat'l Class	Hardness	Tensile	Low Temp Test	Special Requirements
-	-	Neoprene	Neoprene	50+/-5° IRHD	14MPa Minimum	-40°C Flexibility	e.g. Colour Red

The appropriate table for Grade 1 MBC materials shows the following basic requirements:

Elongation at Break

400% minimum

Heat Resistance (70 hrs @ 100°C)

Tensile strength ± 30%
Elongation at break -50% max
Hardness ±15° max

Oil Resistance (Oil no.3 70 hrs @ 100°C)

Volume change + 120% max

Compression Set (22 hrs @ 100°C)

80% max

F27 is a low temperature modulus test to BS 903 A13.

For Grade 1 MBC materials the requirement is for a modulus of 70MPa at -40°C (i.e. rubber is still flexible at -40°C).

Z1 indicates an additional special requirement. This would be shown on the drawing e.g. Z1 = red colour required.

The following specifications cover rubber materials for general applications:

- BS 1154 Natural Rubber compounds
- BS 2751 Nitrile Rubber compounds
- BS 2752 Chloroprene (Neoprene) Rubber compounds
- BS 3222 Low compression set Nitrile compounds

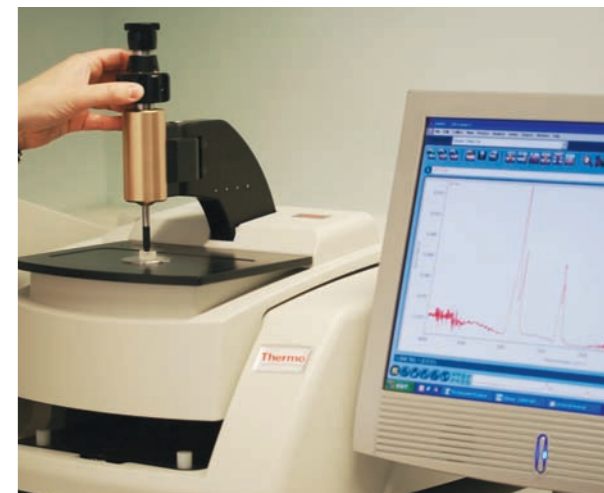
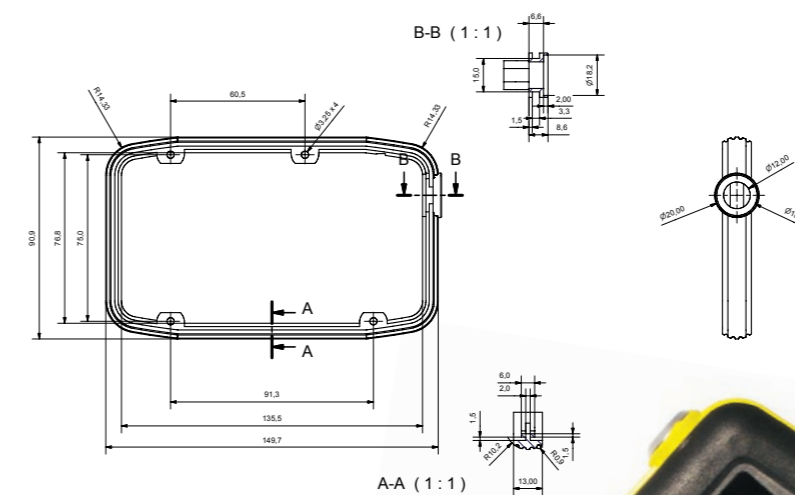

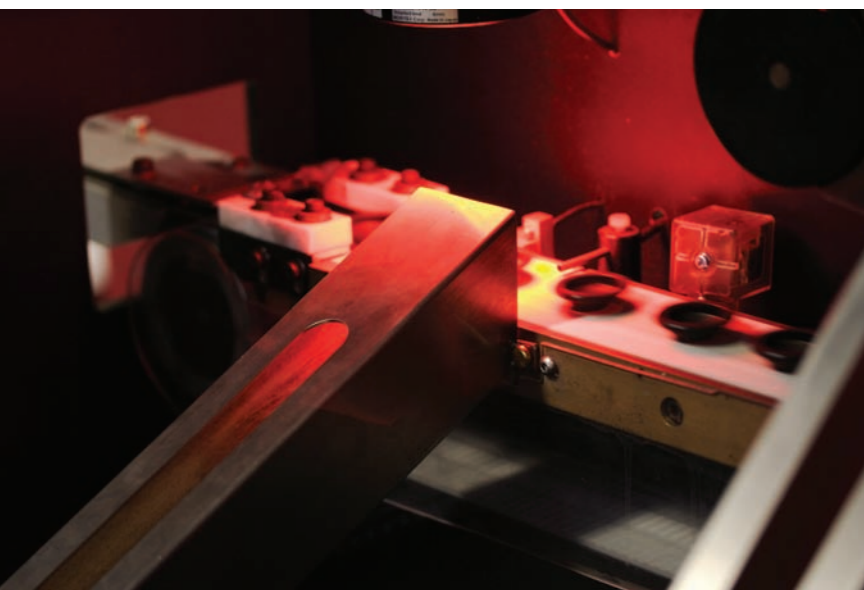

QUALITY IN RUBBER

QUALITY

Quality is often described as “fitness for purpose” but such a definition has no cost or processing considerations. A part produced using poor processes, which can be guaranteed only as the result of inspection, has no inherent quality. A fuller definition is “reliability of function at lowest cost, resulting from good design and the use of capable processes”.

Quality begins on the drawing board. An understanding of rubber properties and processing will lead to the simplest design which maximises function and minimises production problems - in tooling as well as part manufacture. Such parts offer the lowest cost and highest value.

Combining the skills and knowledge of the designer and the rubber engineer at an early stage will enhance those aspects of design which best exploit rubber's potential and prevent future problems. Care should be taken in ensuring that tolerances and other features can be achieved through capable processes. If potentially incapable processes are to be used, design revisions should be considered.

Designs should then be passed through FMEA for confirmation and control and monitoring points generated. The platform for quality is now established.

In most cases, designs should also be validated through prototypes. New tooling should be passed through pre-production trials, capabilities confirmed and initial SPC limits established.

ZERO DEFECTS

The goal of all quality conscious companies is zero defects. This is achieved through the use of capable processes and statistically based monitoring; it cannot be achieved by human visual inspection.

Continual improvement is needed to increase the capability of processes. In today's rubber industry, this capability is relatively low and many aspects are difficult to monitor. For example, rubber is pliable and dimensions such as cylindrical diameters often cannot be gauged quickly and accurately. In preparing blanks, actual volume cannot easily be measured and in moulding, the injection process is often more sensitive to material variation than any existing rheometer.

Rubber materials crosslink and are time and temperature sensitive in mixing, storage and preparation. This results in significant viscosity variations during flow. Friction heat through channels and mould gates (up to 30°C gain) creates differences between material and mould temperatures which cannot easily be measured.

Despite such problems, much progress has been made in recent years through the emphasis on consistent processing and with modern computer-based injection presses which are self-adjusting, within limits, to material variations. This, combined with high levels of operator knowledge and vigilance, makes production at near zero defect levels possible (below 100ppm).

At present, world class levels of internal rejects should not be assumed in rubber but they can be achieved through careful design and adherence to the procedures outlined above. Across the industry, internal reject rates run at a typical but unacceptable level of 2%, but rates of 500 ppm (0.05%) - well within world class levels, (Anderson Report) - can be sustained across a range of parts, materials and machines.

Clearly, any single part with well designed processes can achieve lower ppm reject levels. As more and more parts are designed on the right basis, and continuous improvement is applied to processes, capabilities will rise and reject levels fall. Harbors rubber employ computerised camera inspection where near zero defects are required.

It is important to consider present capabilities. The following is intended to provide a general guide using typical results, but every material, machine and process has its own capability and these can vary considerably.

HARDNESS

Hardness is measured by pressing an indenter into the rubber and measuring penetration. Shore A is based on an immediate reading using a spring applied load. Variation from user to user can be as great as +/-2.5°. IRHD uses a dead load with a 30 second wait and is more consistent, giving user variations of +/-1.5° (3 sigma). There can be significant differences between the two types of readings.



Normal Hardness Capability/Tolerance

Hardness (IRHD)	Capability (+/-3 sigma)	Normal Tolerance
80-100°	+/-2°	+/-5°
70-80°	+/-2.5°	+/-5°
50-70°	+/-4°	+/-5°
40-50°	+/-5°	+/-5°

DIMENSIONS

ISO 3302:1995 (BS 3734) gives a brief background to rubber moulding tolerances. Tighter limits can be achieved (particularly with injection moulding), by slowing the process and moulding under minimum stress conditions. Limiting the number of cavities and shortening the flow path for the rubber also gives improvements, but clearly all these measures have a commercial cost.

Tolerances in rubber are generally less critical as the material deforms readily and accommodates variations. In fact, errors in measuring rubber can be significant and non-contact methods should be used wherever possible.

When designing tooling, critical dimensions should be taken into account to minimise the effects of tool split lines and flow. Stresses built up while the material flows can be moulded in if curing begins before the rubber is relaxed. On removal from the mould the part will distort accordingly, resulting in lower dimensional capabilities.

ISO 3302:1995 (BS 3734) moulding tolerances are given on page 13. M2 tolerances are normal commercial tolerances and can be met by most rubber materials. M1 tolerances can be achieved through careful design and consideration. Production rates may be affected in some instances and good tooling and equipment is required. Particular attention should be given when using high shrinkage materials such as Silicones, Fluoroelastomers and peroxide cured rubbers.

FORCES (keypads)

Keypad force tolerances should not be considered in the same way as dimensional tolerances. Nearly all keypads are finger operated and the finger is relatively insensitive to exact loads. This is particularly true of single finger operation where loads of +/- 30% will not be noticed by a user. Examples include car switches, input devices, phones and instrument controls.

The exceptions are computer and typewriter keyboards where a tolerance of +/- 15% is required. In this case the finger rarely reaches full travel and operators are sensitive to forces because of the high frequency of use.

Capabilities depend upon membrane design and length of travel. Typical capabilities are as follows:

Button Type	Travel Distance	Force Tolerance
Small Key	1-2 mm	+/-30%
Typical Key	2-4 mm	+/-25%
Professional Keyboard	4+ mm	+/-15%

Force variation is greatly affected by the fixing of the keypad base and by the escutcheon/keycap interface with the rubber. It is strongly recommended that early advice is sought.

RUBBER DIRECTORY

NATURAL RUBBER

(Polyisoprene)

The original natural material which has been in commercial use since the turn of the century. The most widely developed rubber with a huge range of compounds available. It also usually has the lowest price.

Natural rubber is an environmentally desirable material and comes from a naturally sustainable source. During its production as a tree sap (latex), it constantly absorbs carbon dioxide (a greenhouse gas) from the air. At the end of their working lives, the rubber trees are used to make furniture and are replaced with young trees for further production. Natural rubber itself is readily biodegradable and non-toxic.

Properties

- widest range of hardnesses
- very strong (naturally self-reinforcing) and extremely resilient
- good compression set
- good resistance to inorganic chemicals

Limitations

- lack of resistance to oil and organic fluids
- relatively low maximum temperatures (75°C continuous, 100°C intermittent)
- poor ozone resistance, with tendency to perish in open air (can be improved to some extent by careful compounding)

Typical Applications

- components which are protected from constant air changes - i.e. inside machinery - and which do not come into contact with any oil or oil based fluids
- applications requiring strength and resistance to abrasion
- sealing and shock absorption

EPDM

(Ethylene Propylene Diene Monomer)

EPDM is widely used because of its suitability for outdoor use. It is low cost polymer which resists water, air ageing and many chemicals and has a wide temperature range. It does not have any oil resistance and care should be taken with its formulation when it is used in direct contact with some plastics.

Properties

- the most water resistant type of rubber - also very resistant to most water based chemicals
- very inert structure, remains stable over long periods of time
- can withstand temperatures of up to 130°C for extended periods of time (months)
- very good weathering resistance
- easily compounded and processed

Limitations

- will not resist oil or oil based products
- compression set not as good as some other rubbers, but can be improved by careful compounding
- formulation needs careful consideration when used in contact with some plastics (e.g. ABS) as some plasticisers move from the EPDM into the plastic and can discolour or swell the plastic

Typical Applications

- general engineering without exposure to oil

NEOPRENE

(Polychloroprene)

One of the first synthetic rubbers developed in the search for oil resistant rubber. Widely used due to its combination of useful properties and comparatively low price.

Properties

- resistant to a wide range of hostile environments
- resistant to oils and chemicals
- weather and water resistant
- can withstand temperatures from -30°C to 95°C
- easy to process and compound, offering cost benefits
- flame retardant
- can be produced in any colour required

Limitations

- unsuitable for applications requiring contact with fuels
- tendency to tear once there is initial damage
- some Neoprenes may crystallise during storage or use causing temporary stiffening (increase in modulus/hardness). If parts are deformed during crystallisation, they may take on a set. However, crystallisation is a readily reversible phenomenon and can be removed by warming over 80°C. It can be prevented by the use of special grades

Typical Applications

- most general mechanical applications without contact with fuel
- particularly useful in marine environments due to good ozone resistance

CSM

(Chlorosulphonated Polyethylene)

Developed in the 1950s as a speciality rubber for rugged applications. Best described as a "super" Neoprene, with similar but better developed characteristics.

Properties

- resistant to oil and fluids, especially at higher temperatures (+125°C)
- extremely resistant to ozone and weathering - can withstand harsh outdoor conditions for up to 15 years

Limitations

- cannot be used where there is contact with fuels
- limited low temperature performance (-25°C)

Typical Applications

- situations where there is likely to be heavy weather conditions or exposure to hot liquids and/or gases

NITRILE

(Acrylonitrilebutadiene)

Another early development in the search for an oil resistant rubber. The most suitable rubber for applications requiring resistance to petroleum based fluids (there are rubbers with higher degrees of resistance but these are much more expensive).

Properties

- very good resistance to petroleum based fluids
- good high temperature resistance - up to 100°C (120°C with EV cure systems)
- economical to compound and produce
- very low level of permeability to gases

Limitations

- poor resistance to outdoor weathering without special compounding
- comparatively low strength
- flammable and burns with toxic fumes

Typical Applications

- sealing in enclosed spaces where there is contact with petroleum based fluids
- sealing against gases

ACRYLIC

(Polyacrylic)

A synthetic rubber which is particularly resistant to hot oil.

Properties

- excellent resistance to oxidation and weathering
- particularly resistant to oil at high temperatures

Limitations

- low temperature applications limited to -20°C
- poor chemical resistance to acids and bases
- very low resilience below 70°C

Typical Applications

- anywhere where resistance to hot oil or fuel is required

VAMAC® *

(Ethylene Acrylic)

Provides good oil resistance over a wide temperature range. More expensive than Nitrile but considerably cheaper than Silicone.

Properties

- good resistance to oxidation and weathering
- good oil resistance
- strong and abrasion resistant

Limitations

- no resistance to fuels

* VAMAC® is a registered trade mark of Du Pont

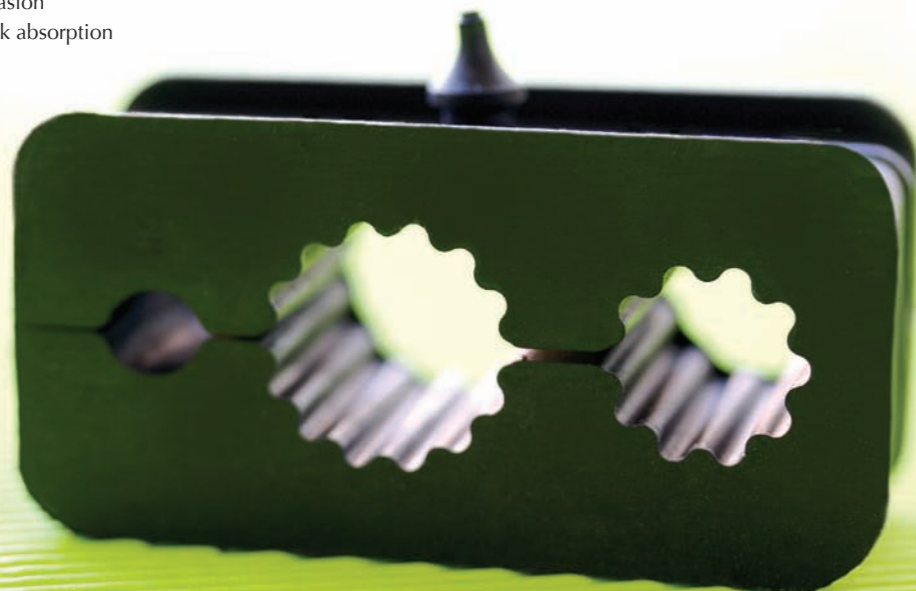

THERMOPLASTIC RUBBERS (TPRs)

e.g. Santoprene® †

A proprietary brand of EPDM and Polypropylene, readily available in a range of hardnesses. Flame retardant and coloured grades can also be obtained.

Properties

- easy to process
- reasonable resistance to fuels and oils
- available in hardnesses ranging from 60° to 99° Shore A

Limitations

- limited maximum usable temperature
Actual maximum temperatures depend upon the properties required - only the softer grades are "elastic". At temperatures over 80°C Santoprene cannot take stress since it softens and creeps, leading to permanent distortion. Other TPRs have even lower softening temperatures. Advice should be sought if the parts are load bearing (significant tension or compression)

Typical Applications

- vast range of flexible parts used at room temperature

† Santoprene® is a registered trademark of Exxon Mobil Corporation.

SILICONE

(Polymethylsiloxane)

Synthetic rubber with a wide temperature range and outstanding resistance to weathering. Characterised by clean, smooth appearance with good flexibility.

Properties

- wide temperature range
- extremely good resistance to weathering
- excellent electrical properties
- good resistance to oils
- easily coloured
- low level of toxicity

Limitations

- not a very strong material
- poor resistance to fuels
- expensive compared to other rubbers

Typical Applications

- anywhere where complete resistance to weather/fluids is required
- electrical applications

FLUOROCARBON (VITON®)*

The best material for resistance to hostile chemical and oil environments at normal and elevated temperatures.

Properties

- strong
- good resistance to water
- good resistance to fuels, oils and most chemicals

Limitations

- limited use at low temperatures, -20°C being the limit for flexibility
- expensive
- does not resist Ketone solvents

Typical Applications

- situations requiring resistance to hostile fluids at high temperatures

* Viton® is a registered trade mark of Du Pont

FLUOROSILICONE

The best rubber to use in hostile environments where fuel, oil, chemicals or low temperatures are encountered.

Properties

- performs excellently in the temperature range -60°C to 200°C
- resistant to oils and fuels (particularly at low temperatures)
- good electrical strength

Limitations

- not physically strong
- very expensive

SBR (STYRENE BUTADIENE RUBBER)

A synthetic rubber which is easy to process in large quantities. Widely used in the footwear and tyre industries.

Properties

- good physical strength
- good tear and abrasion resistance
- range of colours
- one of the cheaper rubbers

Limitations

- does not resist oil or fuels
- prone to weathering

Typical Applications

- non-mechanical high-volume products such as shoe soles and heels or car tyres

SPECIALIST ELASTOMERS

THERBAN® ‡ (HNBR)

Hydrogenated nitrile rubber provides good all round performance at a compound cost between Nitrile and Fluoroelastomer. Its highly saturated main chain provides good resistance against thermal oxidation and chemical attack.

Properties

- good physical properties, including abrasion resistance, at high temperatures
- good dynamic behaviour and flex cracking resistance at elevated temperatures
- excellent heat, ageing and ozone resistance
- outstanding resistance to steam and hot water

Limitations

- no inherent flame retardency
- poor electrical properties
- unsuitable in contacts with aromatic and polar organic solvents

Typical Applications

- diaphragms requiring chemical and heat resistance
- chain tensioners and seals in vehicle engines
- oil exploration and production

‡ Therban® is a registered trademark of Lanxess Deutschland GmbH.

EPICHLOROHYDRIN

A synthetic rubber designed for more extreme heat and oil resistance applications. Best described as a "super" Nitrile.

Properties

- very good high temperature resistance, up to 150°C
- good low temperature properties
- good ozone resistance

Limitations

- expensive
- may require higher cost tooling
- relatively low physical strength

Typical Applications

- automotive applications such as fuel systems
- printing rollers

LIQUID SILICONE

An addition cured Silicone which is processed in modified plastic injection moulding presses. Liquid Silicone is similar in properties to normal Silicone but varies in its processing characteristics. It is purchased as a two part raw material with a viscosity similar to Vaseline. The two materials are pumped from a drum through a mixing head and injected into the cavities. Very low pressures are involved and very fast cures (typically 20-45 seconds).

Properties

- Similar to those of normal Silicone rubber, plus:
- full range of hardnesses can be achieved
- extremely clean process enabling colour matching
- fast cycles and low material usage offers significant cost advantages on long runs

Limitations

- lower strength, particularly where harder grades are used
- tooling is very expensive (up to 10x normal rubber tool cost) due to low viscosity and the need to remove air and prevent flash
- short runs are not viable due to the difficulties of setting up. Liquid silicone should only be considered for long runs, particularly where the weight to part size ratio is low

Typical Applications

- baby bottle teats
- thin diaphragms
- syringe plungers



Accelerators

Chemicals which are added to rubbers to accelerate the rate of vulcanisation. Rubber without accelerators takes twenty or thirty times longer to cure.

Acid acceptors

Mostly used in neoprenes to absorb the acid produced by the chemical reactions which take place during curing. Acid acceptors are usually metal oxides.

Activators

Chemicals which are added to rubbers to activate curing.

Backrinding

A “breaking up” of the rubber normally observed around tool split lines. It results from the rubber shrinking during cure and tearing away at points where the moulding is held.

Banbury Mixer

An internal mixer commonly used in the rubber industry. It consists of two shaped rotors which turn inside a sealed chamber.

Bleeding

The exudation of droplets of excess plasticiser onto the surface of the rubber. This happens when rubbers contain unsuitable levels of plasticisers which are not fully compatible.

Bloom

A white or light coloured crystalline deposit on the surface of the rubber. Many chemicals added to rubber have a limited solubility. If they are present in a cured rubber at levels higher than their solubility, they crystallise out onto the surface.

Building Tack

Term used to describe the ability of a rubber to stick to itself in the uncured state, so allowing pre-building of the material before curing.

Calendering

Producing rubber in continuous sheets by processing it through a series of rollers. Harboro does not specialise in this sector of the industry.

Clay

Commonly used as an “extender” in rubber. Treated clays reinforce the rubber and are termed “hard” clays. Those which do not provide reinforcement are called “soft” clays.

Compound

A general word used to describe a particular formulation or “recipe”, or as a descriptive term for unvulcanised rubber in general. It is used in such applications as “compounding ingredients”, “compound no. Xyz”, etc.

Compression Set

The degree to which a rubber does not recover fully to its original state after it has been compressed for a long period of time. (See also “measurement of rubber properties” on pages 28-29).

Crystallisation

Rubber materials tend to crystallise on standing, resulting in an increase in hardness. This increase is usually small, but can be more significant in the case of some neoprenes (polychloroprenes).

Curatives

The chemicals involved in curing the rubber, e.g. Accelerators, vulcanising agents, activators etc.

Curing

Also known as vulcanisation, this is the permanent change which the rubber undergoes during moulding. When mixed, rubber compounds are thermoplastic and will melt and deform easily. After curing, the rubber is heat stable.

Elastomer

General term used to describe all natural and synthetic polymeric materials which have rubbery or “elastic” properties.

Electric Strength

Describes the ability of a rubber to withstand high voltages. It is usually quoted in kv per mm of rubber thickness. (See also “measurement of rubber properties” on pages 28-29).

Extrusion

Producing continuous lengths of rubber with a constant profile by forcing it through a die under pressure and vulcanising it.

Fillers

General term describing the bulk materials which are added to the rubber (usually as powders).

Flash

Excess rubber found on mouldings as a result of the moulding process, but which does not form a part of the moulding itself. This does not usually include feed gates but refers particularly to thin films of rubber formed at tool split lines etc.

Flex Cracking

The tendency of some materials to crack as a result of repeated bending or stressing at the same point.

Formulation

The term used to describe a rubber “recipe”.

Heat

(see “lift”)

Heat Ageing

Also known as “accelerated ageing”. Rubber materials are often tested for shorter times at higher temperatures to predict what will happen over longer times and at lower temperatures.

Hysteresis

The difference between the amount of energy absorbed when a rubber is stretched and the amount of energy released when the rubber is relaxed. High hysteresis indicates a high loss of energy (and so is good for energy absorbing applications). Low hysteresis rubbers are more resilient.

Lift

The set of rubbers resulting from a single mould cycle or pressing. Also called a “heat”.

Modulus

The relationship between stress (force) and strain (extended length). Modulus is usually given as the stress (or force) required to extend a rubber (e.g. 100%, 200% Extended).

Plasticisers

Liquids which are incorporated into rubber, generally described as plasticisers because of their softening effect.

Polymer

General term used to describe all rubbers and plastics. In fact, it is the chemical term used to describe all organic materials which are formed from chains of repeated chemical units.

Resilience

The technical term used to describe “bounce” or “snap”. Increasing resilience means an increasing “bounciness”.

Scorch

The onset of cure, when chemical reactions begin to take place in the rubber as it is being heated. A “scorched” rubber is no longer processable.

Set

The degree to which a rubber does not fully recover to its original shape after it has been deformed for a long period of time. Also called “permanent set”.

Strain

The change in length of a rubber under tension or compression. A rubber stretched to double its original length would be at 100% strain.

Stress

An applied force or load. A load of 1kg applied to a test piece would be a stress of 1kgf.

Thermoplastic

Any material which melts on heating and resets on cooling. This melting and refreezing can be repeated indefinitely.

Thermoset

Any material which melts on heating but then undergoes a permanent chemical change after which it is heat stable (i.e. it will degrade on further heating rather than “melt”).

Undercure

Removing rubber from the mould before the vulcanisation process has been completed. Often results in porosity in the rubber or unusually poor compression set.

Vulcanisation

The permanent chemical change that a rubber undergoes on heating together with chemicals. The chemicals which accomplish this change are called “vulcanising agents” and crosslink the molecular rubber chains.

MEASUREMENT OF RUBBER PROPERTIES

Property	Method of Measurement	ASTM Reference	BS Reference	ISO Reference	DIN Reference
Rubber	Elastomeric (i.e. rubbery or resilient) thermoset.	-	-	-	-
Hardness	Measured in degrees and based on the penetration into the rubber of a defined indenter under a set load. Three scales are commonly used: IRHD (International Rubber Hardness Degrees), Shore A, and Shore D for hard materials over 90° Shore A. IRHD is preferred for most specifications but Shore A is also in widespread use.	D2240 D1415	BS 903 Part A26 BS 903 Part A57	ISO 48 ISO 1400 ISO 1818	DIN 53505
Tensile Strength	This is measured in various units and is expressed as a force per unit area. A standard dumbbell type test piece of known cross sectional area is used which is stretched until it breaks. The force required to do so is then recorded and expressed as force per unit area.	D412	BS 903 Part A2	ISO 37	DIN 53504
Elongation	Elongation is defined as the length at breaking point expressed as a percentage of its original length (i.e. length at rest) e.g. if a rubber reaches twice its length before breaking its elongation is 100%.	D412	BS 903 Part A2	ISO 37	DIN 53504
Modulus	Modulus is measured as the force per unit area required to extend a rubber to a stated percentage of its original length e.g. to 100%, 200% or 300%. It is often written as M100=3.0MPa (i.e. modulus at 100% =3.0MPa).	D412	BS 903 Part A2	ISO 37	DIN 53504
Compression Set	A cylindrical button of rubber of known thickness is compressed to a fixed height (typically 70% or 75% of its original height) at a defined temperature for a specified period of time. The button is then released, allowed to recover (typically for 30 mins) and the thickness is measured. Compression Set is the height that is not recovered expressed as a percentage of the amount by which it was compressed. % Comp. Set = $\frac{\text{original height} - \text{recovered height}}{\text{original height} - \text{compressed height}} \times 100$	D395	BS 903 Part A6	ISO 815	DIN ISO 815
Permanent Set (Tensile Set)	A standard test piece of known length is stretched by a stated percentage for a period of time and is then released. After recovery the length is measured and the change in length (i.e. unrecovered length) is expressed as a percentage of the extended length.	D412	BS 903 Part A5	ISO 2285	DIN ISO 2285
Density (Specific Gravity)	Density is defined as the mass per unit volume and is measured by weighing the rubber sample in air and water. S.G = $\frac{\text{weight in air}}{\text{weight in air} - \text{weight in water}}$	D297	BS 903 Part A1	ISO 2781	-
Resilience	Resilience is measured on standard test equipment (of which there are several types - e.g. Dunlop, Tripsometer, Lupke, Rebound). Standard test pieces are struck by the 'hammer' and the 'bounce back' of the hammer measured. This is expressed as a percentage of the flight path of the hammer.	D1054 D2632 D945	BS 903 Part A8	ISO 4662	DIN 53512
Chemical Resistance	This is usually expressed as the change in properties (such as hardness, strength and elongation at break) caused by the presence of chemicals under defined conditions (including concentration, time and temperature).	-	-	-	-
Fluid Resistance	Fluid resistance is commonly measured by the effect of the fluid on the volume of the rubber expressed as a volume change (e.g. +100% indicates that the volume of the rubber has doubled as a result of exposure to the fluid, -10% indicates that the volume of rubber had decreased as a result of exposure to the fluid). Volume change is measured by determining the weight of a sample in air and water before and after exposure to the fluid under defined conditions. The sample is normally totally immersed in the fluid. Volume Change (%) = $\frac{(W3 - W4) - (W1 - W2)}{(W1 - W2)} \times 100$ Fluid resistance may also be defined in the same way as chemical resistance (above) i.e. by change in properties of the rubber. W ₁ Wt in air (initial) W ₂ Wt in water (initial) W ₃ Wt in air (swollen) W ₄ Wt in water (swollen)	D471	BS 903 Part A16	ISO 1817	DIN ISO 1817
Weather Resistance	Weather resistance is a fairly subjective test and it is necessary to state clearly the conditions under which the exposure took place i.e. dates, geographic location, angle and direction of exposure relative to the sun etc. The properties of test pieces are measured before and after exposure and expressed as percentage changes (with the exception of hardness changes which are usually recorded in degrees). The change in any property may be measured but the most common are hardness, tensile strength, elongation at break and modulus at 100% and 300%.	D1171 D750 D518 D1148a	BS 903 Part A53 BS 903 Part A54 BS 903 Part A55	ISO 4665-1, 2 & 3	-
Ozone Resistance	Ozone causes cracking in rubber. Test pieces are usually placed under a small degree of tension e.g. by bending round a mandrel or stretching by 5%. The sample is exposed under static conditions to a controlled atmosphere containing ozone (typically 50pphm). The cracks are graded by standard photographs, by measurements or by description, e.g. 'visible under 10x magnification' 'visible to the unaided eye' etc. Results may be recorded as the time taken to reach a particular grade of cracking, or by the grade of cracking apparent after a fixed period of time.	D1149	BS 903 Part A43 BS 903 Part A44 BS 903 Part A45	ISO 1431/1 & 2	DIN 53509

Property	Method of Measurement	ASTM Reference	BS Reference	ISO Reference	DIN Reference
Electrical Properties	Anti-static and conductive properties of rubbers are defined by measuring their electrical resistance. Typical measurements are obtained through the thickness of a sample by using 25mm sq electrodes, under a pressure of 45N and applying a voltage of 500V DC @ approx 6mA. (Energy dissipated into the test piece if limited to 3W max). The surfaces should be cleaned before measuring. Patterned surfaces should be wetted with a conductive solution paint. Results should be recorded in Ω, defining the conditions of testing.	D991 D257	BS 2050 BS 2044	-	-
Tear Strength	Tear strength is measured as the force required to tear a standard test piece. The standard test pieces are designed to produce weak points where a tear is initiated.	D624	BS 903 Part A3	ISO 34-1 & 2	DIN 53506
Abrasion Resistance	Abrasion properties of rubber are difficult to define. Many different abrasion machines have been designed but they do not always give similar results. The most common abraders are AKRON, Dunlop and DIN. Results are recorded as volume loss per standard test piece, or as the difference in volume loss when compared with a standard material of known abrasion value. Indices of relative abrasion are also used.	D1630 D5963 D2228	BS 903 Part A9	ISO 4649	DIN ISO 4649
Electric Strength	Electric strength is measured by placing a disc of rubber of known thickness between two electrodes gradually or stepwise until electrical breakdown occurs. It is expressed in Volts per unit thickness (e.g. KV per mm).	D149	BS 903 Part C2 BS 903 Part C4	-	-
Flame Resistance	Flame resistance testing requires a standard burner and fuel which gives a flame of known characteristics. Rubber samples are then placed at a certain position in the flame and removed after an ignition period. The time taken for the rubber to self-extinguish is recorded with notes regarding afterglow and any hot particles emitted by the sample at any stage.	-	BS 2782	-	-
Low Temperature	A variety of methods are used for determining the low temperature characteristics of rubber. These fall into two groups - (a) measuring brittleness at low temperatures by impact test and (b) measuring the modulus at low temperatures. Different test rigs are required for each method, as described in the relevant specifications. ASTM D2137 measures brittleness. ASTM D1053 and BS 903 Pt A13 measure the modulus characteristics. Two simple tests are a 'bend' test and a 'retraction' test. In the bend test, a sample 25mm wide x 100mm long is bent around a mandrel which is usually of a diameter 10 x the thickness of the test piece (typically 25mm dia.). If the sample bends without cracking it is deemed to be 'flexible at this temperature'. In the 'retraction' test, the sample is stretched and frozen in this position below its glass transition temperature (i.e. the temperature at which the rubber becomes rigid). The temperature is then raised gradually or in steps and the temperature at which the rubber retracts is recorded. It should be noted that rubber passes from a rubber phase into a 'leathery' phase and then into its 'glassy' phase as it is cooled. Different methods can therefore give rise to different values according to their sensitivity to this 'leathery' phase.	D2137 D1053 D1329	BS 903 Part A13 BS 903 Part A25 BS 903 Part A29 BS 903 Part A63	ISO 812 ISO 2921 ISO 1422 ISO 3387	DIN 53545
Staining	The staining of organic finishes of measured by placing a sample of the rubber against a clean sample of the organic finish and applying pressure for a period of time at a given temperature. The sample is then removed and the organic finish examined for evidence of staining or discolouration. Results are recorded as staining or non-staining. It is normal to give a description of any staining that is observed.	D925	BS 903 Part A33	ISO 3865	-
Accelerated Ageing	Heat ageing is widely used as a method of evaluating long term ageing properties. Hardness and dumbbell type tensile pieces are placed in an air circulating oven for a specific period of time at a given temperature (e.g. 7 days at 70°C). The properties of the rubber are then tested and compared with the properties before ageing. The percentage retained for each property is recorded (change in hardness is recorded in degrees).	D573	BS 903 Part A19	ISO 188	DIN 53508
Fatigue	Flex cracking and crack growth test.	-	BS 903 Part A10 BS 903 Part A11 BS 903 Part A49 BS 903 Part A50	ISO 132	-
Creep	Measurement of creep in compression or shear.	-	BS 903 Part A15	ISO 8013	-
Stress Relaxation	Measurement of stress relaxation at ambient or elevated temperatures.	-	BS 903 Part A42	ISO 3384	-
Frictional Properties	Determining frictional properties.	-	BS 903 Part A61	ISO 15113	-
Bond Strength	Measuring adhesion to a rigid substrate.	-	BS 903 Part A21	ISO 813	-
Permeability	Measuring the permeability of rubber to gases.	-	BS 903 Part A7 BS 903 Part A30	ISO 2782	-

MATERIAL DATA

Chemical Name: Rubber or Elastomer

Chemical Family: Hydrocarbons or Silicones

Formula: Rubber with Inorganic and Organic Fillers

Melting/Boiling Point: None (thermoset material)

Volatiles: None

Density: 1.0 to 2.0

Appearance: Black or coloured solid elastomer

FIRE & EXPLOSION HAZARD

Explosive Hazard: Rubber dust is readily ignited and can burn fiercely or explode. Spontaneous combustion can occur, so rubber crumb should be kept in small quantities until cool.

Dust extraction systems should be regularly cleaned to avoid the risk of fire.

Fire Fighting Procedure: Rubber burns exothermically and produces fumes, some of which are toxic. The area should be evacuated. Respiratory protection should be worn when fire fighting.

Extinguishing Media: Usual standard types

HEALTH HAZARD DATA

Result of Exposure: None

Ingestion: Consult a Doctor. Only specially formulated rubber is suitable for oral or food contact. Materials intended for such use require special clearance.

Skin: Possible allergic reaction

Inhalation: Inhalation of rubber dust or fumes should be avoided.

COMPANY STATEMENT

The Harboro Rubber Company Limited manufactures parts to the specifications and drawings supplied by clients. It is a Condition of Sale that customers assure themselves that the parts supplied are safe in use and have been tested under actual conditions of use. It is the direct responsibility of the customer to make the final user or users aware of the conditions for safe use of any product incorporating parts made from rubber.

GENERAL GUIDELINES

These guidelines are intended to draw the attention of designers and users of rubber parts to some of the material's specific properties and behaviour. They should be read in conjunction with the national and international standards and legislation relating to the properties and safe application of rubber.

Storage

Parts made of rubber may deteriorate in storage, therefore before assembly or when not in use they should be stored in a cool, dark environment with minimum air changes. Rubber parts should not be contaminated by oils or other harmful substances, nor be subjected to excessive forces which may permanently deform them.

Crystallisation

Some rubbers partially crystallise at room or lower temperatures. This will change their hardness and flexibility. Neoprene in particular crystallises significantly unless special resistant grades are used.

Crystallisation can generally be removed by heating to 100°C for 30 minutes.

Low Temperatures

All elastomers become stiffer and less rubbery at low temperatures. This may impair their function, for example, a seal may not work if the rubber becomes less flexible. Generally properties are completely regained as the temperature rises.

Designers must ensure that their products are safe if low temperature storage or operation is possible. Special formulations are available to suit these conditions.

High Temperatures

Rubbers deteriorate as their temperature is raised. Each compound has a maximum safe continuous working temperature which depends upon the formulation, service conditions and level of properties required. This temperature may sometimes be exceeded for short periods if some deterioration of the properties can be safely allowed.

Rapid bending or stretching of rubber parts may also lead to a damaging build-up of heat (hysteresis) within the part - for example, a flat tyre.

Rubber which has been overheated will have severely reduced properties and parts may be unable to function as designed. It can also produce unpleasant or dangerous substances, depending upon the base rubber and additives used in the compound.

The typical temperatures for continuous and intermittent duty listed in "Engineering in Rubber" are based on simple laboratory air ageing tests. The only way to ensure totally satisfactory operation is to test the actual rubber compounds under normal (and abnormal) conditions of use.

Burning

Most rubbers are based on hydrocarbons and will burn. Self-extinguishing properties can be obtained by appropriate compounding.

Burning rubber produces great heat and acrid smoke which may contain harmful constituents, including halogens. Fire fighters should be specifically trained to deal with the hazard.

Rubber Dust

Finely divided rubber, such as that produced by grinding or buffing, should be removed safely from the working area. Rubber dust is readily ignited and can burn fiercely or explode. Spontaneous combustion can occur and rubber crumb or dust should be kept in small quantities until cool.

Dust extraction systems should also be regularly cleaned to avoid the risk of fire.

Serviceability

Many rubbers exhibit surface cracking and other forms of deterioration in use, especially in the presence of ozone. Cracking or hardening of the surface of a rubber component may render it likely to fail. Users must inspect rubber parts for signs of deterioration at suitable intervals for the needs of the application. Any parts showing such signs should be replaced immediately.

Properties can also be affected by oils, fluids and gases which may cause volume changes.

Resistance to Chemicals, Oils & Fluids

No rubber resists all chemicals. Compounds must be selected to perform in specific environments and may be affected or damaged by exposure to chemicals, oils or fluids. Designers should therefore specify all likely and possible contaminants and carry out tests to ensure that the finished parts function safely.

Bonded Rubber Parts

The exposure of bonded parts to harmful substances and high or low temperatures may cause failure. Components should be inspected for bond integrity as often as required by the application. Metal parts should be checked for corrosion which may destroy the bond.

Friction

Friction properties will vary widely depending upon the surfaces involved and the presence of oils, water and other substances.

Electrical Properties

Rubbers can be manufactured to be highly insulative or conductive. Designers and users should be aware of these properties and ensure that appropriate materials are specified and tested in use.

It must not be assumed that black rubber compounds have insulating properties, since conductive carbon black is a common reinforcing ingredient.

Radiation

When exposed to ionising radiation, rubbers will undergo increased cross-linking and become harder and less elastic.

In today's fast changing markets, companies need a competitive edge more than ever in order to thrive. The key to prosperity lies in bringing well designed, highly reliable products to the market more quickly than the competition.

To achieve this, companies must work closely with their suppliers, drawing on their expertise to achieve the most cost-effective, easily manufactured designs. They must make use of the most up-to-date technology. They must take advice on the most suitable materials, on maximising component functions to get the best cost/performance ratio and on building in quality to achieve reliable, low cost manufacture. They must have support to prototype and test designs and get finished parts into production as quickly as possible.

At Harboro, our main aim is to support you in such ventures. Our success lies in your success - we have no products of our own to rely on.

But this is only the start of partnership. Throughout a product's life there must be regular reviews to reduce costs and to improve future designs. Small modifications can often produce further savings in both the manufacture of the component and on customers' assembly lines. Reviews should look closely at manufacturing data to seek areas where costs can be reduced, production simplified and quality and reliability increased.

Internally, Harboro makes great use of multi-disciplined teams and welcomes contact with others. This can generate new and valuable ideas.

Partnership is two sided. Both partners need to understand each other's needs and aspirations. Relationships must be built which instill confidence and trust in both sides and both must see their future in the relationship. Harboro operates an open book policy with these partners.

It is our aim to seek and develop such partners.

