

# P

## UGELLI A FESSURE VERTICALI FILTER NOZZLES WITH VERTICAL SLOTS



- Adatto per filtrazione a sabbia, antracite
- Di facile pulizia mediante controlavaggio
- Gamma completa di filetti e codoli
- Economico

- Good for sand and anthracite filters
- Easily cleaned by backwash
- Complete set of thread and stem
- Inexpensive

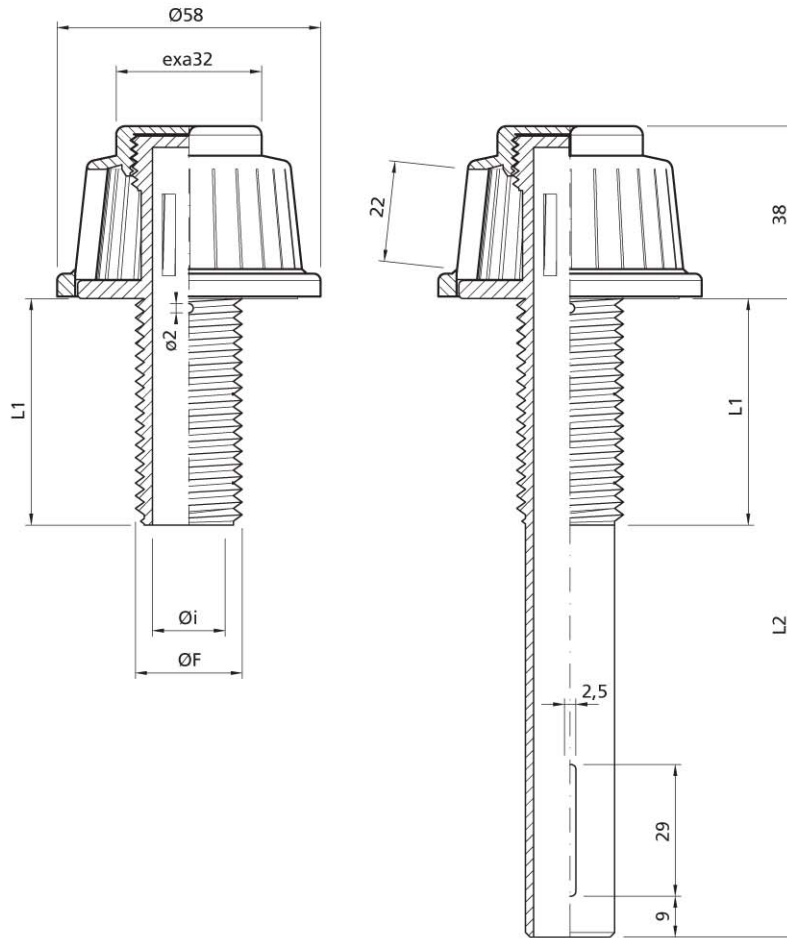

Tipo Type	Fessura Slot width mm	N. Fessure Slots No.	Sezione Area mm <sup>2</sup>
<b>P</b>	0,25	30	165
	0,5	26	286
	1	20	440
	2	18	774
	3	12	684

Materiale/Material: PP - PPFV - PVDF

Filetto Thread	ØF mm	Øi mm	Area codolo Stem area mm <sup>2</sup>	L1 mm	L2 mm
1/2"G	20.9	14,5	165	20, 50	50, 140
3/4"G	26.4	16	200	20, 30, 50	50, 80, 100, 120, 140, 160, 200, ..., 400
M20	20	14,5	165	20, 50	50, 140
M24	24	16	200	20, 30, 50	50, 80, 100, 120, 140, 160, 200, ..., 400
M30	30	16	200	30, 50	50, 160, 200, 250, 280
15/16"W	23.5	16	200	20, 30, 50, 120	50, 80, 100, 120, 140, 160, 200, ..., 400
1"W	25.4	16	200	20, 30, 50	50, 80, 100, 120, 140, 160, 200, ..., 400
1.1/4"W	31.75	21,5	363	30, 50, 65	50, 160, 200, 250, 280, 300, ..., 450

m.c.a. m.W.c. Curva dP/Pressure Loss: P-0,25-W-L50/50

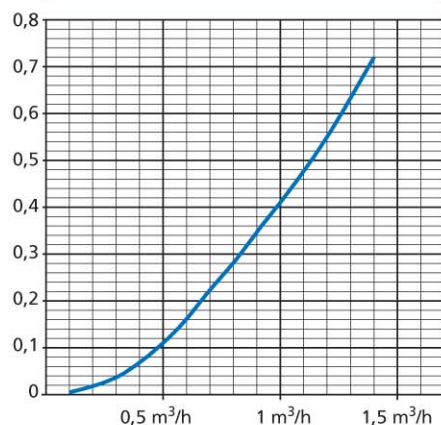

m.c.a. m.W.c. Curva dP/Pressure Loss: P-0,5-W-L50/50

