

## Bluebird Fixings Limited

Westminster Industrial Estate  
Station Road  
North Hykeham  
Lincoln LN6 3QY

Tel: 01522 697776 Fax: 01522 697771  
e-mail: [info@bluebird-fixings.ltd.uk](mailto:info@bluebird-fixings.ltd.uk)  
website: [www.bluebird-fixings.ltd.uk](http://www.bluebird-fixings.ltd.uk)



Agrément Certificate  
**93/2878**  
Product Sheet 1

### BLUEBIRD FIXINGS

### BLUEBIRD SCREW TIE WALL CONNECTORS

This Agrément Certificate Product Sheet<sup>(1)</sup> relates to Bluebird Screw Tie Wall Connectors, comprising stainless or galvanized steel fixings and nylon wall plug for tying new masonry walls to existing walls up to three storeys high.

(1) Hereinafter referred to as 'Certificate'.

#### CERTIFICATION INCLUDES:

- factors relating to compliance with Building Regulations where applicable
- factors relating to additional non-regulatory information where applicable
- independently verified technical specification
- assessment criteria and technical investigations
- design considerations
- installation guidance
- regular surveillance of production
- formal three-yearly review.



#### KEY FACTORS ASSESSED

**Strength** — Provided the existing wall has adequate strength, the product will provide simple lateral support to new masonry wall panels (see section 6).

**Performance in relation to fire** — the product is non-combustible (see section 8).

**Durability** — The product will not be adversely affected by mortars or cavity insulation materials (see section 10).

The BBA has awarded this Agrément Certificate to the company named above for the product described herein. The product has been assessed by the BBA as being fit for its intended use provided it is installed, used and maintained as set out in this Certificate.

On behalf of the British Board of Agrément

Date of First issue: 18 February 2013

Originally certificated on 17 March 1993

Handwritten signature of Brian Chamberlain in black ink.

Brian Chamberlain

Head of Approvals — Engineering

Handwritten signature of Greg Cooper in black ink.

Greg Cooper

Chief Executive

*The BBA is a UKAS accredited certification body — Number 113. The schedule of the current scope of accreditation for product certification is available in pdf format via the UKAS link on the BBA website at [www.bbacerts.co.uk](http://www.bbacerts.co.uk)*

*Readers are advised to check the validity and latest issue number of this Agrément Certificate by either referring to the BBA website or contacting the BBA direct.*

British Board of Agrément  
Bucknalls Lane  
Watford  
Herts WD25 9BA

©2013

tel: 01923 665300  
fax: 01923 665301  
e-mail: [mail@bba.star.co.uk](mailto:mail@bba.star.co.uk)  
website: [www.bbacerts.co.uk](http://www.bbacerts.co.uk)

# Regulations

In the opinion of the BBA, Bluebird Screw Tie Wall Connectors if installed, used and maintained in accordance with this Certificate, will meet or contribute to meeting the relevant requirements of the following Building Regulations (the presence of a UK map indicates that the subject is related to the Building Regulations in the region or regions of the UK depicted):



## The Building Regulations 2010 (England and Wales) (as amended)

<b>Requirement:</b> A1	<b>Loading</b>
<b>Comment:</b>	The product will contribute to the strength and stiffness of masonry walls provided the design loads are in accordance with sections 4.3 and 6.3 of this Certificate.
<b>Requirement:</b> B3(1)	<b>Internal fire spread (structure)</b>
<b>Comment:</b>	The product is non-combustible and will not adversely affect the fire resistance of the wall. See section 8 of this Certificate.
<b>Requirement:</b> C2(b)	<b>Resistance to moisture</b>
<b>Comment:</b>	Wall joints constructed using the product will resist the passage of moisture to the inside of the building. See section 7 of this Certificate.
<b>Requirement:</b> Regulation 7	<b>Materials and workmanship</b>
<b>Comment:</b>	The product is acceptable. See section 10 of this Certificate.



## The Building (Scotland) Regulations 2004 (as amended)

<b>Regulation:</b> 8(1)(2)	<b>Fitness and durability of materials and workmanship</b>
<b>Comment:</b>	The product is acceptable. See sections 9 and 10 and the <i>Installation</i> part of this Certificate.
<b>Regulation:</b> 9	<b>Building standards – applicable to construction</b>
<b>Standard:</b> 1.1	<b>Structure</b>
<b>Comment:</b>	Wall joints using this product will have satisfactory strength and stiffness provided the design loads are in accordance with sections 4.3 and 6.3 of this Certificate with reference to clauses 1.1.1 <sup>(1)(2)</sup> , 1.1.2 <sup>(1)(2)</sup> and 1.1.3 <sup>(1)(2)</sup> .
<b>Standard:</b> 2.3	<b>Structural protection</b>
<b>Comment:</b>	The product is non-combustible and will not adversely affect the fire resistance of the wall. See section 8 of this Certificate.
<b>Standard:</b> 3.10	<b>Precipitation</b>
<b>Comment:</b>	Wall joints constructed using the product will resist the passage of moisture to the inside of the building with reference to clauses 3.10.1 <sup>(1)(2)</sup> , 3.10.2 <sup>(1)(2)</sup> and 3.10.3 <sup>(1)(2)</sup> . See section 7 of this Certificate.
<b>Standard:</b> 7.1(a)(b)	<b>Statement of sustainability</b>
<b>Comment:</b>	The product can contribute to meeting the relevant Requirements of Regulation 9, Standards 1 to 6 and therefore will contribute to a construction meeting a bronze level of sustainability as defined in this Standard.
<b>Regulation:</b> 12	<b>Building standards – applicable to conversions</b>
<b>Comment:</b>	All comments given for this product under Regulation 9, also apply to this Regulation, with reference to clause 0.12.1 <sup>(1)(2)</sup> and Schedule 6 <sup>(1)(2)</sup> . (1) Technical Handbook (Domestic). (2) Technical Handbook (Non-Domestic).



## The Building Regulations (Northern Ireland) 2012

<b>Regulation:</b> 23(a)(i)(iii)(b)	<b>Fitness of materials and workmanship</b>
<b>Comment:</b>	The product is acceptable. See section 10 and the <i>Installation</i> part of this Certificate.
<b>Regulation:</b> 28	<b>Resistance to moisture and weather</b>
<b>Comment:</b>	Wall joints constructed using the product will resist the passage of moisture to the inside of the building. See section 7 of this Certificate.
<b>Regulation:</b> 30	<b>Stability</b>
<b>Comment:</b>	Wall joints constructed with the product will have satisfactory strength and stiffness provided the design loads are in accordance with sections 4.3 and 6.3 of this Certificate.
<b>Regulation:</b> 35	<b>Internal fire spread – structure</b>
<b>Regulation:</b> 36(a)	<b>External fire spread</b>
<b>Comment:</b>	The product is non-combustible and will not adversely affect the fire resistance of the wall. See section 8 of this Certificate.

## Construction (Design and Management) Regulations 2007

## Construction (Design and Management) Regulations (Northern Ireland) 2007

In the opinion of the BBA, there is no information in this Certificate which relates to the obligations of the client, CDM co-ordinator, designer and contractors under these Regulations.

# Additional Information

## NHBC Standards 2013

NHBC accepts the use of Bluebird Screw Tie Wall Connectors, when installed and used in accordance with this Certificate, in relation to *NHBC Standards, Part 6 Superstructure (excluding roofs), Chapter 6.1 External masonry walls.*

## Technical Specification

### 1 Description

1.1 Bluebird Screw Wall Tie Connectors (see Figure 1) comprise of components listed in Table 1.

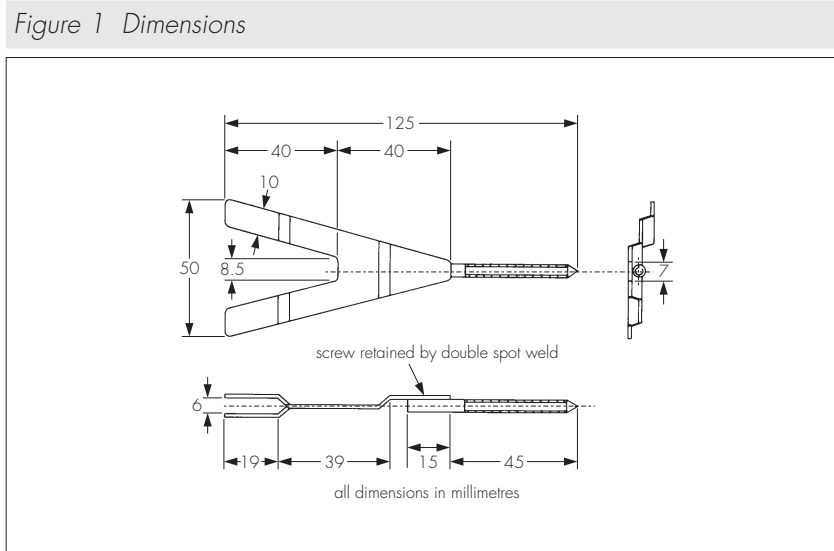

Table 1 Component specification

Component	Dimensional specification	Material specification
Screw (fishtail end) (see Figure 1)	80 mm long x 50 mm wide x 1.2 mm thick	Stainless steel or post galvanized mild steel <sup>(1)</sup>
Screw (screw thread)	No 10 x 60 mm (see Figure 1)	Stainless steel or post galvanized mild steel <sup>(1)</sup>
Wall plug	8 mm o.d. 40 mm long	nylon

(1) Austenitic stainless steel grade 304 S15 to BS EN 10088-2 : 2005 or post galvanized mild steel with minimum average coating weight of 610 gm<sup>-2</sup> to BS EN 10111 : 2008.

1.2 The ties comply with the requirements of DD 140-2 : 1987.

### 2 Manufacture

2.1 The product is manufactured from stainless steel or post galvanized mild steel.

2.2 As part of the assessment and ongoing surveillance of product quality, the BBA has:

- agreed with the manufacturer the quality control procedures and product testing to be undertaken
- assessed and agreed the quality control operated over batches of incoming materials
- monitored the production process and verified that it is in accordance with the documented process
- evaluated the process for management of non-conformities
- checked that equipment has been properly tested and calibrated
- undertaken to carry out the above measures on a regular basis through a surveillance process, to verify that the specifications and quality control operated by the manufacturer are being maintained.

### 3 Delivery and site handling

3.1 The wall tie connectors are delivered in boxes containing 100 screw connectors, 100 wall plugs with an instruction leaflet.

3.2 Each box carries identification of material type and bears the BBA identification mark incorporating the number of this Certificate.

# Assessment and Technical Investigations

The following is a summary of the assessment and technical investigations carried out on Bluebird Screw Tie Wall Connectors.

## Design Considerations

### 4 General

4.1 Bluebird Screw Tie Wall Connectors are suitable to tie new masonry walls ranging from 60 mm to 250 mm thick of up to three storeys (maximum height 8 metres) to existing masonry walls (see also section 6.2). The stainless steel connector is used for internal or external walls and the post galvanized mild steel connector is used for internal walls only.

4.2 The connectors are used to provide simple lateral support to masonry wall in conversion, extension and new building works and obviate the need for conventional toothing or bonding.

4.3 In addition to the requirements directly referred to in this Certificate, structures of brickwork or blockwork in which the system is incorporated must be designed and constructed to comply with one of the following technical specifications:

- BS EN 845-1 : 2003
- BS EN 846-5 : 2012
- BS EN 849-6 : 2012
- BS EN 1990 : 2002 + A1 : 2005
- BS EN 1996-3 : 2006
- PD 6697 : 2010
- The national Building Regulations:

*England and Wales* — Approved Document A1/2, Section 1C

*Scotland* — Technical Standards, Part C, *Small Buildings Guide*

*Northern Ireland* — Technical Booklet D.

4.4 Where particular sound insulation properties are required, eg separating walls, tests should be conducted in accordance with BS EN ISO 140-4:1998 and the results assessed in accordance with BS EN ISO 717-1:1997 and BS EN ISO 717-2:1997 to show compliance with the relevant Building Regulations.

### 5 Practicability of installation

The product is designed to be installed by a competent general builder, or a contractor, experienced with this type of product.

### 6 Strength

6.1 The product will provide simple lateral support to masonry wall panels in the context of PD 6697 : 2010.

6.2 Use of the product is limited to existing masonry of solid clay bricks, solid dense and lightweight aggregate concrete blocks and solid autoclaved aerated concrete blocks of minimum crushing strength  $2.8 \text{ N mm}^{-2}$ .



6.3 For the substrates referred to under section 6.2, the design shear strength of the product may be taken as 1.2 kN (0.12 kN per tie) over the height of one storey, ie 2400 mm with the ties spaced at a maximum of 225 mm. Where greater density and shear strength is required over one storey the spacing between the ties can be reduced.

6.4 In accordance with PD 6697 : 2010, the reaction along the edge of the wall may normally be assumed to be uniformly distributed.

6.5 As with conventional toothing and bonding, the designer must ensure that the existing wall has adequate strength, stability and integrity to accommodate the new wall.

6.6 The system is capable of accommodating vertical movement of up to 5 mm (for example, due to differential foundation movement), without a significant loss of strength. Brittle finishes, eg plaster and rendering, may be cracked where such movement occurs and may require repair.

### 7 Weathertightness



7.1 To prevent damage to the screw tie connectors by water penetration at the joint between the existing wall and the outer leaf of the new wall, either wax or bitumen impregnated foam sealing strip or polymer based sealant should be positioned either behind the screw tie wall connector carrier or in the junction perpendicular as shown in Figure 2.

Figure 2 Weather sealing details

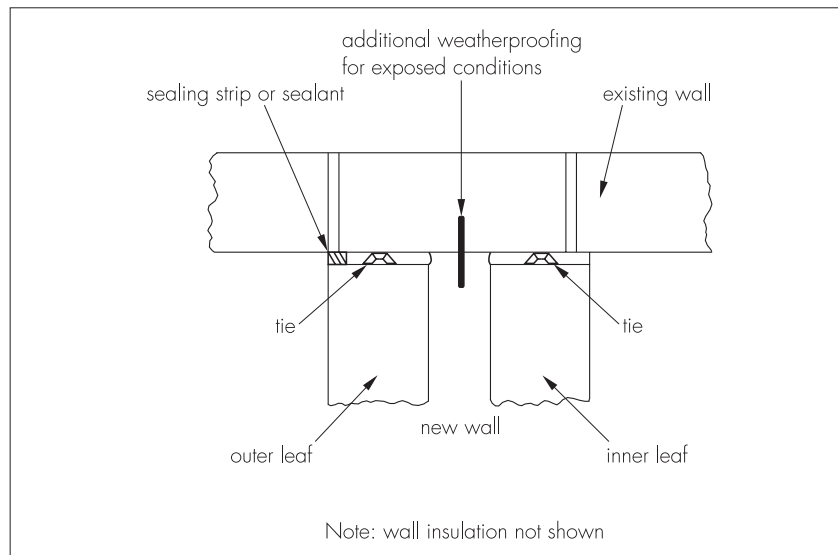

7.2 The weathertightness of the joint will not be affected by normal building movement.

7.3 Where exposure conditions can be classified as being equal to or in excess of moderate/severe (see PD 6697 : 2010), in common with other wall connector/starter systems and conventional toothing or bonding methods, additional protection from moisture penetrating to the inside of the building should be considered. This can take the form of an extended vertical dpc, as shown in Figure 2, which will prevent moisture from being transmitted through the existing masonry wall and also shed any moisture that may penetrate the perpendicular joint to the bottom of the new wall cavity.

## 8 Performance in relation to fire



Where the walls are required to have a one-hour fire resistance, use of the products will have no significantly adverse effect on the fire resistance of either the existing or new wall.

## 9 Maintenance



As the ties are contained within the walls, maintenance is not required.

## 10 Durability



The wall connectors will not be adversely affected by mortars (including those incorporating conventional mortar admixtures).

## 11 Reuse and recyclability

The product is manufactured from steel that can be fully recycled.

# Installation

## 12 General

12.1 Bluebird Screw Tie Wall Connectors must be installed according to the Certificate holder's instructions.

12.2 The existing masonry must be structurally sound.

12.3 The wall connectors must be fixed into bricks or blocks and not into mortar joints, and at least 25 mm from the edge of the wall.

12.4 For cavity wall construction wall connectors must be used with each leaf.

12.5 For external walls the vertical joint between the existing wall and the outer leaf of the new wall must be weathersealed as detailed under section 7.

## 13 Preparation

Rendered or pebble-dashed finishes should be removed to ensure that wall connectors are fixed directly to the existing masonry.



## 14 Procedure

14.1 The sequence of installation is shown in Figure 3.

Figure 3 Sequence of installation

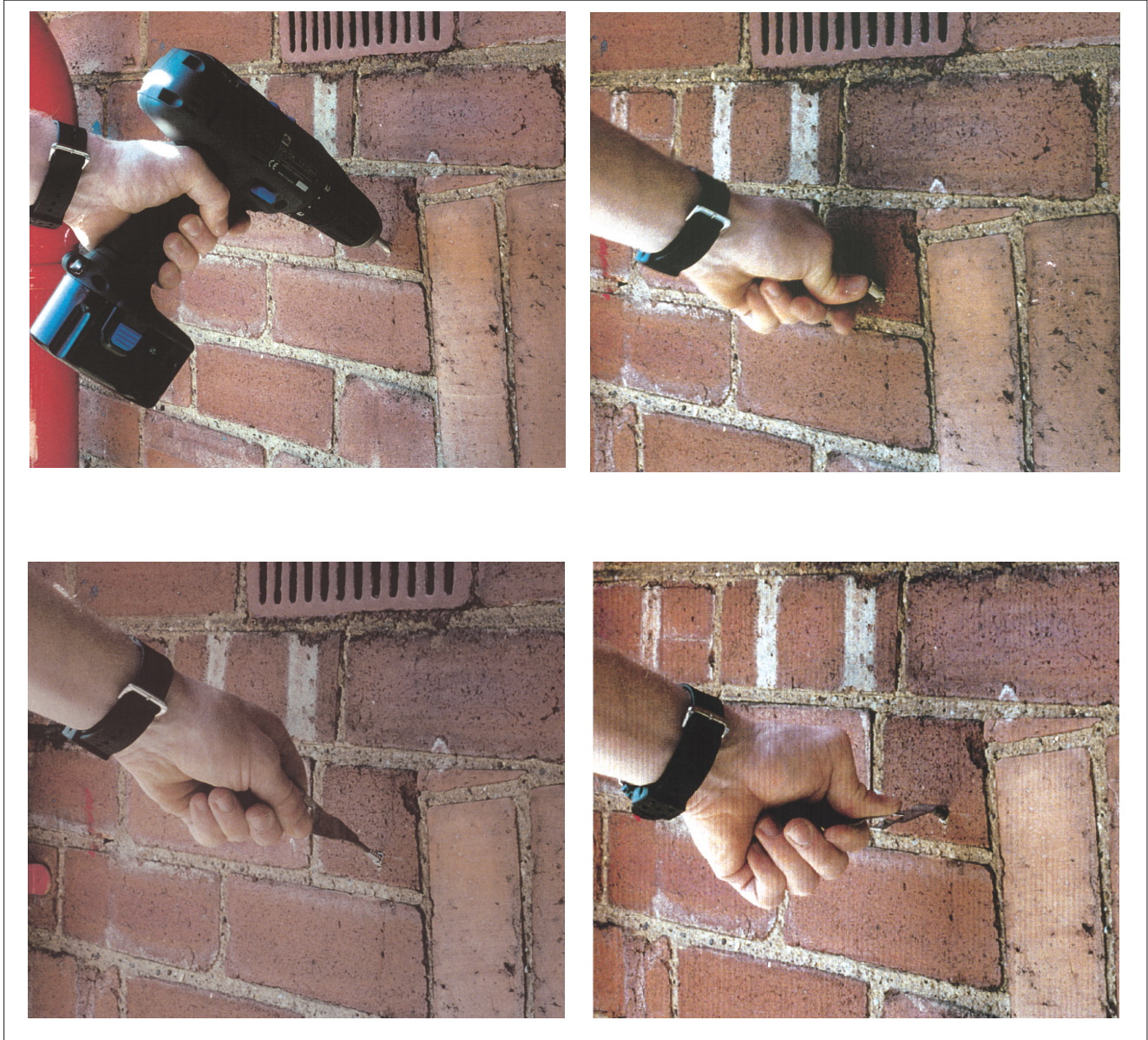

14.2 A vertical line is marked on the existing wall at the centre of the proposed new wall.

14.3 The wall connectors are installed starting with the lowest connector at the bottom of the proposed joint and working upwards to the highest connector.

14.4 The positions of the wall connectors are marked as shown in Figure 4. It is essential that the wall connectors are spaced vertically at a maximum of every three courses of brickwork (nominally 225 mm).

Figure 4 Screw tie positions

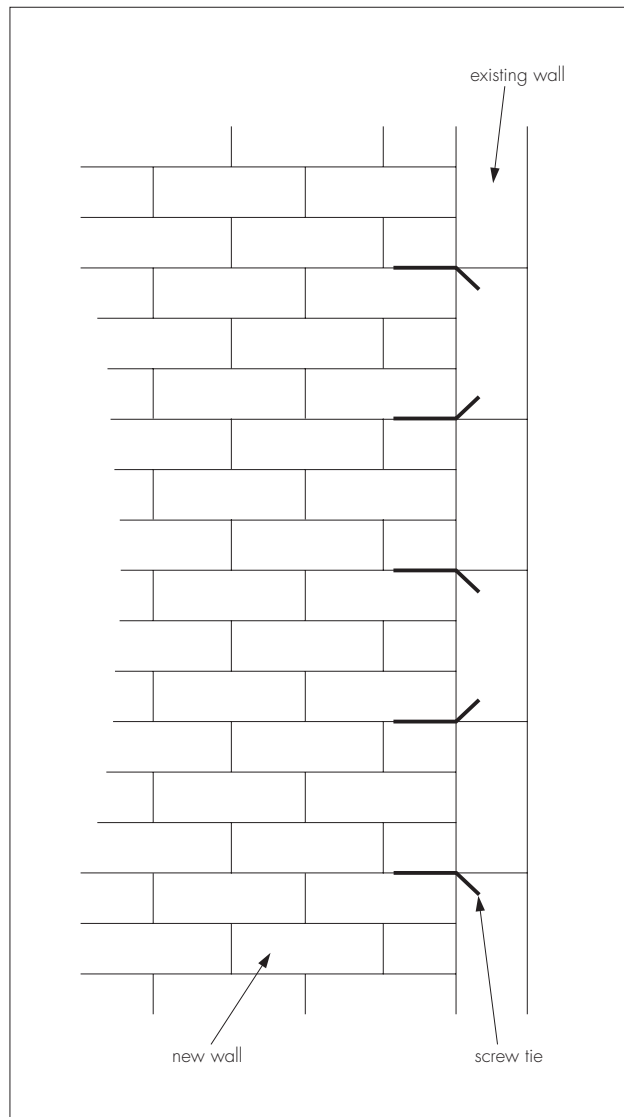

14.5 The first hole is drilled downwards at an angle to the horizontal of approximately  $30^\circ \pm 5^\circ$ , always drilling into the masonry substrate. An 8 mm diameter masonry drill bit is used and the depth of the hole is 45 mm. The wall plug is inserted and pushed to the end of the hole. The next hole is similarly drilled and plugged but the fixing hole must be drilled upward at a  $30^\circ$  angle to the horizontal. This procedure is repeated ensuring that the fixing holes are drilled in alternate directions at each subsequent wall connector position.

14.6 The wall connectors are screwed fully into the wall plugs.

14.7 When specified, the impregnated foam sealing strip or polymer based sealant is positioned (see section 7.1 and Figure 2).

14.8 Brickwork or blockwork for the new wall is laid in the conventional way with a full mortar joint between the existing and the new walls. The fishtail ends of the wall connectors are bent to lie horizontally in the mortar bed and a mortar bed is applied over the top so that the fishtail ends are completely embedded in mortar.

14.9 When specified, at the completion stage of the new wall, the impregnated foam sealing strip or polymer based sealant is inserted at the junction perpendicular (see section 7.1 and Figure 2).

14.10 If required, the extended vertical dpc is inserted into the aperture cut as described in section 7.3.

## 15 Tests

Tests were carried out to establish the load deflection characteristics of:

- component parts
- laterally loaded wallties.

## 16 Investigations

16.1 Calculations were made and examined, in conjunction with the results of the load deflection tests (see section 15), to establish structural performance.

16.2 Existing information relating to the suitability of the corrosion protection and compatibility of materials in contact, was examined.

16.3 Data relating to the effects of the product on the weathertightness of cavity walls were examined.

16.4 Trials were conducted to assess the practicability of installation.

16.5 An assessment was made of the behaviour of the system in fire.

16.6 The manufacturing process was examined, including the methods adopted for quality control, and details were obtained of the quality and composition of the materials used.

## Bibliography

BS EN 845-1 : 2003 *Specification for Ancillary Components of Masonry*

BS EN 846-5 : 2012 *Methods for Test for Ancillary Components of Masonry*

BS EN 849-6 : 2012 *Methods for Test for Ancillary Components of Masonry*

BS EN 1990 : 2002 + A1:2005 *Eurocode — Basis of Structural Design*

BS EN 1996-3 :2006 *Eurocode 6 — Design of masonry structure*

BS EN 10088-2 : 2005 *Stainless steels — Technical delivery conditions for sheet/plate and strip of corrosion resisting steels for general purposes*

BS EN 10111: 2008 *Continuously hot rolled low carbon steel sheet and strip for cold forming — Technical delivery conditions*

BS EN ISO 717-1 : 1997 *Acoustics — Rating of sound insulation in buildings and of building elements — Airborne sound insulation*

BS EN ISO 717-2 : 1997 *Acoustics — Rating of sound insulation in buildings and of building elements — Impact sound insulation*

BS EN ISO 140-4 : 1998 *Acoustics — Measurement of sound insulation in buildings and of building elements — Field measurements of airborne sound insulation between rooms*

DD 140-2 : 1987 *Wall ties — Recommendations for design of wall ties*

PD 6697 : 2010 *Recommendations for the design of masonry structures to BS EN 1996-1-1 and BS EN 1996-2*



## 17 Conditions

17.1 This Certificate:

- relates only to the product/system that is named and described on the front page
- is issued only to the company, firm, organisation or person named on the front page — no other company, firm, organisation or person may hold or claim that this Certificate has been issued to them
- is valid only within the UK
- has to be read, considered and used as a whole document — it may be misleading and will be incomplete to be selective;
- is copyright of the BBA
- is subject to English Law.

17.2 Publications, documents, specifications, legislation, regulations, standards and the like referenced in this Certificate are those that were current and/or deemed relevant by the BBA at the date of issue or reissue of this Certificate.

17.3 This Certificate will remain valid for an unlimited period provided that the product/system and its manufacture and/or fabrication, including all related and relevant parts and processes thereof:

- are maintained at or above the levels which have been assessed and found to be satisfactory by the BBA
- continue to be checked as and when deemed appropriate by the BBA under arrangements that it will determine
- are reviewed by the BBA as and when it considers appropriate.

17.4 The BBA has used due skill, care and diligence in preparing this Certificate, but no warranty is provided.

17.5 In issuing this Certificate, the BBA is not responsible and is excluded from any liability to any company, firm, organisation or person, for any matters arising directly or indirectly from:

- the presence or absence of any patent, intellectual property or similar rights subsisting in the product/system or any other product/system
- the right of the Certificate holder to manufacture, supply, install, maintain or market the product/system
- individual installations of the product/system, including their nature, design, methods, performance, workmanship and maintenance;
- any works and constructions in which the product/system is installed, including their nature, design, methods, performance, workmanship and maintenance
- any loss or damage, including personal injury, howsoever caused by the product/system, including its manufacture, supply, installation, use, maintenance and removal.
- any claims by the manufacturer relating to CE marking.

17.6 Any information relating to the manufacture, supply, installation, use, maintenance and removal of this product/system which is contained or referred to in this Certificate is the minimum required to be met when the product/system is manufactured, supplied, installed, used, maintained and removed. It does not purport in any way to restate the requirements of the Health and Safety at Work etc. Act 1974, or of any other statutory, common law or other duty which may exist at the date of issue or reissue of this Certificate; nor is conformity with such information to be taken as satisfying the requirements of the 1974 Act or of any statutory, common law or other duty of care.