



ASPI-JET

OPERATORS HANDBOOK



General running data Dental aspirator

Model	Aspi-Jet 6-7-8-9 Y
Rated voltage	230 V
Rated frequency	50 Hz
Rated current	3,1 A
Insulation class	Class I
Type of appliance	B
Use	continuous service
Protection against liquids	common
Level of protection against direct or indirect contact	type B
Room conditions (temperature)	from + 5 °C to + 40 °C
Motor protected by thermal device	
Output power	0,4 kW
Maximum flow	1250 l/min
Maximum operating head for continuous service	1300 mm H ₂ O
Sound pressure level	60 dB(A)*
Other available tensions: 240 V ~ 50 Hz 2,95 A - 220 V ~ 60 Hz 3,5 A, 120 V ~ 60 Hz 6,0 A - 110 V ~ 60 Hz 7,0 A	
This appliance cannot work in contact with a flammable anaesthetic mixture with air, oxygen or nitrous oxide	

~	Alternating current	IEC 417-5032
⊕	Earthing	IEC 417-5019
♂	Type B appliance	IEC 878-02-02
○	Off	IEC 417-5008
	On	IEC 417-5007
☒	Cup-filler	ISO 7000-1854
☒	Bowl flush	ISO 7000-1855

*Sound pressure level tested (with tip N° 11, open) according to ISO 3746-1979 (E) regulation.
Parameters: r/d=1 - Background noise < 35 dB (A) - Instruments: Brüel & Kjær Type 2232.

ASPI-JET 6 γ	ASPI-JET 7-8-9 γ
1 On/Off Switch	1
2 Exhausted air silencer	2
3A Fluids conveying pipe	3A
3B Aspirated air conveying pipe to motor	3B
3C Exhausted air conveying pipe to silencer	3C
4 Aspirated liquids manifold	4
5 Canister	5
- Draining valve	6
7 Maximum level probes	7
- Draining pump	8
- Filter on canister cover	10
- Fluids tube holder sleeve	11
- Feeding water pressure reducer	12
- Feeding water filter	13
14 Uni-Jet 75 aspiration unit	14

ASPI-JET 6 γ

ASPI-JET 7-8-9 γ

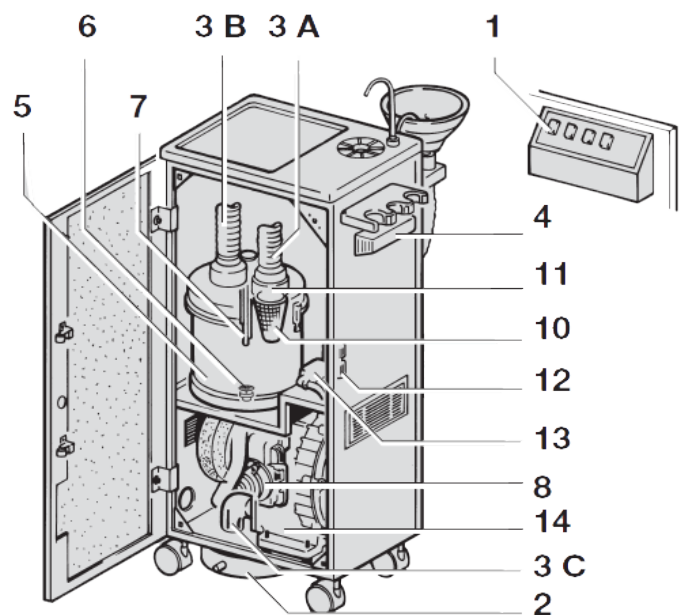
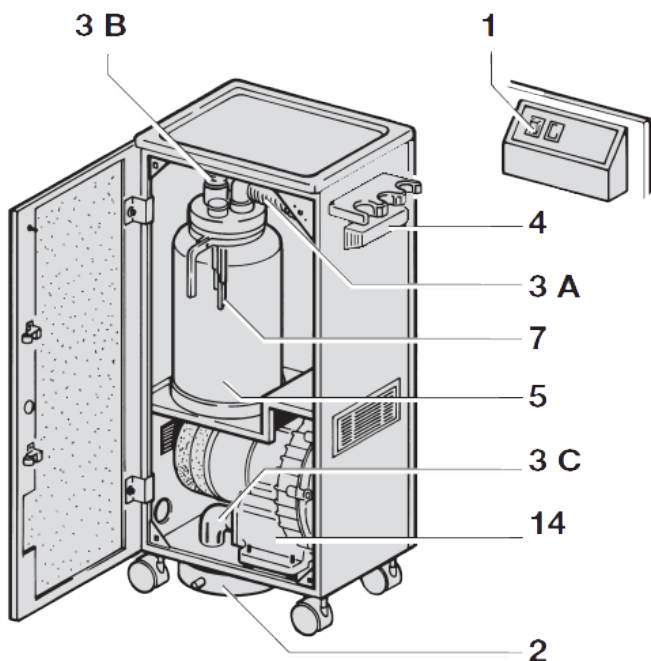

CERTIFICATION OF MEDICAL EQUIPMENT ACCORDING TO DIRECTIVE 93/42/CEE

Further to DNV accreditation for applying CE marking to those of our appliances that are classified as medical equipment:

ASPI-JET Models 6-7-8-9 γ

servicing authorized engineers shall use only original CATTANI spare parts when repairing the above appliances. Moreover, with reference to the components listed here below, whose lot and supplier must be easily traced, engineers shall refer to the following table:

Components	Code	
MOTOR UNI-JET 75	020354	110 V \sim 60 Hz
	020348	230 V \sim 50 Hz
	020349	240 V \sim 50 Hz
	020353	220 V \sim 60 Hz
PRINTED BOARD	180921	AC 15 CIRCUIT -230 V \sim
	180923	AC 15 CIRCUIT -110 V \sim
	180930	CIRCUIT +pump -220 V \sim
	180931	CIRCUIT +pump -240 V \sim
	180940	AC 20 CIRCUIT -220 V \sim
	180941	AC 20 CIRCUIT -240 V \sim
	180943	AC 20 CIRCUIT -110 V \sim
DOOR MICRO SWITCH	183102	
ASS. CABLE W/MICRO	180810	

While submitting an order for the above components to the sales department of CATTANI S.p.A, they shall also indicate

SERIAL NUMBER

of the concerned appliance, committing to install the components to that appliance and not to others.

Introduction

The following presentation aims at illustrating the equipment and systems dealt with herein to users and engineers; it also aims at explaining operation and maintenance, as well as the dangers with the precautions required for accident prevention.

Signals

- Electrical shock risk: also 230 V can lead to death.
- Biological danger, risk of infections from epidemic diseases.
- High temperature.
- General danger sign.
- Compulsory direction of flow and of rotation.
- Signals

Signs cannot always fully express danger warnings, therefore it is necessary that the user reads the warnings and keeps them in due consideration. Failure to respect a danger sign or warning may harm operator or patient.

Do not remove protections; do not tamper with machines or their operation.

Despite all our efforts, it is still possible that danger warnings are not exhaustive: we apologise with the users and kindly request them to care for all danger sources that might have pass unnoticed and to inform us accordingly.

Recommendations

The retailer or the installation engineer will take care to train the surgery staff with trials on a brand new, non-contaminated appliance.

The installation of the Aspi-Jet is reserved to dental engineers authorized by the manufacturer. Aspirated debris is always contaminated and infected: for this reason, we stress that the greatest care must be used to prevent contamination of operators or the environment. Contamination may also result from an appliance in bad working order so we recommend to contact only dental engineers whose teaching and training is duly certified by the manufacturer. Any modification of the appliance must be agreed upon with the manufacturer.

General Features

Our mobile aspirators supply a good aspiration independent from the dental unit; the trolleys allow use in any working position. The aspirator type 6 γ (canister to be emptied manually) can be moved quickly from one surgery to another; for this reason it can be used as an emergency aspirator to support the centralized plant or the aspiration system of the dental unit.

Aspi-Jet 7 γ is fitted with automatic drainage, it must be connected to the waste of the building. Besides the general features of Aspi-Jet 7 γ Aspi-Jet 8 γ and Aspi-Jet 9 γ offer some additional function: water supply to the tumbler and spittoon (cuspidor) with rinsing respectively. The switches which control the above functions are marked with symbols and are located on the front panel:

- a tumbler indicates the water supply on type 8 γ
- a tap indicates rinsing of the spittoon on type 9 γ

General installation and starting tips

- Unpack the appliance following the instructions shown on the package.
- Dispose of the package in compliance with regulations.
- Verify that the appliance has not been damaged during transport.
- Do not connect damaged appliances to the mains.
- Do not use extension leads, multiple plugs or sockets.
- Ascertain that the feeding line is adequate to feed the machine.
- Assembly of the aspirator must be carried out by an expert, with suitable equipment and special training. The installer should read the equipment manual, perform commissioning and instruct the users in the use and routine maintenance of the new machine while it is still unused and therefore not contaminated.
- The air exhausted by the aspiration system should be filtered, with a special certified antibacterial filter available on request, and expelled to the outside.
- After installation, perform the required safety and operating tests.
- Arrange for periodical inspection of the equipment. This will not only prevent stoppage of a chair or of the whole surgery, but is also a way to prevent injuries and accidents.
- You can find all our updated manuals at our website: www.cattani.it. We recommend that you consult them, especially for updates on the subject of safety.

Installation

The aspirator must be installed in compliance with CEI 62-5 regulation for electro-medical appliances (Aspi-Jet 6-7-8-9 γ have been designed accordingly). Prior to plugging in the unit, check the specifications on the label and make sure that the mains are compatible with the appliance and protected against overcurrent according to CEI 64/8 regulations. The appliance must be protected against indirect contacts for class appliances according to CEI 64-8 reg. and 64-4 for rooms used as medical consulting rooms (IEC correspondents available on demands). The plug and cable are equipped with earthing protection: do not remove this protection in any case and make sure that the socket is compatible.

Once installation has been completed, the unit can be switched on by pressing the main switch 1 located on the front panel; the switch will light up and aspiration will start by lifting one of the terminals from its seat. If you open the cabinet door the electrical circuit is open and the aspirator stops. In standard assembled units aspirated air is exhausted through the silencer (2) (Fig. A). In order to convey exhausted air outside you need to fit an extension to hose 3C and drive it outside (Fig. A). Most of the noise and bacteria will be carried outside together with air; we can also supply a certified bacterial filter for exhausted air. When installing Aspi-Jet 8 γ and 9 γ , besides all general directions and regulations mentioned, the engineers shall:

- connect the water supply, without removing the antispray tube 15 (Fig. B), which protects the Rilsan tube against bursting;
- check any possible leaking, especially near parts subject to tension;
- adjust water pressure to a max of 4 bar by using the pressure control device 12 (Fig. B).

Operation and use

Aspirated liquids and air are conveyed to the manifold (4) through the tip and lifted hose and into the canister through tube 3A (page 3); inside the canister liquids are separated from air.

The air is driven all the way to the motor (through pipe 3B) and is then exhausted, while liquids are heavier and are collected at the bottom of the canister.

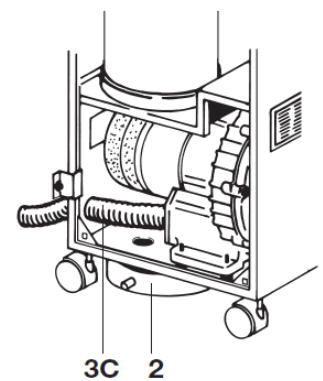

Fig. A

Aspi-Jet 6 γ is equipped with a canister (5) whose capacity allows 8/10-hour continuous service before reaching maximum level, therefore the canister needs emptying every evening after work.

Aspi-Jet 7 γ has automatic drainage: a valve (6) located at the bottom of the canister is kept close by depression when suction is performed; on the contrary, when all terminals are on their seats suction stops and liquids are drained out of the canister. In case the canister should fill up during surgical operations, the probes (7) will sense maximum level at about 3/4 of the canister (shortest-probe level); the electrical circuit opens and suction stops, while a yellow-light indicator located on the front panel warns that the canister is full.

For Aspi-Jet 6 γ you need to switch the unit off and empty the canister manually; for Aspi-Jet 7 γ , as mentioned above, the draining valve opens and the draining pump (8) (page 3) starts working. In a few seconds the canister is empty and suction starts again automatically.

During surgical operations, foam build-up, caused by blood and aspirated air, can reach probe level causing the unit to stop; in this case we suggest the use of our solid anti-foaming (directions for use are inside the package - Fig. B1). In case some failure (clogging of cooling system, breakdown etc.) should cause overheating of the motors - $>120^{\circ}\text{C}$ for Uni-Jet 75 suction unit and $>90^{\circ}\text{C}$ for draining pump (8) - a thermal device rated at a fixed temperature opens the circuit and resets it automatically, when the temperature of the windings is back to normal. Should this happen, identify and eliminate the cause.

Notice

Prior to starting any servicing operation on appliances that have been used, clean with Puli-Jet plus new or Eco-Jet 2 a few times as explained in the maintenance section. Use disposable GLOVES (Fig. B3), GOGGLES, MASK and OVERALL.

Maintenance and cleaning

- Electrical shock risk: also 230 V can be lethal.
- Biological danger, risk of infections from epidemic diseases.
- High temperature.
- Compulsory direction of flow and of rotation.

Together with liquids some solid particles may be sucked in, therefore it is necessary to have filters in order to protect the motor and recover wanted particles.

Aspi-Jet 6 γ is provided, like all other models, with a debris filter 9 (Fig. C) which can be checked from outside the cabinet; Aspi-Jet 7 γ is provided with a filter (10) on the canister cover.

Filters must be cleaned every day. In order to remove the filter 9, first turn the unit on and aspirate only air for some seconds so that hoses and manifold dry out; disconnect the power supply line, lift the terminals from their seat and remove manifold 4 (Fig. C) pulling the filter outwards by its handle. To check filter 10 lift bent pipe union 11 (Fig. D). For Aspi-Jet 6 γ , every evening, once disconnected the power supply line, loosen the two rubber bands and remove lid: take out canister, empty and clean (Fig. E).

For Aspi-Jet 7-8-9 γ the canister must be removed fortnight, cleaned and disinfected.

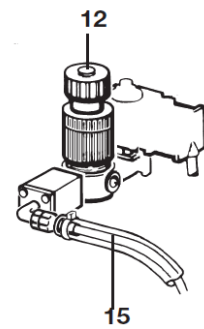

Fig. B



Disinfecting antifoaming agent for dental aspirators

Fig. B1



Puli-Jet plus new with anti-scale agent

Fig. B2

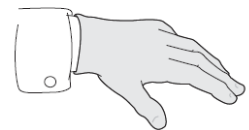

Fig. B3

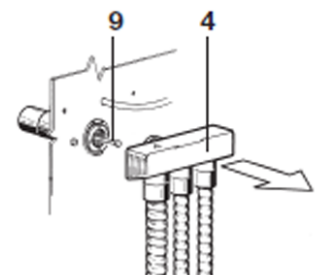

Fig. C

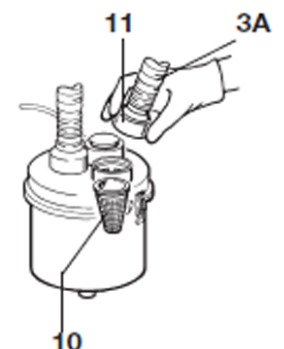

Fig. D

Canisters, covers and probes of all models once a week must be accurately cleaned with a sponge and Puli-Jet plus diluted in hot water.

Every evening, after cleaning the filters, it is important to aspirate Puli-Jet plus diluted in hot water; to prepare the Puli-Jet plus solution follow the instructions on the bottle.

Disinfection and cleaning should be carried out by means of Pulse Cleaner (Fig. F). Once rinsing is completed, Aspi-Jet 7-8-9 γ carry out drainage automatically, while for Aspi-Jet 6 γ the canister is to be emptied once again. Puli Jet plus dissolves blood and mucus and performs an anti-microbial action; if used regularly, every day with hot water, Puli-Jet plus removes old scalings and disagreeable smells.

Do not use detergents, even with reduced foaming, as aspirated air volume and turbulence may cause foam build up and damage the suction unit, make it stop and produce disagreeable smells.

O-rings (tightening rings) and sliding closures of terminals (Fig. G) must be lubricated with Lubri-Jet spray every 15 working days. It is advisable to replace all hose of the plant (Fig. H), especially outside the unit, and terminals periodically for sanitary and functional reasons (flexibility and lightness of hose, smoothness of sliding closures).

Main cleaning and maintenance operations

- After every patient, replace or disinfect the external hose (preferably with Eco-Jet 1).
- After every surgical operation or any long operation: rinse the appliance by aspirating hot water.
- At noon, before lunch time, clean the system with Puli-Jet plus (sanitizing at 4% - disinfecting at 8%).
- After each working day: clean filters, clean plant with disinfecting Puli-Jet plus and hot water.
- Once every fortnight clean the canister, draining valve and probes; lubricate OR and sliding closures of terminals with spray silicon.

Notice

Prior to starting any servicing operation on appliances that have been used, clean with Eco-Jet 2 a few times as explained in the maintenance section. Use disposable GLOVES (fig. B3), GOGGLES, MASK and OVERALL.

Maintenance operations meant for engineers

- Electrical shock risk: even 230 V power can be lethal.
- Biological danger, danger of infections from epidemic diseases.
- Compulsory direction of flow and rotation sense.

Further to the maintenance operations listed so far, for Aspi-Jet 8 and 9 γ you also need to check the water filter 13 (Fig. I).

Periodically: replace terminals and hose outside the unit. The engineer shall check, siphons and outlets, all internal piping, plastic and rubber subject to ageing. Before servicing any used equipment, carry out some washing operations with Puli-Jet plus new with anti-scale agent.



Fig. E



Fig. F

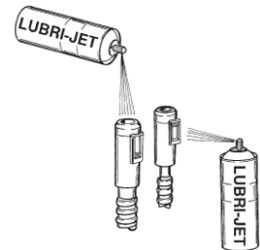

Fig. G

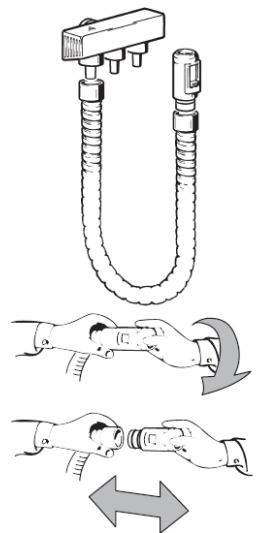

Fig. H



13

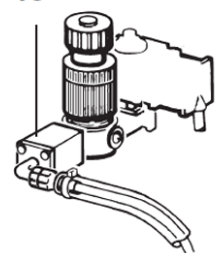

Fig. I

Disconnect electric supply and padlock mains switch if provided.

Before servicing the equipment wear disposable gloves, goggles, mask.

Aspirated debris is infected and contaminated, moreover the appliances to be serviced could be under pressure and the risk of contaminating splashes is clearly higher.

Short-circuit probes and check:

- switching off of aspiration unit, and
- switching on of draining pump.

Remove the lid and pull out the draining pump, ensure it is working and clean the area before replacing it. For every replacement, use original spare parts. Check the conditions of tubes carrying aspirated liquid; in particular the part after the draining pump; in case of cracks, however small, pipes must be replaced.

Make sure that the personnel in charge of cleaning and sanitising operations remember their maintenance tasks and that they use the recommended products and procedures: it is the responsibility of the engineer in charge of general maintenance to instruct surgery staff as to the daily maintenance routine required. Do not alter the equipment or their functioning.

Notice

Prior to starting any servicing operation on appliances that have been used, clean with Eco-Jet 2 a few times as explained in the maintenance section. Use disposable GLOVES (fig. B3), GOGGLES, MASK and OVERALL.

Maintenance operations meant for engineers

- Electrical shock risk: even 230 V power can be lethal.
- Biological danger, danger of infections from epidemic diseases.
- Compulsory direction of flow and rotation sense.

Further to the maintenance operations listed so far, for Aspi-Jet 8 and 9 γ you also need to check the water filter 13 (Fig. I).

Periodically: replace terminals and hose outside the unit. The engineer shall check, siphons and outlets, all internal piping, plastic and rubber subject to ageing.

Before servicing any used equipment, carry out some washing operations with Puli-Jet plus new with anti-scale agent.

Disconnect electric supply and padlock mains switch if provided.

Before servicing the equipment wear disposable gloves, goggles, mask.

Aspirated debris is infected and contaminated, moreover the appliances to be serviced could be under pressure and the risk of contaminating splashes is clearly higher.

Short-circuit probes and check:

- switching off of aspiration unit, and
- switching on of draining pump.

Remove the lid and pull out the draining pump, ensure it is working and clean the area before replacing it. For every replacement, use original spare parts. Check the conditions of tubes carrying aspirated liquid; in particular the part after the draining pump; in case of cracks, however small, pipes must be replaced.

Make sure that the personnel in charge of cleaning and sanitising operations remember their maintenance tasks and that they use the recommended products and procedures: it is the responsibility of the engineer in charge of general maintenance to instruct surgery staff as to the daily maintenance routine required.

Do not alter the equipment or their functioning.

Important Notice

- Periodical inspections according to IEC-EN-60601-1 standard.
- Inspection periodicity suggested by the manufacturer: 12 months.
- The manufacturer is willing to supply spare parts, technical information and any other information that might be needed.
- Distributors, agents authorized retailers and technicians are supplied with split-up drawings, electrical diagrams, hand books and updating, as for servicing and maintenance.
- The appliance is guaranteed for one year from date of sale, provided that guarantee card addressed to manufacturer is returned to the manufacturer reporting date of sale, retailer stamp and customer's name.
- Guarantee and manufacturer liability cease in case appliances and/or plants are found tampered by any kind of action performed by unable and thus unauthorised people.
- For any use not contemplated or specified in this handbook please refer to manufacturer.
- Aspi-Jet is a EEE device and consequently it is subject to WEEE (Waste of electric and electronic equipment) regulations.
- On the web site www.cattani.it, you can find our updated manuals. We recommend to consult them, with special attention to the security updating.
- You can get the printed manual anytime from our authorized dealers.

Transport and Storage

- Packed equipment can be transported and stored at a temperature range of -10 °C +60 °C.
- Packages must be kept away from water and splashing and cannot tolerate humidity >70%.
- Packages with the same weight can be stored in piles of three only.

Transport of second hand appliances

- Prior to packing cleanse and sanitize with Puli-Jet plus (see maintenance and cleaning).
- Place unit into a polyethylene bag, seal and pack in 3-layer corrugated board.

ITALIAN PATENTS OR PATENT APPLICATIONS:

CATTANI: 1201707 - 1234828 - 1259318 - 1.187.187 - 1253460 - 233634 - 2337706 -1294904

ESAM: 1225173 - 1253783 - 0791751

FOREIGN PATENTS OR PATENT APPLICATIONS:

CATTANI: AU 546.143 - US 4,386,910 - US 4,787,846 - US 5,039,405 - US 5,002,486 - AU 580839 - US 4,684,345 - US 5,330,641 - AT 0040181 - CH 0040181

- DE 0040181 - FR 0040181 - GB 0040181 - LU 0040181 - SE 0040181 - CH 0211808 - DE 0211808 - FR 0211808 - GB 0211808 - SE 0211808 - DE 0335061

- ES 0335061 - FR 0335061 - GB 0335061 - AT 0557251 - DE 0557251 - ES 0557251 - FR 0557251 - GB 0557251 - DE 0638295 - DK 0638295 - ES 0638295

- FR 0638295 - GB 0638295 - NL 0638295 - SE 0638295 - US 6,083,306 - US 6,090,286 - US 6,022,216

ESAM: US 4,948,334 - DE 0351372 - ES 0351372 - FR 0351372 - GB 0351372 - EP 0791751 - US 5,779,443 - CH 0791751 - DE 0791751 - ES 0791751

- FR 0791751 - GB 0791751 - PT 0791751 - AU 93321 - ES 107358 - FR 222.394/395

PENDING PATENT

CATTANI: IT M098A000019 - IT M098A000119 - EP 99830010.7 - EP 99830011.5

EP 99830250.9 - EP 00830491.7 - IT M099A000165 - US 09/624,182



For further information, please contact

Cattani ESAM UK Limited, 21a Harris Business Park, Hanbury Road, Stoke Prior,

Bromsgrove, Worcestershire, B60 4DJ

t: 01527 877997 **f:** 01527 839799 **e:** info@cattaniesam.co.uk **w:** www.cattaniesam.co.uk