



# ARIAN



*British designed and built for British farmers*



1500L with 24m boom







# ARIAN



## Standard features



### Controls

**Standard in-cab spray and pressure controls** from one control box mounted in the cab.



**Hydraulic spray functions** are mounted at the rear and protected by a moulded cover.



**Work station** controlling primary functions to operate the sprayer and when cleaning or filling.

### Dry tank level sight gauge

**Chemical induction:**  
25L stainless steel hopper for safe transfer of liquids and powders via a high pressure venturi system to the main tank, a rotary nozzle for cleaning containers.



**Diaphragm pump:**  
High quality poly' diaphragm pump withstands any aggressive plant protection chemicals.



**Clothes storage:**  
25L clothing and PPE locker.



**Clean water supply:**  
100L for tank rinsing and boom flushing.

**Hand wash:**  
15L clean water supply.

### Booms

**Boom construction:**  
All booms are manufactured from steel tubular sections. The three dimensional structure guarantees strength and durability.

All nozzles and spray lines are secured above the base of the boom for protection against accidental damage.

**Boom adjustment:**  
All pivot points and fold rams can be adjusted to counteract wear.

**Hose & cable guide** tidies and protects hoses and cables.

**Boom storage system:**  
Secures boom assembly in the folded position for safe road transport.

**Break back:**  
All booms are fitted with break back pivot points to protect against unforeseen obstacles.

**Boom flexibility:**  
It is possible to work with the boom part-folded:

- 18 to 9m
- 20 to 11m
- 21 to 11m
- 24 to 12m





# ARIAN

## Optional extras



**Tank options:** 1000L, 1200L, 1500L

**Rear fold boom options:** 18, 20, 21 & 24M



**Computerised spray rate controller** automatically adjusts spray application relative to forward speed via traditional magnet and sensor, ISO pick-up or GPS radar.

GPS boom sectional switching available.



**Variable boom geometry** enables the operator to individually lift either side of the boom to match contoured land (see below).

### Front tank:

**600 - 1500L tank options**  
600L capacity; hydraulically driven transfer pump (700LPM). Incab electric transfer controls. Bull-bar complete with road lighting; 3 point linkage frame.



### Triple nozzle assemblies

enable the operator to select from a choice of 3 nozzle sizes for various applications.



### Other optional extras

Air shut-off and liquid recirculation, stainless steel spray lines, bout/foam marker, one-side boom fold (*outer section only*), retractable hose reel for cleaning.







# ARIAN



## Technical specifications

| Item                              | Dimension   |
|-----------------------------------|---|
| Tank capacities (L)               | 1000, 1200, 1500  |
| Pumps (type / L per min)          | Poly 2180 / 180; Poly 2250 / 250                                  |
| Boom lengths <b>side fold</b> (m) | 18, 20, 21, 24  |
| Boom lengths <b>rear fold</b> (m) | 18, 20, 21, 24  |
| Hydraulic outlet required         | one single acting and two double acting valves (standard machine) |
| Weight (Kg)                       | 1200 (side fold); 1500 (rear fold)                                |
| Total height (m)                  | 3.2 (24m rear fold); 3.8 (24m side fold)                          |
| Total width (m)                   | 2.4 (24m rear fold); 2.7 (24m side fold)                          |
| Rinse tank (L)                    | 100   |

**Notes:** The Arian is available with a range of booms from 18 to 24m. All booms have pendulum system and anti-yaw damping. The Arian chassis and boom have been designed to meet the rigorous demands of any farming environment, the reclined chassis design avoids the need for front stabilisation and when lifted, a vertical position is achieved without any adjustment.

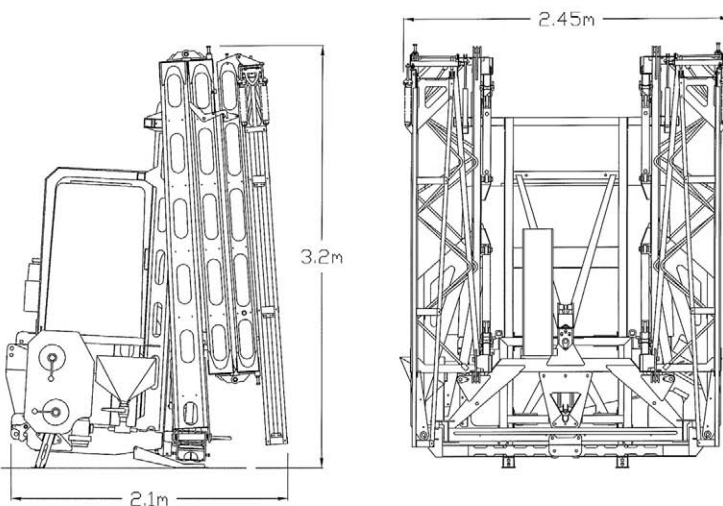
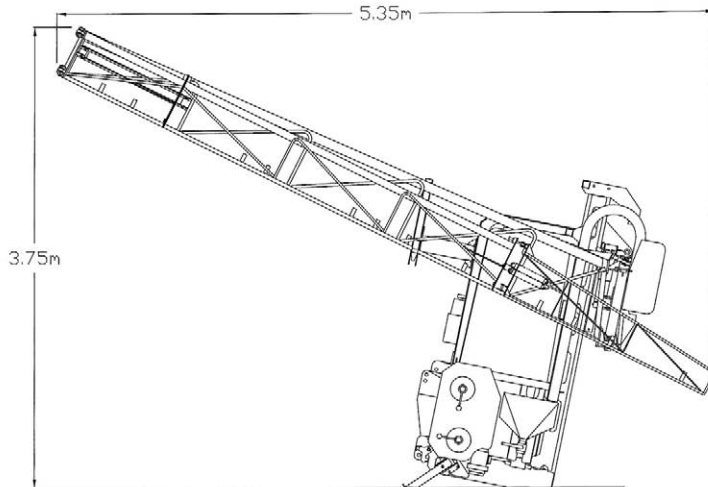

### Team Sprayers Limited

Unit 3 Lancaster Way Business Park  
 Witchford, Ely, Cambs CB6 3NW  
 Tel: 01353 661 211 Fax: 01353 666 642  
 Email: [sales@team-sprayers.com](mailto:sales@team-sprayers.com)  
[www.teamsprayers.com](http://www.teamsprayers.com)



*Leaders in the field of application*