

# TRACKIT

HANGING SYSTEM  
COMPONENTS  
ACCESSORIES

## **SHOPKIT GROUP LIMITED**

100 Cecil Street · North Watford · Hertfordshire WD24 5AD · England

Tel: +44 (0)1923 818282 Fax: +44 (0)1923 818280 email: [sales@shopkit.com](mailto:sales@shopkit.com) web: [www.shopkit.com](http://www.shopkit.com)

## **SHOPKIT EXPORT LIMITED**

100 Cecil Street · North Watford · Hertfordshire WD24 5AD · England

Tel: +44 (0)1923 818282 Fax: +44 (0)1923 818280 email: [export@shopkit.com](mailto:export@shopkit.com) web: [www.shopkit.com](http://www.shopkit.com)

## **SHOPKIT GmbH**

Adler Str. 9 · 40211 Düsseldorf · Germany

Fon: +49(0)211/38 69 6-0 Fax: +49(0)211/38 69 6-24 email: [info@shopkit.de](mailto:info@shopkit.de) web: [www.shopkit.de](http://www.shopkit.de)



# TRACKKIT

HANGING SYSTEMS  
COMPONENTS  
ACCESSORIES

TRACK

MINI CABLE

6MM ROD

8MM DROP ROD

SINGLE ROLLER WHEEL

TWIN ROLLER WHEEL

STRAP

TRAC

**KIT**

TracKit – a versatile track system, wall or ceiling fixed, giving mobility and flexibility to the presentation of graphics, pictures and products.

TracKit offers a choice of suspension methods, firstly a simple hook-on system and secondly a roller wheel system which allows the re-positioning of graphics, pictures or panels by simply sliding the roller wheels along the track.

TracKit is available wall or ceiling fixed with a choice of single or twin tracks, enabling the design of multi-track installations – giving window displays the potential for depth and flexibility. TracKit is supplied in a satin anodised aluminium finish with a 32mm x 9.5mm cross section which should only be used with the 1.5mm Mini Cable system, the 6mm Aluminium Rod system, and the Double Roller Wheel system.

For heavier displays TracKit offers a brushed stainless steel track with a 40mm x 10mm cross section. This track is to be used with the 8mm stainless steel Drop Rod system, the Single Roller Wheel system and the Strap merchandising system.

Shopkit will advise on the suitability of which track to use related to specific requirements and should be consulted prior to ordering.



Shopkit offers a choice of six systems that are compatible with TracKit; 1.5mm Mini Cable, 6mm Aluminium Rod, 8mm Stainless Steel Drop Rod, Single Roller Wheel, Double Roller Wheel, and the Strap Merchandising System.

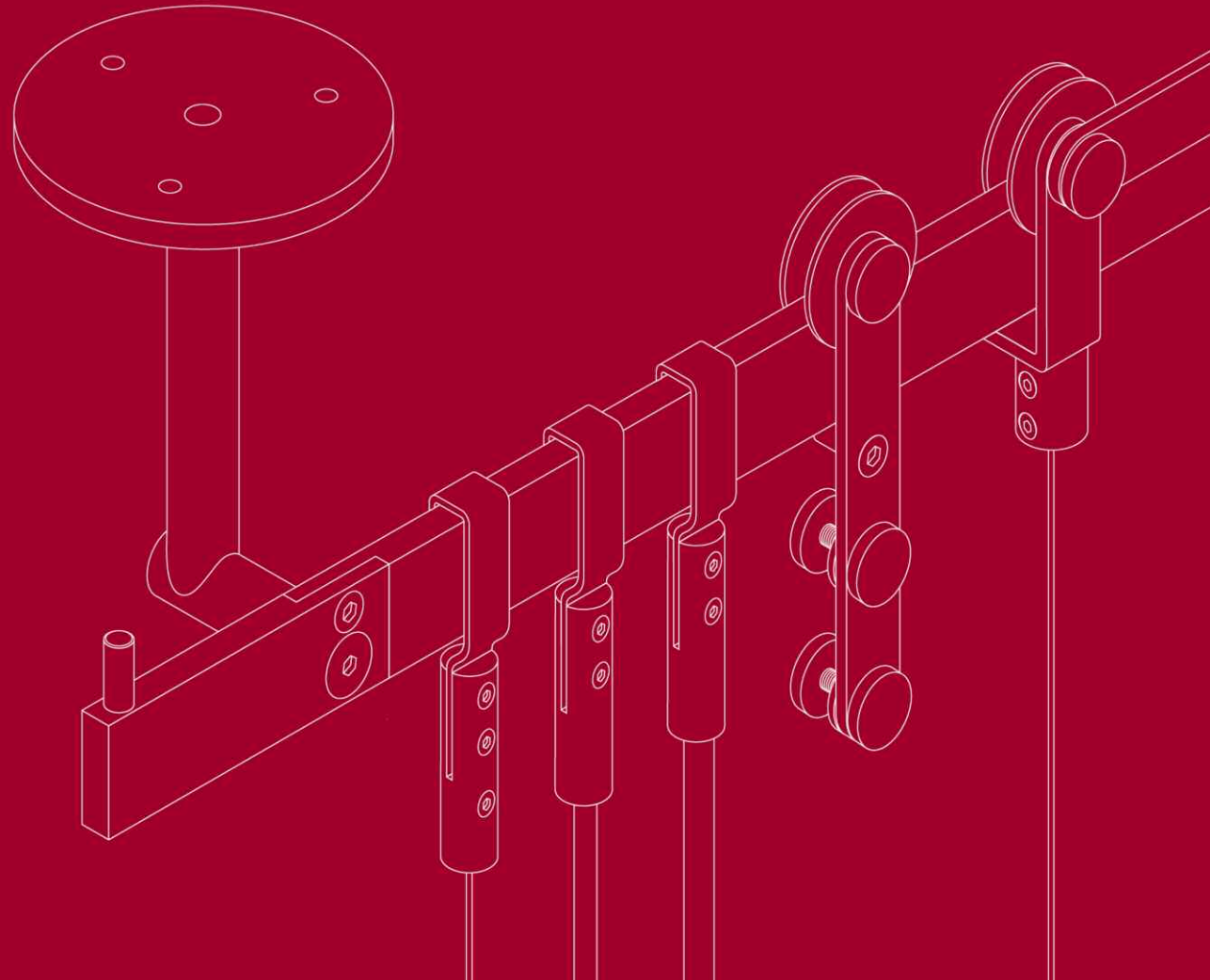

# TRACKIT

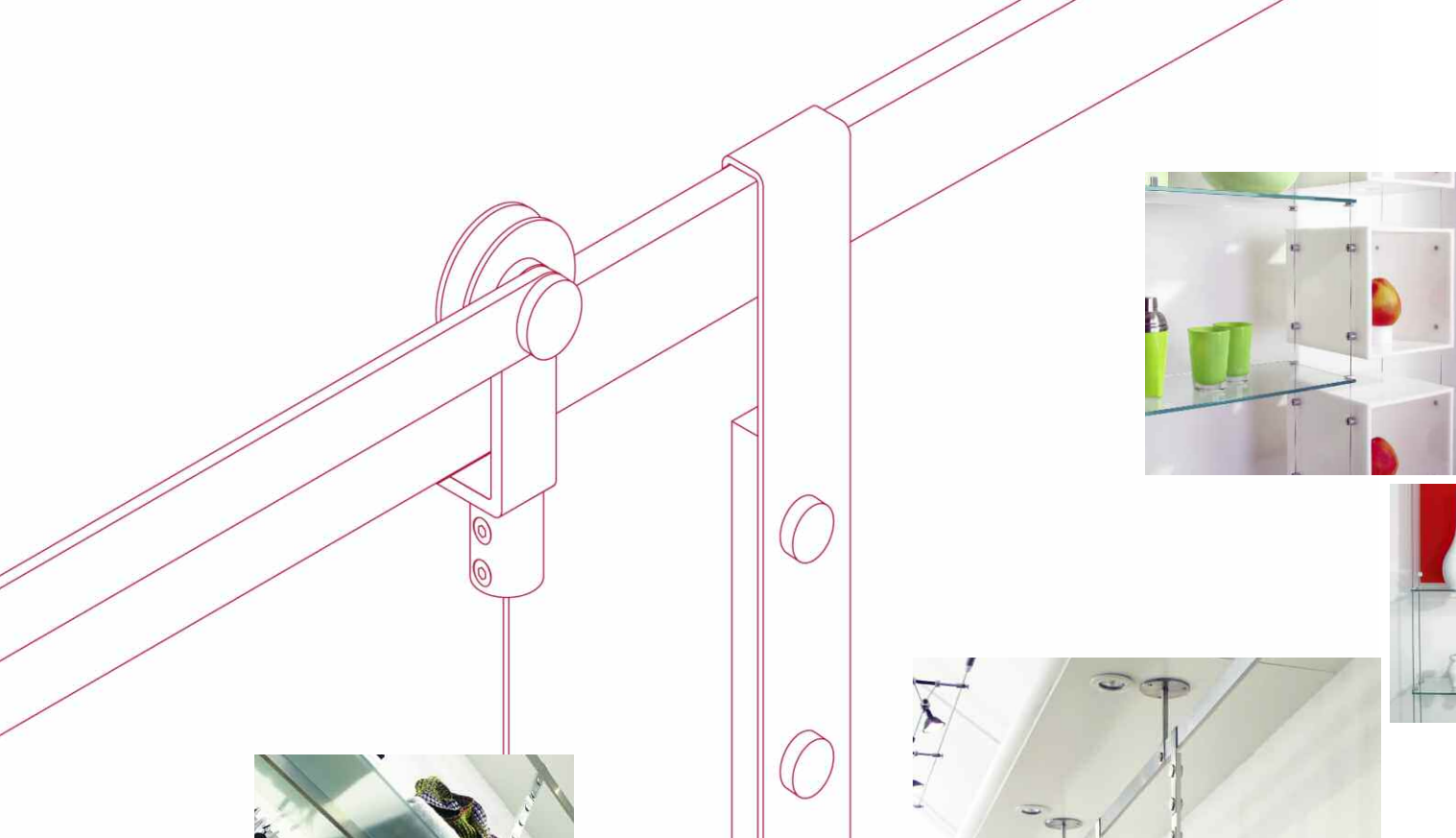

- 2** Track
- 10** Mini Cable
- 16** 6mm Rod
- 22** 8mm Drop Rod
- 28** Single Roller Wheel
- 32** Twin Roller Wheel
- 36** Strap



# TrackKit



Aluminium TrackKit – is a 32mm x 9.5mm satin anodised aluminium section comprising a main modular track length of 1030mm which when connected gives spacing between supports of one meter. To complete the run of track there is a left and right hand end module with a removable end stop. This allows the Single and Double Roller Wheel systems to be located without disassembly. Only the 1.5mm Mini Cable system, the 6mm Aluminium Rod system, and the Double Roller Wheel system should be used on this track.

Stainless Steel TrackKit – is a 40mm x 10mm brushed stainless steel section supplied in exactly the same modules as the aluminium track. This track is heavy duty track and is suitable for use with the 8mm Stainless Steel Drop Rod system, the Single Roller Wheel system, and the Strap Merchandising system.



# TrackKit Components

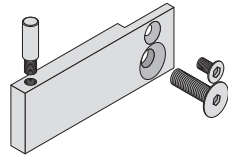

**Left Hand Track End**  
TK.1.A

Left hand track end module with removable end stop. Satin anodised aluminium 32mm x 9.5mm section.

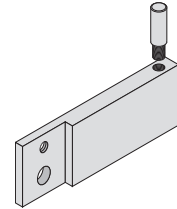

**Right Hand Track End**  
TK.2.A

Right hand track end module with removable end stop. Satin anodised aluminium 32mm x 9.5mm section.

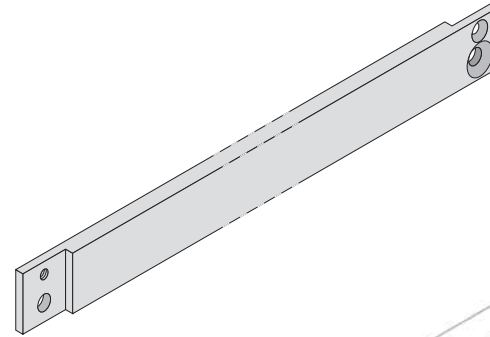

**Track Module**  
TK.3.A

Main track module 1030mm overall with connections at 1000mm. Satin anodised aluminium 32mm x 9.5mm section.

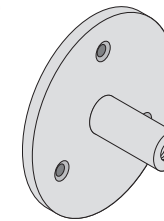

**Wall Fixed Bracket**  
TK.4

Wall fixed bracket for TrackKit. Positions track 50mm to the centre from the wall, 60mm diameter fixing disc. Brushed stainless steel finish.

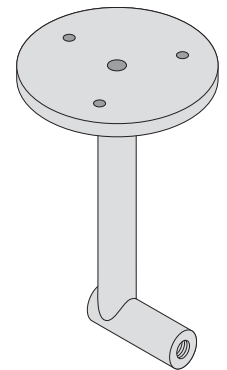

**Single Sided Ceiling Fixed Bracket**  
TK.5

Ceiling fixed bracket for single run of track. Positions track 114mm to the top edge from the ceiling. Brushed stainless steel finish.

**Heavy Duty Left Hand Track End**  
TK.1.SS

Left hand track end module. Brushed stainless steel 40mm x 10mm section. Can be used with all hook on or Roller Wheel systems.

**Heavy Duty Right Hand Track End**  
TK.2.SS

Right hand track end module. Brushed stainless steel 40mm x 10mm section. Can be used with all hook on or Roller Wheel systems.

**Heavy Duty Track Module**  
TK.3.SS

Main track module 1030mm overall with connections at 1000mm. Brushed stainless steel 40mm x 10mm section.

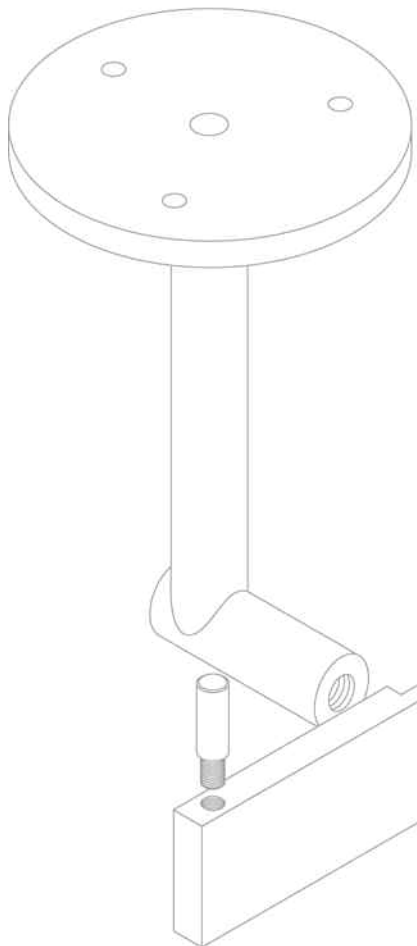

# TrackIt

## Components

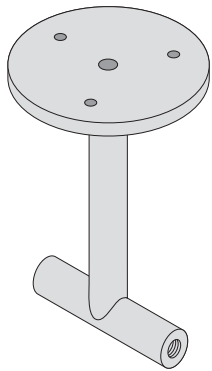

**100mm Double Sided  
Ceiling Fixed Bracket**  
TK.6

Ceiling fixed bracket for twin run of track at 100mm centres. Positions track 114mm to the top edge from the ceiling. Brushed stainless steel finish.

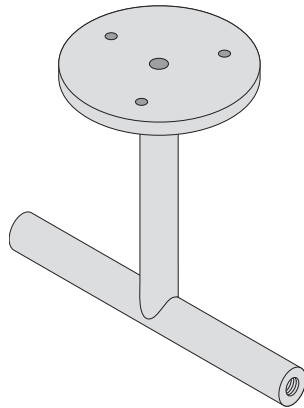

**200mm Double Sided  
Ceiling Fixed Bracket**  
TK.7

Ceiling fixed bracket for twin run of track at 200mm centres. Positions track 114mm to the top edge from the ceiling. Brushed stainless steel finish.

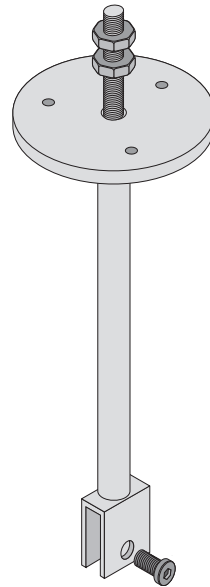

**Heavy Duty Bracket  
for Unistrut Fixing**  
TK.8

Ceiling fixed bracket (to support stainless steel track only) for fixing to unistrut. This is supplied with a 1m length of M10 stud bar welded to the top of the track support. A cover tube and disc is supplied in brushed stainless steel which drops over the 10mm stud bar. The top of the track is positioned 114mm from finished ceiling. This support system is to be used with the Strap Merchandising system. All other systems can use this method of support with the exception of Single and Double Roller Wheel.

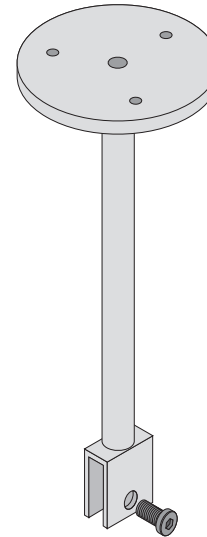

**Heavy Duty Bracket  
for Ceiling Fixing**  
TK.9

Ceiling fixed bracket (to support stainless steel track only) for fixing directly to a concrete ceiling or ceiling suitably reinforced to carry the displays or merchandise it is required to support. The top of the track is positioned 114mm from finished ceiling. This support system is to be used with the Strap Merchandising system. All other systems can use this method of support with the exception of Single and Double Roller Wheel.

Both the aluminium TrackIt and stainless steel TrackIt can be wall or ceiling fixed. The range of wall and ceiling brackets are manufactured from brushed stainless steel and comprise: wall fixing plate, ceiling fixing plate for single track, ceiling fixing plate for twin track at 100mm centres, ceiling fixing plate for twin track at 200mm centres and a heavy duty fixing plate for fixing to unistrut, concrete, or a reinforced ceiling. The Strap merchandising system can only be supported off this heavy duty fixing plate.

Always consult Shopkit prior to ordering to discuss the correct component combination. The suitability of walls and ceilings to carry suspended loads is the responsibility of the client.

# TrackKit

## Setups

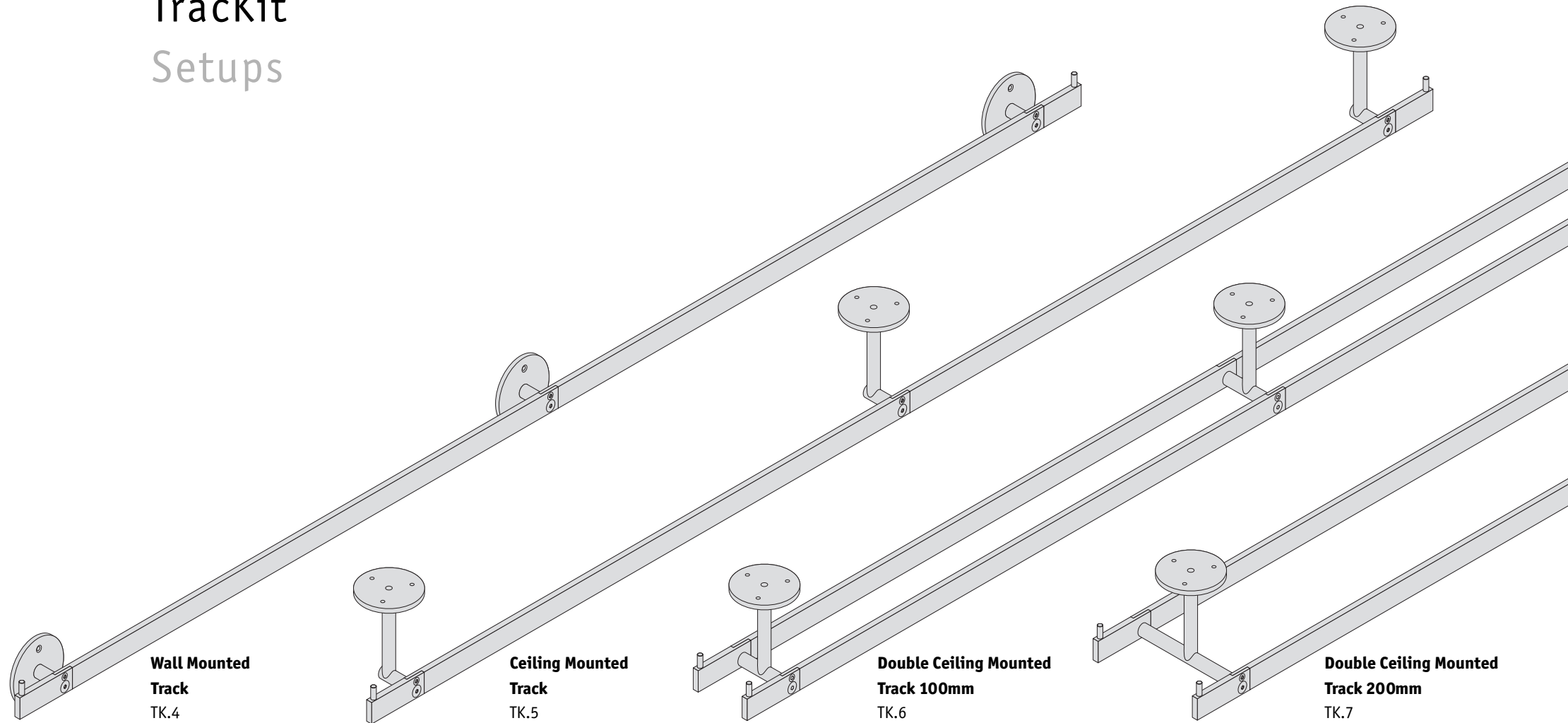

**Wall Mounted Track**  
TK.4

Wall fixed track using TK.4 brushed stainless steel fixing brackets. Spaced at 1000mm centres either the 38mm x 9.5mm satin anodised aluminium track or the heavy duty 40mm x 10mm stainless steel can be used. The 1.5mm Cable system, 6mm Rod system, and Twin Roller Wheel can be supported by this system using either the aluminium or stainless steel track.

**Ceiling Mounted Track**  
TK.5

Ceiling fixed single track using TK.5 brushed stainless steel fixing brackets spaced at 1000mm centres. Either the 38mm x 9.5mm satin anodised aluminium track or the heavy duty 40mm x 10mm stainless steel track can be used. The 1.5mm Cable system, 6mm Rod system, 8mm Drop Rod system and Twin Roller Wheel can be supported by this system using either the aluminium or stainless steel track.

**Double Ceiling Mounted Track 100mm**  
TK.6

Ceiling fixed twin track spaced at 100mm centres using TK.6 brushed stainless steel fixing brackets spaced at 1000mm centres. Either the 38mm x 9.5mm satin anodised aluminium track or the heavy duty 40mm x 10mm stainless steel track can be used. The 1.5mm Cable system, 6mm Rod system, 8mm Drop Rod system, Roller Wheel and Twin Roller Wheel can be supported by this system using either the aluminium or stainless steel track

**Double Ceiling Mounted Track 200mm**  
TK.7

Ceiling fixed twin track spaced at 200mm centres using TK.7 brushed stainless steel fixing brackets spaced at 1000mm centres. Either the 38mm x 9.5mm satin anodised aluminium track or the heavy duty 40mm x 10mm stainless steel track can be used.

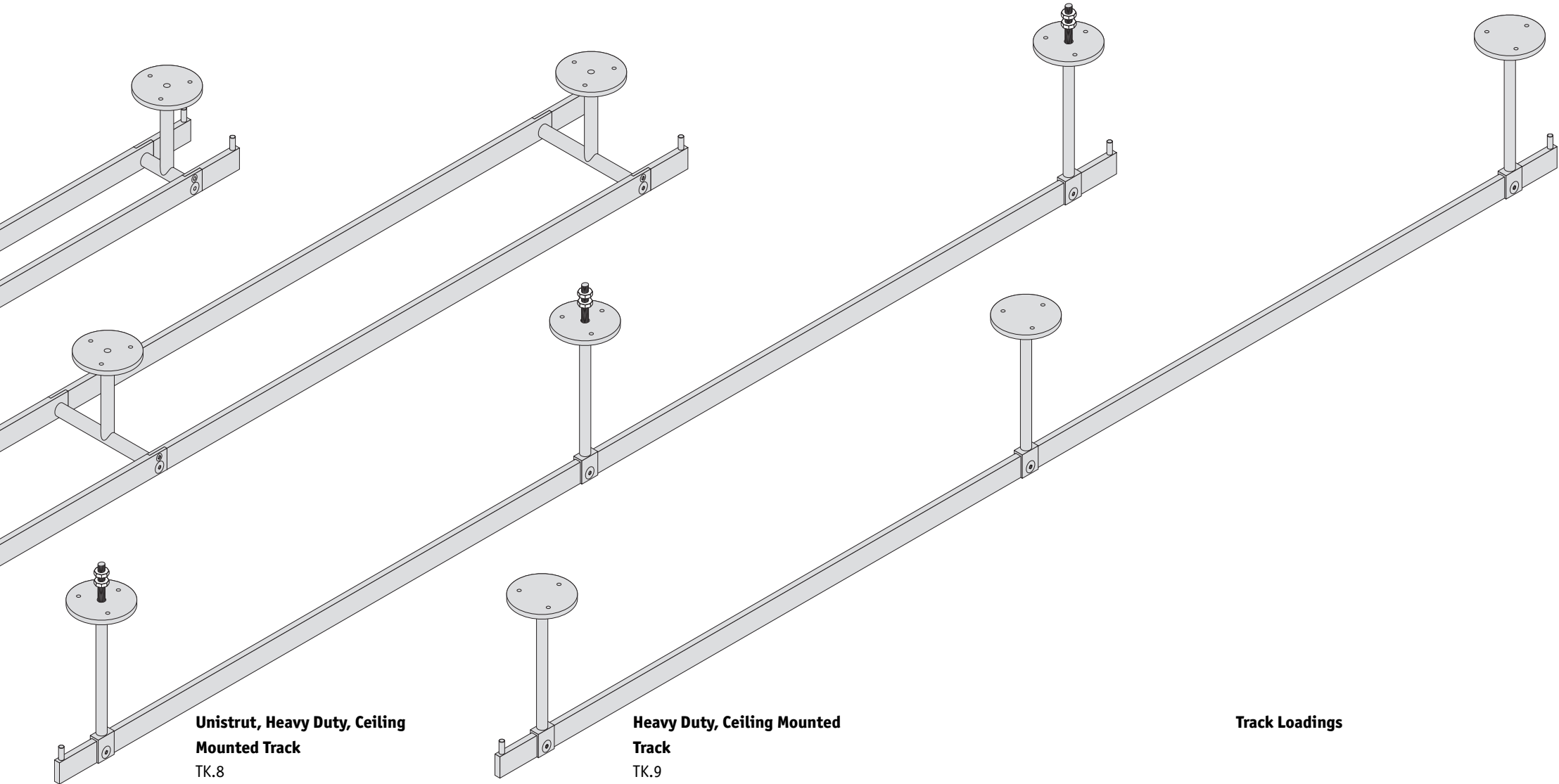

**Unistrut, Heavy Duty, Ceiling Mounted Track**  
TK.8

Ceiling fixed track using TK.8 brushed stainless steel bracket fixed through suspended ceiling and into unistrut. This track is only supplied in the heavy duty stainless steel 40mm x 10mm section. Fixings are at 1000mm centres. This system is for use with the Strap Merchandising system.

**Heavy Duty, Ceiling Mounted Track**  
TK.9

Ceiling fixed track using TK.9 brushed stainless steel bracket fixed to concrete or other suitable solid ceiling capable of supporting suspended loads. This track is only supplied in the heavy duty stainless steel 40mm x 10mm section. Fixings are at 1000mm centres. This system is for use with the Strap Merchandising system.

### Track Loadings

**The maximum weights per meter run of track are 15K.g for aluminium track and 25K.g for stainless steel track.**



TracKit



# Mini Cable

A well proven and adaptable system, capable of meeting most display requirements. The cable is secured by allen screws into a top hook which is easily positioned at any point along the TracKit system. To keep the cables taut, a polished stainless steel weight is offered which can be secured to the bottom of the cable.



# Mini Cable





# Mini Cable Components

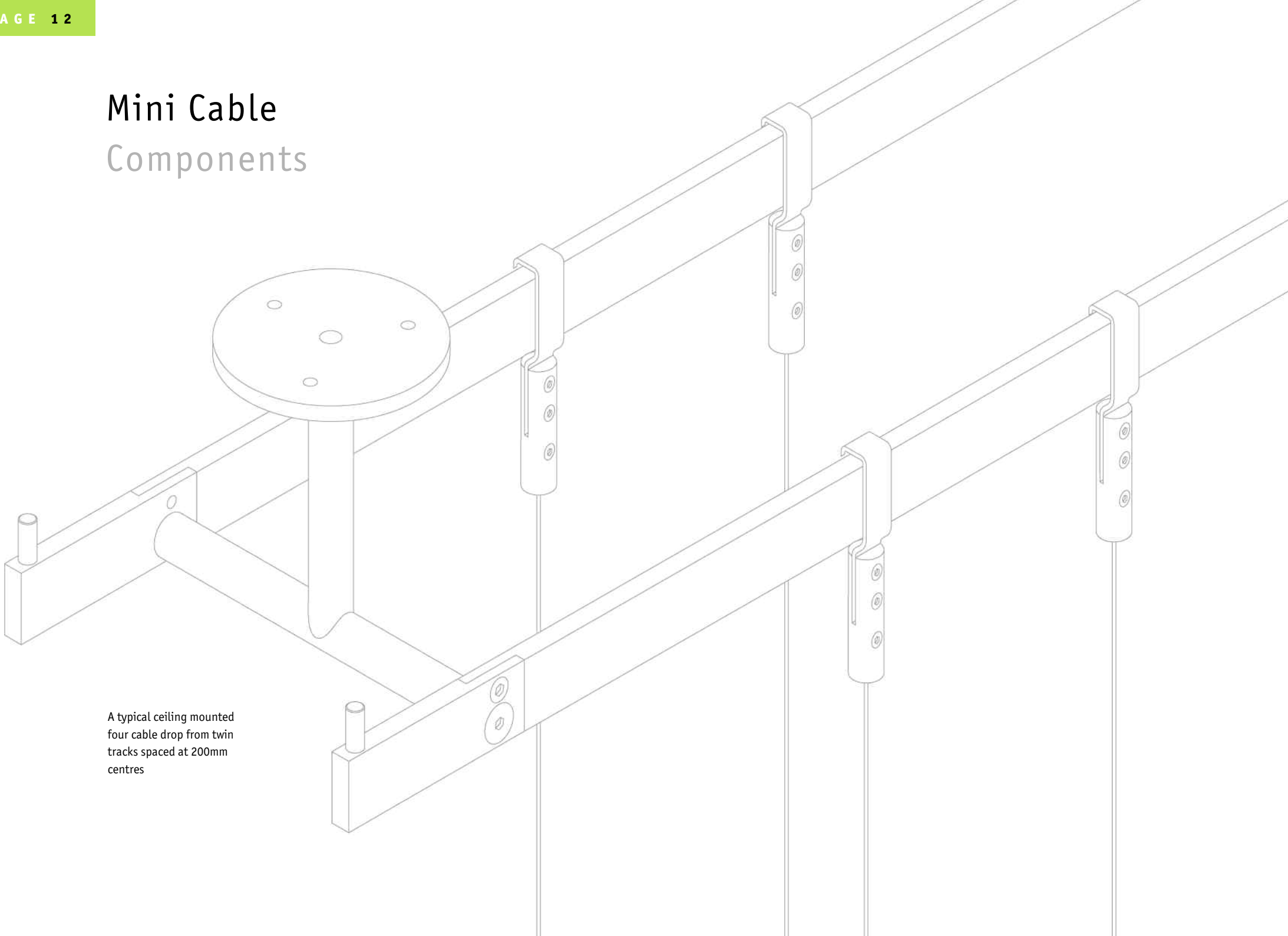

A typical ceiling mounted  
four cable drop from twin  
tracks spaced at 200mm  
centres

# Mini Cable Components

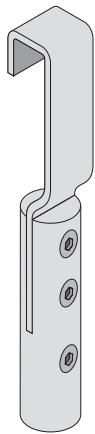

**Cable Top Hook**  
15.TH

Stainless steel track hook with satin anodised aluminium cable clamp.



**1.5mm Cable**  
15.6

1.5mm diameter stainless steel cable (sold by the meter) any length available.

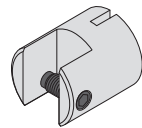

**Single Panel Grip**  
15.13

Satin anodised aluminium single panel grip takes up to 10mm thick panel.

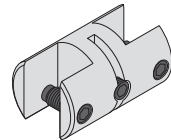

**Double Panel Grip**  
15.14

Satin anodised aluminium double panel grip takes up to 10mm thick panel.

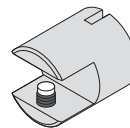

**Single Shelf Grip**  
15.18

Satin anodised aluminium single shelf grip takes up to 10mm thick shelf.

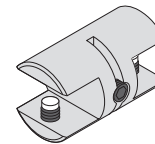

**Double Panel Grip**  
15.26

Satin anodised aluminium double shelf grip takes up to 10mm thick shelf.

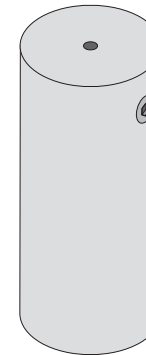

**Cable Base Weight**  
EW.01

Polished stainless steel weight 120mm long x 40mm diameter.

Shown in this section are the picture/panel grips and shelf grips. A wider range of cable accessories are available and can be viewed on the website [www.shopkit.com](http://www.shopkit.com) or a Shopkit brochure can be sent on request.

Shopkit also supplies a wide range of acrylic holders and display equipment with bespoke designs tailored to individual requirements.



# Mini Cable



## 6mm Rod

The Aluminium Rod system allows for a flexible display system showing a marginally more visible means of support than the cable system. Simply screw the top rod into the top hook and then add the one meter modular lengths as required.



# 6mm Rod

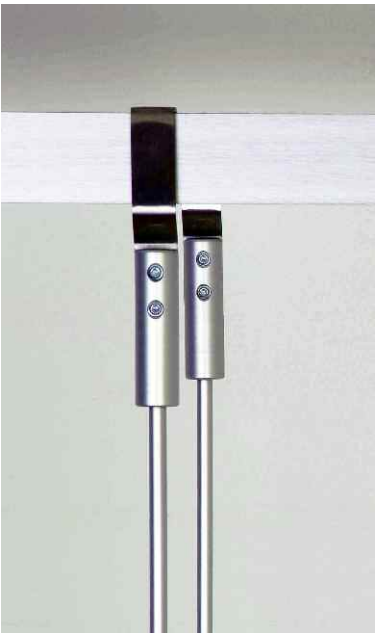

# 6mm Rod Components

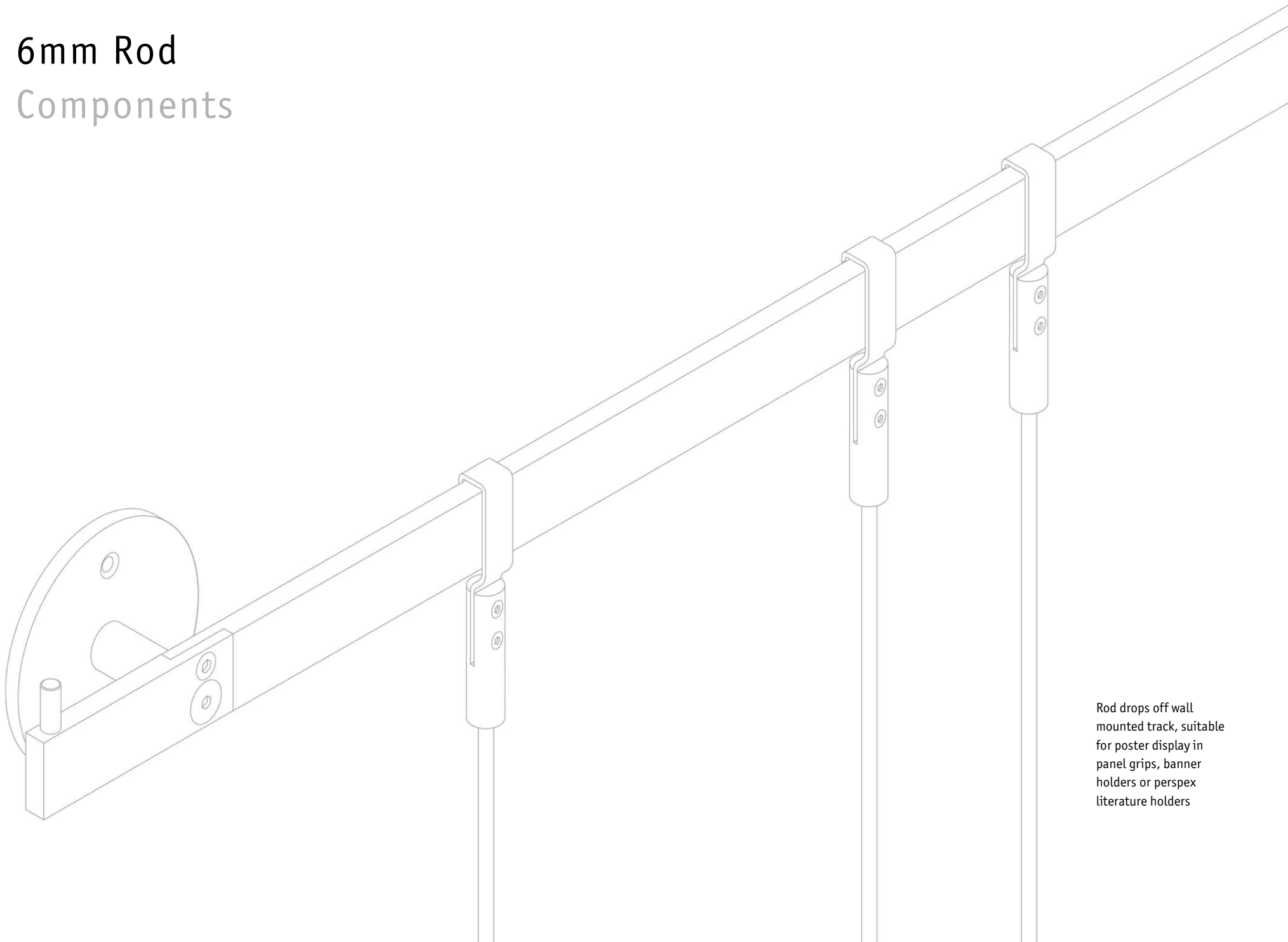

Rod drops off wall mounted track, suitable for poster display in panel grips, banner holders or perspex literature holders

# 6mm Rod Components

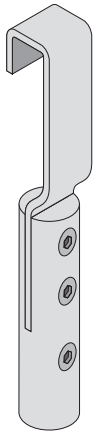

**Rod Top Hook**  
THR

Stainless steel track hook with satin anodised aluminium rod connector.



**Top Rod**  
R1.T.H

Satin anodised aluminium top rod, 6mm diameter – screws into track hook 1 meter long.



**Extension Rod**  
R1

Satin anodised aluminium rod, 6mm diameter extension pieces available in 1 meter lengths.

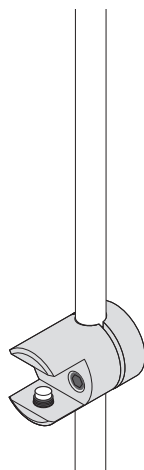

**Single Shelf Grip**  
R.4

Satin anodised aluminium single shelf grip takes up to 10mm thick shelf.

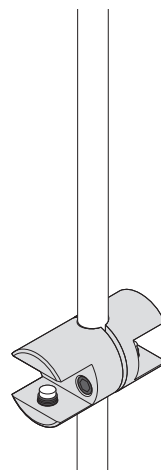

**Double Shelf Grip**  
R.5

Satin anodised aluminium double shelf grip takes up to 10mm thick shelf.

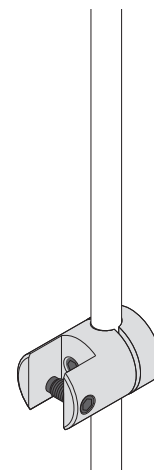

**Single Panel Grip**  
R.6

Satin anodised aluminium single panel grip takes up to 10mm thick panel.

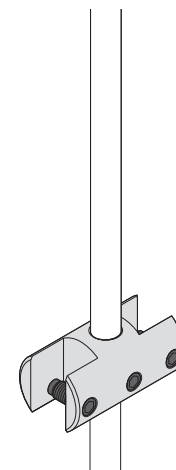

**Double Panel Grip**  
R.7

Satin anodised aluminium double panel grip takes up to 10mm thick panel.

Shown in this section are the picture/panel grips and shelf grips. A wider range of rod accessories are available and can be viewed on the website [www.shopkit.com](http://www.shopkit.com) or a Shopkit brochure can be sent on request.

Shopkit supplies a wide range of acrylic holders and display equipment with bespoke designs tailored to individual requirements.





6mm Rod



## 8mm Drop Rod

A strong and versatile display and merchandising system. Rod lengths are available in 500mm, 1000mm and 2000mm, any of which can be screwed into the top hook and then extended to the required drop by screwing one into the other. Unique to this system is the ability to suspend a display shelf off only two Drop Rods using the specially designed wide aluminium shelf grip. This method of supporting a shelf is both strong and safe but it is designed for use in display windows and not in public spaces. As with the cable and rod systems, Drop Rod can support panels, graphics, acrylics and shelves. Due to the finish and diameter of the stainless steel Drop Rods and the finely engineered aluminium accessories, this system brings quality and refinement to any display.



# 8mm Drop Rod

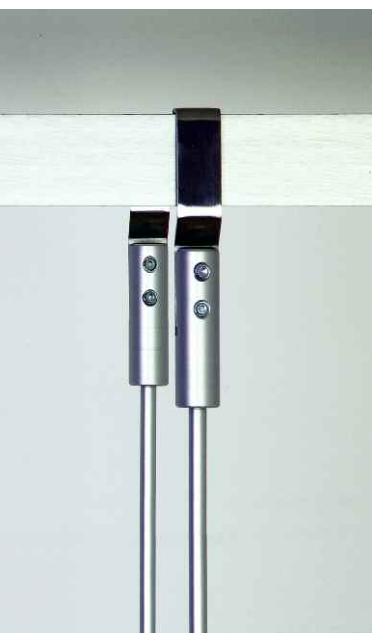

# 8mm Drop Rod

## Components

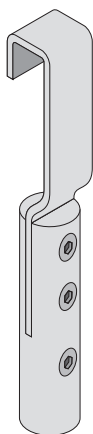

### Rod Track Hook

TH.DR

Stainless steel track hook with satin anodised aluminium rod connector.



### Drop Rod

DR1.500, 1000, 2000

500mm, 1000mm and 2000mm lengths of 8mm diameter brushed stainless steel rod. Male to female screw in connection.

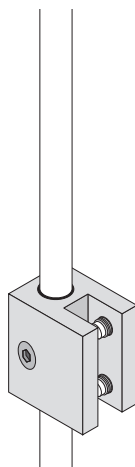

### Single-Sided Panel Grip

DR.3

Satin anodised aluminium single panel grip takes up to 8mm thick panel.

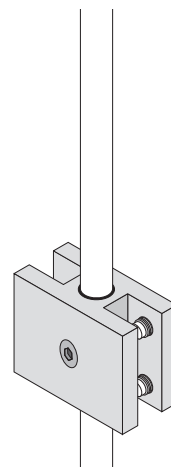

### Double-Sided Panel Grip

DR.4

Satin anodised aluminium double panel grip takes up to 8mm thick panel.

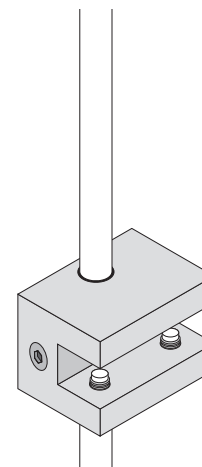

### Single-Sided Shelf Grip

DR.5

Satin anodised aluminium single shelf grip takes up to 10mm thick shelf.

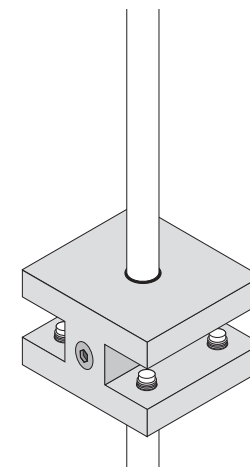

### Double-Sided Shelf Grip

DR.6

Satin anodised aluminium double shelf grip takes up to 10mm thick shelf.

# 8mm Drop Rod Components

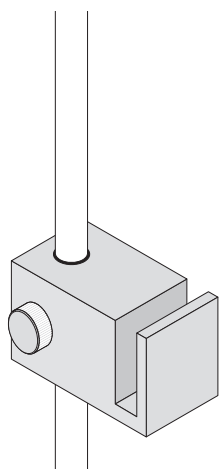

**Single-Sided  
Hook**  
DR.7

Satin anodised  
aluminium single  
display hook.

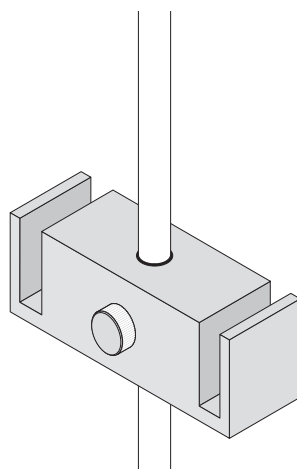

**Double-Sided  
Hook**  
DR.8

Satin anodised  
aluminium double  
display hook.

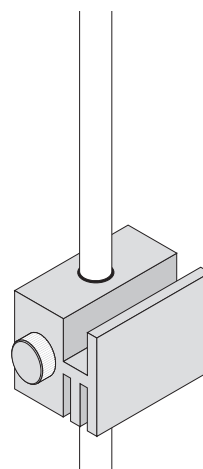

**Single-Sided Easy  
Access Acrylic Support**  
DR.9

Satin anodised aluminium  
inline support single sided.

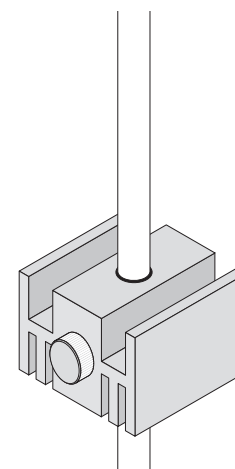

**Double-Sided Easy  
Access Acrylic Support**  
DR.10

Satin anodised aluminium  
inline support double sided.

A new range of aluminium panel grips, panel supports, shelf grips and hooks for the Drop Rod system incorporating a 'tool free' locking mechanism.



# 8mm Drop Rod





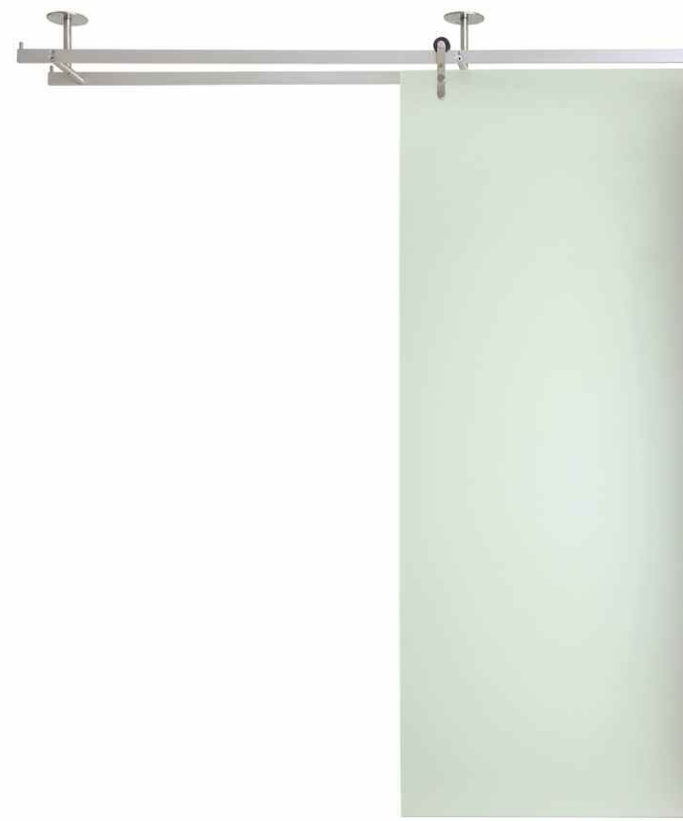

# Single Roller Wheel



# Single Roller Wheel

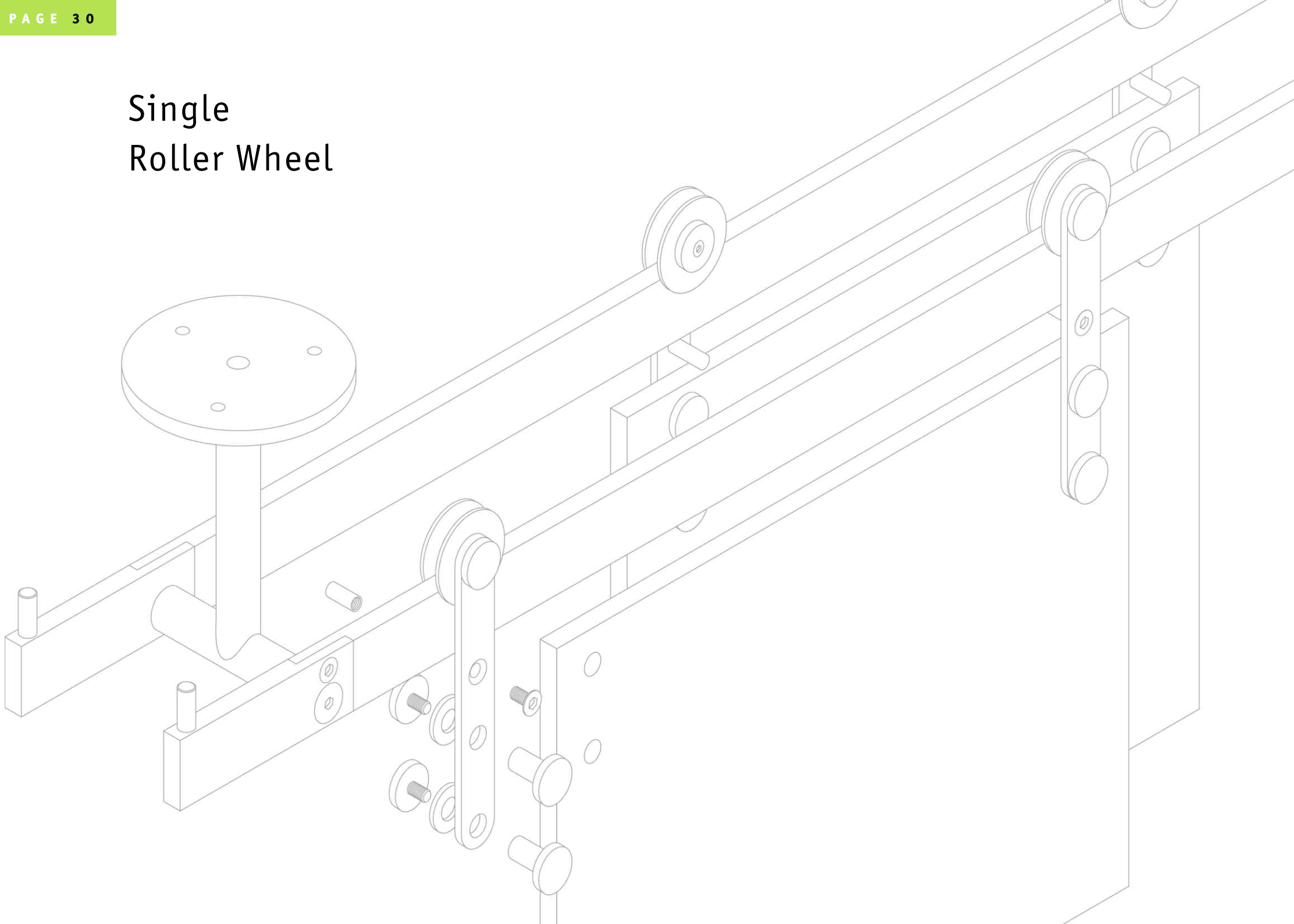

# Single Roller Wheel

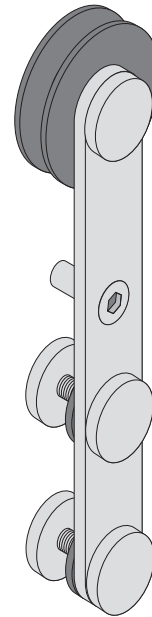

## Single Roller Wheel

SRW.1

Black nylon Roller Wheel with brushed stainless steel buttons and strap to support suspended panels up to 15mm thick and glass up to 10mm thick. To be used only with stainless steel track Ref: TK.3/SS.

The Roller Wheel allows the suspension of panels up to 15mm thick. Panels can be timber, glass, acrylic, and while there is no specific size restriction we would recommend a Roller Wheel at one meter centres and that any panel weight over the one meter span should not exceed 25 kilos. Larger Roller Wheels and track can be supplied, and detailed to requirements. The Single Roller Wheel can be used on the wall mounted track and the twin ceiling and single ceiling fixed tracks. This system is extremely flexible and allows panels to be stacked one behind the other and easily manoeuvred into any position required. An ideal system for galleries and window displays where the use of large graphic panels is required. Single Roller Wheel should be used in conjunction with the 40mm x 10mm brushed stainless steel track unless the weights of panels suspended do not exceed 15 kilos.



# Roller Wheel





# Twin Roller Wheel

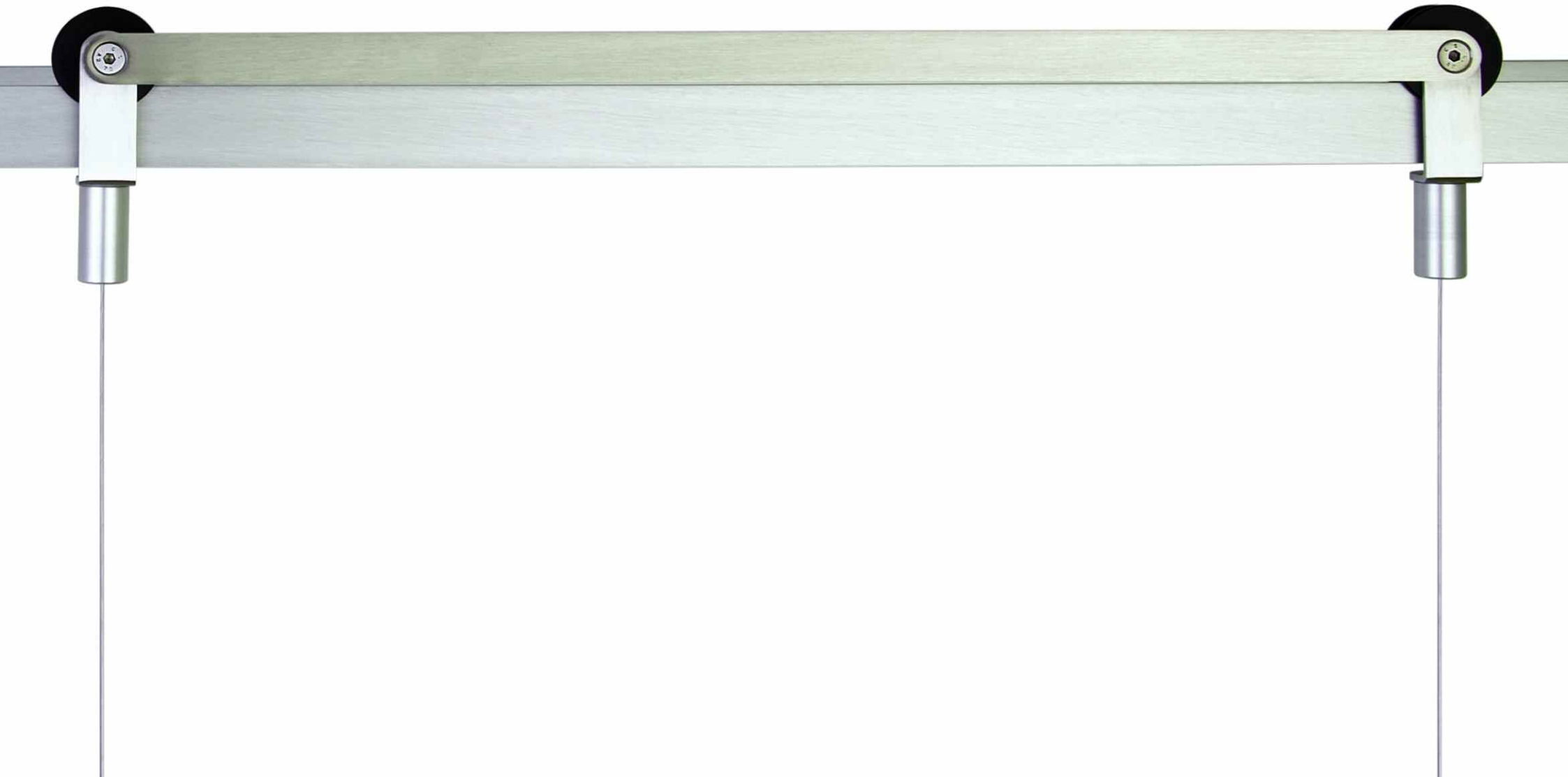



# Twin Roller Wheel

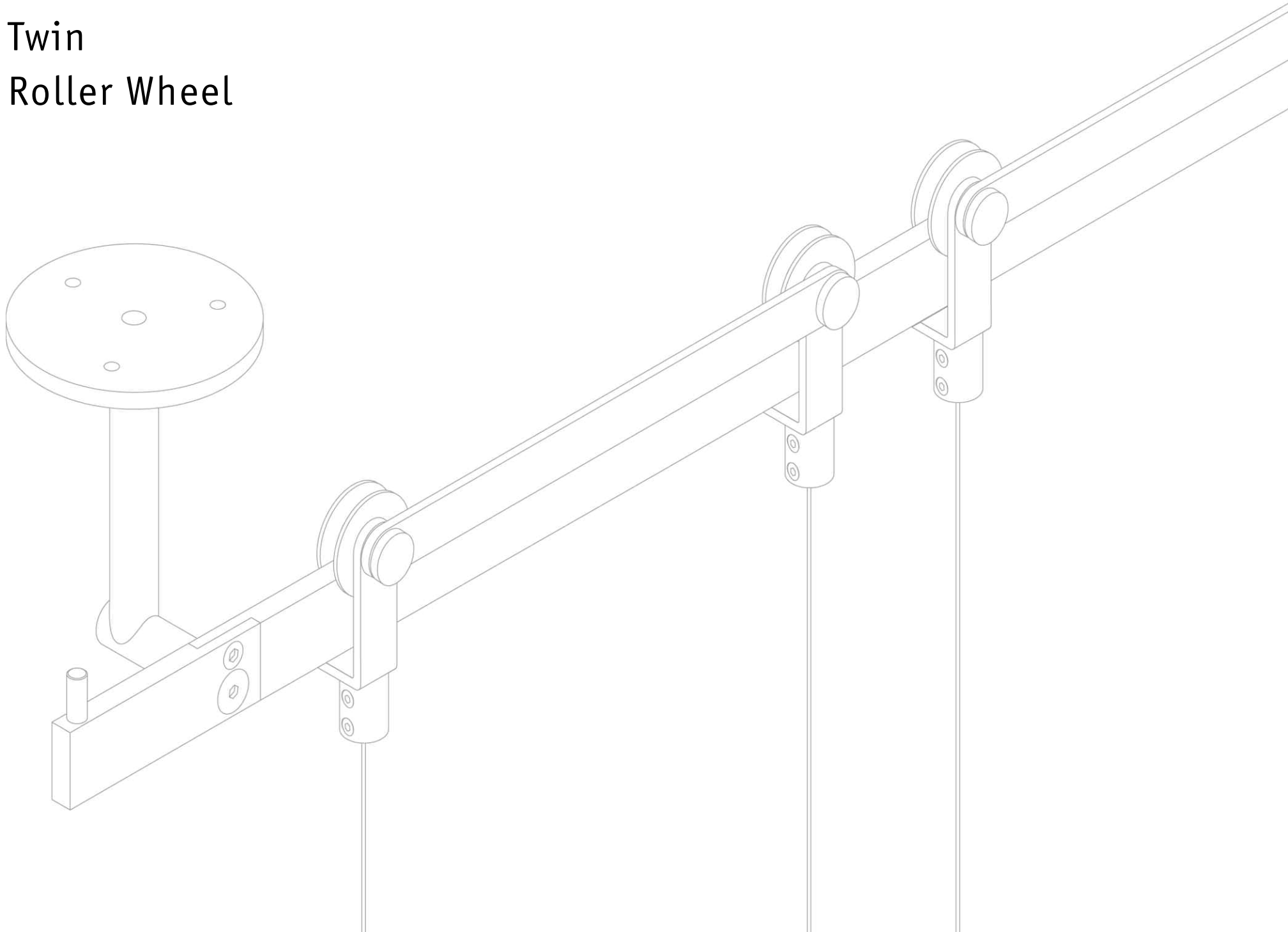

# Twin Roller Wheel

This system offers two standard widths of Roller Wheel, 246mm and 630mm. 1.5mm cables are gripped by allen screws directly under each Roller Wheel. If required the cables can be kept taut by using polished stainless steel weights. Acrylic panels and pictures can be supported from the top, the side, or hung one under the other. Flexibility and the ease of re-positioning graphic displays is the key feature of this system and by using the twin track system or a number of them together, depth and interest can be created to any display. Double Roller Wheel can be used on the single wall mounted track as well as the single and twin track ceiling fixed systems. This system is designed for suspending relatively light weight graphics or panels as they are generally gripped from the side or top by tightening allen screws. There are alternative ways of securing heavier panels and Shopkit will be happy to advise.

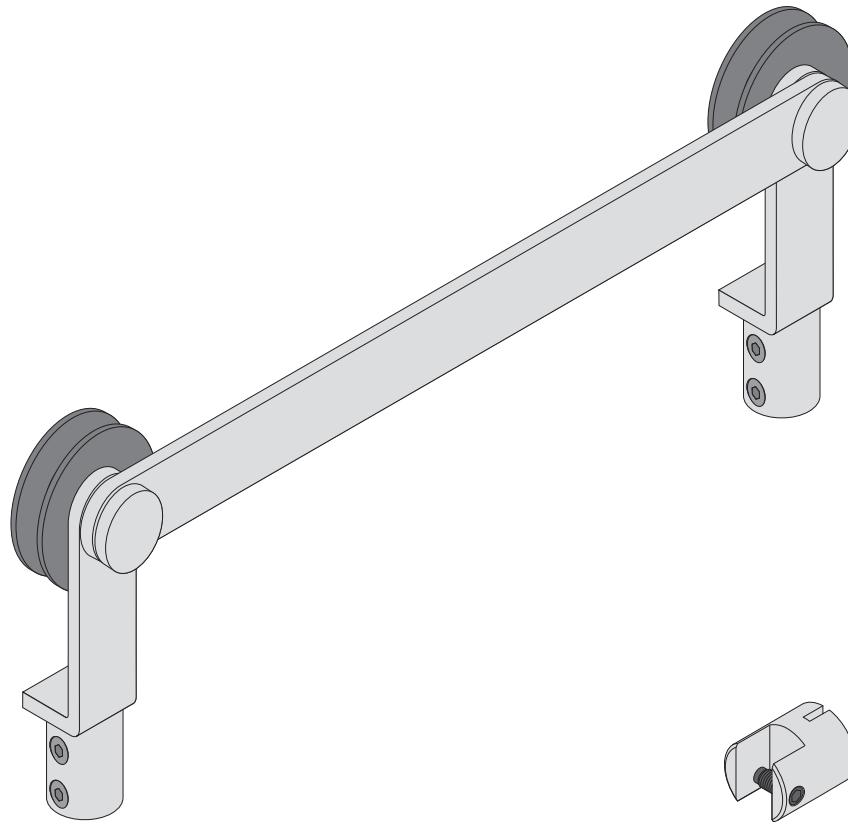

## Double Roller Wheel DRW.246

Double black nylon Roller Wheels connected by brushed stainless steel bar. Satin anodised aluminium cable clamps.

Distance between cables 246mm (takes A4 easy access acrylic)

## Double Roller Wheel DRW.630

Double black nylon Roller Wheels connected by brushed stainless steel bar. Satin anodised aluminium cable clamps.

Distance between cables 630mm (takes A1 easy access acrylic)

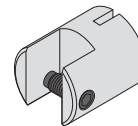

## Side Panel Grip 15.13

Satin anodised aluminium single sided panel grip takes up to 10mm thick panel.

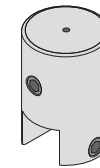

## Top Panel Grip 15.20

Satin anodised aluminium top edge grip takes up to 10mm thick panel.



# Twin Roller Wheel



# Strap

A completely unique concept for general merchandising or clothing. Beautifully engineered aluminium and stainless steel combine to give an elegant grid onto which products or garments can be displayed. There is total flexibility for positioning or linking shelves or hanging rails. Graphic panels illustrating lifestyle or product details can be added to the grid. Strap is simply hooked over the 40mm x 10mm brushed stainless steel TrackKit system supported by the heavy duty ceiling brackets.

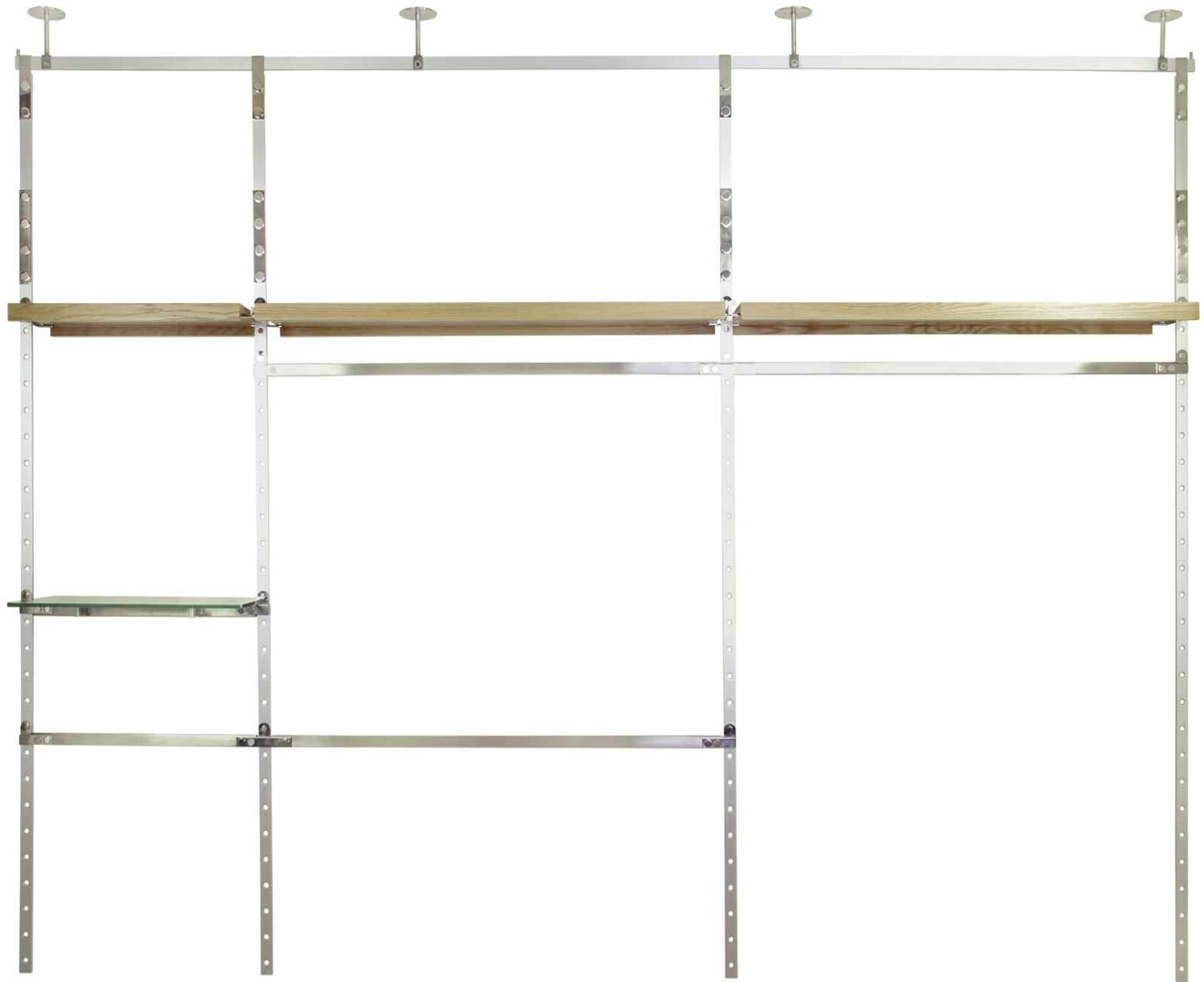

## Strap



Shopkit will advise on suitable components for fixing to the ceiling but the client or designer/architect is responsible for ensuring the suitability or design of the ceiling being fixed to, taking into account the likely suspended weights.

While Strap is designed to be ceiling fixed it can be positioned along the perimeter or form island merchandising at any point in a shop. The system comprises a mirror polished or brushed stainless steel top hook which connects to a plain 32mm x 9.5mm satin anodised flat linking strap. This strap can be manufactured to any required lengths up to 1800mm. The perforated aluminium strap is jointed to the plain strap using a bright polished or brushed stainless steel connector. This perforated strap is 1819mm long and has perforations every 65mm which accepts three types of lock-on brackets: a right hand single bracket, a left hand single bracket, and a two way linking bracket. The brackets are used to support hanging rails or shelf supports.

# Strap

## Components

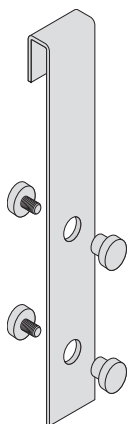

**Top Hook**  
ST.1

Bright polished or brushed stainless steel top hook. Includes screw fixings.



**Extension Strap**  
ST.2

Satin anodised aluminium blank extension strap manufactured to required length.

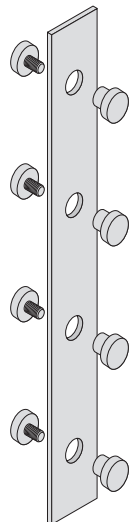

**Linking Strap**  
ST.3

Bright polished or brushed stainless steel connecting strap. Includes screw fixings.



**Merchandising Strap**  
ST.4

Satin anodised aluminium strap with 12mm diameter holes at 65mm centres supplied in standard length of 1819mm with 28 holes.

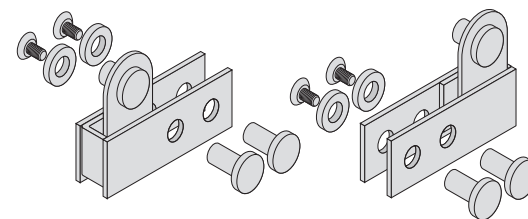

**Left Support**  
ST.6.L

Bright polished or brushed stainless steel single sided left hand bracket. Includes screw fixings.

**Right Support**  
ST.5.R

Bright polished or brushed stainless steel single sided right hand bracket. Includes screw fixings.

# Strap

## Components

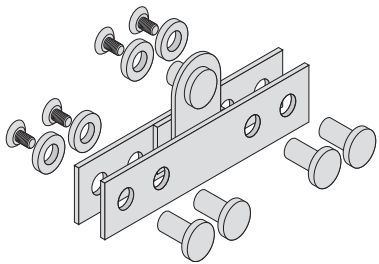

**Two-Way Support**  
ST.7.D

Bright polished or brushed stainless steel double sided support bracket. Includes screw fixings.

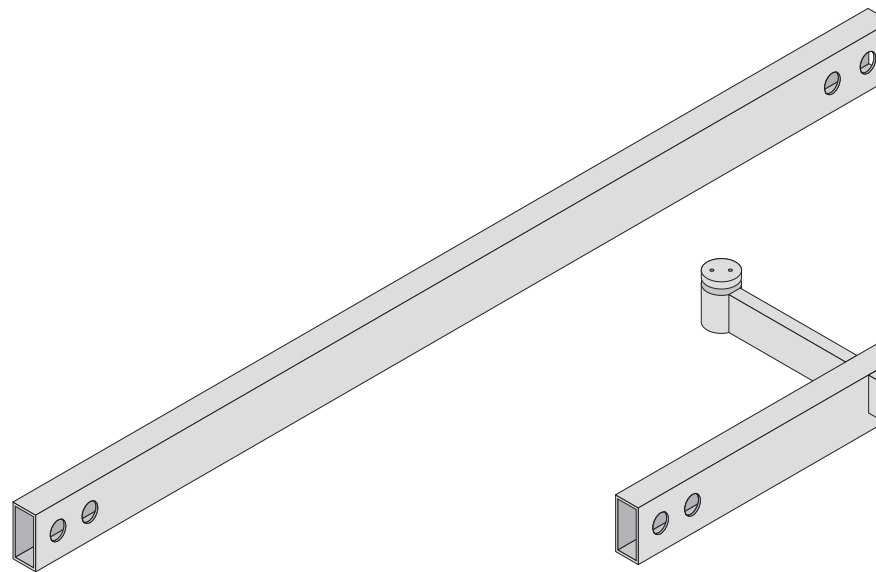

**Hanging Rail**  
ST.8 (603mm) ST.9 (1203mm)

603mm and 1203mm long brushed stainless steel hanging rail.

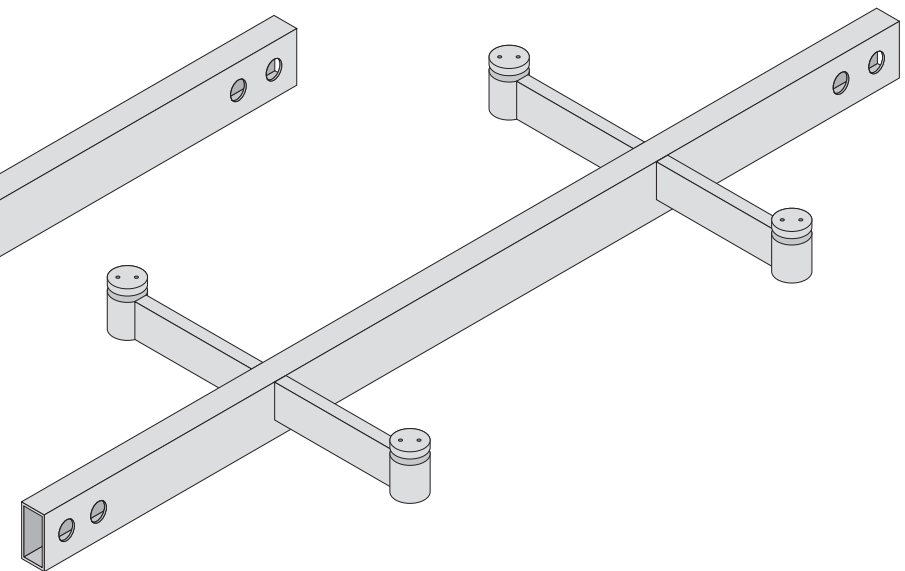

**Shelf Support**  
ST.10 (603mm) ST.11 (1203mm)

603mm and 1203mm long brushed stainless steel glass or timber shelf support.

Shopkit supplies a range of wood and glass shelves in a choice of sizes and finishes and is happy to consider individual requirements to ensure unique designs.





# Strap



TRAC

**KIT**