

Uniclass	EPIC
L384:D32	C441
CI/SfB	
32	(22.3) X



The Kompendium

Love the space you're in.

Komfort Workspace, our products, and you.

Our aim is to provide you, our customers with an unprecedented range of products and services.

"form ever follows function" - Louis Henry Sullivan

Every interior is unique. Its design has direct impact on individuals and the success of any business. This makes it so important to source the most compatible products for appearance, use of space and functionality.

We continue our on-going innovation in product design. Our partitions achieve high fire, acoustic and structural performance through stringent testing. This guarantees the safest and widest product offering for the UK's Commercial Interiors Sector. We ensure that all products are assembled and installed by professionals to the highest quality.

Whether for commercial, creative, administrative or industrial workplaces Komfort create a wealth of products to inspire harmony in any business environment.



Partitioning Performance Comparison Chart

This fold-out chart enables you to easily compare the performance specifications and options for each of our partitioning systems shown.

This page can be folded out and viewed next to each of the technical drawing double page spreads to give you an instant visual overview of each partitioning systems construction method and junction drawings alongside the relevant performance specifications.

For further technical specifications and technical drawing downloads visit

komfort.com

The Kompendium



Contents

600 Series	04
Kameo 75	14
Komfire 75	24
Komfire 100	34
Klassic	44
Ls90	54
Ls90 featuring Workwall	68
KM ³	72
Doors	84
Blinds & Graphics	100
Integral Blinds	102
Graphics	103
Manifestation	104
SwitchGlass	105
Polar Partitioning	106
Services	110
Partitioning Performance Comparison Chart	Inside Back Cover

Faceted single glazed 600 Series
partitioning using O posts to create
varying angles



600 Series

Komfort partitioning product comparison chart can be
found on the inside back cover of this brochure

trustworthy

Single glazed 600 Series
with banded manifestation

600 Series





Full height single glazed 600 Series
partitioning with standard height
glass door

600 Series

600 Series is an aluminium 50mm framed
system with vertical post variations for
height up to 6 metres

Technical spec at a glance

 **DIMENSIONS:**
Up to 6000mm high (subject to upright post)

 **FIRE RATINGS:**
N/A

 **ACOUSTICS:**
Solid - up to 31dB (Rw)
Double Glazed - up to 40dB (Rw)

 **STRUCTURE:**
Light duty

 **WEIGHT Per m² (kg):**
Solid up to 31.59
Glazed up to 35.22

 **BLINDS:**
Yes - integral

 **MANIFESTATION:**
Yes

Detailed 600 Series drawings can be found on
pages 12-13. In addition a partitioning product
comparison chart can be found on the inside
back cover of this brochure.

For further technical specifications and technical
drawing downloads go to - www.komfort.com

Full height glazed and solid 600 Series partitioning with doorframe, timber door and solid overpanel



Uncomplicated in design, 600 Series is slim line with a choice of crisp angular or soft radiused profiles. Through a little creativity it can evolve from a functional system, suiting most applications, to stamp its mark as a design statement.

600 Series



Freestanding 600 Series partitioning with glass door



135° posts to create a faceted corridor with solid and transom glazed partitioning



Single glazed 600 Series with vibrant banded manifestation

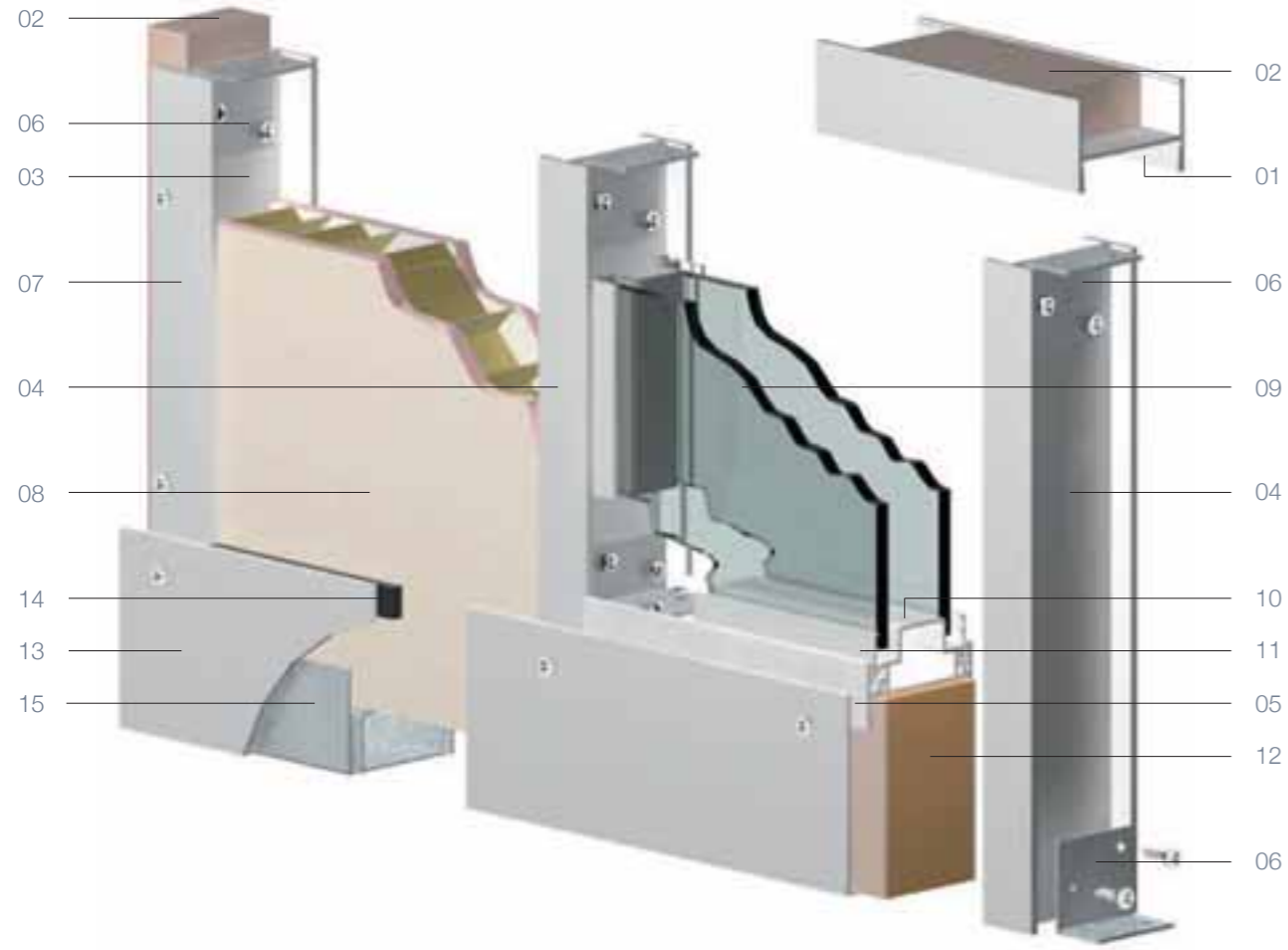

600 Series - 50mm partitioning system

- | | |
|--------------------|------------------------------|
| 01 Head channel | 09 6mm or 6.4mm safety glass |
| 02 Abutment seal | 10 Double glazing chair |
| 03 Break down post | 11 Glazing bead |
| 04 Upright post | 12 Flaxcore strip ground |
| 05 Transom | 13 75mm or 100mm skirting |
| 06 Fixing bracket | 14 Skirting foam seal |
| 07 Flat strip | 15 2 Part floor shoe |
| 08 46mm Kompanel | |

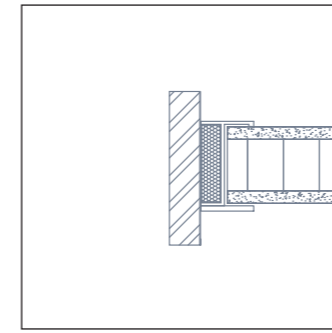

Solid abutment

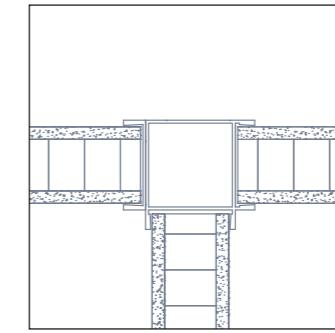

3 way solid junction

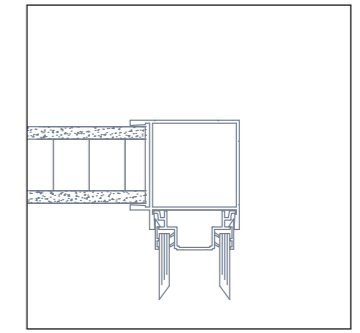

90° solid to glazed junction

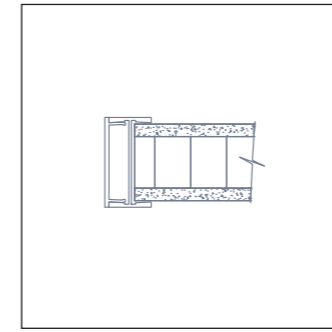

Solid fair end

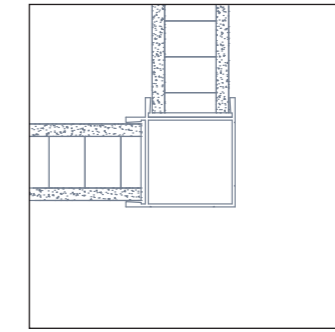

90° solid to solid junction

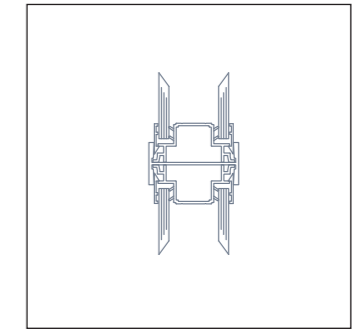

Glazed to glazed junction

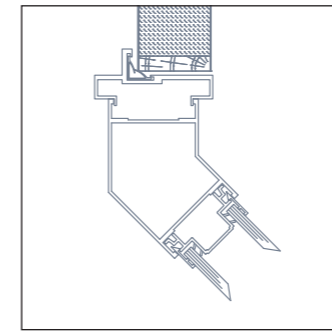

135° glazed to doorset junction

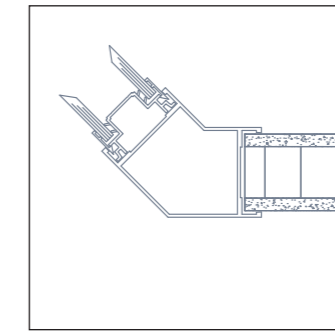

135° solid to glazed junction

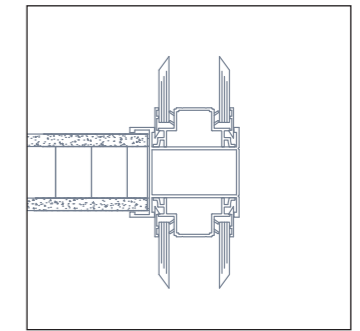

3 way glazed to solid to glazed junction

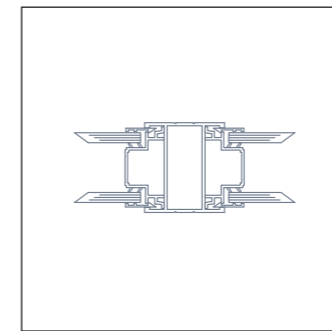

Alternative glazed to glazed junction

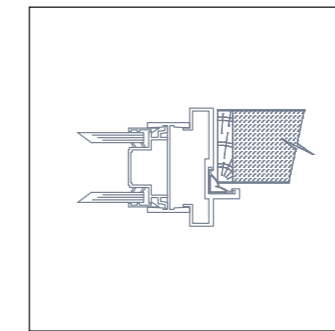

Glazed to doorset junction

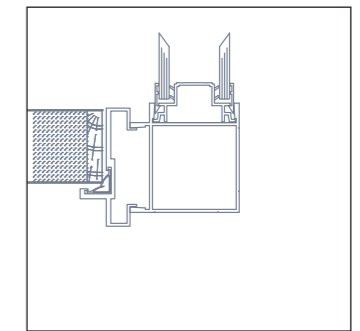

90° glazed to doorset junction

Komfort partitioning product comparison chart can be found on the inside back cover of this brochure

Solid and glazed Kameo 75 with signature radiused corners and integral blinds within the glazing



Kameo 75



Komfort partitioning product comparison chart can be found on the inside back cover of this brochure

accomplished

Solid and glazed Kameo 75
incorporating integral blinds
and veneered doors

Kameo 75



Full height Kameo 75
featuring Mirage gravity
hung panels

Kameo 75

Kameo 75 is a 75mm radius edge trim system in a steel stud and plasterboard construction with pre-assembled window frames

Technical spec at a glance

 **DIMENSIONS:**
Up to 4300mm (solid)

 **FIRE RATINGS:**
Up to 30/0

 **ACOUSTICS:**
Solid - up to 46dB (Rw)
Double Glazed - up to 41dB (Rw)

 **STRUCTURE:**
Up to medium duty

 **WEIGHT Per m² (kg):**
Solid up to 24.47
Glazed up to 39.04

 **BLINDS:**
Yes - integral

 **MANIFESTATION:**
Yes

Detailed Kameo 75 drawings can be found on pages 22-23. In addition a partitioning product comparison chart can be found on the inside back cover of this brochure.

For further technical specifications and technical drawing downloads go to - www.komfort.com

Full height solid and glazed Kameo 75 with signature radiused corners and banded manifestation to the glass

With its smooth and gently contoured form together with accomplished performance, Kameo 75 creates both serene and dynamic schemes.

Kameo 75



Full height solid and glazed Kameo 75 with full height veneered doors



Full height glazed Kameo 75 with integral blinds and Kameo 75 double doorframe featuring veneered doors



Solid and glazed Kameo 75 with signature radiused corners and integral blinds within the glazing creating individual offices

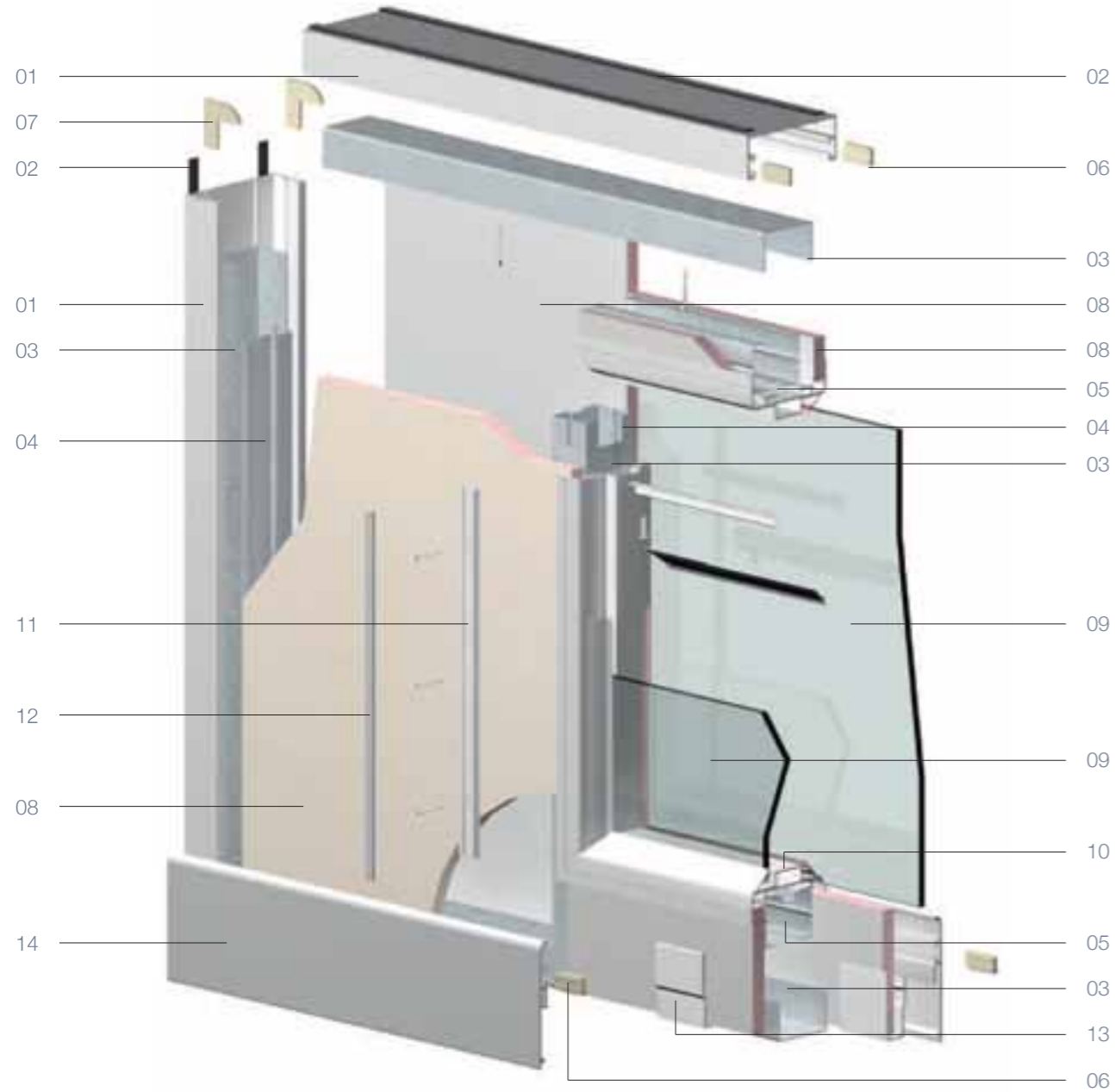

Kameo 75 - 75mm single skin partitioning system

- | | |
|----------------------------|---|
| 01 Head / abutment channel | 09 6mm/6.4mm safety glass or fire glass |
| 02 Abutment seal | 10 Pre-assembled window frame |
| 03 Steel head / base track | 11 Cover trim |
| 04 Steel vertical stud | 12 UPVc infill |
| 05 Steel stud transom | 13 Skirting clip |
| 06 Straight jointing cleat | 14 100mm skirting |
| 07 90° jointing cleat | |
| 08 12.5mm plasterboard | |

Note: For clarity the cavity infill has not been shown

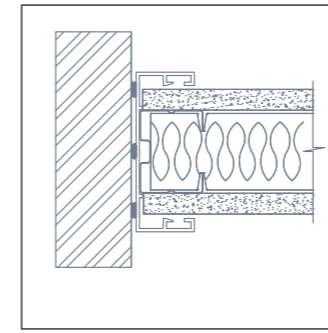

Solid abutment

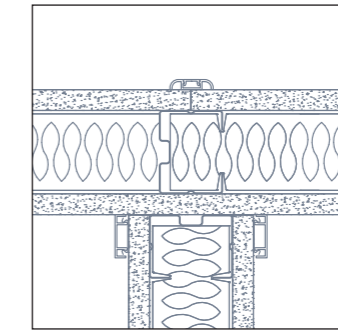

3 way solid junction

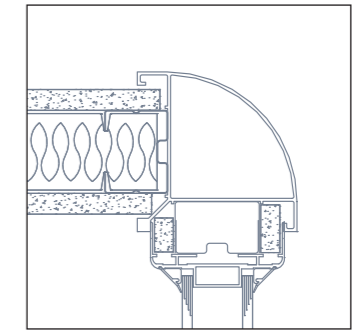

90° solid to glazed junction

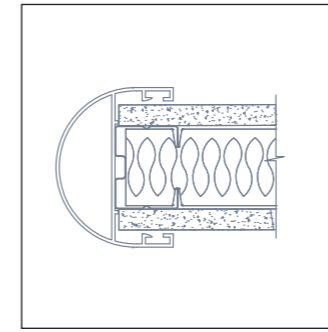

Solid fair end

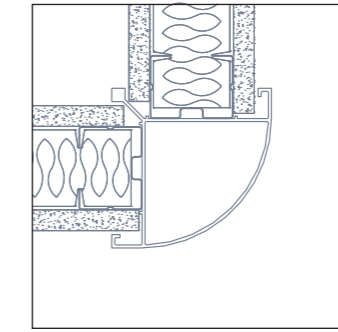

90° solid to solid junction

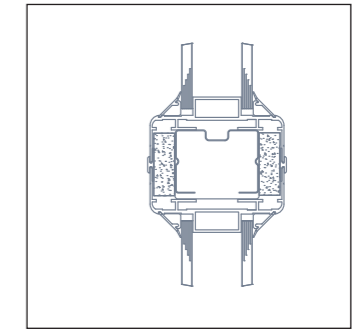

Glazed to glazed junction

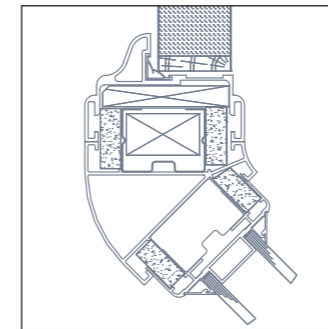

135° glazed to doorset junction

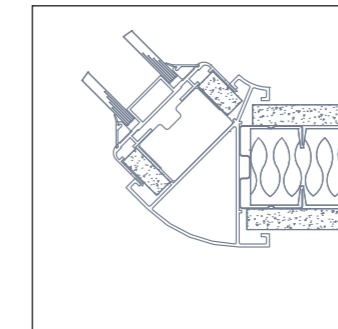

135° solid to glazed junction

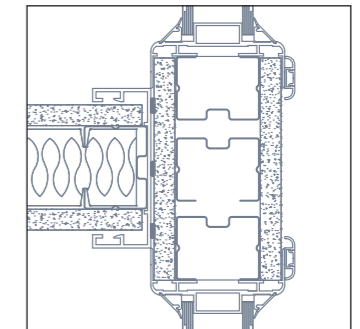

3 way glazed to solid to glazed junction

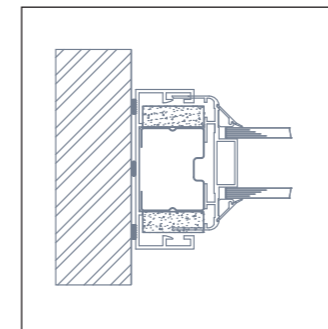

Glazed abutment

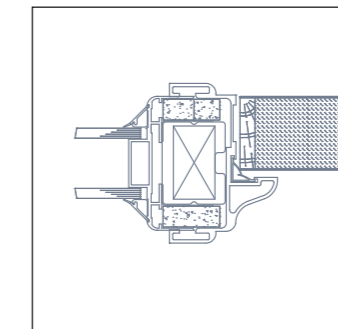

Glazed to doorset junction

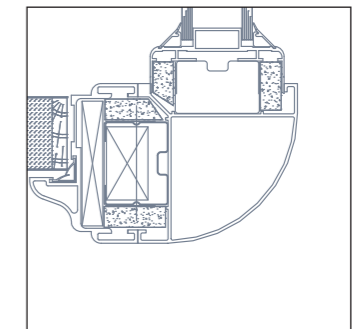

90° glazed to doorset junction

Full height faceted glazed
Komfire 75 with integral blinds



Komfire 75



Komfort partitioning product comparison chart can be found on the inside back cover of this brochure

supreme

Full height glazed Komfire 75 incorporating
integral blinds, doorframes, veneered doors
and porthole vision panels

Komfire 75



Full height solid Komfire 75 incorporating full height pre-assembled windows and veneered doors

Komfire 75

Komfire 75 is a 75mm square edge trim system in a steel stud and plasterboard construction with pre-assembled window frames

Technical spec at a glance

 **DIMENSIONS:**
Up to 4300mm (Solid)

 **FIRE RATINGS:**
Up to 30/0

 **ACOUSTICS:**
Solid - up to 43dB (Rw)
Double Glazed - up to 41dB (Rw)

 **STRUCTURE:**
Up to medium duty

 **WEIGHT Per m² (kg):**
Solid up to 24.47
Glazed up to 39.04

 **BLINDS:**
Yes - integral

 **MANIFESTATION:**
Yes

Detailed Komfire 75 drawings can be found on pages 32-33. In addition a partitioning product comparison chart can be found on the inside back cover of this brochure.

For further technical specifications and technical drawing downloads go to - www.komfort.com

Full height glazed and solid Komfire 75 with bespoke manifestation



Durable and simple to maintain and install, Komfire 75 sets the standards of partition form and function. That is why it is the UK's most popular partitioning system.

Komfire 75



Glazed Komfire 75 incorporating integral blinds and veneered door with Part M compliant vision panel



Full height solid Komfire 75 with standard height glazing and doors



Full height solid and glazed Komfire 75 incorporating banded manifestation with standard height veneered doors

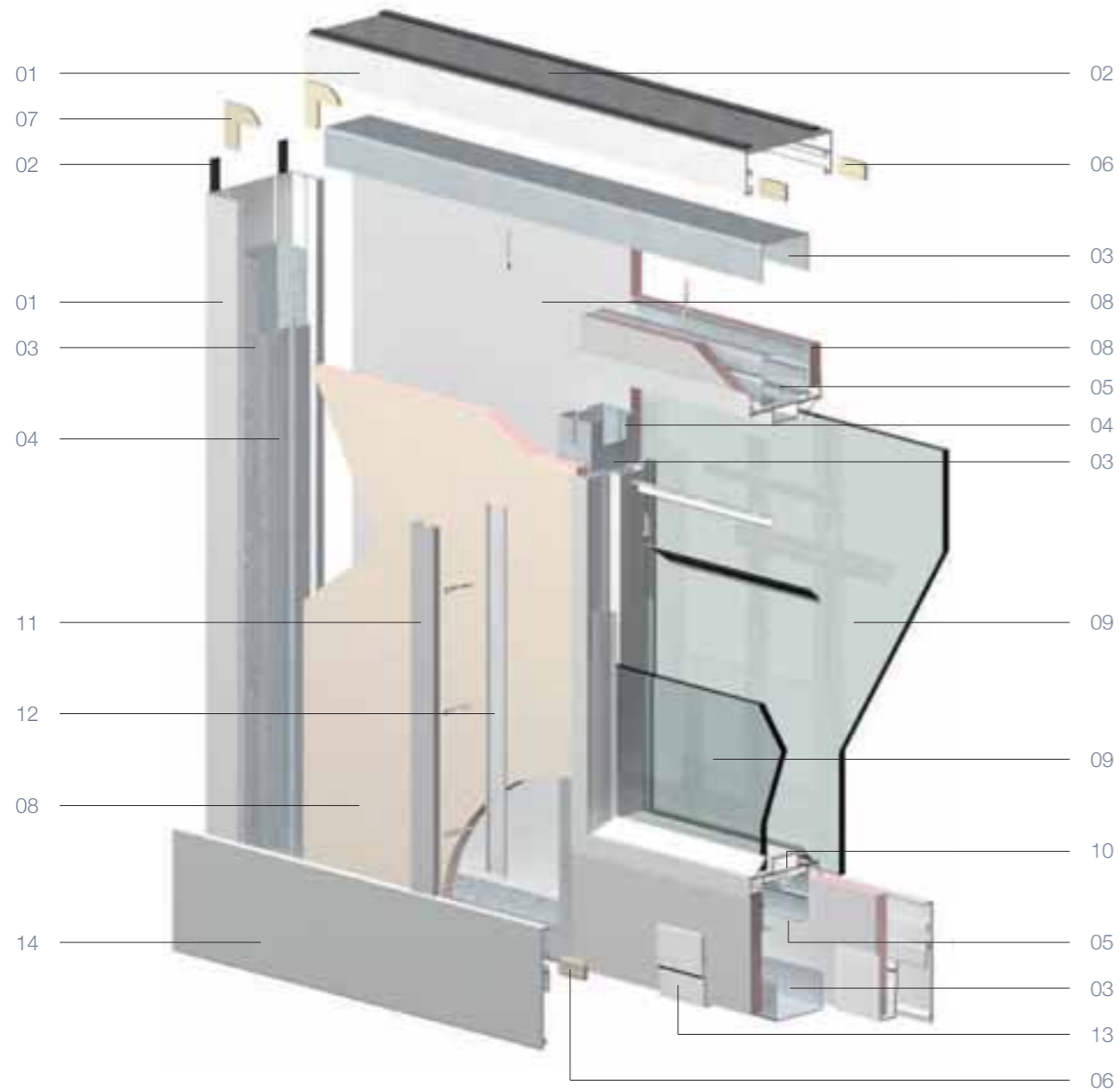

Komfire 75 - 75mm single skin partitioning system

- | | |
|----------------------------|-------------------------------|
| 01 Head / abutment channel | 09 6mm/6.4mm safety glass |
| 02 Abutment seal | 10 Pre-assembled window frame |
| 03 Steel head / base track | 11 Cover trim |
| 04 Steel vertical stud | 12 Steel batten |
| 05 Steel stud transom | 13 Skirting clip |
| 06 Straight jointing cleat | 14 100mm skirting |
| 07 90° jointing cleat | |
| 08 12.5mm plasterboard | |

Note: For clarity the cavity infill has not been shown

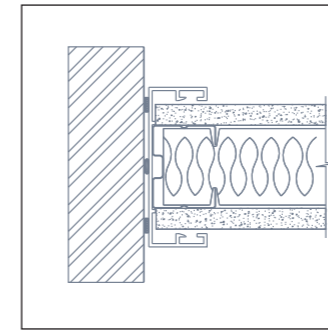

Solid abutment

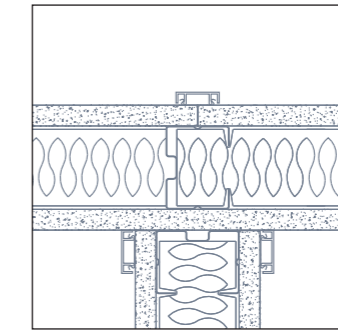

3 way solid junction

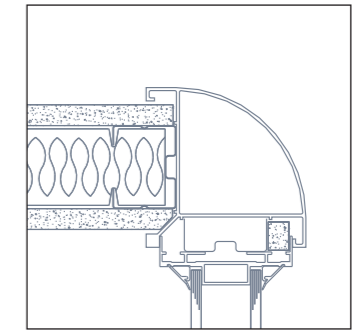

90° solid to glazed junction

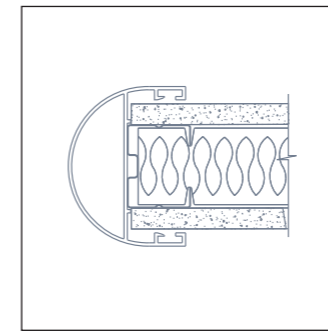

Solid fair end

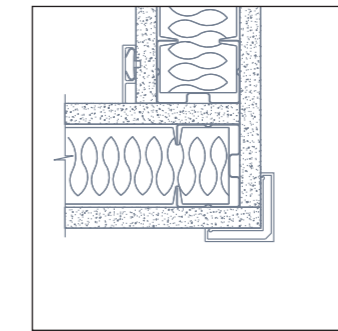

90° solid to solid junction

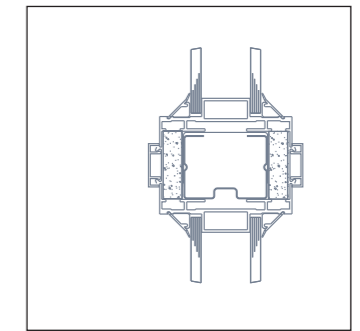

Glazed to glazed junction

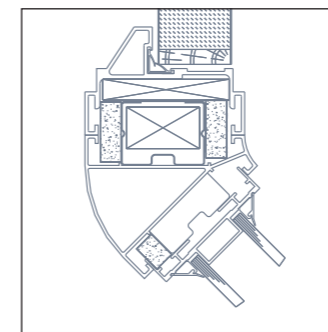

135° glazed to doorset junction

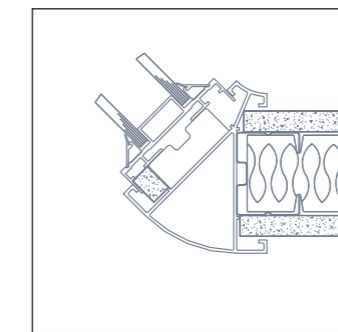

135° solid to glazed junction

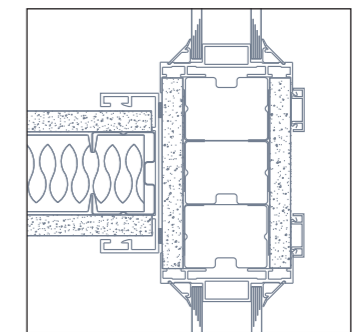

3 way glazed to solid to glazed junction

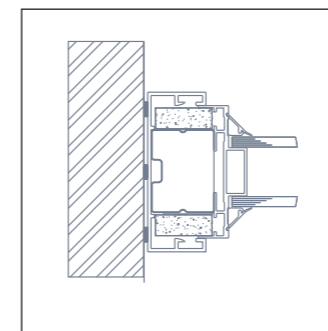

Glazed abutment

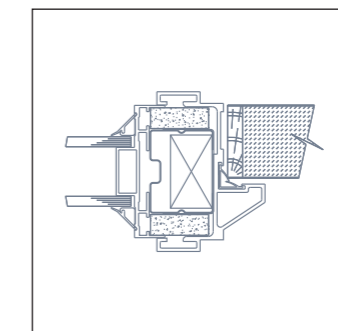

Glazed to doorset junction

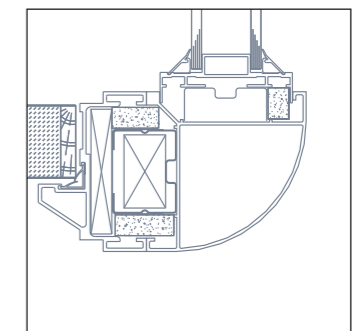

90° glazed to doorset junction

Full height solid and glazed Komfire 100 incorporating integral blinds, full height doorframes with standard height veneered door and rebated veneered overpanel

Komfire 100



Komfort partitioning product comparison chart can be found on the inside back cover of this brochure

resolute

Full height solid and glazed Komfire 100 incorporating integral blinds and veneered doors with rectangular vision panel and stainless steel kick plates

Komfire 100



Full height solid and glazed Komfire 100 incorporating integral blinds to the glazed sections

Komfire 100

Komfire 100 is a 100mm double skinned square edge trim system in a steel stud and plasterboard construction with pre-assembled window frames

Technical spec at a glance

 **DIMENSIONS:**
Up to 4800mm high (solid double skin)

 **FIRE RATINGS:**
Up to 60/60

 **ACOUSTICS:**
Solid - up to 52dB (Rw)
Double Glazed - up to 41dB (Rw)

 **STRUCTURE:**
Up to severe duty

 **WEIGHT Per m² (kg):**
Solid up to 46.08
Glazed up to 39.04

 **BLINDS:**
Yes - integral

 **MANIFESTATION:**
Yes

Detailed Komfire 100 drawings can be found on pages 42-43. In addition a partitioning product comparison chart can be found on the inside back cover of this brochure.

For further technical specifications and technical drawing downloads go to - www.komfort.com

Full height curved, solid Komfire 100



Komfire 100 is renowned for its impressive set of performance credentials and application possibilities. One partition with countless possibilities.

In spite of its incredible performance qualities, Komfire 100+, a double skinned variation can create an ambience that is inviting and appealing. It is the perfect choice for buildings where stringent fire regulations apply.

Komfire 100



Full height curved solid Komfire 100



Full height solid and glazed Komfire 100 incorporating veneered doors



Curved Komfire 100

Komfire 100

100mm double skin partitioning system

- 01 Head / abutment channel
- 02 Abutment seal
- 03 Steel head / base track
- 04 Steel vertical stud
- 05 Steel stud transom
- 06 Straight jointing cleat
- 07 90° jointing cleat
- 08 12.5mm plasterboard
- 09 6mm / 6.4mm safety glass or fire glass
- 10 Pre-assembled window frame
- 11 Cover trim
- 12 Steel batten
- 13 Skirting clip
- 14 100mm skirting

Note: For clarity the cavity infill has not been shown

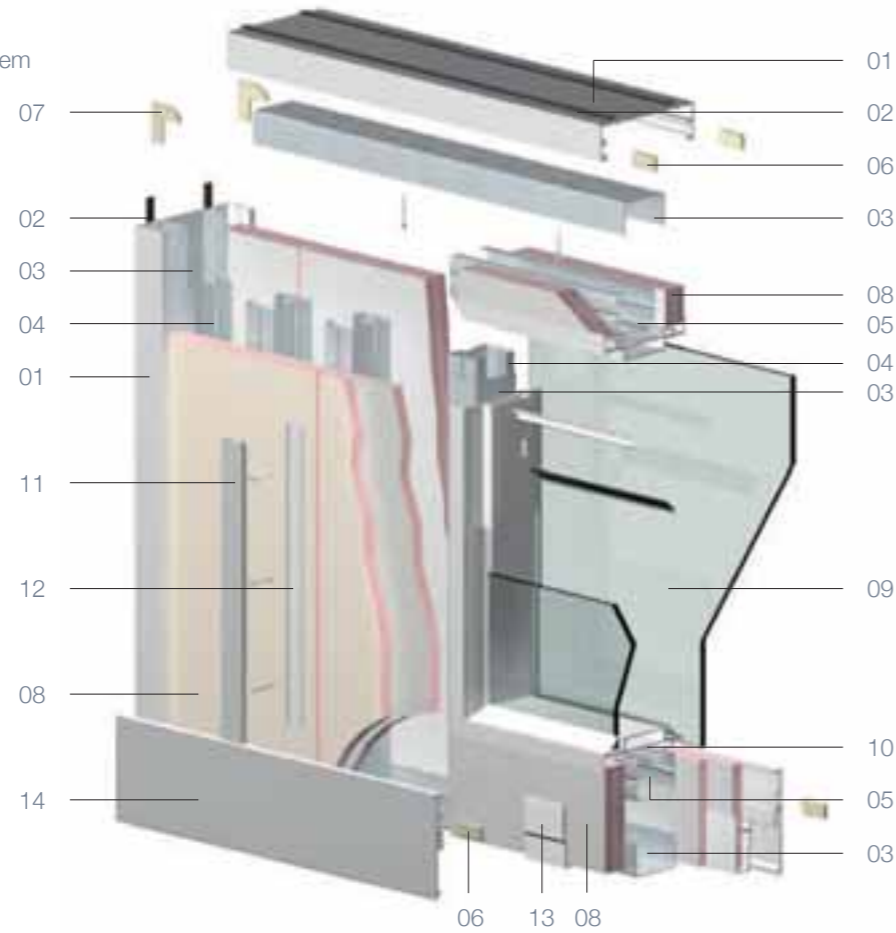

Komfire 100+

100mm double skin partitioning system & 60 minute glazed

- 01 Steel vertical stud
- 02 Steel head / base track
- 03 Steel stud transom
- 04 Aluminium window liner
- 05 Steel window liner
- 06 Pre-cut plasterboard strips
- 07 Foam seal
- 08 Steel glazing bead
- 09 Aluminium glazing trim
- 10 Glass up to 60 / 60 minute fire performance
- 11 Steel batten
- 12 Cover trim
- 13 12.5mm plasterboard
- 14 Skirting clip
- 15 100mm skirting
- 16 Straight jointing cleat
- 17 Timber door frame
- 18 FD60 door
- 19 Intumescent fire seal
- 20 Flaxcore strip ground

For Komfire 100+ junction drawings please contact our technical department

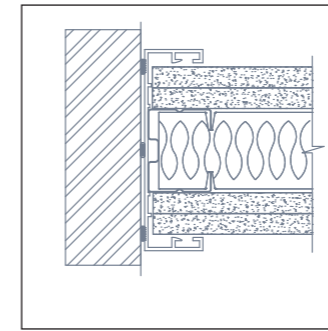
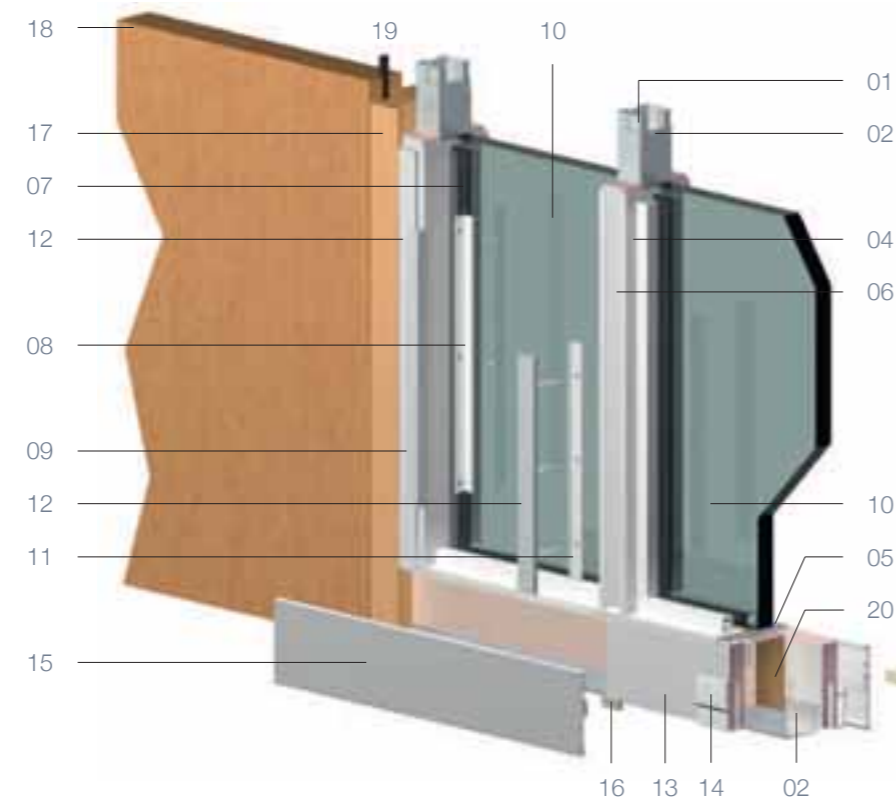

Solid abutment

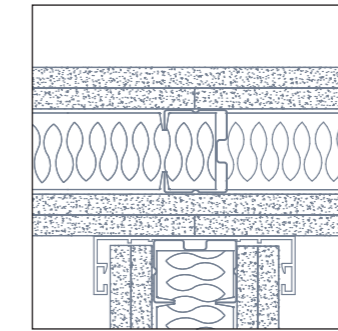

3 way solid junction

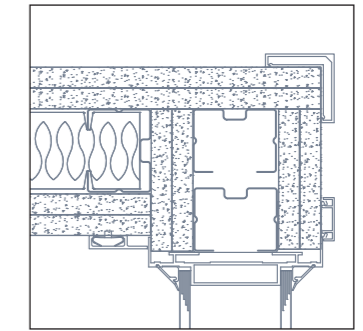

90° solid to glazed junction

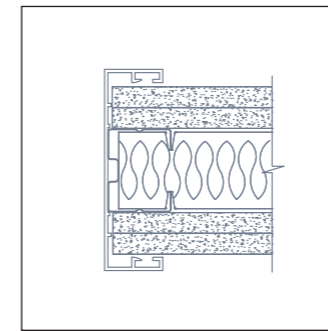

Solid fair end

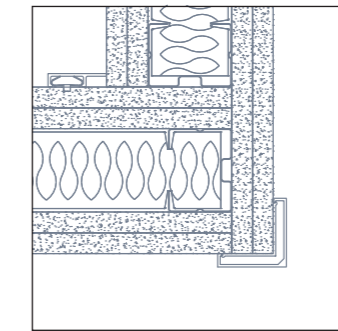

90° solid to solid junction

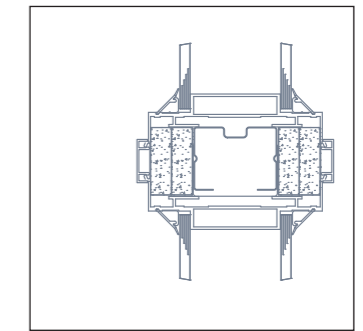

Glazed to glazed junction

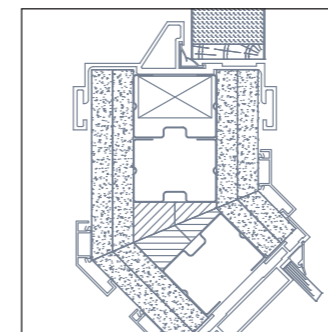

135° glazed to doorset junction

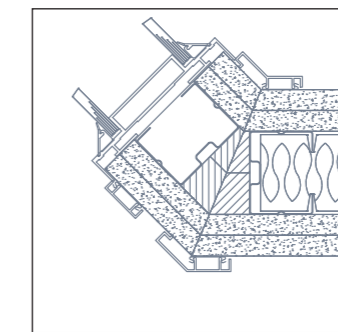

135° solid to glazed junction

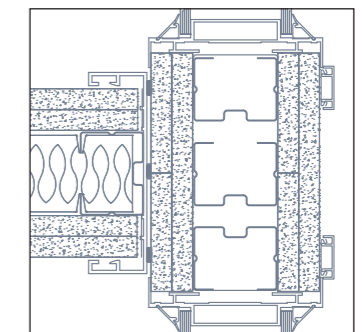

3 way glazed to solid to glazed junction

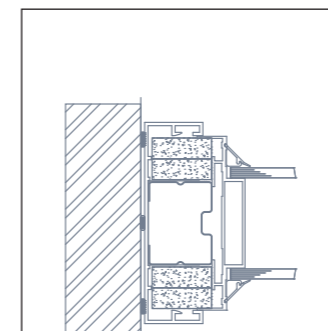

Glazed abutment

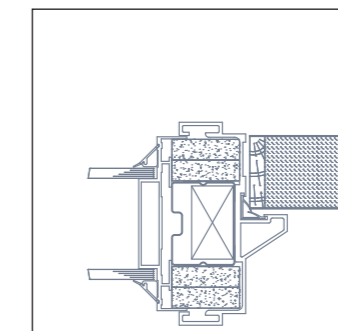

Glazed to doorset junction

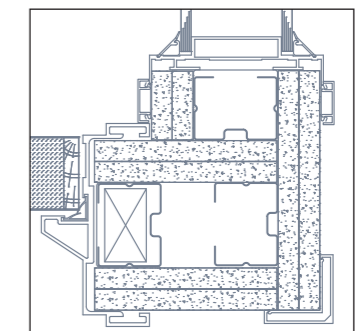

90° glazed to doorset junction

These drawings are for guidance only. For comprehensive information please contact our technical department



Komfort partitioning product comparison chart can be found on the inside back cover of this brochure

Full height single offset glazed
Klassik partitioning with applied
banded manifestation

Klassik

Komfort partitioning product comparison chart can be
found on the inside back cover of this brochure



sophisticated

Full height banded Klasic
with silicon jointed glazing

Klasic



Faceted full height
glazed and solid
Klassik with bespoke
wave manifestation

Klassik

Klassik is a radius edge veneered trim system in a steel stud and plasterboard construction with glazing options

Technical spec at a glance

 **DIMENSIONS:**
Up to 3000mm high

 **FIRE RATINGS:**
Up to 30/30

 **ACOUSTICS:**
Solid - up to 46dB (Rw)
Double Glazed - up to 41dB (Rw)

 **STRUCTURE:**
Up to medium duty

 **WEIGHT Per m² (kg):**
Solid up to 36.5
Glazed up to 45.5

 **BLINDS:**
Yes - integral

 **MANIFESTATION:**
Yes

Detailed Klassik drawings can be found on pages 52-53. In addition a partitioning product comparison chart can be found on the inside back cover of this brochure.

For further technical specifications and technical drawing downloads go to - www.komfort.com

Full height double glazed Klassic partitioning incorporating integral blinds



Exclusivity comes as standard with Klassic partitioning. The warmth and beauty of the veneers impart a timeless statement through both contemporary and classic design.

Klassic



Full height single glazed Klassic partitioning incorporating Part M compliant dot manifestation



Solid and glazed faceted Klassic



Full height single glazed Klassic partitioning incorporating banded manifestation and veneered doors

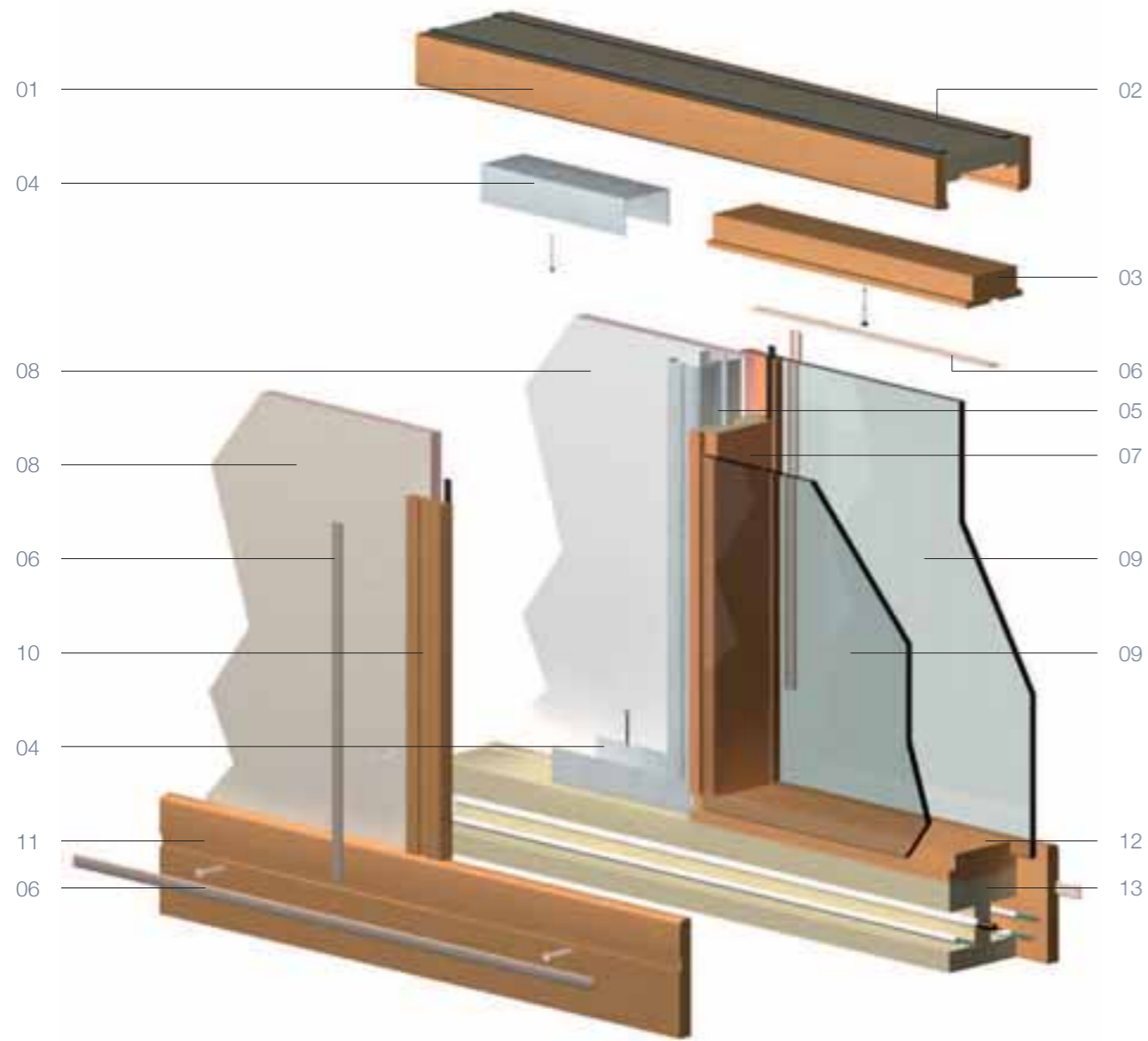

Klassik - 75mm veneered partitioning system

- | | |
|------------------------------|---|
| 01 Head channel | 08 12.5mm plasterboard |
| 02 Abutment seal | 09 6mm / 6.4mm safety glass or fire glass |
| 03 Horizontal glazing head | 10 Cover trim |
| 04 Steel head / base channel | 11 100mm skirting |
| 05 Steel vertical stud | 12 Glazing base |
| 06 PVCu infill | 13 Wireway base channel |
| 07 Glazing half post | |

Note: For clarity the cavity infill has not been shown

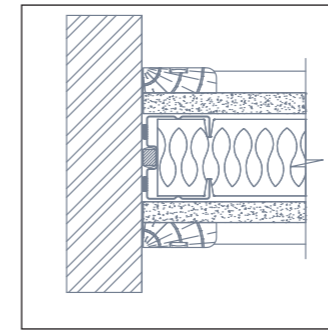

Solid abutment

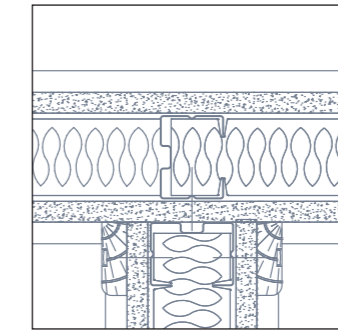

3 way solid junction

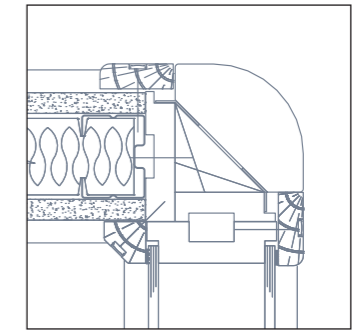

90° solid to glazed junction

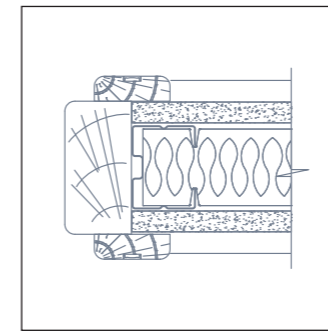

Solid fair end

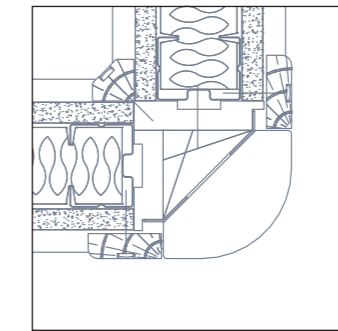

90° solid to solid junction

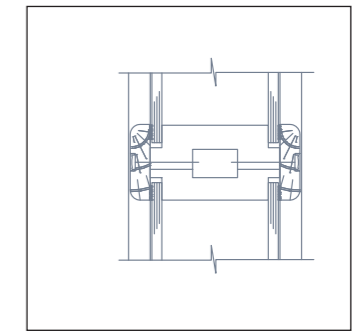

Glazed to glazed junction

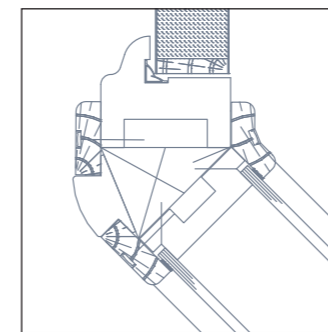

135° glazed to doorset junction

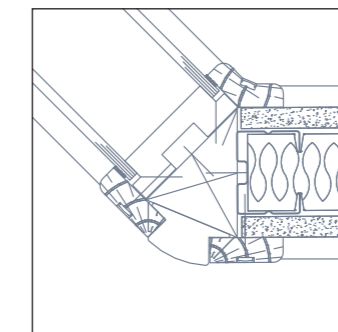

135° solid to glazed junction

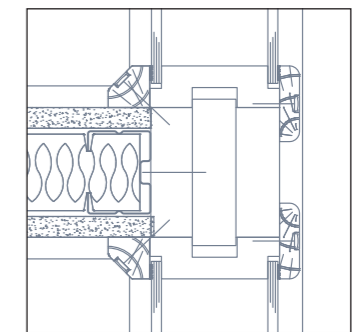

3 way glazed to solid to glazed junction

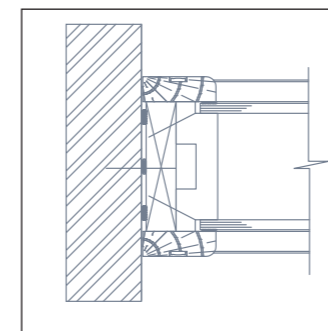

Glazed abutment

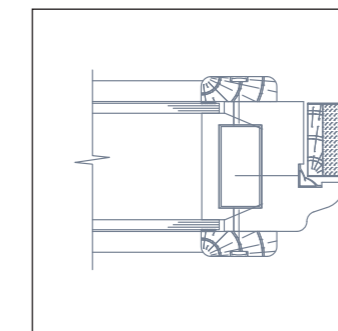

Glazed to doorset junction

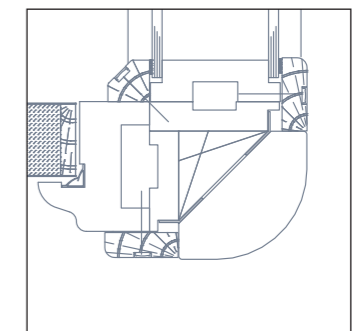

90° glazed to doorset junction



Banded landscape glazed Ls90 partitioning

Ls90



Komfort partitioning product comparison chart can be found on the inside back cover of this brochure



harmonious

Full height glazed Ls90 with clerestorey glazing and full height double glazed doors

Ls90





Full height glazed Ls90 with
banded applied film graphics

Ls90









Full height veneered Ls90
integrating with single
glazed Polar

Ls90

Ls90 is a recessed head and base bi-block system with a range of interchangeable panel types and finishes. It has been designed for future change with deflection head and base tracks creating a fully relocatable system

Technical spec at a glance

-  **DIMENSIONS:**
Up to 4000mm high
-  **FIRE RATINGS:**
Solid Panel - up to 60 minutes
Triple Glazed - up to 30 minutes
-  **ACOUSTICS:**
Steel Panel - up to 50dB (Rw)
Double Glazed - up to 45dB (Rw)
-  **STRUCTURE:**
Up to severe duty
-  **WEIGHT Per m² (kg):**
Steel faced plasterboard up to 31.51
Veneered up to 34.27
Glazed up to 55.43 (triple glazed)
-  **BLINDS:**
Yes - integral
-  **MANIFESTATION:**
Yes

Detailed Ls90 drawings can be found on pages 66-67. In addition a partitioning product comparison chart can be found on the inside back cover of this brochure.

For further technical specifications and technical drawing downloads go to - www.komfort.com



Creativity experiences a new freedom with Ls90. Its diverse panel options, striking materials and unlimited application possibilities ensure that designers' visions become reality.

Ls90



Full height glazed and solid Ls90 with integral blinds



Full height banded veneered Ls90



Full height glazed Ls90 with veneered doors and rebated overpanels

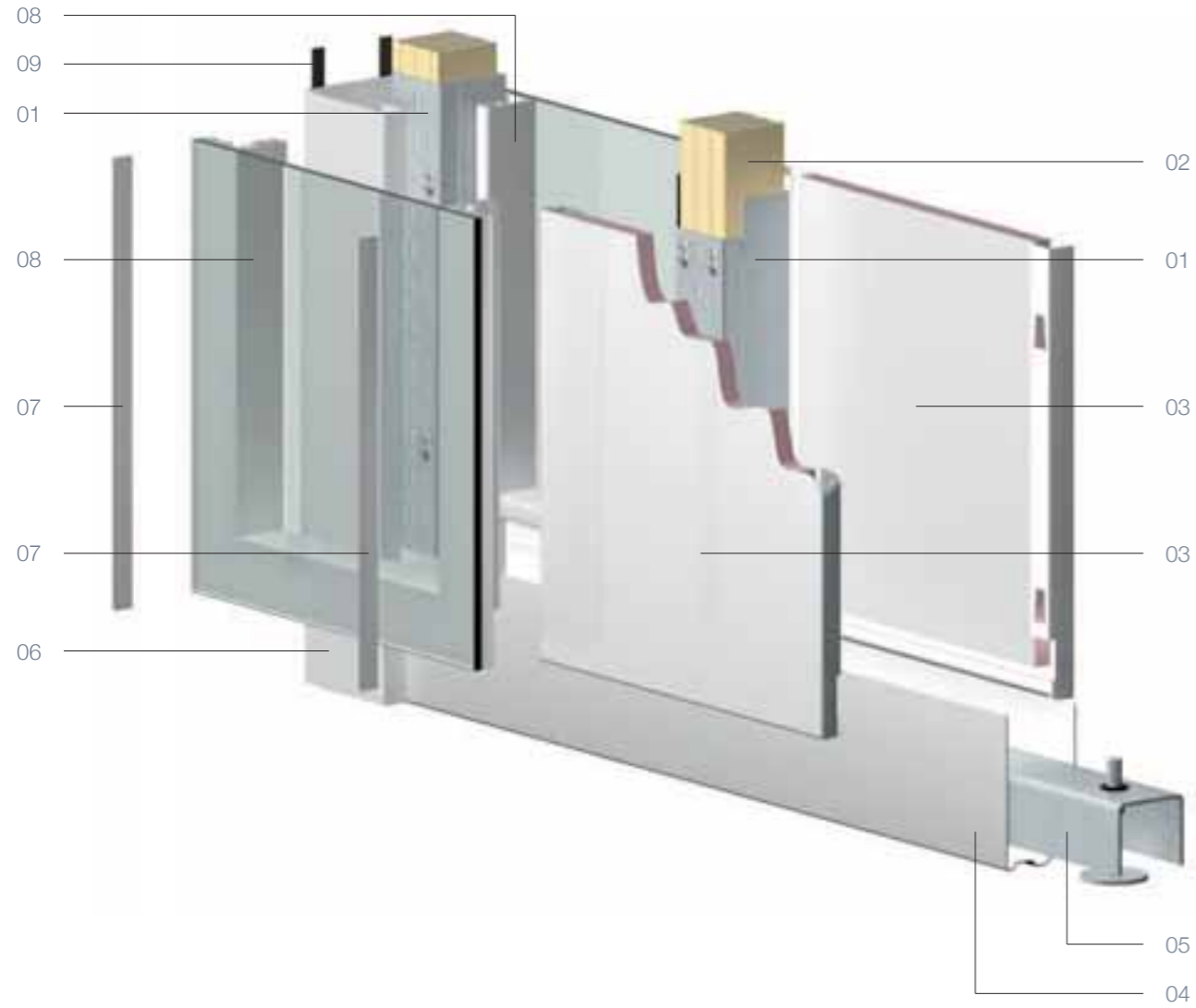

Ls90 - 90mm partitioning system

- | | |
|-----------------------------------|--------------------------------------|
| 01 Steel vertical stud | 06 Wall abutment channel |
| 02 Stud insulation | 07 PVCu joint infill |
| 03 Plasterboard steel faced panel | 08 Pre-assembled glazed window frame |
| 04 Steel base channel | 09 Abutment foam |
| 05 Steel levelling platform | |

Note: For clarity the cavity infill has not been shown

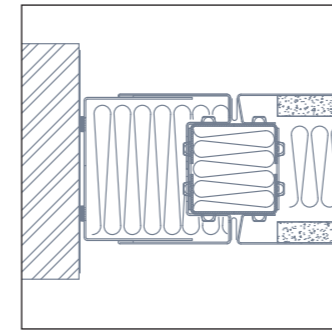

Solid abutment

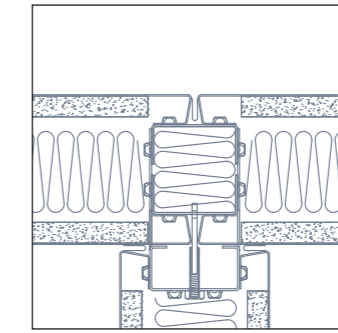

3 way solid junction

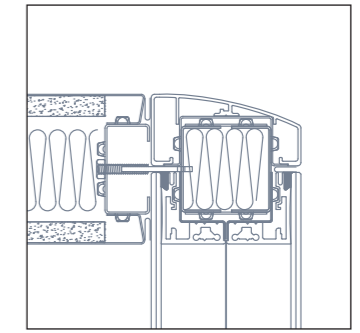

90° solid to glazed junction

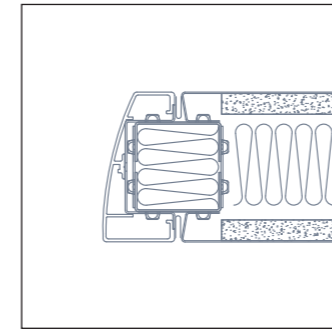

Solid fair end

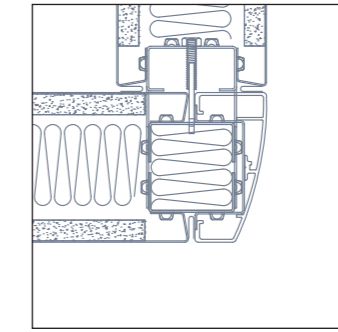

90° solid to solid junction

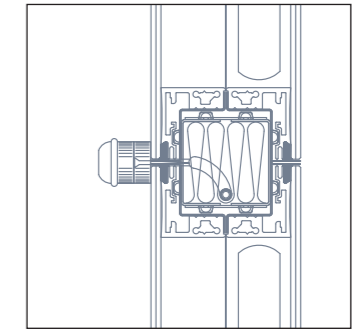

Glazed to glazed junction

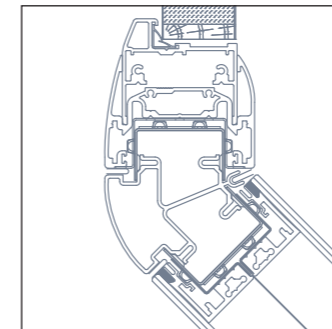

135° glazed to doorset junction

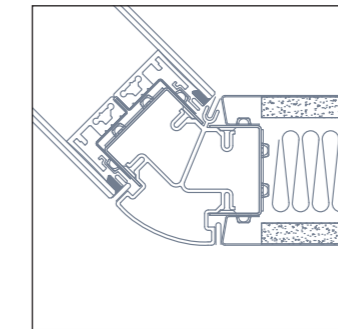

135° solid to glazed junction

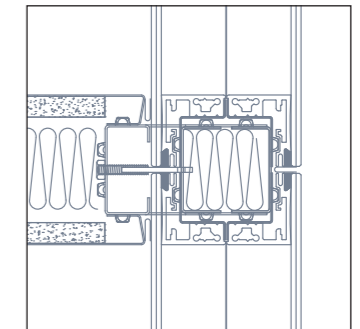

3 way glazed to solid to glazed junction

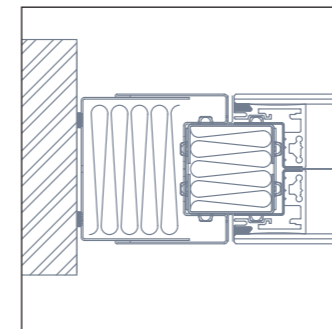

Glazed abutment

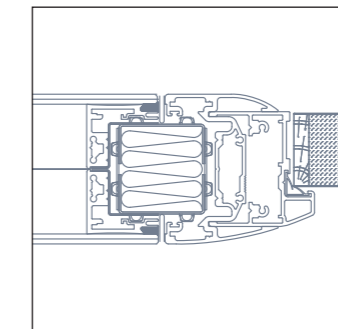

Glazed to doorset junction

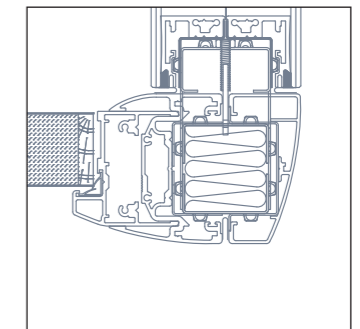

90° glazed to doorset junction



Full height glazed Ls90 with Workwall
storage and desking units



Ls90 featuring Workwall

intimate

Full height glazed Ls90 with veneered Workwall panel



Incorporating Workwall into double glazed Ls90 introduces a vertical, space saving aspect to the system. Designed to incorporate flat screen and telephone technology, these workstations are perfect for providing hot desking requirements.

Ls90 featuring Workwall



Ls90 with Workwall laminate panel



Glazed Ls90 with Workwall storage units



Workwall storage and desking units



KM³



dynamic

MFC KM³ storagewall integrating
with single glazed Polar partitioning

KM³









Ingenious and versatile, KM³ not only provides impressive storage capabilities but it can also double as a partition wall. Its flexible configuration accommodates many uses from intensive filing to the creation of audiovisual hubs. It is, without question, the ultimate space saving wall.

KM³



White laminate room divider
KM³ storage wall



MFC KM³ storage wall



Faceted KM³ in high gloss
white finish

KM³ storagewall filing specification guide

These pages are a quick guide to the filing permutations that can be installed within the KM³ storagewall system. To use this quick reference guide select the height and configuration of the unit required, then place a ruler along and above the appropriate dotted line and read below the ruler to determine the number of units and filing permutations the storage will achieve.

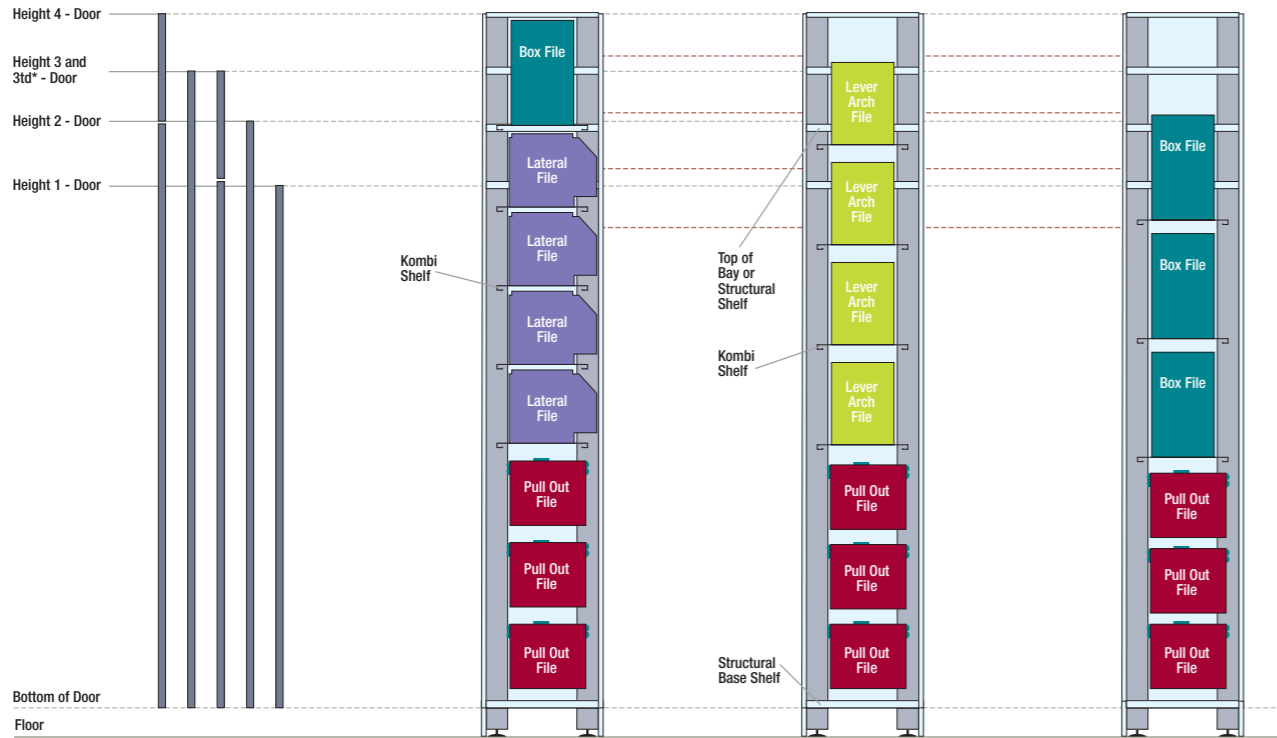

(* top door)

KM³ storagewall configurations



- | | | | | |
|---|---|--|--|--|
| 1 Wall cladding | 7 Flip chart | 14 Storage bay with mid unit | 19 Classic full height glazed partition with blinds | 25 KM ³ room divider with external shelving |
| 2 Full height doors with steel Kombi dividing shelves | 8 OHP and TV storage | 15 Veneered door with overpanel and vision panel | 20 Storage bays with flush wall backs | 26 Extended storage unit |
| 3 Column cladding | 9 Pull down projector screen | 16 Fire/sound performance partition | 21 Pull out filing drawer with glass doors | 27 Sliding doors |
| 4 Built-in KM ³ storage with bi-fold doors | 10 Whiteboard | 17 Full height tambour fronted bay | 22 Display unit with glass doors | 28 Polar single or double glazed partitioning with manifestation |
| 5 Glass door | 11 Storage bay with lateral filing | 18 Full height veneered door | 23 KM ³ room divider with doors above and drawers below | |
| 6 Fully glazed partition (single offset or double glazed) | 12 Veneered or laminated pass door | | 24 Wardrobe unit | |
| | 13 KM ³ room divider storage | | | |

Komfort partitioning product comparison chart can be found on the inside back cover of this brochure

American Black Walnut
veneered doors with
rectangular vision panels

Doors

Virtually unlimited decorative styles and moods can be captured with Komfort's veneered doors. The infinite variety of grain and figure pattern, colour and texture can create the most beautiful and distinguished environments. Glass and laminate doors complete the portfolio.

tactile

Crown cut White Oak veneered door



Crown cut English Yew veneered door



Doors

Crown cut Ash veneered door



Rotary cut Kevasingo veneered door



Doors

Crown cut Cherry veneered door



Crown cut Steamed Beech veneered door



Doors

Rotary cut Birch veneered door



Birds Eye Maple veneered door



Doors

Standard Door Frames Aluminium Extrusion

Frames are powder coated to specified standard RAL and BS colours

*Standard Timbers:
 Utile
 Ash
 Steam Beech
 Oak
 Cherry
 Joinery quality softwood

#Standard Veneer Profiles:
 White Oak
 Ash
 Maple
 Steam Beech
 Cherry

Bespoke profiles and other timber species available on request.

Standard Door Frames Timber and Veneered

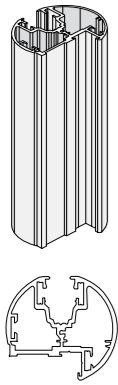

Code: SJ6
 Polar Single Glazed
 Single acting door frame
 (Non-fire performance)

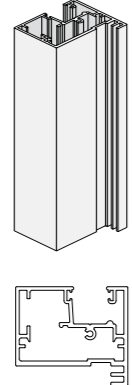

Code: SJ35
 Polar Single Glazed - Single action
 doorframe (Flush door option)
 (30 minute fire performance)

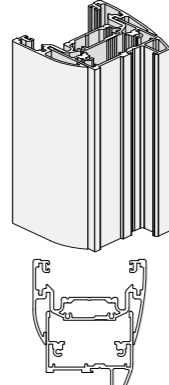

Code: NEDF
 Ls90
 Standard single acting doorframe
 (30 minute fire performance)

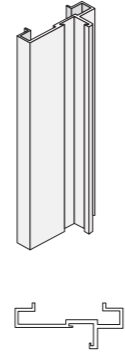

Code: 628
 600 Series
 Single acting door frame
 (Non-fire performance)

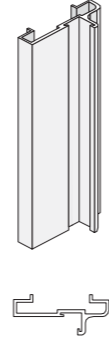

Code: 629
 Kameo 50
 Single acting door frame
 (Non-fire performance)

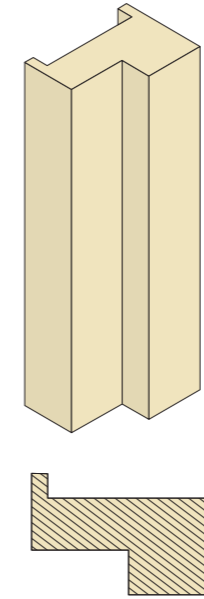

Code: A79*
 Single acting door frame for 75mm system
 FD30

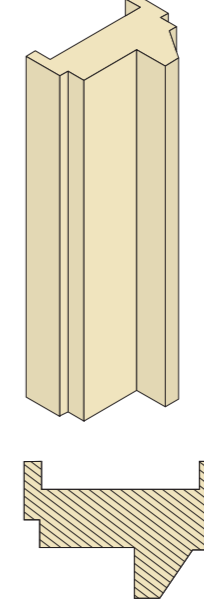

Code: B106*
 Single acting door frame for 75mm Komfire
 partitioning system
 FD30

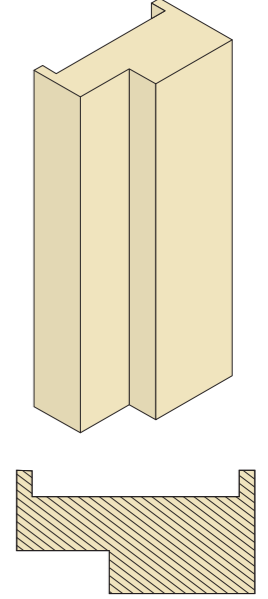

Code: A104*
 Single acting door frame for 100mm system
 FD60

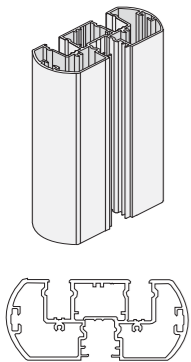

Code: DGP3
 Polar Double Glazed
 Single acting door frame
 (Non-fire performance)

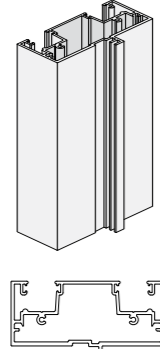

Code: DGP25
 Polar Double Glazed
 Single action doorframe
 (30 minute fire performance)

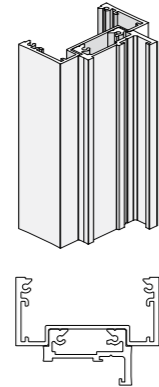

Code: NDSV
 Ls90
 Slimline single acting doorframe
 (30 minute fire performance)

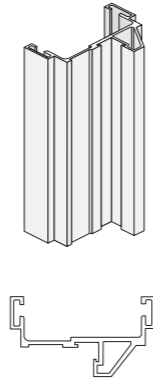

Code: 816
 Komfire 75
 Single acting door frame
 (30 minute fire performance)

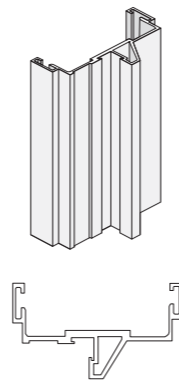

Code: 826
 Komfire 100
 Single acting door frame
 (30 minute fire performance)

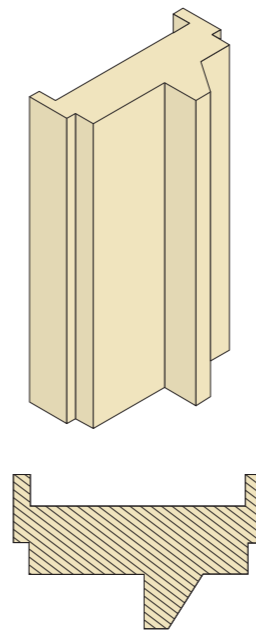

Code: B206*
 Single acting door frame for 100mm
 Komfire partitioning system
 FD60

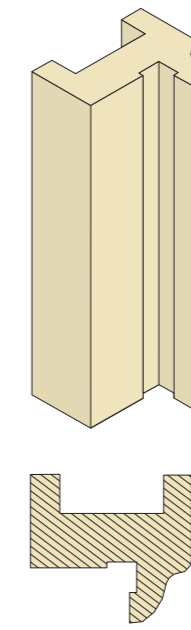

Code: TP538#
 Single acting veneered door frame for
 75mm Klassik partitioning system
 FD60

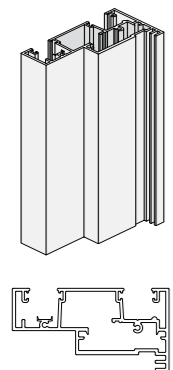

Code: DGP26
 Polar Double Glazed - Single action
 doorframe (Flush door type)
 (30 minute fire performance)

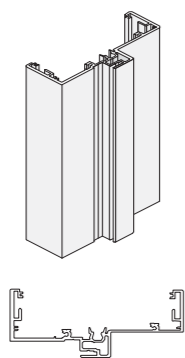

Code: PSQ4
 Polar 100
 Single acting door frame
 (Non-fire performance)

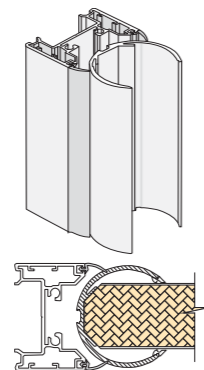

Code: CXA200 / CXA203
 Ls90 - Double acting swing door
 frame using 54mm thick door
 (30 minute fire performance)

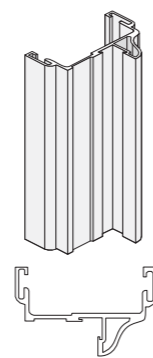

Code: M58
 Kameo 75 and Mirage
 Single acting door frame
 (30 minute fire performance)

Vision Panel Bead Styles

Suitable for 44mm thick doors, either non-fire or fire rated, as shown (size and position limitations apply). Vision panel specifications are also available for 60 minutes fire performance within a 54mm thick door.

Vision Panel Size including multi-panel design

Door Action	FD30 Maximum Area m ²	FD60 Maximum Area m ²
Latched single doors	0.80	0.60
Unlatched single doors		
Latched double doors	0.50	0.55
Unlatched double doors	0.04	

Approved Fire Glass

Thickness	Brand Name	Finish	FD30	FD60
6mm	Komfort	Clear	✓	
	Pyran		✓	✓
	Pyrocet		✓	
7mm	Pyrobelite		✓	

Standard Vision Panel Range

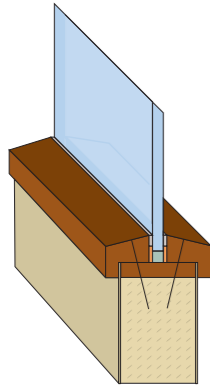

Style H10
Timber bead, square, rectangular, circular or shaped glazing detail

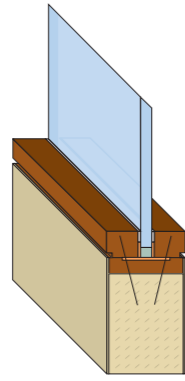

Style Q
Timber quirk bead, square or rectangular glazing detail

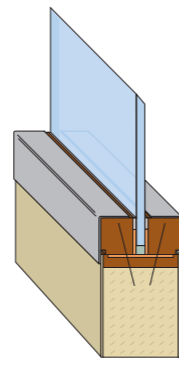

Style QC
Timber bead with metal cover trim, square, rectangular or circular glazing detail

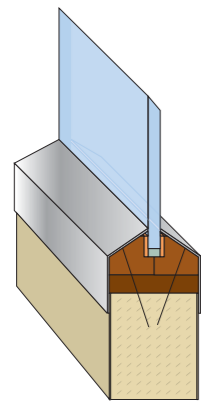

Style S44
Timber bead with stainless steel cover trim, rectangular or circular glazing detail

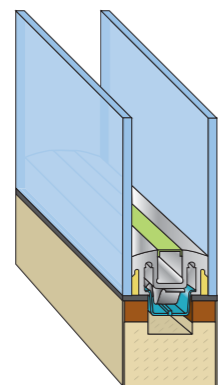

Style FD
Non-fire performance aluminium frame flush double glazing detail (Patent Applied)

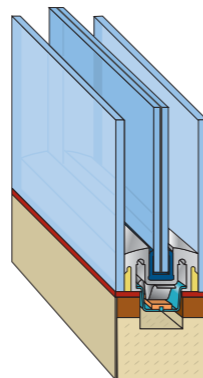

Style FT
Aluminium frame flush triple glazing detail (Patent Applied)

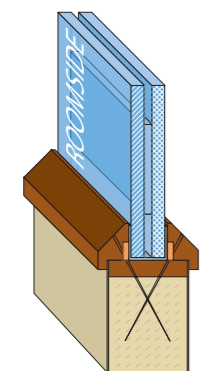

Style V44
Manually operated privacy panel

- Approved fire safety glass
- 4mm thick toughened glass
- 7mm Pyrobelite fire safety glass
- 6mm Pyran S approved safety glass
- 6mm thick toughened glass
- Komfort's FD30 veneered, laminate or PVCu faced solid core door
- Hardwood bead
- Intumescent
- Intumescent silicon
- Silicon seal
- Plastic
- Non-combustable packer
- Foam
- Aluminium glazing extrusion
- Hot metal bonding
- Glazing gasket
- Satin stainless steel cover trim
- Sprung channel
- Steel powder coated cover trim

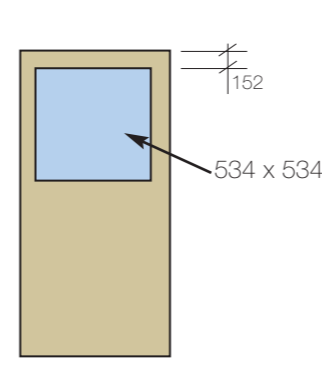

Code: 460

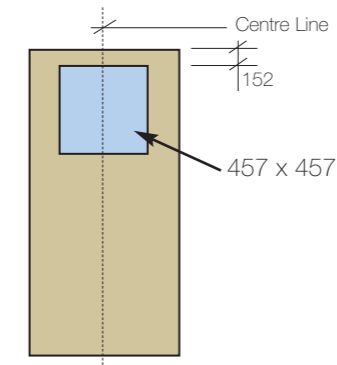

Code: 459

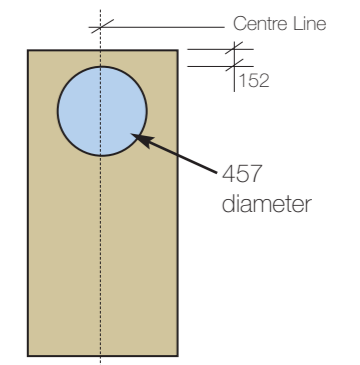

Code: 462

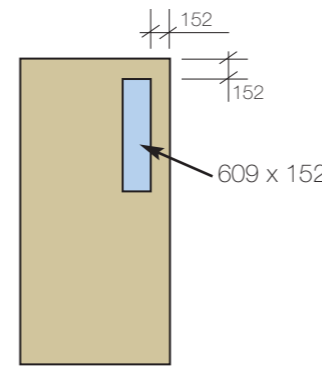

Code: 463

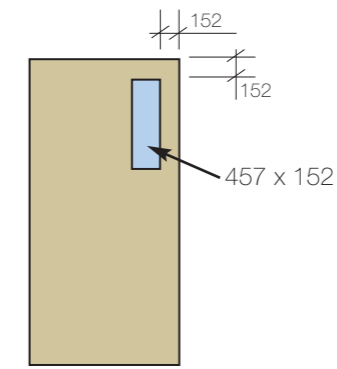

Code: 458

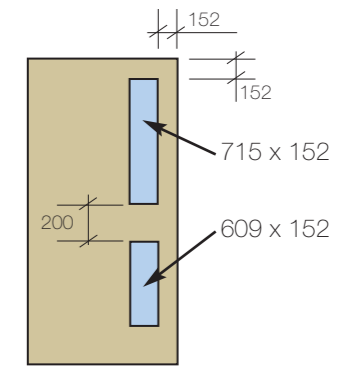

Code: 461.S*

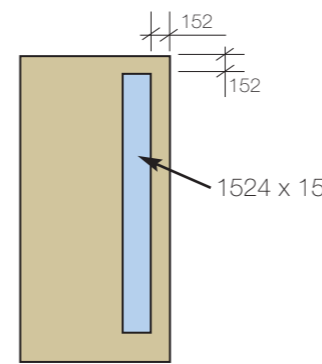

Code: 464*

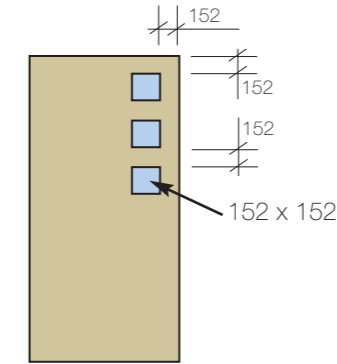

Code: 508.3

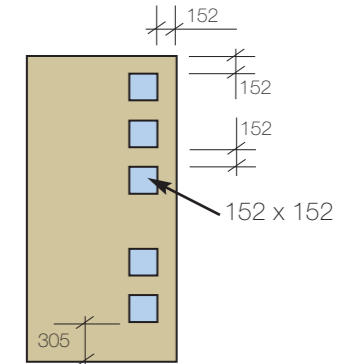

Code: 508.5

Other shapes and sizes of vision panels are available to order either non-fire or fire rated (size and position limitations apply).
*Part M compliant

Veneer Production

The doors that are displayed prior to this page have been manufactured with care and precision at each stage of the production process. When specifying the finish, it is important to decide the preferred cutting and matching method at an early stage, as this will dictate the style and look of the completed door.

It starts with the slicing or peeling of a log to produce a thin layer of wood veneer. Each layer is usually cut to a uniform thickness of about 0.6mm. There are five prominent cutting methods which, when employed, create diverse visual effects. Even logs from the same species may produce veneers with a completely different appearance.

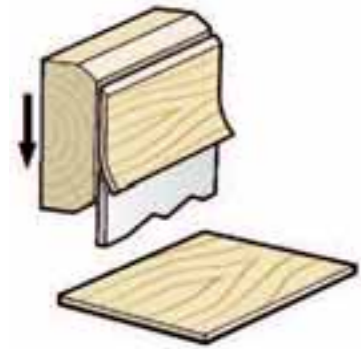

Flat Sliced

With flat slicing, the half log is mounted with the heart side placed flat against the table of the slicer. Slicing is then carried out parallel to a line through the centre of the log, exposing the crown or heart wood. The often attractive and highly individual crown features are emphasised.

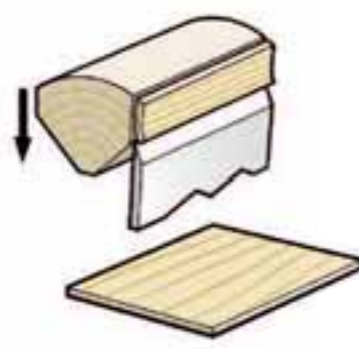

Quarter Cut

The quarter log is mounted on the table so that the growth rings of the log strike the knife at right angles. The variations in colour brought about by summer and winter growth produce a straight grain effect.



Rift Cut

This method is predominately employed to slice the various species of oak, which have medullary rays radiating from the centre. The rift or straight grain effect is obtained by cutting at an angle of about 15% off the quartered position to avoid the flake figure of the medullary rays. Rift cut veneer usually produces wider leaves than quarter sliced.



Half-Round Cut

A variation of rotary cutting in which segments of the log are mounted off-centre in the lathe. Curved slices are taken slightly across the annular growth rings, producing a veneer with some of the characteristics of both crown cut and rotary veneers.



Rotary Cut

Rotary cut veneer is created from a continuous peeling of the log to produce a multi-patterned grain marking. Veneers formed using this method are exceptionally wide. Rotary cutting is generally employed for almost all burl veneers, birds eye maple or birch.

Veneer Matching

Veneer matching is an art in itself. Its purpose is to arrange the slices of veneer, using the natural repeat of the grain, to form a multiplicity of decorative patterns and effects. The veneer leaves, once sliced, are stacked in consecutive order for ease of selection and matching.

Each leaf is delicately different, yet closely related to the adjoining leaves, so that the various forms of matching can be applied. Experts in the field of matching will make the most of each species' characteristics to create the finest composition.



Book Matching

Taking successive leaves of veneer and reversing each alternate leaf so as to bring opposite edges together achieves a mirror effect. This method suits crown and quarter cut veneers equally well. When applying this technique to light coloured species, there is a tendency towards a shading effect which emphasizes each veneer leaf on the door. Where this is not suitable the veneers should be slip matched.



Random Matching

This is where leaves from the same species but not always from the same log are selected at random and are deliberately mixed and mismatched to produce a haphazard plank effect with no regular pattern. The veneer sheets vary in width and appearance characteristics.

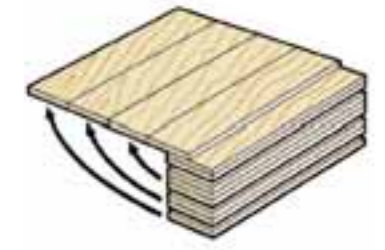

Mismatching

Leaves from one log are randomly mixed to give a plank effect whilst maintaining an overall consistency in grain and colour.



Slip Matching

Each veneer leaf is slipped across the next rather than being turned. This produces a repeat pattern which is best suited to straight grain veneers.



Quarter Matching

Normally applied to butts, burls and curls, this is where panels are made up from four pieces of veneer which are book matched both from side to side and then from top to bottom. This forms a feature which radiates from the centre.

Sequential Book Matching

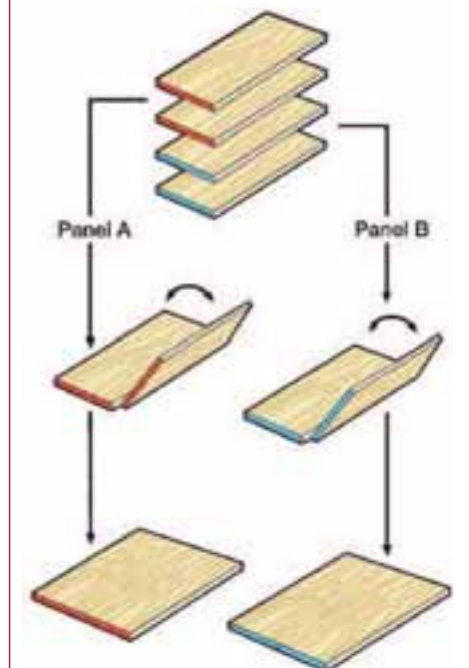

Integral blinds and knob controls
within Klasic partitioning

Blinds & Graphics

Offices are often designed to be an expression of a corporation, its values and its brands. What simpler way to achieve these objectives than through Komfort's extensive portfolio of decorative glass manifestation, digital graphics, commercial signage, new EC film technology and a range of blind systems. Colour too can provide sensation and spectacle – without doubt the ultimate finishing statement.

Kameo 75 featuring integral blinds with control knobs shown open and closed



Banded printed film graphics applied to Ls90



Blinds & Graphics

Part M compliant dot manifestation and vertical blinds applied to Klasic partitioning



Komfort's Polar Partitioning

Komfort's Polar partitions are stylish, dynamic and technologically sophisticated. They allow light to permeate through the space they divide to nurture inspiration and collaborative working.

For a copy of Komfort's Polar brochure contact your local sales office, or download it from komfort.com

Uniclass	EPIC
L384:P314:D32	C441:X342
C/SfB	
32	(22.3) Xo



Polar Partitioning

Love the space you're in.

Full height single glazed Polar incorporating pivot single glazed doors with patch fixings and glazed overpanel



Full height double glazed Polar incorporating single glazed doors within full height Halo doorframes



Komfort's
Polar Partitioning

Specialist expertise

To maintain our position as market leader in the design, manufacture and supply of partitioning systems, Komfort as part of SIG Interiors Manufacturing, offer specialist expertise in the following areas:

- When it comes to structural strength, fire and sound performance, Komfort operates an uncompromising programme of product testing to ensure peace of mind. Our partitioning and doors are independently tested at authorised laboratories in accordance with the relevant British Standard. The results and summaries of performance can be accessed on komfort.com
- Specialist technical expertise based on long term product research and development and an unrivalled understanding of the needs of the contractor and end user gained from supplying complex and large projects.
- Experienced in nationwide supply chain agreements, offering logistics expertise and scale with dedicated project management that monitors manufacturing deadlines and schedules from order, through to production and delivery.
- Investment in specialist distribution to offer the widest selection of products, stocked in depth and delivered in consolidated loads, reducing disruption and minimising environmental impact.
- Extensive on going investment in tooling and manufacturing facilities to deliver cost effective, high quality products and continual improvements to service.
- Full accreditation to BS EN ISO 9001, 14001 and OHSAS 18001.

Key services

We offer our clients a comprehensive range of services prior to and throughout the duration of a project. These include:

- RIBA approved CPD seminars.
- NBS specifications.
- Full design and project visualisation facilities.
- Estimating service.
- Experienced technical support and guidance.
- Web accessible technical documentation including junction drawings in CAD and PDF format, performance certification and installation statements.
- Sales support services including hand and component samples.
- Site surveys for glass and blinds.
- Product installation training.
- Dedicated support line for specifiers.
- Marketing material including brochures and product photography.
- Nationwide show suites.

Komfort would like to thank the following photographers and companies for granting us permission to use their photography in this brochure. Many of the projects featured are available to view and download as case studies on www.komfort.com

Andrew Perris – www.andrewperris.co.uk
Christian Smith
David Parker – www.daveparker.org
Donal Murphy – www.donalmurphyphoto.ie
James White – www.jameswhitephotography.co.uk
Mike Torrington – www.miketorrington.com
Paul Zanre – www.pzphotography.com
Steve Mayes – www.stevemayesphotography.co.uk

Altered Interiors (London) Ltd – www.alteredinteriors.co.uk
Ambient Interiors – www.ambient-interiors.co.uk
Amspec Limited – www.amspec.co.uk
Artemis Interior Services Ltd – www.artemisinteriors.com
Axis (Scotland) Limited – www.axis.gb.com
Aztec Interiors – www.aztec-interiors.co.uk
BAM – www.bam.co.uk
Bond Bryan Architects – www.bondbryan.com
Cairn Contracts – www.cairncontracts.com
CBS Business Furniture Ltd - www.cbsofficeinteriors.co.uk
CPL Interiors – www.cplinteriors.co.uk
D&G Office Interiors – www.dgoi.co.uk
Europa Workspace Services – www.europa-services.co.uk
FORM – www.forml.co.uk
GVA Grimley – www.gvagrimley.co.uk
Maris Interiors LLP – www.maris-interiors.co.uk
Office Principles – www.officeprinciples.com
One to One Business Interiors – www.onetoonebusinessinteriors.com
Parias Commercial Interiors Ltd – www.pariasinteriors.com
PW Shopfitters Ltd – www.pwshopfitters.co.uk
Service Group Interiors – www.servicegroupinteriors.com
S.J. Interiors (Essex) Limited - www.sjinteriors.co.uk
Souness & Boyne – www.sounessandboyne.co.uk
Spaceway South Ltd – www.spaceway.co.uk
Stortford Interiors (UK) Ltd – www.stortford-interiors.com
Swift Refurbishments – www.swiftrefurbishments.co.uk
Time Limit Interiors, Leeds
Trevor Blake Limited – www.trevorblake.co.uk
Walls to Workstations – www.w2w.ie

Brochure Design & Artwork - www.shoal.co.uk



Kompendium - system guide & performance options

	Panel Finish				Trim Finish			Glazing BS6262 & BS 6206 also 476: Part 22 when required			Door Finish			Fire Performance BS 476 : Part 22				Sound Performance dB (Rw) BS EN ISO 140-3			System Construction								
	Vinyl using contract width fabric or paper backed materials	MFC non glare finish with PVC high impact edging	Veneer crown cut to match doors and finished with UV lacquer	Steel Faced	Square Edge Profile	Radius Edge Profile	Kolourframe powder coated in any BS 4800 or RAL colour	Veneered	Single Centre	Single Offset	Double Glazed	Certificated Doorset Assembly	Veneer pre-finished with UV lacquer	Laminated or PVCu	MFC	Steel in any BS 4800 or RAL colour	Glass performance 12mm thick toughened	Solid	Glazed	Doorset	Fire Glass module maximum area	Solid with tested cavity infill	Single Glazed 6.4mm laminated	Double Glazed 2 x 6.4mm laminated	Solid Strength & Robustness BS 5234 duty level	Nominal Thickness	Nominal Width	Maximum Height (subject to post installed)	Safety Glass (non performance) module maximum area
600 Series	■				■	■			■	■	■	■	■					None	None	None	NA	30	33	37	Light	50mm	1.2m	6.0m ^f	3.24m ² ^f
Kameo 75	■	■	■			■			■	■	■	■	■				30min	30min	FD30	3.21m ²	43	35	40	Medium ^d	75mm	1.2m	4.3m	3.60m ²	
Komfire 75	■	■	■			■			■	■	■	■	■				30min	30min	FD30	3.21m ²	43	35	40	Medium ^d	75mm	1.2m	4.3m	3.60m ²	
Komfire 100	■	■	■			■			■	■	■	■	■				60min	30min	FD60 ^a	3.21m ²	52 ^b	35	40	Severe ^d	100mm	1.2m	4.8m	3.60m ²	
Komfire 100+	■	■	■			■			■	■	■	■	■				60min	60min	FD60 ^a	3.60m ²	52 ^b	35	NA	Severe ^d	100mm	1.2m	4.8m	NA	
Klassic	■	■	■			■			■	■	■	■	■				30min	30min	FD30	3.36m ²	43 to 45 ^c	35	40	Medium ^d	75mm	1.2m	3.0m	3.60m ²	
Ls90	■	Laminate	■	■	■	■			■	■	■	■	■				60min	30min	FD30	3.29m ²	45 to 50 ^c		42 to 45	Severe ^g	90mm	1.2m + up to 2.5m* ^h banding only	2.9 - 5m	3.29m ²	
KM ³	■	■	■			■			■	■	■	■	■				None	None	None	NA	52	NA	NA	NA	450mm ^e	1.2m max double bay	3.25m	NA	NA

600 Series 46mm Composite honeycomb core boards into aluminium frame
 Kameo 75 Single skin 12.5mm plasterboard either side of 50mm steel stud
 Komfire 75 Single skin 12.5mm plasterboard either side of 50mm steel stud
 Komfire 100 Double skin 12.5mm plasterboard either side of 50mm steel stud
 Komfire 100+ Double skin 12.5mm plasterboard either side of 50mm steel stud
 Klassic Single skin 12.5mm plasterboard either side of 50mm steel stud
 Ls90 90mm recessed head and base bi-block system
 KM³ Integrated Storage

* Back panels
 ** Glass combination

a - Timber frame
 b - SoundBloc
 c - Subject to cavity infill
 d - At 2.7m high
 e - Room divider
 f - Subject to post installed
 g - At 3.0m high

Love the space you're in.



Komfort Workspace plc Sales Offices - UK

Crawley

Whittle Way
Crawley
West Sussex
RH10 9RT
Tel: +44 (0)1293 592500
Fax: +44 (0)1293 553271
E-mail: general@komfort.com

Birmingham

Globe House
Parkrose Industrial Estate
1 Middlemore Road
Smethwick
Birmingham
B66 2DR
Tel: 0121 555 0300
Fax: 0121 555 0301
E-mail: midland-sales@komfort.com

Manchester

8 Brindley Road
City Park Business Village
Trafford Park
Manchester
M16 9HQ
Sales Tel: 0161 877 9517
Fax: 0161 873 8540
Showroom Tel: 0161 873 8539
E-mail: northern-sales@komfort.com

Scotland

14 Grange Road
Livingston
West Lothian
EH54 5DE
Tel: 0131 661 7010
Fax: 0131 661 5768
E-mail: scotland-sales@komfort.com

Leeds

Unit 2
Intermezzo Drive
Stourton Link
Leeds
West Yorkshire
LS10 1RU
Tel: 0113 395 6565
Fax: 0113 395 6566
E-mail: northern-sales@komfort.com

Sales Office - Republic of Ireland

First Floor
Block 43a
Park West Business Park
Nangor Road
Dublin 12
Tel: 01 620 5616
Fax: 01 620 4380
E-mail: dublin-sales@komfort.com

Show Suite Locations

Gatwick International
London - City
Birmingham
Leeds
Manchester
Dublin

Internet

www.komfort.com

komfort.com