

**SOUNDPROOFING SYSTEM
TO REDUCE NOISE TRANSMITTED
BY FOOTSTEPS**



Index

Living comfort	3
Thermal comfort.	4
Noise: what a nuisance!.	5
Soundproofing system	6
Soundproofing: the answer	7
Mapesilent®	8
Advantages	9
Typical application examples	11
Designing an insulation system.	12
Application.	14
Mapesilent® Panel	15
Mapesilent® Roll	18
Installing screeds	21
Finishing off skirting boards	22
Radiating heated floors	23
Technical drawings	24
Laboratory measurements	26
Dynamic stiffness (S') Mapesilent® Roll	
Laboratory measurements	27
Dynamic stiffness (S') Mapesilent® Panel	
Laboratory measurements	28
Reduction of transmitted impact noise on standard floor slab insulated with Mapesilent® Roll	
Laboratory measurements	29
Reduction of transmitted impact noise on standard floor slab insulated with Mapesilent® Panel	
On-site measurements	30
Anit Certificate - Naked slab	
On-site measurements	31
Anit Certificate - Finished flooring (slab + floating screed)	

Living comfort

Floors must guarantee sufficient acoustic insulation against airborne noise which travels from one building to another, and the transmission of noise caused by footsteps between one household and another. According to European standards, insulation against airborne noise is determined by the parameter R'_{w} , (STC - Sound Transmission Class for Canada and USA) which corresponds to the degree of apparent noise insulation of elements which separate one living unit from another. The higher the value of R'_{w} , the higher the performance of the floor in terms of insulation against airborne noise.

Insulation against noise caused by footsteps, on the other hand, is defined by the parameter L'_{nw} (ITC - Impact Insulation Class for Canada and USA). This parameter characterises the capacity of a floor installed in a building to reduce impact noise.

The measurement of L'_{nw} is assessed by using a machine which simulates footsteps on the floor to be analysed, and measuring the level of noise received in the room below the floor. Therefore, the lower the value of noise measured (L'_{nw}) (ITC = 110 - L'_{nw} in compliance with Canadian and US standards), the better the performance of the floor regarding the reduction of noise. The procedures applied to carry out measurements are described in EN ISO 140-7:2000.

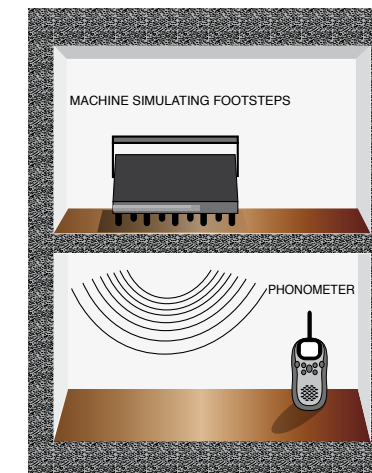

Each different country has specific domestic norms determining passive acousting requirements for building with different limitations.

Thermal comfort

In many countries, apart from soundproofing capacity, thermal insulation requirements are necessary. They must respect all the vertical and horizontal elements which separate buildings or adjacent housing units.

The insulation capacity of a given element is known as “thermal transmittance” (U) and is expressed in Watts per square metre Kelvin ($W/m^2 K$). The lower this value, the higher the thermal insulation capacity of a given element.



Noise: what a nuisance!

The dictionary defines noise as: “any noise or acoustic phenomenon which is unpleasant, fastidious, invasive and harmful to the human ear, and which is produced by an irregular formation of vibrations with no regular frequency”.

The dictionary of opposites, on the other hand, defines noise as: “calmness, peacefulness, silence and quiet”.

Unfortunately, the experience of acoustic pollution is not limited to the outside, but may also occur in buildings for housing or industry, where noise from equipment or normal activities carried out by people is transmitted from one housing unit to another, thereby reducing the comfort in living and working environments.

The problem of acoustic pollution is tackled by installing systems and materials which are employed to reduce the transmission of noise.

Noise is measured in decibels (dB), which is a way of quantifying to what extent the sensation of noise really disturbs people: the higher the level of noise measured in dB, the higher the level of disturbance it provokes.



Soundproofing system

From MAPEI research Mapesilent®

Soundproofing system to combat noise caused by footsteps

Over the years, the interest in the concept of living comfort has become more and more widespread. Clients and final users expect concrete performance levels and characteristics from buildings, and expect designers to guarantee solidity, a long service life, environmental sustainability, energy efficiency and living comfort, which is most clearly achieved, with efficient soundproofing.

Whether considering a residential building or a hotel under renovation, or a newly designed condominium or office block, designers, building companies and suppliers of building materials have to respect strict design criteria defined by the local standards in force in every country, which determine the minimum level of soundproofing in buildings.

Mapesilent® is MAPEI's answer to the increasing demand for efficient, guaranteed soundproofing systems to combat the noise of footsteps.

Our commitment to the environment

MAPEI has always been committed to the research and development of products which have the capacity of safeguarding the environment and meeting the latest requirements of the construction industry.



The Green Innovation trademark identifies those products with characteristics which offer an important contribution to sustainable building:

- Products with an extremely low emission level of volatile organic compounds
- Products with an extremely low emission level of dust during storage and mixing operations
- Products which, if applied in damp environments, block the formation of mould
- Products which contribute to the improvement of living comfort, for example by improving soundproofing against the noise caused by footsteps
- Products based on the use of raw materials from recycled ingredients which reduce the impact on the environment caused by the extraction of virgin materials
- Products which are a determining factor in the reduction of energy consumption
- Emission of low levels of CO₂ during their production

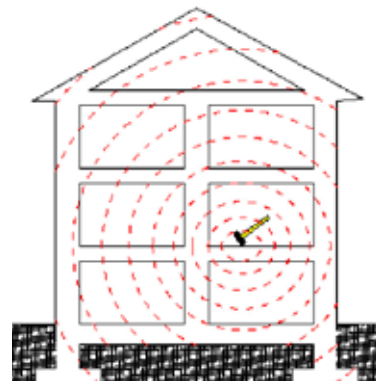

If there is no soundproofing system present, sound waves which act on the surface are free to spread through the entire, load-bearing structure of the building

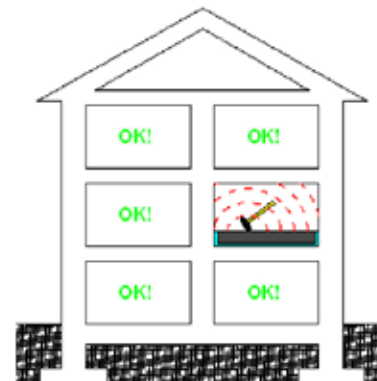

A floating floor completely isolates the surface from the structure so noise cannot spread.

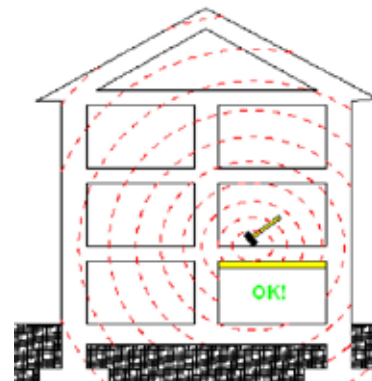

False ceiling only come into force in loud environments, and only reduce the direct transmission of noise, but not lateral noise.

Soundproofing: the answer

Isolated screed

Floors are the horizontal separating elements which must meet the requirements of thermal insulation and soundproofing as described in the previous pages. Screeds are normally cast on floors.

Screeds are constructive elements which vary in thickness from 4 to 8 cm, and are made from mortar mixed with cementitious binders or from anhydrite. According to how the screed is laid, directly on a supporting structure, on an isolating layer (for example a vapour barrier) or on a layer of thermal insulation or soundproofing, it is called a "bonded", "isolated" or "floating" screed.

If heating elements are also embedded, it is called a "heated" screed.

A screed forms a suitable substrate for any type of finishing material, whether ceramic, stone, wood or resilient. It must guarantee that floor-laying is carried out within the time required and guarantee that it is long-lasting under various conditions during its service life.

It is unlikely that a dividing element formed in such a way (load-bearing structure and screed) meets the minimum requirements of thermal insulation and soundproofing.

In order to meet the requirements of current legislation, the best solution is to lay an insulating material below the screed, which completely "isolates" it from the side structures and the substrate. This solution forms a "floating" screed which reduces vibrations generated by footsteps and increases its soundproofing properties against airborne noise from the load-bearing floor.

The insulating material also helps to improve thermal insulation of the floor.

Apart from offering the prescribed soundproofing characteristics, the insulating material must also be easy to install to reduce the risk of mistakes to a minimum, which would otherwise compromise the efficiency of the entire system. The insulating material must also be resistant to the passage of workmen or impacts which may occur when being installed on site before applying the screed, and must be easy to join on horizontal surfaces and around the edges, to avoid the formation of thermal and acoustic bridges.

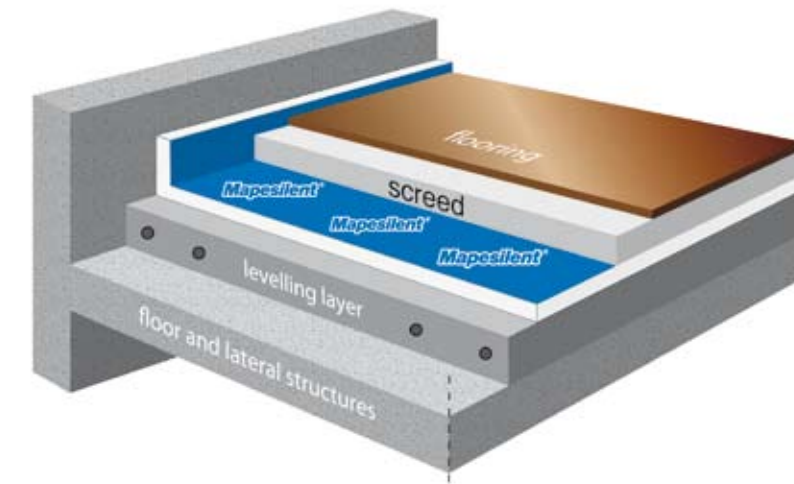

Stratification of a MAPESILENT floor and screed

Mapesilent: the components in the system

MAPEI has perfected a modular membrane system for thermal insulation and soundproofing, the **Mapesilent®** system. The **Mapesilent®** system allows floating screeds which are perfectly isolated from the substrate to be created simply and efficiently and, thanks to the characteristics of the materials which make up the system, to meet the requirements of current legislation regarding both soundproofing and thermal insulation.

Mapesilent® Roll

Elasto-plastomeric polymer bitumen membrane, joined to blue-coloured non-woven fabric and a layer of polyester fibre, available in 10 m x 1 m rolls in a thickness of 8 mm.

Mapesilent® Panel

Tiles formed by an elasto-plastomeric polymer bitumen membrane, joined to non-woven fabric and a layer of polyester fibre, available in handy 1 m x 1 m tiles in a thickness of 13 mm.

Mapesilent® Band

L-shaped adhesive, closed-cell, expanded polyethylene membrane applied to perimeter walls and around the edges of elements which pass through screeds to avoid the formation of acoustic bridges.

Mapesilent® Band is applied to all the walls around the perimeter of the screed, to form a soundproofing system with **Mapesilent® Panel** and **Mapesilent® Roll**, and around all the edges of elements which pass through the screed to avoid the formation of acoustic bridges. This product is available in two heights, 100 and 160 mm, called **Mapesilent® Band 50/100** and **Mapesilent® Band 50/160** respectively. The 160 mm version is required for heated floors where insulating panels are used, which incorporate the elements of the heating system.

Mapesilent® Door

U-shaped adhesive, closed-cell, expanded polyethylene membrane applied in correspondence with openings in perimeter walls to avoid the formation of acoustic bridges.

Mapesilent® Door is applied to all the openings in perimeter walls around the screed, to form a soundproofing system with **Mapesilent® Panel** and **Mapesilent® Roll**.

Mapesilent® Tape

Adhesive butyl rubber sealing tape with a silver-coloured surface, used to seal all the overlaps between various pieces of **Mapesilent® Band**, and to cover and join overlaps between **Mapesilent® Band** and **Mapesilent® Panel** (or **Mapesilent® Roll**) and all the joints between **Mapesilent® Panel** tiles and overlaps between rolls of **Mapesilent® Roll**.



Advantages of the **Mapesilent®** system

• EASY TO LAY

Allows for a quick and extremely simple installation of a continuous insulating layer without acoustic bridges. Its special conformation allows for easy checking of the position of the panels and sheets so that a continuous isolating layer may be formed.

• APPLICATION FLEXIBILITY

The two types of membrane available allow 5 different system configurations to be formed, according to the thermal-acoustic performance required from the system.

• EXCELLENT RESISTANCE TO FOOT TRAFFIC

During the phase before laying the screed, the product's high resistance protects the continuous layer and, therefore, its insulating capacity, from being damaged by foot traffic and/or accidental impact due to dropped tools.

• WATERPROOFING CAPACITY

The membranes of the **Mapesilent®** system are waterproof and, therefore, also form a waterproof safety layer for the screed against flooding or leaks.

• COMPLETE SYSTEM

Mapesilent® is a complete system with all the necessary accessories to form an efficient thermal insulation/soundproofing system.

• CERTIFIED SYSTEM

The **Mapesilent®** system is certified according to current international standards (EN ISO 140-1:2006, EN ISO 140-8:1999, EN ISO 717-2:2007, EN 29052-1:1993, EN 29053:1993).

Advantages of the **Mapesilent® Panel** system

Apart from the characteristics in common with other products in the **Mapesilent®** system, its superior insulating capacity and availability in 1 x 1 m panels make **Mapesilent® Panel** an efficient solution in environments such as:

- Small rooms where it is difficult to unroll and cut the membrane, thus increasing the time required to install the soundproofing system.



- Floors with a low soundproofing capacity. **Mapesilent® Panel** has a thicker layer of polyester fibre (10 mm) which means it has a lower level of dynamic stiffness ($S' = 21 \text{ MN/m}^3$) and, therefore, a higher soundproofing capacity ($\Delta L_w = 28.0 \text{ dB}$).



Typical application examples

- Floors with a low thermal insulation capacity. Thanks to the higher thickness of the polyester fibre (10 mm), **Mapesilent® Panel** also has the capacity of modifying the transmittance level (U) of a floor/screed, such as the example illustrated (see table on page 13) from a value of 0.97 W/m²K to a value of 0.75 W/m²K.



Fundamental values

Dynamic stiffness and noise caused by footsteps

1) Dynamic stiffness (S') – defines a material's capacity to be elastically deformed when subject to dynamic stress. This capacity, together with the presence of a floating screed, allows vibrations transmitted through a surface being walked on to be absorbed, thus reducing noise.

Dynamic stiffness is measured in MN/m³. The lower the value, the higher its capacity of absorbing noise. However, it is also important that its value is not so low that it compromises the thickness of the insulating material under load, and provokes resonance within the system. S'_i indicates the apparent dynamic stiffness of the material, while S' measures the dynamic stiffness of the material without any gas content (normally air), subject to a load of 200 kg/m² for 21 days, as prescribed in EN 29052-1: 1993. The latter value is used in order to estimate the value of L'_{n,w} and reflects the characteristics of the material subject to static and/or dynamic pressure.

2) Reduction of noise caused by footsteps (ΔL_w) – this indicates the capacity of a soundproofing material to reduce the noise of footsteps directly on floors. This value is expressed in decibels (dB) and is directly correlated to S'.

An example of how to lay Mapesilent® Panel



- 1 SLAB
- 2 DIVIDING WALL (**Mapesilent® Roll**)
- 3 LEVELLING LAYER ON LIGHTWEIGHT CONCRETE
- 4 **Mapesilent® Panel**
- 5 **Mapesilent® Tape**
- 6 **Mapesilent® Band**
- 7 SCREEDS MADE USING MAPECEM PRONTO OR TOPCEM PRONTO
- 8 FLOOR LAID WITH ADHESIVE ACCORDING TO EN 12004 STANDARDS
- 9 PERIMETER SKIRTING BOARDS

An example of how to lay Mapesilent® Roll



- 1 SLAB
- 2 DIVIDING WALL (**Mapesilent® Roll**)
- 3 LEVELLING LAYER ON LIGHTWEIGHT CONCRETE
- 4 **Mapesilent® Roll**
- 5 **Mapesilent® Tape**
- 6 **Mapesilent® Band**
- 7 SCREEDS MADE USING MAPECEM PRONTO OR TOPCEM PRONTO
- 8 FLOOR LAID WITH ADHESIVE ACCORDING TO EN 12004 STANDARDS
- 9 PERIMETER SKIRTING BOARDS

The following table shows the soundproofing performance of a brick-cement floor slab with each of the 5 configurations which may be obtained from the system by sandwiching the two types of membrane available

Floor slab isolated by sandwiching the materials

N°	Configurations MAPESILENT	m' _{slab} [kg/m ²]	L' _{n,w,eq} [dB]	m' _{screed} [kg/m ²]	S' [MN/m ³]	f ₀ [Hz]	ΔL _w [dB]	K [dB]	L' _{n,w} [dB]
1	MAPESILENT ROLL single layer	300	77,30	100	47	109.7	22.8	3	57.5
2	MAPESILENT ROLL double layer				23.5	77.6	27.3		53.0
3	MAPESILENT PANEL single layer				21	73.3	28.0		52.3
4	MAPESILENT ROLL + MAPESILENT PANEL				14.5	60.9	30.4		49.9
5	MAPESILENT PANEL double layer				10.5	51.8	32.5		47.8

- m'_{slab} = mass per unit of surface area of the slab
- L'_{n,w,eq} = level of sound pressure caused by footsteps of the slab
- m'_{screed} = mass per unit of surface area of a 5 cm thick screed
- S' = dynamic stiffness considered for calculation purposes (Σ S' sandwiched materials according to EN 12354-2:2002 standards)
- f₀ = resonance frequency of the system according to EN 12354-2 standards [f₀=160√(s'/m'_{screed})]
- ΔL_w = reduction index of the level of sound pressure caused by footsteps according to EN 12354-2 standards
- K = correction factor for lateral transmission
- L'_{n,w} = level of sound pressure caused by footsteps measured on the finished floor slab

The mass of the floor slab (m'_{slab}) was calculated according to the following configuration example: Lime-cement render (1 cm), brick-cement structure (2 + 4 cm), lightweight screed (600 kg/m³ - 7 cm) and floating screed in **Topcem Pronto®** (5.0 cm)

Designing an insulation system

Estimating the value of $L'_{n,w}$

For design purposes, there is a mathematical model which may be used to calculate the value theoretically:

$$L'_{n,w} = L_{n,weq} - \Delta L_w + K$$

where:

$L'_{n,weq}$ (dB) is the level of sound pressure caused by footsteps on the naked slab, without a floating screed.

ΔL_w (dB) indicates the reduction in noise caused by footsteps after installing a floating screed.

K (dB) is a corrective factor used to also consider the lateral transmission of noise.

The value depends on the surface mass of the naked slab and the surface mass of the vertical walls.

The following two tables illustrate the result of $L'_{n,w}$ according to variations in mass of the slab, using a screed with a hypothetical weight of 100 kg/m² (such as a 5 cm-thick screed in **Topcem Pronto**) and considering the use of **Mapesilent® Roll** or **Mapesilent® Panel**. A conservative value for the parameter K was chosen. The value illustrated must be considered merely as an indication when choosing which insulating system to adopt.

Mapesilent® Roll floor and floating screed

m'_{slab} (kg/m ²)	$L'_{n,weq} = 164 - 35 \log(m')$ (dB)	m'_{screed} (kg/m ²)	s' (Mapesilent® Roll) (MN/m ³)	f_0 (Hz)	ΔL_w (dB)	K (dB)	$L'_{n,w}$ (dB)
300	77.30	100	47	109.7	22.8	3	57.5
320	76.32	100	47	109.7	22.8	3	56.6
340	75.40	100	47	109.7	22.8	3	55.6
360	74.53	100	47	109.7	22.8	4	54.7
380	73.71	100	47	109.7	22.8	4	53.9
400	72.93	100	47	109.7	22.8	4	53.1
420	72.19	100	47	109.7	22.8	4	52.4

Mapesilent® Panel floor and floating screed

m'_{slab} (kg/m ²)	$L'_{n,weq} = 164 - 35 \log(m')$ (dB)	m'_{screed} (kg/m ²)	s' (Mapesilent® Panel) (MN/m ³)	f_0 (Hz)	ΔL_w (dB)	K (dB)	$L'_{n,w}$ (dB)
300	77.30	100	21	73.3	28.0	3	52.3
320	76.32	100	21	73.3	28.0	3	51.3
340	75.40	100	21	73.3	28.0	3	50.4
360	74.53	100	21	73.3	28.0	3	49.5
380	73.71	100	21	73.3	28.0	3	48.7
400	72.93	100	21	73.3	28.0	3	47.9
420	72.19	100	21	73.3	28.0	3	47.2

m'_{slab} = mass per unit of surface area of the slab
 $L'_{n,weq}$ = level of sound pressure caused by footsteps of the slab
 m'_{screed} = mass per unit of surface area of a 5 cm thick screed
 s' = dynamic stiffness of **Mapesilent® Roll** and **Mapesilent® Panel** for calculation purposes
 f_0 = resonance frequency of the system according to EN 12354-2 standards [$f_0 = 160 \sqrt{s'/m'_{screed}}$]
 ΔL_w = reduction index of the level of sound pressure caused by footsteps according to EN 12354-2 standards
 K = correction factor for lateral transmission
 $L'_{n,w}$ = level of sound pressure caused by footsteps measured on the finished floor slab

Calculating thermal insulation

Two calculation examples for a floor with no thermal insulation or soundproofing are shown below. In the first case, the value of thermal transmittance (U) di 0.97 W/m²K. In the second

case, the same floor with thermal insulation and soundproofing using **Mapesilent® Panel**, has a different value of thermal transmittance (U), 0.75 W/m²K.

Example of floor without thermal insulation and soundproofing

	Material	Thickness (m)	Density (kg/m ³)	Conductivity (W/mK)	Surface mass (kg/m ²)	Resistance (m ² K/W)
<i>Upper internal surface</i>						0.1
1	Ceramic tiles	0.01	2000	1	20	0.01
2	Cementitious screed	0.05	2000	1.4	100	0.036
3	Lightweight concrete	0.07	600	0.16	42	0.438
4	Masonry and cement floor 20 + 4	0.24			330	0.33
5	Render	0.01	1400	0.7	14	0.014
<i>Lower internal surface</i>						0.1
					R_{TOT} (m ² K/W)	1.03
					U_{TOT} (W/m ² K)	0.97
Total thickness (m)		0.38				

Example of floor insulated with Mapesilent® Panel

	Material	Thickness (m)	Density (kg/m ³)	Conductivity (W/mK)	Surface mass (kg/m ²)	Resistance (m ² K/W)
<i>Upper internal surface</i>						0.1
1	Ceramic tiles	0.01	2000	1	20	0.01
2	Cementitious screed	0.04	2000	1.4	80	0.029
3	Mapesilent® Panel	0.01		0.032		0.313
4	Lightweight concrete	0.07	600	0.16	42	0.438
5	Masonry and cement floor 20 + 4	0.24			330	0.33
6	Render	0.01	1400	0.7	14	0.014
<i>Lower internal surface</i>						0.1
					R_{TOT} (m ² K/W)	1.33
					U_{TOT} (W/m ² K)	0.75
Total thickness (m)		0.38				

Note: for safety reasons, the calculation considered the most restrictive values for surface thermal resistance (cfr. EN ISO 6946 par. 5)

Application

Application of the *Mapesilent*® system

Correct application and careful attention to the recommended procedures are essential to obtain good results from thermal insulation and soundproofing.

The way a “floating” screed system works follows a very simple concept. A flexible material with the capacity of absorbing vibrations is laid between the screed and the load-bearing floor, and between the screed and the side walls.

There are, however, certain critical points to consider when installing the system. In particular, the “basin” of insulating material must be infiltration proof. There must be no points of contact between the screed and the side structures such as rigid joints, known also as acoustic/thermal bridges, which would completely ruin the insulation from vibrations.

Inserting an isolating layer, such as a polyethylene sheet, may not necessarily be sufficient to guarantee that the system holds, especially if the sheet is laid dry on the soundproofing part, and overlaps are not sealed correctly.

The *Mapesilent*® system has been carefully developed to reduce problems to a minimum during installation. MAPEI’s experience in waterproofing products has led to the development of a range of products which are easy to install, and resistant to tears which may take place on site.

The sequence of operations to install the *Mapesilent*® system is described below.

Checking the substrate

A) Check that the substrate is flat and that there are no rough spots. Channels for cables or piping must be levelled off. If a lightweight screed is used to cover cable or pipe channels, make sure that it is installed evenly. Concentrations of material could cause cracks or fractures which would completely ruin insulation against the noise of footsteps.

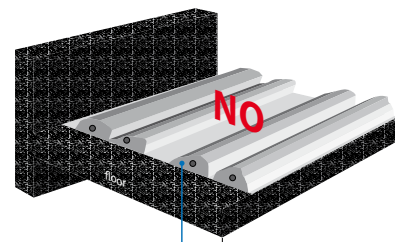

NOT CORRECT CHANNELS FOR CABLES OR PIPING

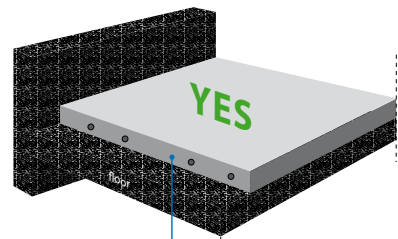

CORRECT CHANNELS FOR CABLES OR PIPING

B) Any excess material which makes the surface uneven must be removed.



C) Rubble must be removed before laying the material.



Mapesilent® Panel

A) Lay the *Mapesilent*® Panel tiles with the fibre layer (the light-coloured side) underneath, making sure they are perfectly aligned.



B) Once the alignment of the *Mapesilent*® Panel tiles has been checked, carefully seal all the joints using *Mapesilent*® Tape.



C) To guarantee that *Mapesilent*® Tape bonds perfectly, we recommend passing over the surface of the tape with a rigid or semi-rigid roller.



Mapesilent® Panel

D)

Cut the lower part of **Mapesilent® Band** to form a 90° angle and remove the protective backing film to expose the adhesive part.



E)

Position the 90° angle of **Mapesilent® Band** in order to check that the two sides of the cut match perfectly.



F)

Apply the various strips of **Mapesilent® Band** side by side. Remove the protective film and bond it around all the perimeter of the room.



G)

Apply **Mapesilent® Door** in correspondence with all the openings and make sure that it is perfectly in place.



Mapesilent® Panel

H)

Remove the protective backing film and bond **Mapesilent® Door** on the **Mapesilent® Panel** and on the walls.



I)

Blend in **Mapesilent® Door** with a strip of **Mapesilent® Tape**.

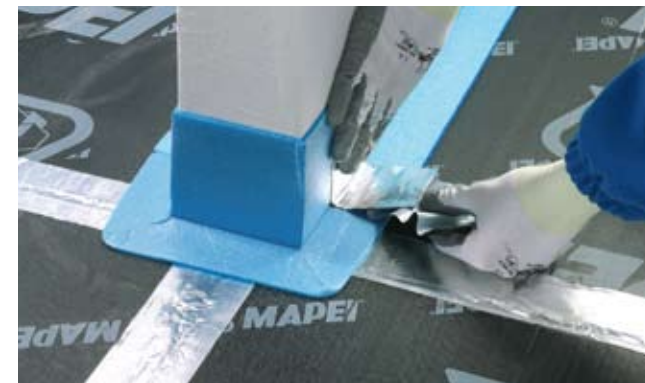

J)

Cut and apply **Mapesilent® Tape** in all the corners and around the blended-in areas of **Mapesilent® Band** to guarantee that the joints are perfectly protected.

K)

Apply **Mapesilent® Tape** along the overlaps of **Mapesilent® Panel** and **Mapesilent® Band**.



L)

Once work has been completed, the silver side of the **Mapesilent® Tape** must be visible on all the overlaps and joints of the **Mapesilent® Panel** and the **Mapesilent® Band**. There must be absolutely no contact points with the substrate, to avoid the formation of "acoustic bridges".



Mapesilent® Roll

- A)** Open the roll of **Mapesilent® Roll**, place it against the bottom of the wall and start laying it with the fibre side (the light-coloured side) underneath, following the longer side of the room.

- B)** Roll out the second sheet and place it against the bottom of the wall, making sure that it overlaps the first roll by at least 5 cm.



- C)** After checking that the sheets of **Mapesilent® Roll** overlap perfectly, seal all overlaps using **Mapesilent® Tape**.



- D)** To guarantee that **Mapesilent® Tape** bonds perfectly, we recommend passing over the surface of the tape with a rigid or semi-rigid roller.



Mapesilent® Roll

- E)** Cut the lower part of **Mapesilent® Band** to form a 90° angle.



- F)** Position the 90° angle of **Mapesilent® Band** in order to check that the two sides of the cut match perfectly.



- G)** Remove the protective backing film from the **Mapesilent® Band** and bond the strip of **Mapesilent® Roll** to the wall.



- H)** Apply the various strips of **Mapesilent® Band** side by side. Remove the protective film and bond it around all the perimeter of the room.



- I)** Apply **Mapesilent® Door** in correspondence with all the openings and make sure that it is perfectly in place.



Mapesilent® Roll

- J)** Remove the protective backing film and bond **Mapesilent® Door** on the **Mapesilent® Roll**, **Mapesilent® Band** and on the walls.



- K)** Cut and apply **Mapesilent® Tape** in all the corners and around the blended-in areas of **Mapesilent® Band** and **Mapesilent® Door** to guarantee that the joints are perfectly protected.



- L)** Apply **Mapesilent® Tape** along the overlaps of **Mapesilent® Band** and **Mapesilent® Roll**.



- M)** Once work has been completed, the silver side of the **Mapesilent® Tape** must be visible on all the overlaps and joints of the **Mapesilent® Roll** and **Mapesilent® Band**. There must be absolutely no contact points with the substrate, to avoid the formation of “acoustic bridges”.

Installing screeds

After completing application of the **Mapesilent®** insulating system, irrespective of whether **Mapesilent® Panel** or **Mapesilent® Roll**, have been used, the screed on which the final floor covering is to be laid may be installed immediately.



Special binders or pre-blended mortars from the MAPEI range may be used to make the screed:

- **Topcem**
Special hydraulic binder for normal setting, fast drying (4 days) and controlled shrinkage screeds.
- **Topcem Pronto**
Pre-blended ready-to-use mortar for fast drying (4 days) and normal setting screeds with controlled shrinkage of class CT-C30-F6-A1_{fl}, in compliance with EN 13813 and EC1R - very low emission level of volatile organic compounds.
- **Mapecem**
Special fast-setting and drying (24 hours), hydraulic binder for controlled shrinkage screeds.
- **Mapecem Pronto**
Pre-blended, ready-to-use, fast-setting and drying (24 hours), controlled-shrinkage mortar, of class CT-C60-F10-A1_{fl} in compliance with EN 13813.

The thickness of the screed and the type of reinforcement used must be chosen according to the type of traffic to which the surface will be subject when in service.

After waiting the prescribed curing time for the screed, which depends on the type of binder used and the type of flooring material to be used, the floor may be laid (ceramic tiles, stone, resilient and textiles, wood, etc.).

Finishing off skirting boards

A)

After laying and grouting the floor, cut off the excess parts of **Mapesilent® Band** and/or **Mapesilent® Door**.



B)

Seal the spaces between the skirting boards and the floor with a suitable flexible sealant such as **Mapesil AC**, after applying **Primer FD**.



Radiating heated floors

Once installed, the **Mapesilent®** system must not be interrupted or perforated by cables or pipe-work, to guarantee perfect soundproofing and that it is isolated from the screed.

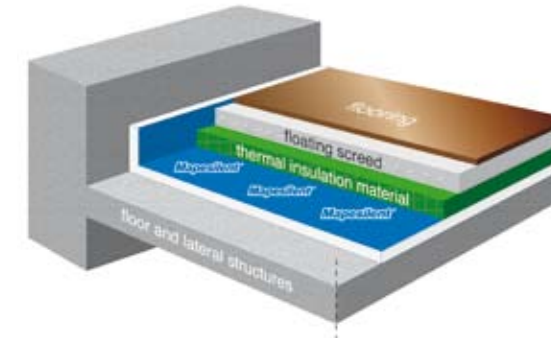

Position of Mapesilent® in radiating heated floors

If floor-heating systems are used (radiant heating panels), we recommend installing the **Mapesilent®** system below the thermal insulation layer. The presence of an insulating layer, which must be positioned therefore on the inside face of the floating screed, requires the use of **Mapesilent® Band 50/160** with a thicker vertical edge.

Mapesilent® Band 50/160 may be used instead of compressible polyethylene strip, which is normally applied around the perimeter of rooms before laying screeds.

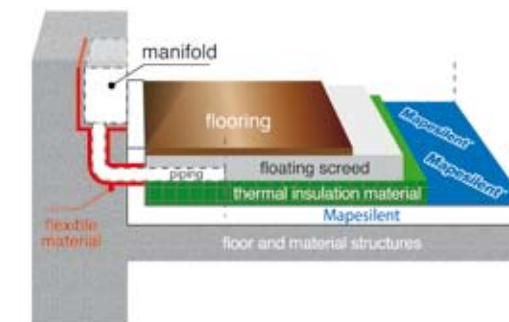

Correct position of manifold boxes

To avoid the formation of acoustic bridges, which are generated by contact between the external vertical partitions and the inter-connecting pipe-work between the heating elements and the manifold located on the wall, it is extremely important that every single element which protrudes from the floating screed is lagged with flexible material. **Mapesilent® Roll** or **Mapesilent® Band** may be used to isolate these elements, including the manifold itself. In apartments, we recommend putting the piping manifolds in corridors.

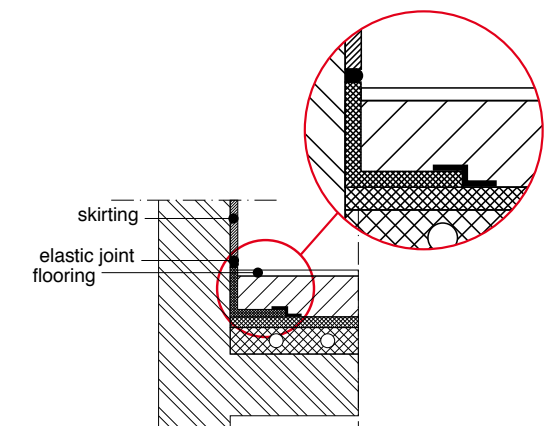
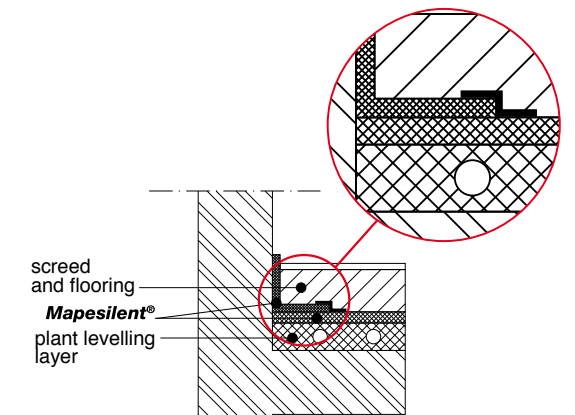
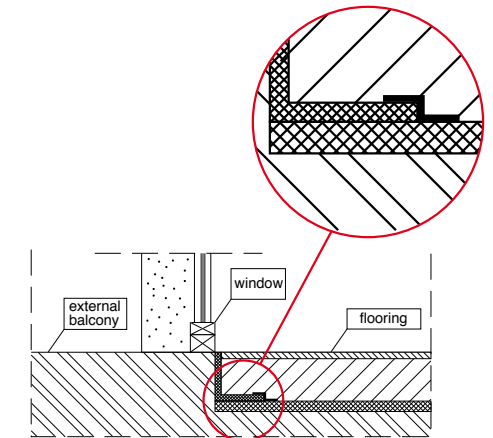

Technical drawings

Solution 1 - Floating flooring

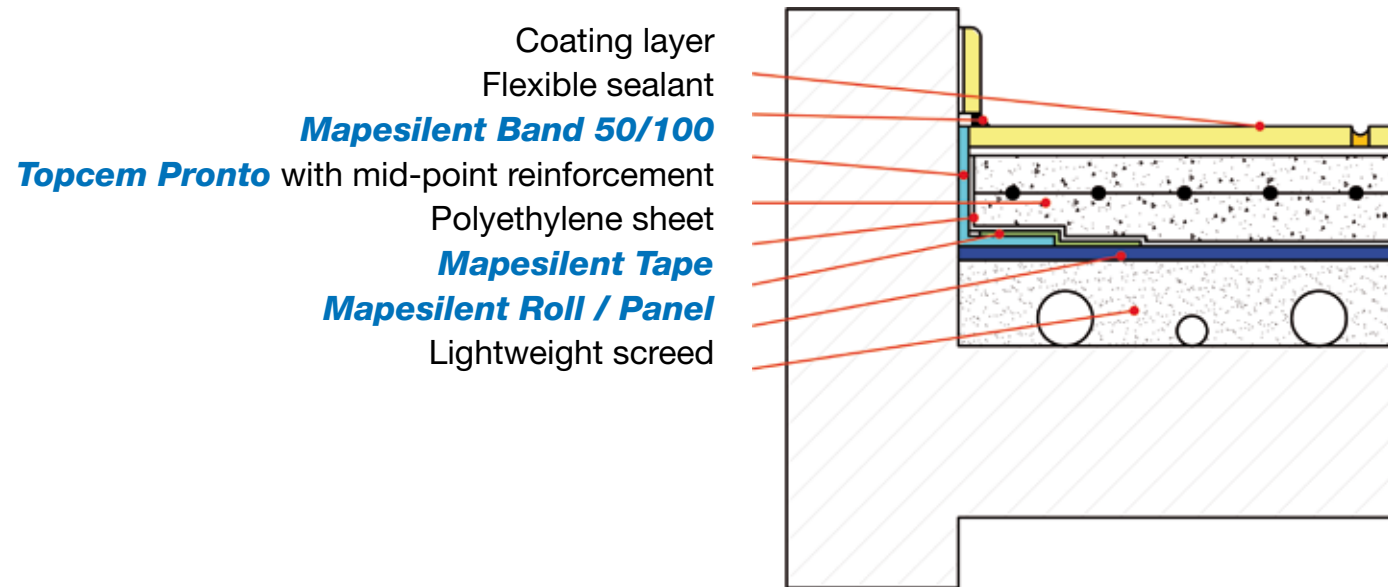

Solution 2 - Heated flooring

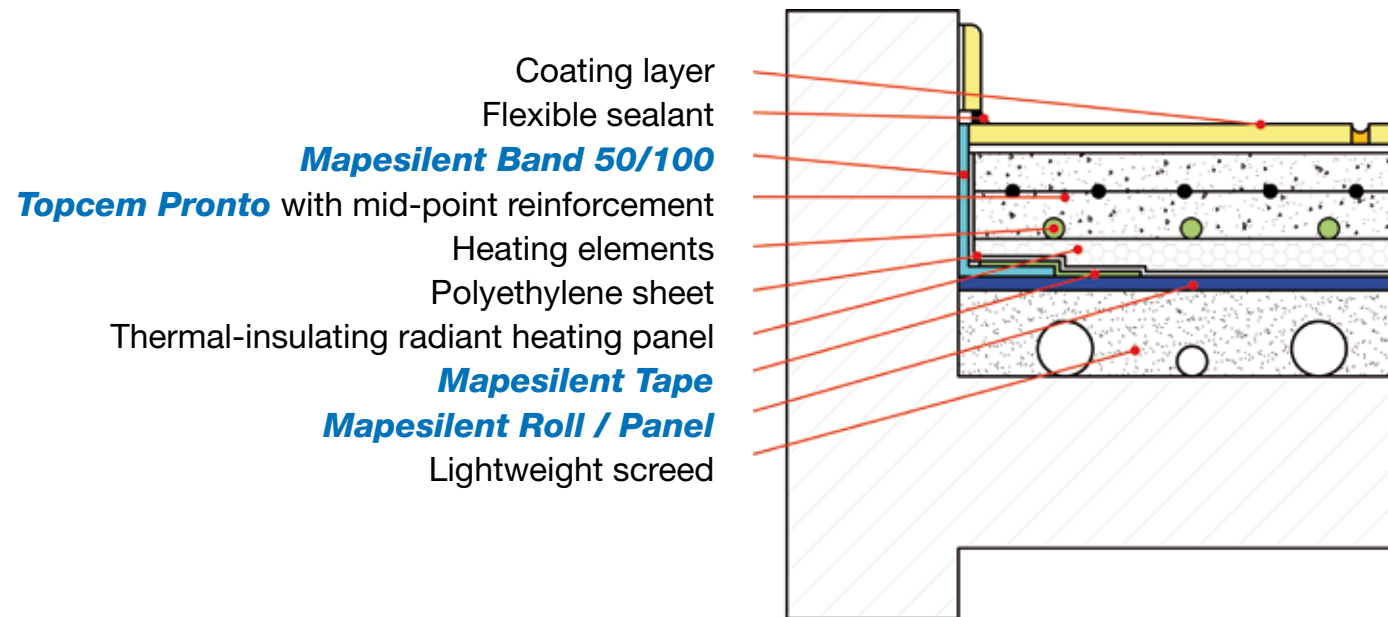

Solution 1 - Terrace

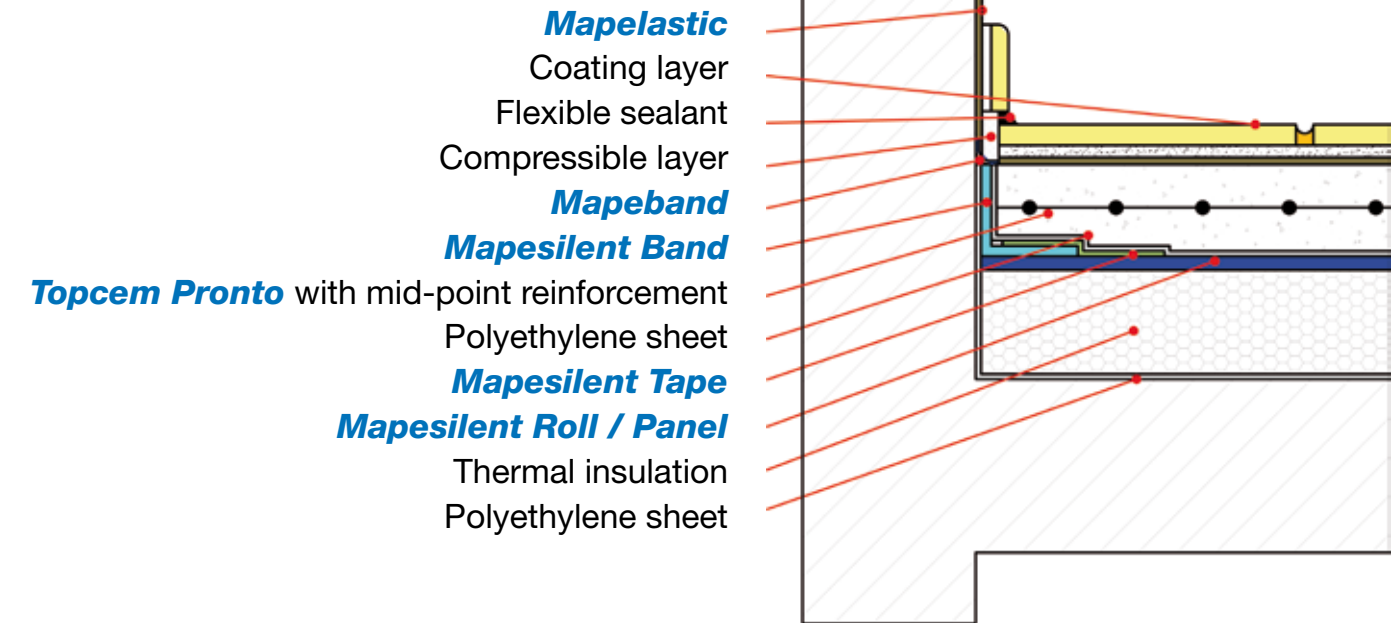

Laboratory measurements

Dynamic stiffness (S') Mapesilent® Roll

(Allegato "A" al rapporto di convalida n. 256817 del 29/06/2009) segue - foglio n. 3 di 3

ISTITUTO GIORDANO

La rigidità dinamica per unità di superficie del gas contenuto al suo interno può essere calcolata con l'equazione seguente in cui d è lo spessore sotto carico, pari a 3,5 mm:

$$s'_a = \frac{111}{d}$$

Da una verifica sperimentale effettuata sulla sola componente fibrosa, la presenza dello strato bituminoso risulta pressoché ininfluente, la sua rigidità dinamica è risultata molto superiore a quella delle altre componenti. Nel contesto descritto, la rigidità dinamica totale effettiva del materiale "s'" è fornita dalla relazione:

$$s' = (s'_1 + s'_{a2})$$

dove: s'₁ = rigidità dinamica apparente del campione, espressa in MN/m³;
s'_{a2} = rigidità dinamica del gas contenuto nello strato in fibra di poliestere, espressa in MN/m³.

Risultati.

Rigidità dinamica apparente media "s' ₁ " del campione	15 MN/m ³
Rigidità dinamica dell'aria media "s' _{a2} " fibra di poliestere	32 MN/m ³
Rigidità dinamica effettiva media "s'" del campione	47 MN/m³

Il Responsabile Tecnico di Prova (Dott. Andrea Bruschi) e il Responsabile del Laboratorio di Acustica e Vibrazioni (Dott. Ing. Roberto Baruffa) sono firmati e sigillati con il sigillo del Laboratorio di Acustica e Vibrazioni.

Il Presidente o l'Amministratore Delegato (L'AMMINISTRATORE DELEGATO) è firmato e sigillato con il sigillo del Laboratorio di Acustica e Vibrazioni.

Laboratory measurements

Dynamic stiffness (S') Mapesilent® Panel

I.N.R.I.M.
ISTITUTO NAZIONALE DI RICERCA METROLOGICA

RAPPORTO DI PROVA
N. 09-0124-02 emesso il 2009-02-17 - pag. 4/4

MAPESILENT PANEL



Figura 2

Condizioni ambientali al momento della prova:

- Temperatura dell'aria: 17 °C
- Umidità relativa dell'aria: 32 %

3. RISULTATI DI MISURA

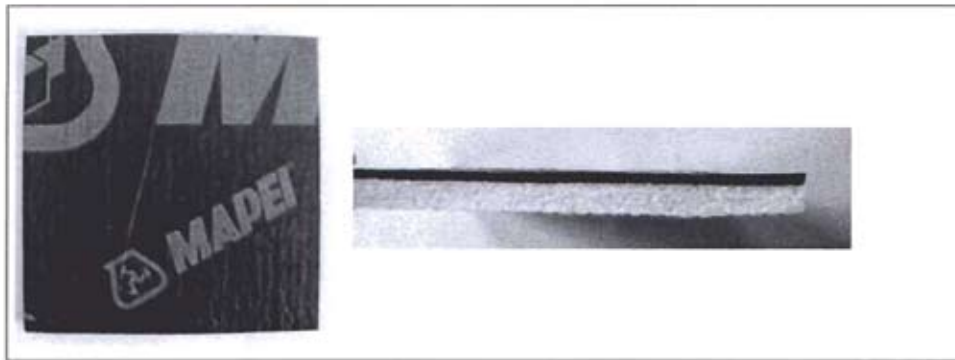
I risultati sono riportati nella tabella 1. L'incertezza estesa U è espressa come l'incertezza tipo moltiplicata per il fattore di copertura k = 2, che per una distribuzione normale corrisponde ad una probabilità di copertura di circa il 95 %.

La misura è stata effettuata dopo 5 giorni dall'applicazione della piastra di carico.

Tabella 1

Frequenza di risonanza:	f _r = 36 Hz U = 4 Hz
Resistenza al flusso d'aria media:	r = 24 kPa · s/m ² U = 0,5 kPa · s/m ²
Rigidità dinamica dell'aria contenuta all'interno del provino:	s' _a = 11 MN/m ³
Rigidità dinamica apparente per unità di superficie:	s' ₁ = 10 MN/m ³ U = 1 MN/m ³
Rigidità dinamica per unità di superficie:	s' = 21 MN/m ³ U = 1 MN/m ³

Controllato: *Andrea Pavoni*
(Andrea Pavoni Belli)

Laboratory measurements

Reduction of transmitted impact noise on standard floor slab insulated with Mapesilent® Roll

Laboratory measurements

Reduction of transmitted impact noise on standard floor slab insulated with Mapesilent® Panel

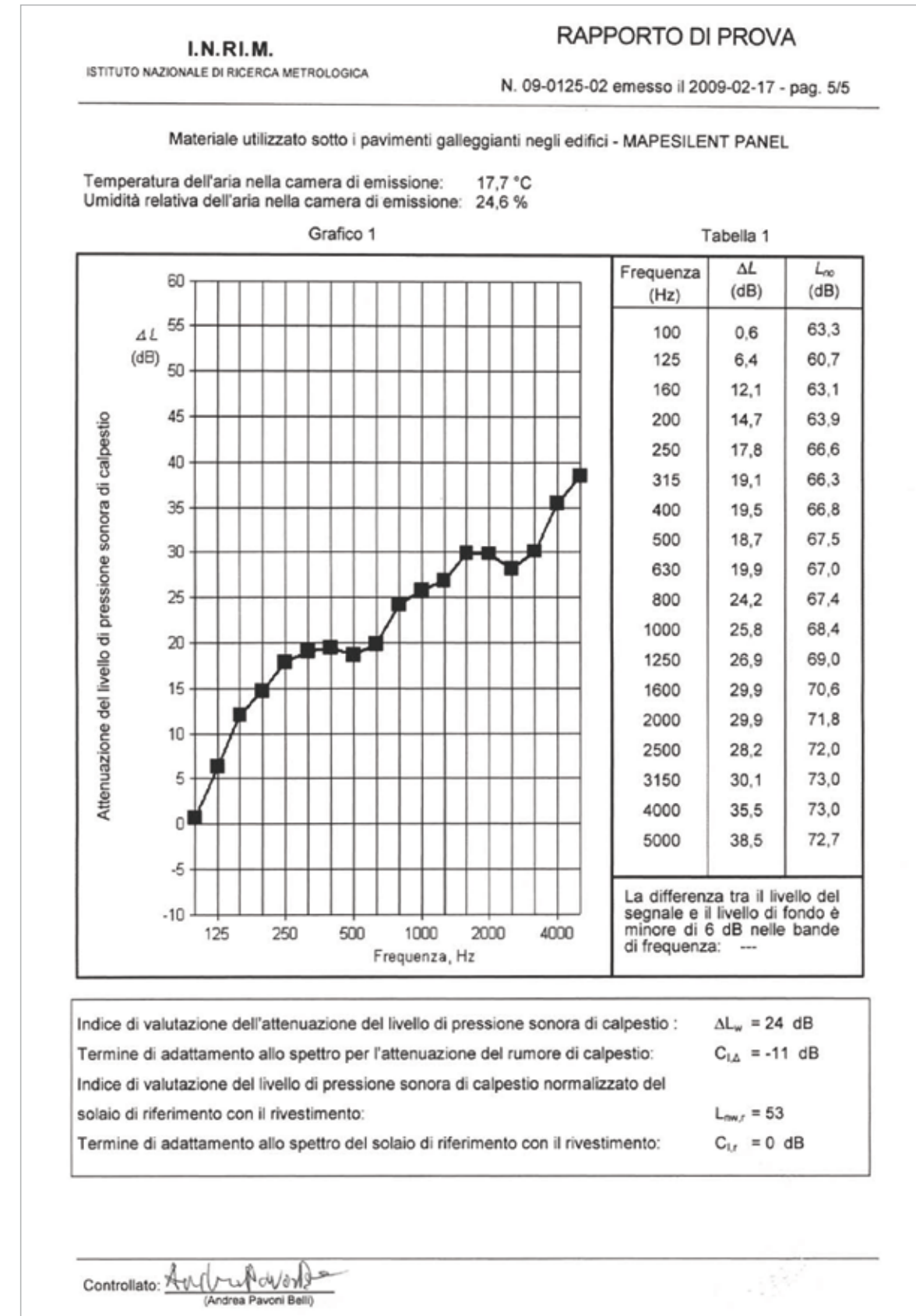
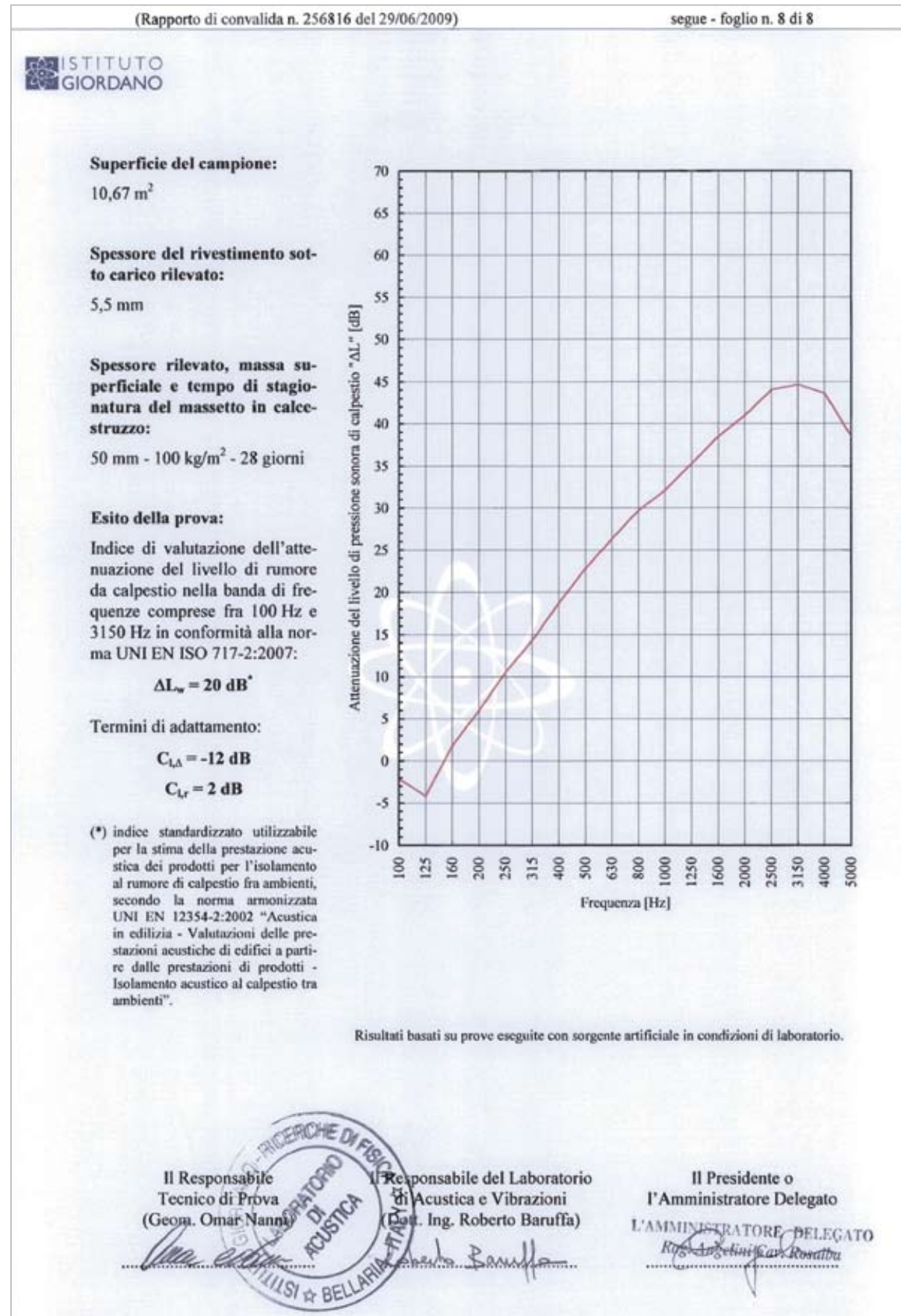

Please note: the improvement in soundproofing illustrated by the above tests was carried out on a 14 cm-thick reinforced cement floor slab with an area of 10 m², in exact compliance with the specifications prescribed by current standards (EN ISO 140-8:1999 e EN ISO 717-2:2007).

On-site measurements

Anit Certificate - Naked slab

As demonstrated by the certificates issued by technicians from the Milan section of ANIT (National Association of Thermal Insulation and Soundproofing), following on-site measurements taken both before and after installation of a floating screed in a residential building in Busto Arsizio

(Varese, Italy) on top of a 20+5 cm brick-cement floor slab insulated with a layer of **Mapesilent® Roll**, excellent results may be obtained if the soundproofing layer is installed correctly, as confirmed by the decrease in noise caused by footsteps (ΔL_w) in the order of 30 dB.

Isolamento dal rumore di calpestio secondo la UNI EN ISO 140-7 (Dicembre 2000)																																													
"Misurazione in opera dell'isolamento dal rumore di calpestio di solai"																																													
Misurazioni effettuate da: TEP S.r.l. Via Matteo Civitali, 77 - 20148 Milano Tel: 02-40070208	Cliente: MAPEI spa VIA CAFIERO 22 20158 MILANO (MI)																																												
Data della prova: 09/02/2009																																													
Descrizione solaio esaminato: Edificio a Busto Arsizio (VA) - Macchina da calpestio poggiata sul solaio portante tra i piani P2/P1 Solaio laterocemento 20+5 intonacato sul lato inferiore																																													
Volume ambiente ricevente: <input type="text" value="39.1"/> mc																																													
<table border="1"> <thead> <tr> <th>Frequenza f [Hz]</th> <th>L'n Terzo di ottava [dB]</th> </tr> </thead> <tbody> <tr><td>50</td><td></td></tr> <tr><td>63</td><td></td></tr> <tr><td>80</td><td></td></tr> <tr><td>100</td><td>60.8</td></tr> <tr><td>125</td><td>63.7</td></tr> <tr><td>160</td><td>65.2</td></tr> <tr><td>200</td><td>64.9</td></tr> <tr><td>250</td><td>66.4</td></tr> <tr><td>315</td><td>67.4</td></tr> <tr><td>400</td><td>68.3</td></tr> <tr><td>500</td><td>68.3</td></tr> <tr><td>630</td><td>68.5</td></tr> <tr><td>800</td><td>70.8</td></tr> <tr><td>1000</td><td>72.0</td></tr> <tr><td>1250</td><td>74.2</td></tr> <tr><td>1600</td><td>74.9</td></tr> <tr><td>2000</td><td>77.4</td></tr> <tr><td>2500</td><td>81.6</td></tr> <tr><td>3150</td><td>81.1</td></tr> <tr><td>4000</td><td></td></tr> <tr><td>5000</td><td></td></tr> </tbody> </table>	Frequenza f [Hz]	L'n Terzo di ottava [dB]	50		63		80		100	60.8	125	63.7	160	65.2	200	64.9	250	66.4	315	67.4	400	68.3	500	68.3	630	68.5	800	70.8	1000	72.0	1250	74.2	1600	74.9	2000	77.4	2500	81.6	3150	81.1	4000		5000		
Frequenza f [Hz]	L'n Terzo di ottava [dB]																																												
50																																													
63																																													
80																																													
100	60.8																																												
125	63.7																																												
160	65.2																																												
200	64.9																																												
250	66.4																																												
315	67.4																																												
400	68.3																																												
500	68.3																																												
630	68.5																																												
800	70.8																																												
1000	72.0																																												
1250	74.2																																												
1600	74.9																																												
2000	77.4																																												
2500	81.6																																												
3150	81.1																																												
4000																																													
5000																																													
Note:																																													
Valutazione secondo ISO 717 - 2: $L'_{n,w} = $ <input type="text" value="85.0"/> dB $C_1 = $ <input type="text" value="-13"/> dB Valutazione basata su risultati di misurazioni in opera																																													
Data: 18/11/2008	Firma: Ing. Matteo Borghi 																																												

On-site measurements

Anit Certificate - Finished flooring (slab + floating screed)

Isolamento dal rumore di calpestio secondo la UNI EN ISO 140-7 (Dicembre 2000)																																													
"Misurazione in opera dell'isolamento dal rumore di calpestio di solai"																																													
Misurazioni effettuate da: TEP S.r.l. Via Matteo Civitali, 77 - 20148 Milano Tel: 02-40070208	Cliente: MAPEI spa VIA CAFIERO 22 20158 MILANO (MI)																																												
Data della prova: 26/03/2009																																													
Descrizione solaio esaminato: Edificio a Busto Arsizio (VA) - Macchina da calpestio poggiata sul solaio tra i piani P2/P1 Solaio laterocemento 20+5 intonacato sul lato inferiore, massetto alleggerito sp. 6 cm, MAPESILENT ROLL, massetto TOPCEM PRONTO sp. 4,5 cm, piastrelle																																													
Volume ambiente ricevente: <input type="text" value="38.1"/> mc																																													
<table border="1"> <thead> <tr> <th>Frequenza f [Hz]</th> <th>L'n Terzo di ottava [dB]</th> </tr> </thead> <tbody> <tr><td>50</td><td></td></tr> <tr><td>63</td><td></td></tr> <tr><td>80</td><td></td></tr> <tr><td>100</td><td>55.0</td></tr> <tr><td>125</td><td>60.0</td></tr> <tr><td>160</td><td>57.2</td></tr> <tr><td>200</td><td>53.5</td></tr> <tr><td>250</td><td>51.9</td></tr> <tr><td>315</td><td>55.9</td></tr> <tr><td>400</td><td>56.5</td></tr> <tr><td>500</td><td>52.4</td></tr> <tr><td>630</td><td>52.1</td></tr> <tr><td>800</td><td>53.0</td></tr> <tr><td>1000</td><td>51.3</td></tr> <tr><td>1250</td><td>51.3</td></tr> <tr><td>1600</td><td>48.6</td></tr> <tr><td>2000</td><td>46.8</td></tr> <tr><td>2500</td><td>47.9</td></tr> <tr><td>3150</td><td>45.3</td></tr> <tr><td>4000</td><td></td></tr> <tr><td>5000</td><td></td></tr> </tbody> </table>	Frequenza f [Hz]	L'n Terzo di ottava [dB]	50		63		80		100	55.0	125	60.0	160	57.2	200	53.5	250	51.9	315	55.9	400	56.5	500	52.4	630	52.1	800	53.0	1000	51.3	1250	51.3	1600	48.6	2000	46.8	2500	47.9	3150	45.3	4000		5000		
Frequenza f [Hz]	L'n Terzo di ottava [dB]																																												
50																																													
63																																													
80																																													
100	55.0																																												
125	60.0																																												
160	57.2																																												
200	53.5																																												
250	51.9																																												
315	55.9																																												
400	56.5																																												
500	52.4																																												
630	52.1																																												
800	53.0																																												
1000	51.3																																												
1250	51.3																																												
1600	48.6																																												
2000	46.8																																												
2500	47.9																																												
3150	45.3																																												
4000																																													
5000																																													
Note:																																													
Valutazione secondo ISO 717 - 2: $L'_{n,w} = $ <input type="text" value="55.0"/> dB $C_1 = $ <input type="text" value="-4"/> dB Valutazione basata su risultati di misurazioni in opera																																													
Data: 26/03/2009	Firma: Ing. Matteo Borghi 																																												

SOUNDPROOFING SYSTEM TO REDUCE NOISE TRANSMITTED BY FOOTSTEPS

HEADQUARTERS

MAPEI SpA

Via Cafiero, 22 - 20158 Milan

Tel. +39-02-37673.1

Fax +39-02-37673.214

Internet: www.mapei.com

E-mail: mapei@mapei.it

