



specification & selection guide

EVO

235
270

evo fan coil system



EVO Fan Coil

Ability Projects, recognising the potential of EC/DC motors, introduced the first EC/DC fan coil product in 2002. Initial reactions were very favourable but sales were limited to customers that had an overwhelming need for, or desire for, the energy efficiency benefits that EC/DC fan coils could bring.

Then in 2007, the new building regulations included for the first time a limiting power consumption for many products, amongst which were fan coils. It was at this point the corner was turned in that, for the first time consideration for energy reduction was not a 'nice to have', it was necessary. Since then, the regulations have tightened once more and the likelihood is there will be further reductions in the future. However, this is not a problem for Ability as the next generations of even more efficient products are already available.

Since those early projects, the EC/DC motor has gone through an evolution of its own, fine tuning it to the performance characteristics of fan coils and making it far more cost effective. Consequently, we now have a total fan coil solution providing exceptional reliability, best in class energy efficiency, low noise and now - pressure independent water flow control.

Pressure independent control valves are far more commonplace. However, the Ability pressure independent valve solution is unique in that the valve position is set through software, not physically at the valve. This means that flow rate checking and flow rate changes do not require a physical adjustment at the fan coil minimising disruption as the project approaches handover.

With the move towards 'Soft Landed' projects, in other words projects that are commissioned and handed over through a period of time, rather than at a point in time, the remote adjustment capability of the Ability solution becomes invaluable.

The ultimate fan coil from Ability also incorporates, pressure independent, self-balancing air volumes. Please refer to our separate Matrix Brochure.



Corporate

Ability Projects specialise in the design and manufacture of UK specification fan coil units (FCU's) and are one of the UK's pre-eminent suppliers. A privately owned company trading since 2001, Ability were the first FCU supplier to embrace EC/DC technology which is at the heart of the EVO range. Ability Projects are based in a 30,000 sq foot factory on the south coast of the UK and operates a fully integrated sales, design and manufacturing facility.

For many years the UK fan coil has been at the forefront of design in terms of reliability, low noise and energy efficiency. It is the terminal unit of choice with most design engineers, so much so, that Ability are now exporting fan coil units all over the world.

Ability are proud to also manufacture the most energy efficient fan coil units in the market place today. Built around the EVO range, the Matrix Platform has culminated in the current Matrix³ product; more information can be found in the Matrix Brochure.

The Ability team has a great technical expertise, a vast experience of fan coil application and an enthusiasm to configure workable, effective fan coil packages. Your project may be large or small, standard or bespoke but all enquiries receive the same care and attention to detail.

Contents

4)	EC/DC Fans and Motors	14)	EVO 235 Thermal Performance
6)	Product Specification	15)	EVO 235 Sound Power Levels
8)	EVO 270 and 235 Overview	16)	EVO 235 Schematic
10)	EVO 270 Thermal Performance	18)	Acoustic Guide
11)	EVO 270 Sound Power Levels	20)	Installation Guide
12)	EVO 270 Schematic	24)	Controls Packages
		26)	Other Products and Services

EC/DC Fans & Motors

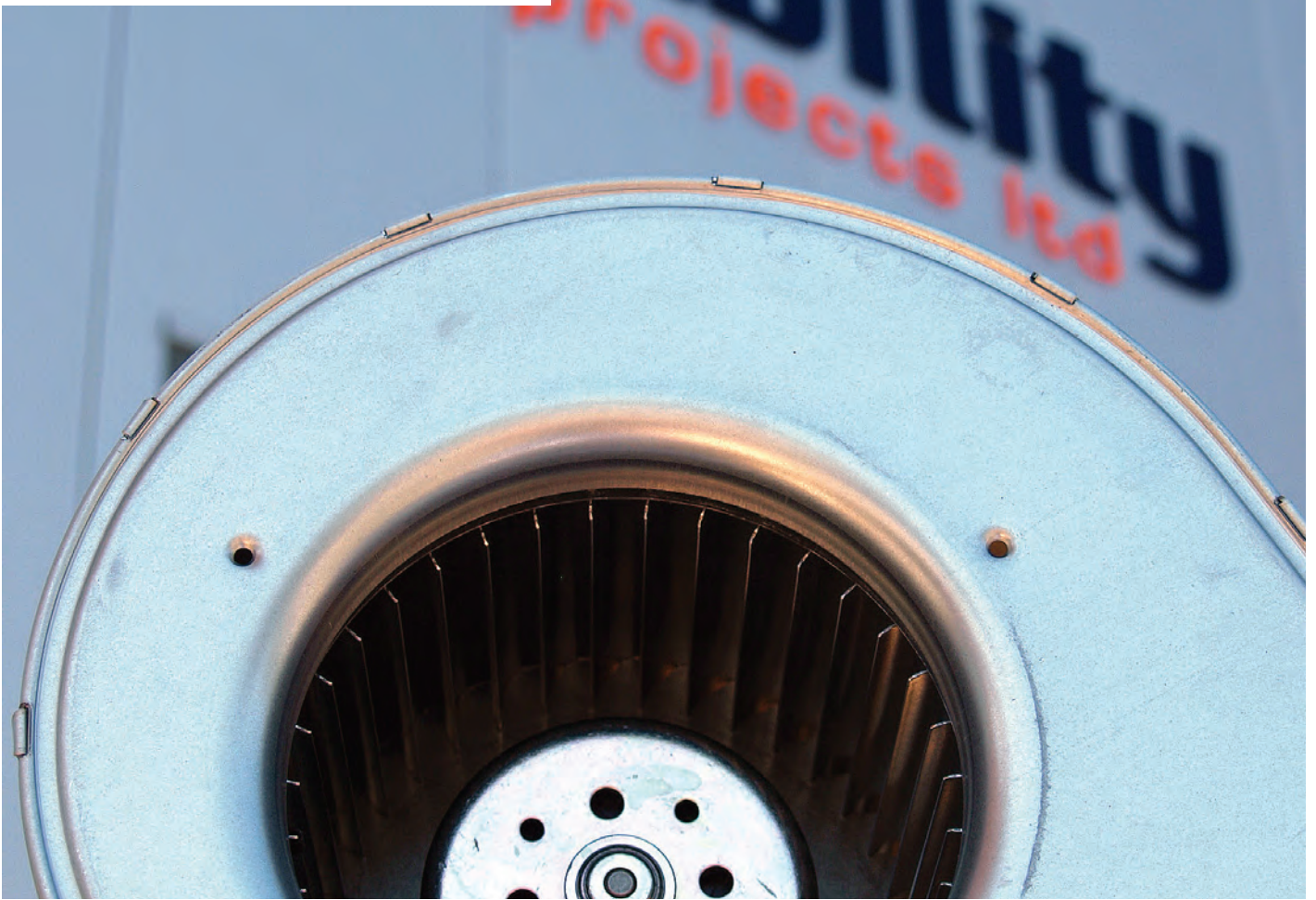

> The EVO Fan Motors

All the fan motors used in our EVO products are EC/DC. EC is Electronically Commutated and DC is, obviously, Direct Current. These motors offer a significant energy saving over their AC equivalents consuming about 45% of the power at the same duty point. However, EC/DC motor and fan sets offer even more savings if used with an intelligent variable speed strategy.

The standard EC/DC fans provide a unit in which the fan speed adjustments, necessary for air volume setting, are made by adjusting a 0-10 V DC control signal. This control signal can be provided by using either a manual, pre wired infinite speed switch, or it can alternatively come directly from the BMS (Building Management System). Using EC/DC motors with this form of speed control does bring tremendous energy savings but still requires commissioning conventionally.

Matrix fan coil units from Ability however, are pre-set with the required air volume per discharge duct run, and irrespective of duct resistance, will adjust their own fan speed to achieve the desired air volume and duct balance. Commissioning air volumes with Matrix is a checking exercise, not a setting exercise. If you are interested in Matrix please contact the office.

> Controllability

While EC/DC motors consume much less power than their AC counterparts they also allow VAV (Variable Air Volume) strategies to be employed which opens the door to further, substantial energy savings.

The relationship between power consumed (VA) and fan speed (RPM) on an EC/ DC motor is not linear. By way of example, a reduction in the air volume of 30% achieves close to a 50% energy saving in most cases.

The EVO controller and control strategy exploits the fact that most fan coils, at most times, do not need to supply the full design air volume to maintain the desired space condition. Most Fan Coils are sized for the hottest day and with the highest potential occupancy level but how often does this really happen? - Rarely.

The Ability EVO variable speed strategy works by using two proportional loops that influence the fan speed. The first is a simple "proportional only" control loop which defines that the further the room temperature is from set point the higher the fan speed, up to the design maximum. However, while the unit is in control of the space and the room is at or around set point, the fan is allowed to slow to a definable percentage of design, thus saving energy and reducing noise.

The second proportional control loop continually looks at the air temperature leaving the FCU and has the authority to overrule the main strategy and raise the fan speed should it decide. This is generally when the 'air off' temperature is in danger of becoming too cold and dumping air from the grilles. In these circumstances this routine proactively raises the fan speed to elevate the off coil temperature and avoid this undesirable condition. The converse is applied within the heating cycle.

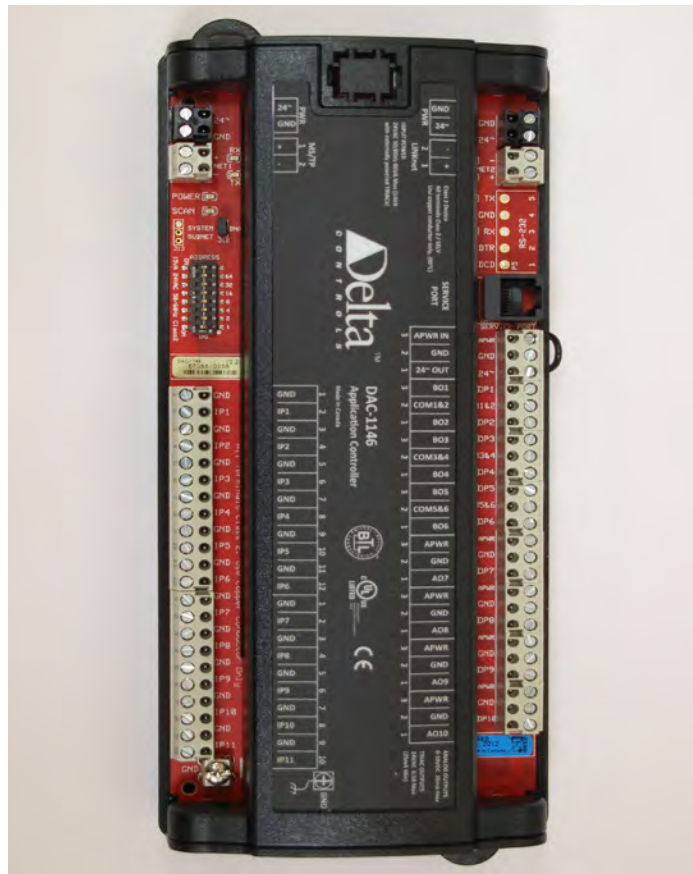

> Harmonic Filter

All Ability EVO fan coil units are supplied with harmonic filters to suppress the level and severity of harmonic distortion to the supply voltage of an electrical system. These filters keep Ability EVO fan coils within the European regulatory requirement.



> Power Factor Correction

Power factor correction of individual fan coil units is not necessary. There will be lots of electrical equipment on every project with various power factors, but the fan coils are likely to be a comparatively small contributor compared to items such as the lighting and computers.

The need for, and the level of, power factor correction has to be evaluated and applied at a building level. This is because some of the contributing loads actually go some way to cancelling each other out depending on whether they are a resistive, an inductive (lagging) or a capacitive (leading) load.

For further information please refer to Engineering Recommendation G5/4-1 October 2005, which considers the connection of non linear loads to electrical supplies.

> Specific Fan Power

The specific fan power (SFP) of the EVO range better the requirement of 2010 building regulations which put a limit on this of 0.6 W/l/s. Under normal circumstances the SFP will be lower than 0.3 W/l/s at design and as low as 0.1 W/l/s at setback.



Product Specification

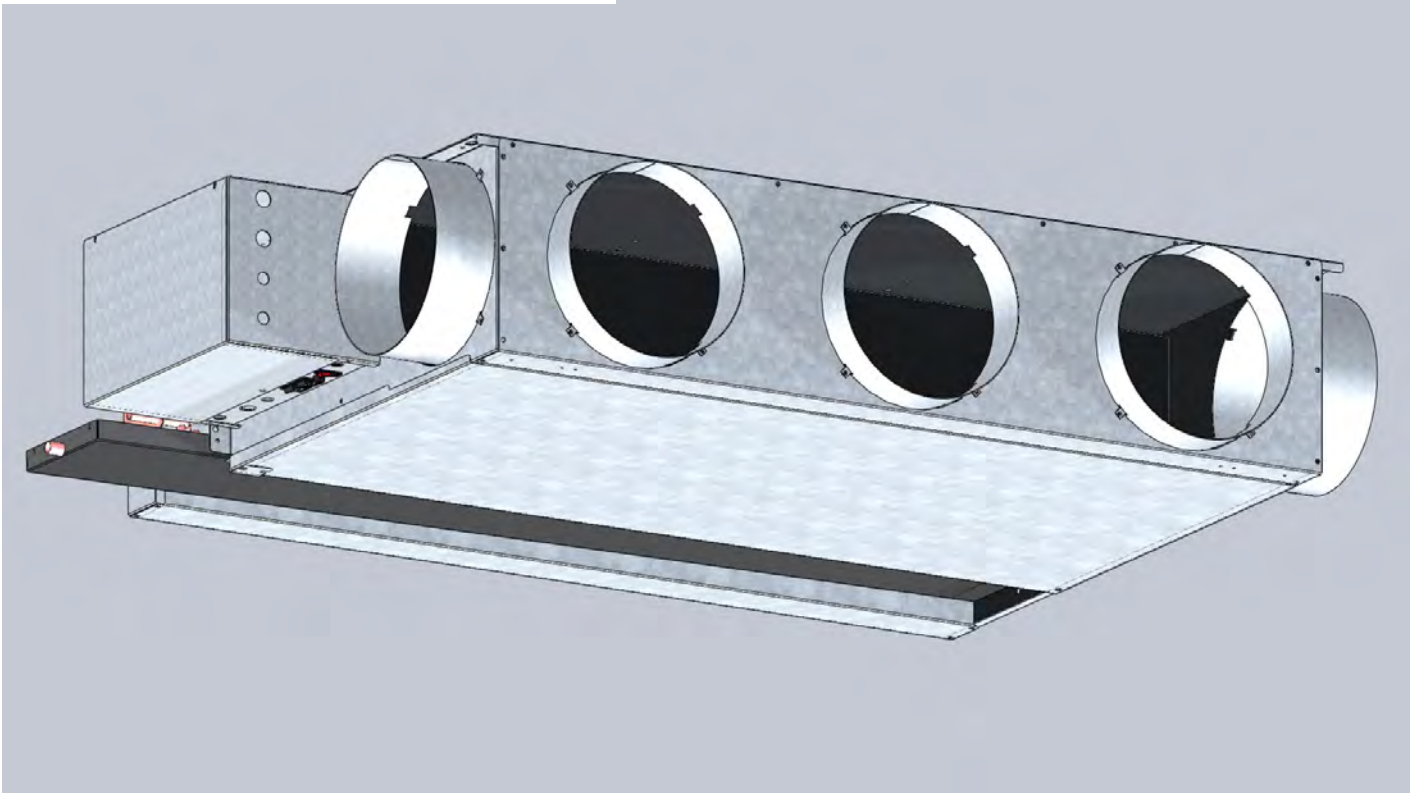

> Casings

Chassis panel work is all 'In House' manufactured from nominally 1.2mm galvanised steel. Where at all possible, flanges are formed inward facing to prevent exposure to bare metal edges. Sufficient forms and folds are incorporated to provide a vibration free, robust structure. The panel work is jointed throughout using 3/16" Polygrip[™] self adjusting and 'air tight' rivets.

> Access

Access is provided through a single panel. This covers the fan/motor sets together with the coil and condensate tray. The fan access hooks in place on a front lip and swings closed. This is then retained by machine screws into captive 'Nutserts'[™]. The coil / condensate tray assembly is retained again by Machine Screws into 'Nutserts'.

> Fans

Fans are of the direct drive, forward curved, double inlet centrifugal type. Both the impellers and impeller housings are of galvanised steel. Fan and motor assemblies are mounted separately to the fan deck assembly using M6 Machine screws into captive 'Nutserts'[™] and can be removed individually for non routine servicing or replacement. Each fan is connected to the fan wiring loom by a Quick connector. Motor and impeller assemblies are statically and dynamically balanced in twin planes.

> Coils

Coils are manufactured from seamless 3/8" copper tube, mechanically expanded onto aluminium fins. Fins are punched with die to form collars to afford maximum heat transfer surface in contact with the tubes. All coils are contra circuited for maximum output and bottom to top, to ensure free venting and draining. Vents and drains are slotted type. Coils are handed for maximum efficiency and the handing is notated against direction of airflow through the unit. Coil terminations are 15mm dia' plain copper at 40mm centres through a copper support plate for rigidity. Every coil is leak tested using dry air under water to 15 bar pressure.

> Condensate Tray

The Condensate Tray covers the entire coil and valve assembly area and has a positive fall to the 15mm drain point. The pan is manufactured from galvanised steel, corners are brazed and the termination is silver soldered into position. Each pan additionally incorporates a pressure normalising external cover. Stainless steel pans are available as an option. All con pans are covered with 3mm closed cell, class 'O' insulation to prevent condensation.

> Insulation

Insulation is used throughout for both thermal and acoustic damping. Insulation is open cell, class 'O', CFC and HFC free expanded foam. Foam complies with CAA airport and London Borough flammability and toxicity requirements. Adhesive has light, ageing and temperature tolerance.

> Spigots

Spigots as standard, are circular 150mm, 200mm, 250mm or rectangular, manufactured from galvanised steel. These are screw fixed to the front of the fan coil unit in the positions indicated. Unused spigot positions are blanked off but remain available for use if layout changes occur.

> Controls Enclosure

All controls are, as standard, fitted to a control back plate which is located on the side of the fan coil. The electrical cover then encloses the controls and gives access from both the side and below. The whole electrical assembly, including switches, is mounted on the side of the fan coil unit alongside the coil terminations and valve assembly.

> Filter

Filters are EU2 or EU3 media secured to a wire metal frame, easily removable for routine maintenance, cleaning or replacement.

> Ancillaries

Inlet plenums, electric heating, stepped outlet plenums, other spigot sizes, side spigots, condensate pumps, fresh air connections and control packages are all available on request.

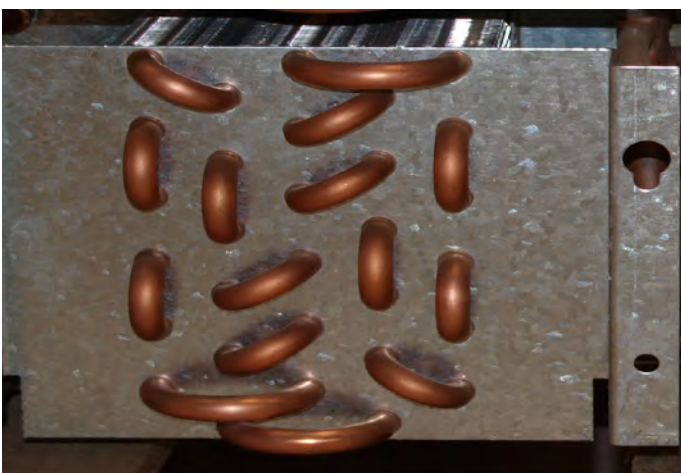

As part of our continuous improvement initiative we have to reserve the right to alter the specifications and or dimensions without notice. Therefore, please check your selections and any recent updates by calling the Ability internal sales office.



EVO 270 / 235

> EVO 270 Introduction

The EVO 270 builds on another Ability horizontal chassis fan coil but with the addition of EC/DC motor technology. Since 2002, the EVO range has established itself as the most efficient and flexible FCU solution always staying ahead of the rigorous demands of our building regulations, let alone the increasing expectations of our energy conscious clients.

At 270mm high, the EVO 270 offers optimum performance for almost any application and being reasonably compact, it is perfect for use in the majority of ceiling voids. The rigid chassis, resiliently mounted fans and ease of access to the major components all add to provide a level of usability that is unsurpassed in the industry.

Accurate performance data is of paramount importance - Ability continually tests its products to ensure all project selections are thorough and correct.

To compliment the latest EC/DC motor technology, all EVO units are fitted with high efficiency heat exchange coils that have been configured to maximise cooling and heating outputs. This is achieved by tuning the design of each coil to the unit in which it is used rather than the often used, 'one size fits all' approach.

> EVO 235 Introduction

The EVO 235 retains all the features of the EVO 270 but within a shallower horizontal chassis format.

Being only 235mm deep, the EVO 235 still offers the highest level of performance while being suitable for the more 'compact' ceiling void. The EVO 235 is available with all the options of its larger counterpart, the EVO 270, and is every bit as capable of supplying the most energy efficient and flexible fan coil solution. Once again, pressure independent control valves, variable speed strategies and a host of remote control functions are possibilities with EVO 235.

All EVO 235 fan coils are fully tested at the factory before they leave for site. Additionally, if our BACnet controls package is fitted, our end of line routine will include uploading the appropriate strategy and running a full strategy diagnostics test.

As with the EVO 270, the pressure independent EC/DC motor option is available.

Performance Based Upon

- Cooling duties are based on an Entering Air of 23 °C dB - 50 % RH.
- Heating duties are based on an Entering Air of 21 °C.
- Leaving Air and pressure drop constraints may reduce outputs.
- Data is with an external static resistance of 30 Pa.
- Minimum water flow rate for performance stated is 0.02 l/s.

270 Hydraulic Pressure Drops

Cooling Coil	Known Flow l/s	Known Press Drop kPa
SIZE 100	0.10	15.5
SIZE 200 & 250	0.15	16.1
SIZE 300	0.20	18.6
SIZE 400	0.25	19.2
SIZE 500 & 550	0.25	15.7
SIZE 600	0.25	16.3

235 Hydraulic Pressure Drops

Cooling Coil	Known Flow l/s	Known Press Drop kPa
SIZE 100	0.10	15.9
SIZE 200 & 250	0.15	17.6
SIZE 300	0.20	19.2
SIZE 400	0.20	13.5
SIZE 500 & 550	0.25	14.9
SIZE 600	0.25	13.5

Heating Coil	Known Flow l/s	Known Press Drop kPa
SIZE 100	0.05	4.3
SIZE 200 & 250	0.05	4.6
SIZE 300	0.05	5.9
SIZE 400	0.05	8.6
SIZE 500 & 550	0.10	6.3
SIZE 600	0.10	7.2

Heating Coil	Known Flow l/s	Known Press Drop kPa
SIZE 100	0.05	4.3
SIZE 200 & 250	0.05	4.6
SIZE 300	0.05	5.9
SIZE 400	0.05	8.6
SIZE 500 & 550	0.10	6.3
SIZE 600	0.10	7.2

$$\text{New Press Drop} = \left(\frac{\text{New Flow}}{\text{Known Flow}} \right)^2 \times \text{Known Press Drop}$$

EVO 270 Schematic

Important Notes

Heating and Cooling Valve connections are reversed on opposite unit handing.

If pressure independent valves are used, the unit width will increase depending on the type selected

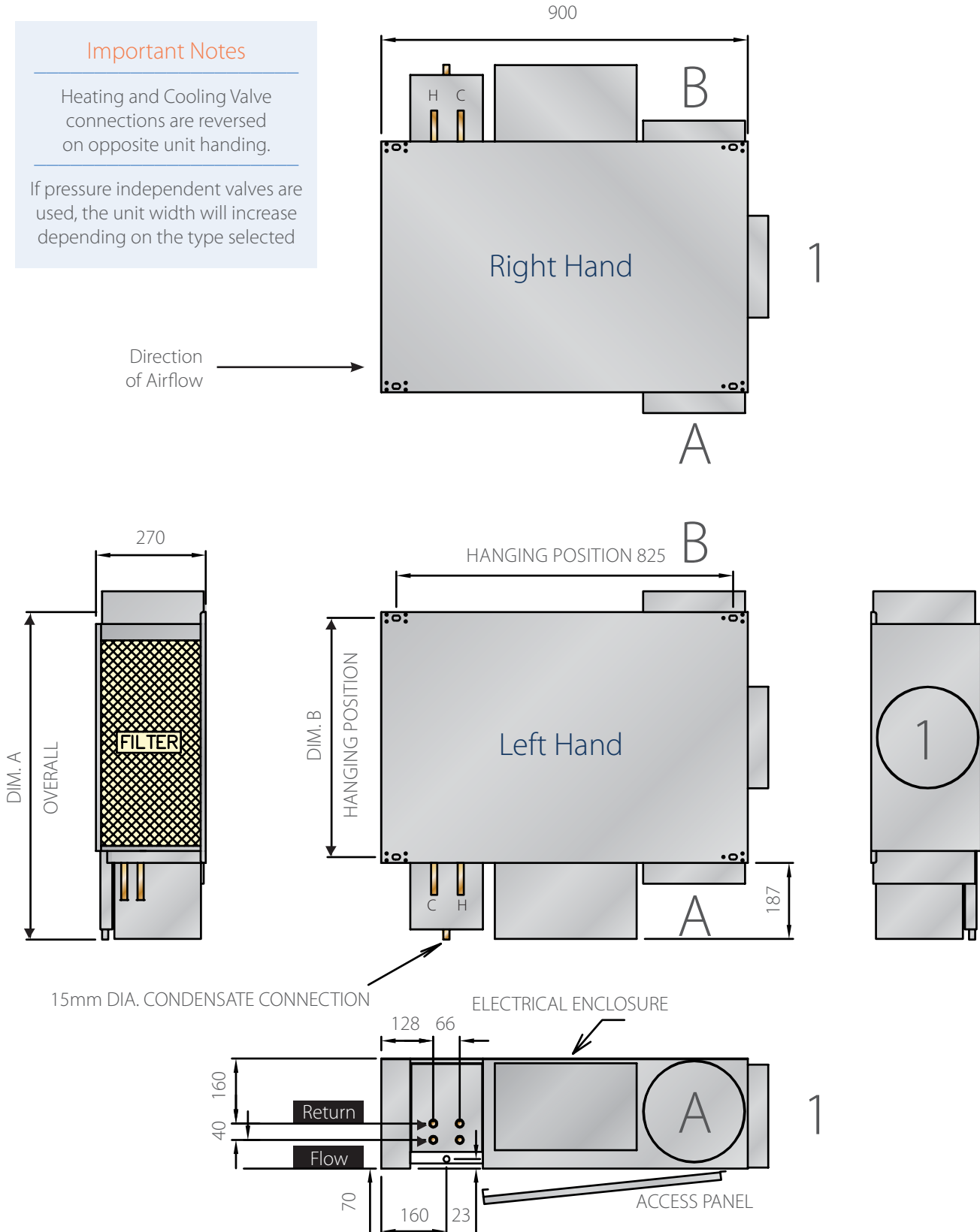

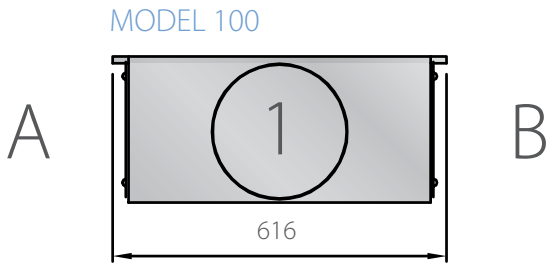

Size	Weight in Kg	Dimension A Overall Unit	Dimension B Hanging Position
100	41	803	587
200	52	1103	887
250	56	1103	887
300	66	1403	1187
400	82	1703	1487
500	93	2003	1787
550	97	2003	1787
600	105	2303	2087

MODEL 200 and 250

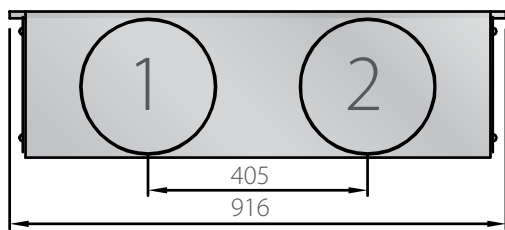

MODEL 300

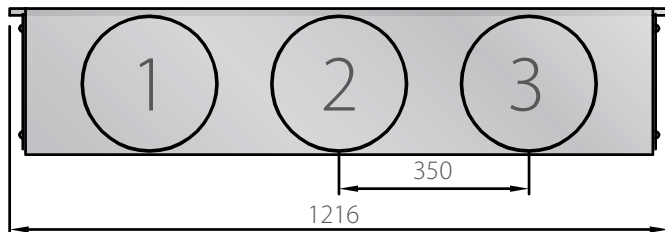

MODEL 400

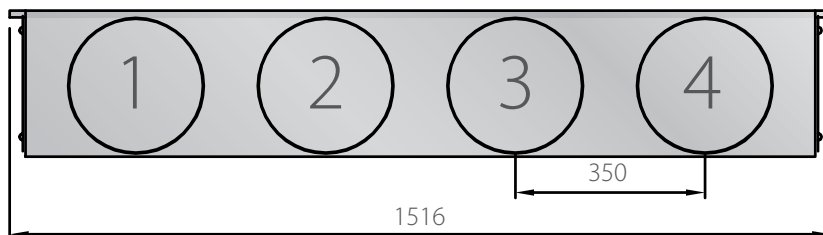

MODEL 500 and 550

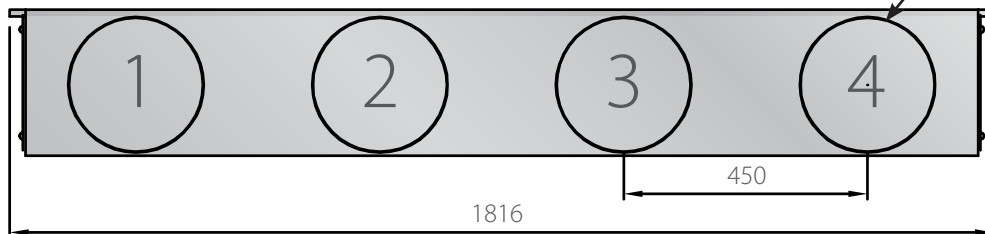

MODEL 600

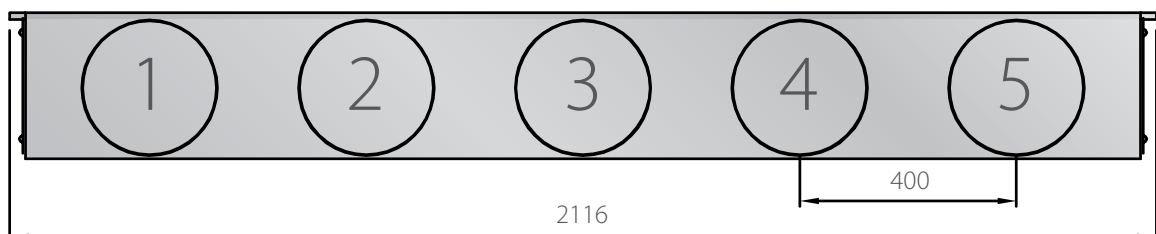

Important Note

Standard spigot connection sizes are 200mm and 250mm diameter circular or rectangular. Other sizes available on request

Spigot numbering is as shown irrespective of unit handing

EVO 235 Schematic

Important Notes

Heating and Cooling Valve connections are reversed on opposite unit handing.

If pressure independent valves are used, the unit width will increase depending on the type selected

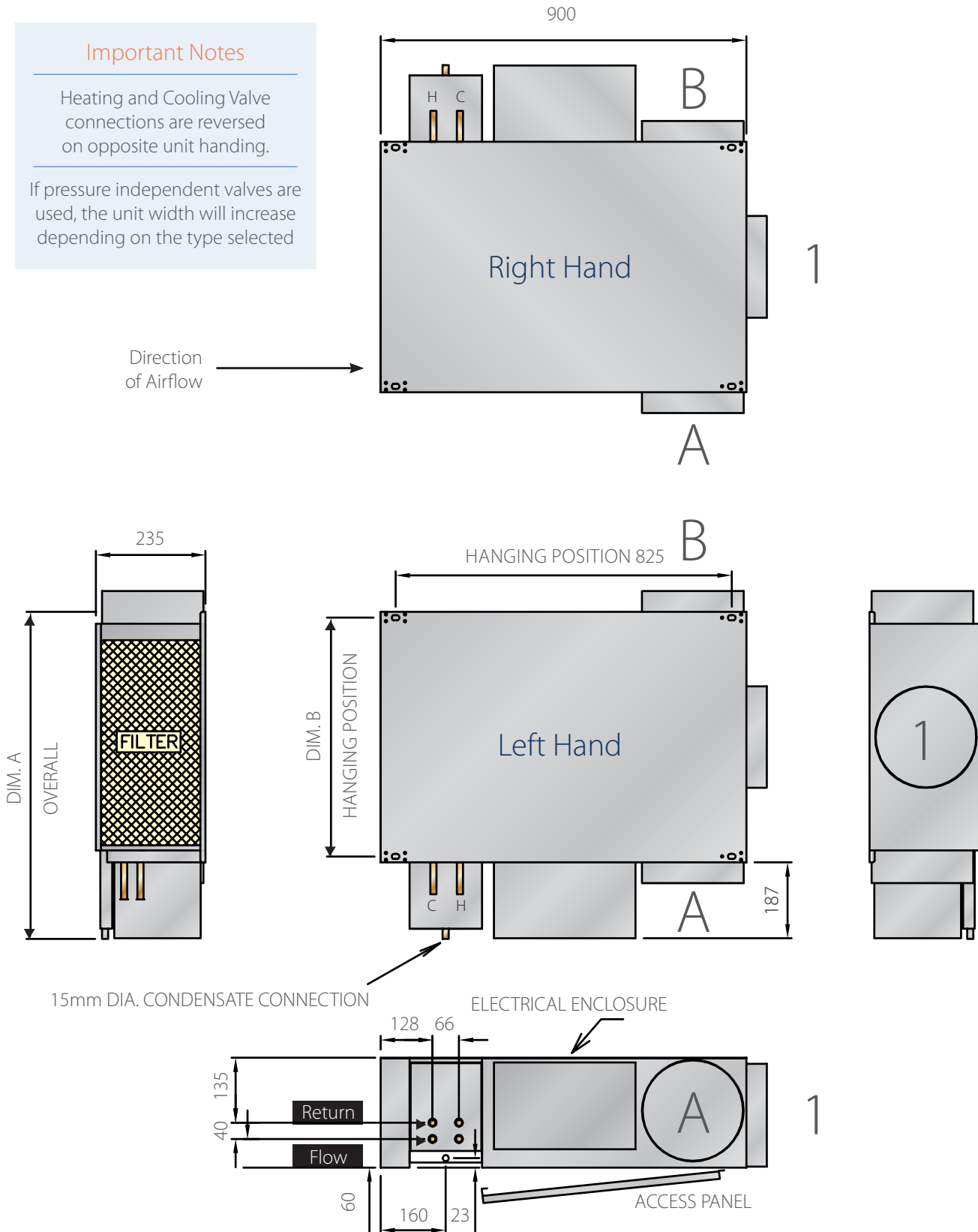

A

MODEL 100

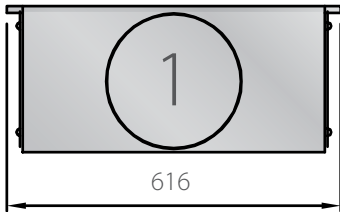

B

Size	Weight in Kg	Dimension A Overall Unit	Dimension B Hanging Position
100	37	803	587
200	48	1103	887
250	52	1103	887
300	60	1403	1187
400	78	1703	1487
500	86	2003	1787
550	92	2003	1787
600	97	2303	2087

MODEL 200 and 250

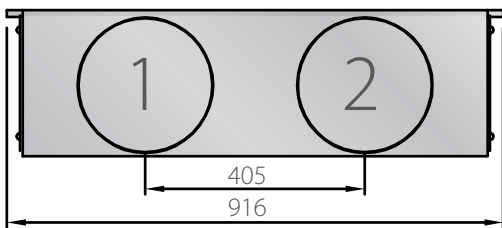

MODEL 300

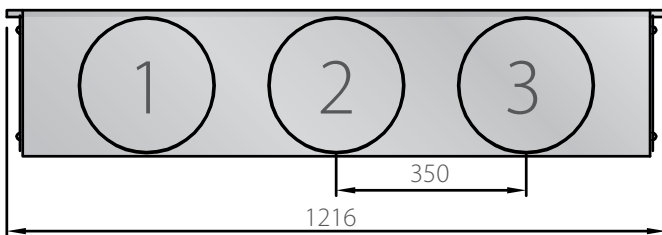

MODEL 400

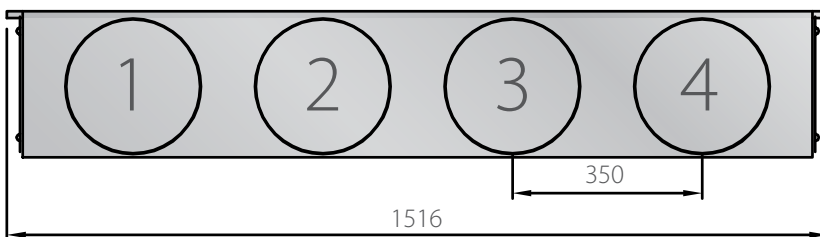

MODEL 500 and 550

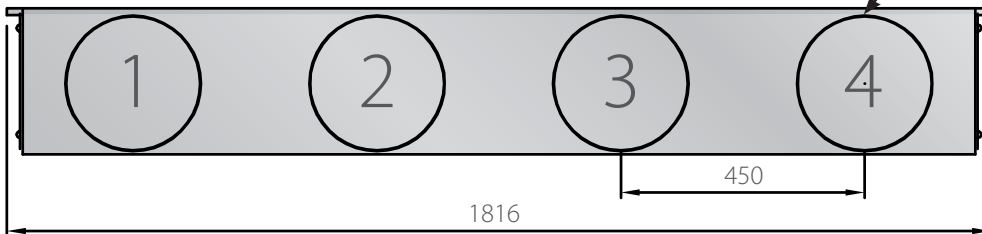

MODEL 600

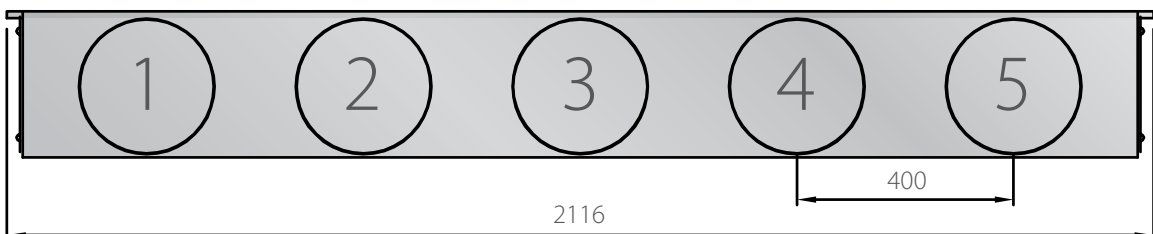

Important Note

Standard spigot connection sizes are 150mm and 200mm diameter circular or rectangular. Other sizes available on request

Spigot numbering is as shown irrespective of unit handing

Acoustic Guide



> NR Guide Calculations

The NR Guide figures quoted in our Fan Coil Selections are calculated from the logarithmic addition of the Sound Power Levels for Inlet/Cased Radiated and Discharge, measured at the Sound Research Laboratories with adjustments made for room effect.

Our room effect adjustments are based upon the following criteria:

- A room with a reverberation time of 0.7 seconds or less.
- A room that is occupied and in normal use.
- The Fan Coil installation density is based upon 110W/m² Sensible cooling.
- A room which is 2.6m high from floor level to suspended ceiling.
- We have not allowed for any contribution from background noise sources, including other plant / equipment. This requires the background noise levels to be at least 10 dB lower than the specified room NR level.
- The Fan Coils are hung in accordance with our Installation Instructions and the latest CIBSE guidelines.
- Suspended ceilings have a Noise Reduction Coefficient of 0.6 and a Noise Reduction Performance $D_{ncw} = 35\text{dB}$ or better.

Based upon these conditions, the following adjustments are made across the SPL spectrum.

	63	125	250	500	1K	2K	4K	8K
Ceiling tile loss	-6	-4	-7	-10	-12	-12	-13	-8
Room Volume/Reverb	-2	-2	-2	-2	-2	-2	-2	-2
Distance to Listener	-14	-14	-14	-14	-14	-14	-14	-14
Directivity Factor	+9	+9	+9	+9	+9	+9	+9	+9

The adjusted Sound Pressure Levels across the frequency range are then compared to standard NR Curves to give the resultant NR Level.

Important Note: These NR Levels can be guides only as we will not have room data for all areas of your project upon which to base project specific calculations. We have however, conducted numerous tests within our own office and on completed sites, so providing your project is similar to our descriptions above, the NR levels will be equal to (or very similar to) our calculated figure. If your site differs from the descriptions we have provided, it is in your best interests to either ask us for our view on the differences or seek independent advice.

> NR Adjustments

If any of the following conditions apply to your project then the NR levels quoted may need to be adjusted as shown. If more than one of the following conditions apply, or you are concerned in any way, then you should consult with the Ability Technical Team.

Installed Condition	Potential Acoustic Additions
Contract quality carpet, standard fibrous tile ceiling system, glass area approximately 50% of wall surface. Units installed using solid ductwork, insulated acoustic flex, insulated plenum and linear grille.	0
Solid floors - wood	+1
Tiled floor, marble or similar	+2
Full height glass	+2
Perforated steel tile ceiling system with 16mm acoustic pads installed into all tiles.	0
Perforated steel tile ceiling system with acoustic pads but where the return air path is through punched holes or slots in the ceiling tile system. The acoustic impact will vary so please advise.	Please provide details
Perforated steel tile ceiling system with no acoustic padding in some or all tiles / infills.	Potentially +6
Discharge grille plenums with no internal insulation material applied and or perforated steel VCD's	+1 / +2
Short rectangular ducts straight to discharge grille. The acoustic impact will depend greatly on the length of the duct and any insulation.	Please ask
Any other condition of concern. These might be units in very close proximity to each other, very small cellular offices or a particularly high thermal requirement W/m ² etc.	Please ask

> Recommendations

- Acoustic Flexible Ductwork is highly recommended on all installations where possible. Even a short length of 500mm will greatly assist in keeping the sound pressure levels at or below that required.
- Duct velocities between the FCU and the grilles/diffusers should be equal to or lower than 2.5 m/s to reduce the potential of regenerated noise from the balancing damper (if installed), ductwork and/or the diffuser plenum.
- Care should be taken so as to avoid positioning ceiling return air path immediately beneath the FCU air inlet to avoid a direct line for the inlet sound to penetrate into the occupied space and cause excessive noise.

Installation Guide

Your new Ability fan coils will operate for many years affording a comfortable, controlled working environment. This sheet provides useful installation guidelines, a trouble shooting table and a list of routine maintenance procedures.

If your fan coils behave unexpectedly then first refer to the troubleshooting suggestions and apply any remedies that appear appropriate. If this does not solve the problem then please contact Ability so that we can investigate further.

> Ducting

Do not use a greater length of duct than is required. Using 2 metres of duct where 1.5 metres would have been enough means the internal spiral will not have been stretched sufficiently. This leads to internal air turbulence, extra resistance and noise.

To avoid this risk flexible ductwork must be installed carefully.

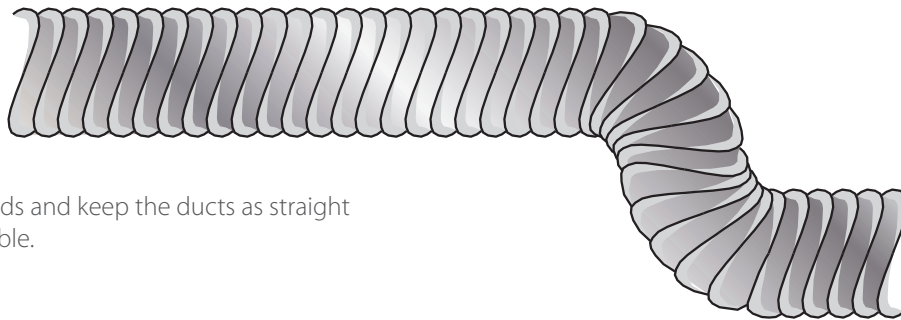

- Try to avoid tight bends and keep the ducts as straight as is reasonably possible.
- Avoid squeezing ducts under or around obstructions.

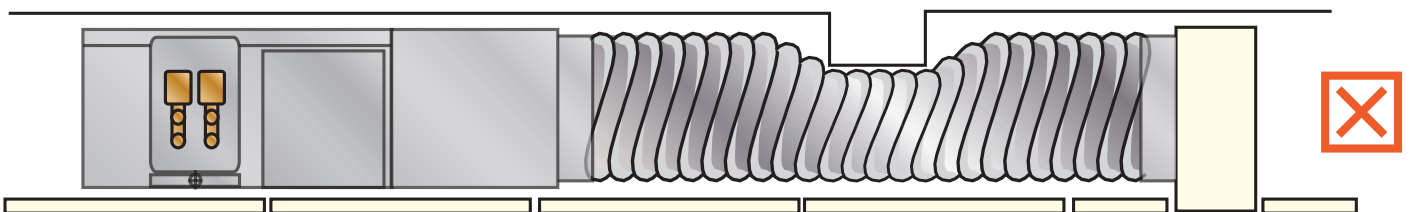

All fan coils are selected to perform against a specific duct resistance. Inadvertently increasing this resistance will have major implications to the performance of the unit and the building as a whole. The air volumes will fall, the kW outputs will reduce, the fan speed will increase, the unit will become noisier and the balance between ducts may be upset.

If an imbalance persists between two ducts from the same fan coil inspect the duct runs from the fan coil to the plenum / grille. Rearranging or straightening a duct can add another 5 to 15% to the air volume.

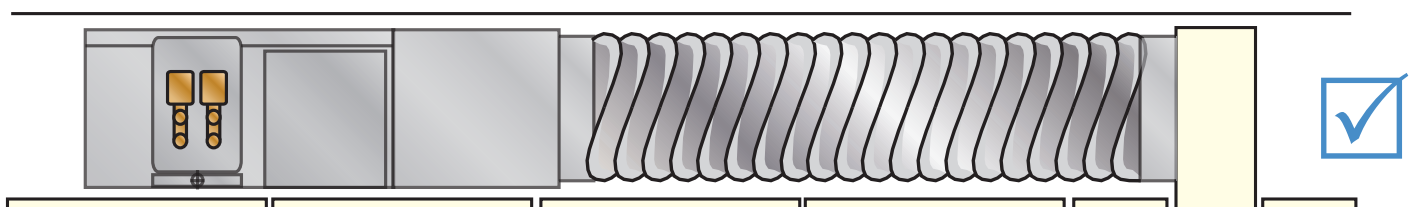

> Access

All fan coils require regular maintenance. Filters, fans and coils need periodic cleaning to maintain their correct level of performance. It is therefore very important to leave adequate space around the access areas to make maintenance as easy as it can be.

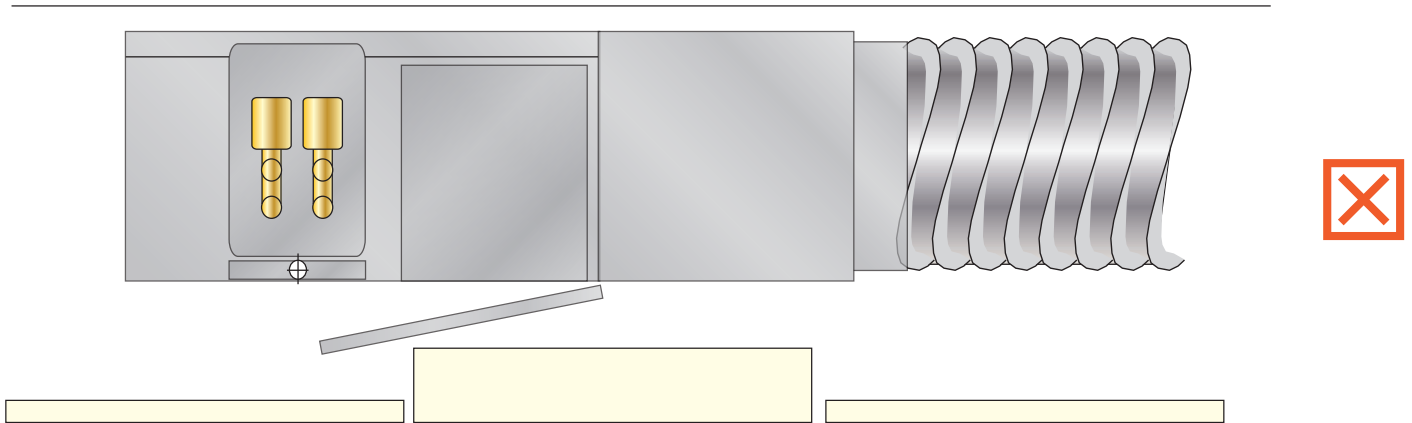

Areas that will require periodic inspection are :-

- Filters • Valve assemblies • Electric box and Controls • Fans • Coil and Condensate tray.

Keep fan coil access areas away from light fittings that cannot be removed from the ceiling grid and other immovable service ducts, pipes and conduits. Try and avoid positioning units so they span over a partition wall.

> Condensate Connection

The condensate connection on any fan coil is delicate and should be treated with care.

Connection between the condensate tail and the main drainage system should be made using a "removeable" fitting. If removal of the condensate tray is required for cleaning or similar then this connection will need to be broken and then remade.

To assist condensate drainage:-

- 'U' bend traps between the unit and the drainage system should be installed if at all possible.
- Condensate pipe work should incorporate a gravity fall in line with the current regulations.
- Condensate pipe work should be well supported and pipe work runs must not sag.
- Condensate drainage pipe work may need insulating depending on the drain pipe material and/or the chilled water temperatures.

NB: If condensate does not drain adequately from the fan coil it is most likely the filters have become too dirty.

> Fan Coil Level

A fan coil installed sloping the wrong way will leak condensate, spoil the ceiling tile system and may damage the client's office equipment below the ceiling.

Fan coil units incorporate an open condensate collection pan. To ensure the condensate collected in this pan flows away efficiently and does not overflow, the fan coil should be at least level. Given the opportunity, the fan coil should be sloped slightly towards the condensate drain end which will assist the flow. The fan coil must never be installed sloping away from the drainage / valve end.

NB: If condensate leaks from the fan coil soon after installation it is most likely the filters have become laden with dust and debris thrown up during the installation process.

Installation Guide

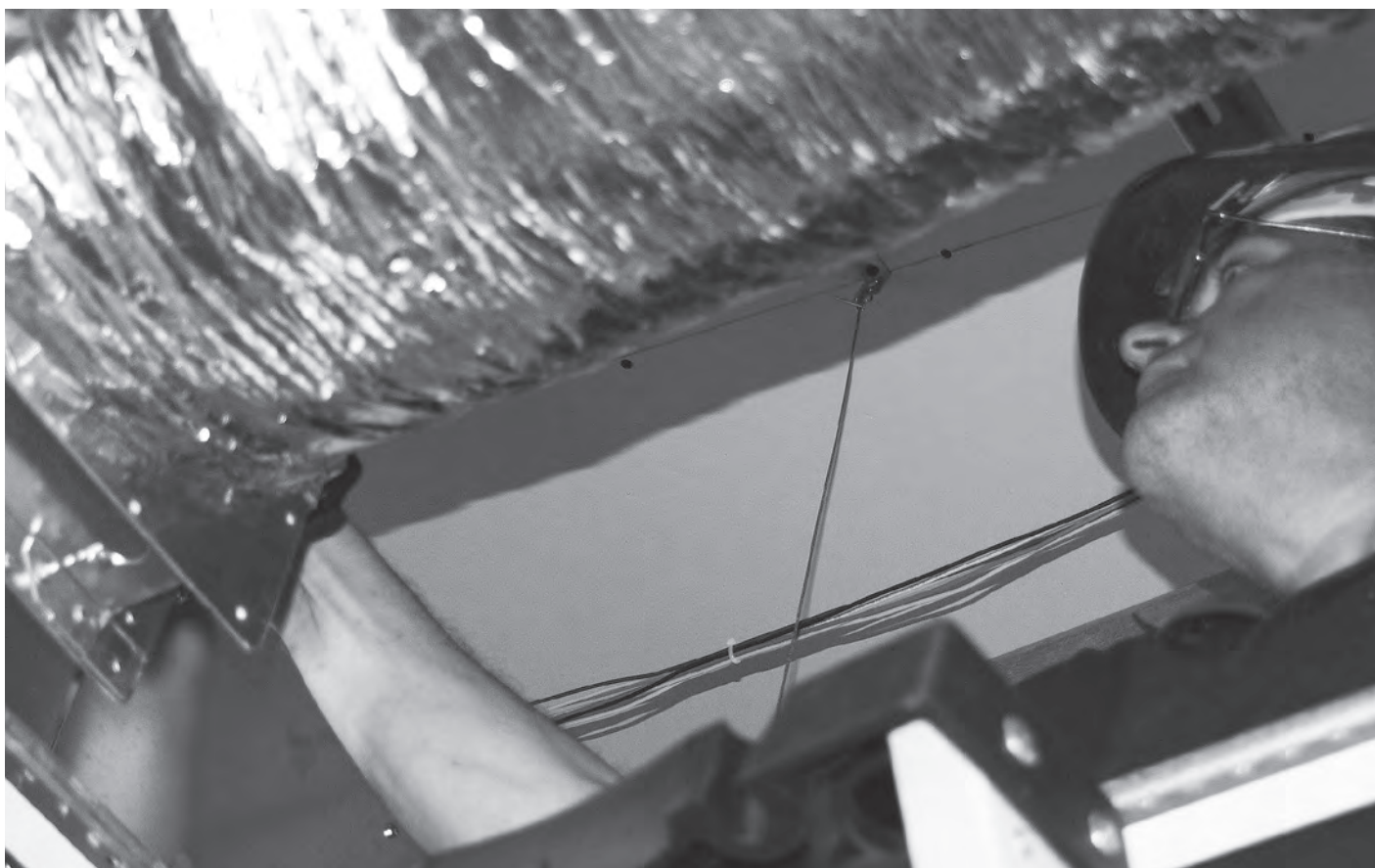

> Fan Coil Controls

Many fan coil control packages, when switched on, will go through a set up or diagnostic routine. This will last at most about 15 minutes and may make the units appear “Out of Control” for this period. Remember, the diagnostics will run each and every time you turn the power off and on so it is best to let the unit controls settle before you draw any conclusions.

> Fan Coil Control Sensor Position

- If the fan coils have room sensors, do not mount them in direct sunlight, in a draft or near a door.
- If you relocate a unit mounted sensor ensure the new position is away from sources of heat and cold such as light fittings and pipe work.
- If after a fit out, a single fan coil is now serving two rooms, the sensor may need relocation or the whole control package may need reconfiguring.
- Some control packages incorporate a small time delay before they react to a new demand from their sensors. This is to prevent controls “hunting”.
- Sometimes the temperature above the false ceiling can be a couple of degrees above the room temperature below. This can lead to a “cooler than expected” room environment. If this happens you can either offset the controls to compensate or you may have to consider relocation of the sensors.

Servicing and Routine Maintenance	
Before handover to client	Clean Filters Ensure all valve commissioning pegs and caps have been removed Recheck design fan speed and temperature settings
Every 3 Months	Clean filters
Every 6 Months	Clean filters Brush or vacuum coil surface
Every 12 Months	Clean or replace filters Brush or vacuum coil surface Wipe out condensate tray and chemically clean if required Vacuum fan and motor sets if required. Visually inspect for any failures or failing components

Problems and Possible Causes	
Air Volumes are lower than expected or the noise level is higher than expected	Signal voltages above 7.5V will never be selected by Ability. If you have an installation defect or measurement error, turning the fan speed ever higher will not solve the problem but will, generate noise. Is the filter dirty If VCD's are fitted, have they been left closed. Are the flexible ducts installed correctly. There should be no tight bends, no restrictions and no excess material in the length
Condensate does not drain or the unit leaks	Is the air filter dirty - Dirty filters impede condensate flow Is the fan coil installed out of level Have the commissioning valve caps or pegs been removed Has the set point temperature been reset correctly after commissioning Is the sensor being "fooled" by an external temperature influence Have the controls not yet finished their start up diagnostics routine
Unit becomes noisier over time	Is the filter dirty

Controls Packages



Ability Projects can provide specialist control guidance from conception and specification through to delivery.

Also, as a Delta Controls partner, Ability draws on a wealth of experience from Delta's own development teams ultimately providing the most robust hardware and software controls solutions.

A fully tailored package might include bespoke strategies and coding, project specific trend logs or alarms and possibly even customised touch screen graphics.

Of course, off the shelf packages are always available. However, even these Ability solutions are far more advanced than most including amongst many options, occupancy setbacks, variable fan speeds, time scheduling and remote access.

> DELTA-DAC1146(E)

The DELTA-DAC1146(E) is a fully programmable, Native BACnet™, advanced application controller that can communicate on an RS-485 or Ethernet LAN.

The DELTA-DAC1146(E) can handle a wide-range of applications .

> Control Valves

Ability Projects can supply Fan Coils with complete valve sets fitted at time of manufacture. These include many options: 2 port, 4 port, and the latest generation PICC valves, for example the Marflow Xterminator pictured opposite.

The Marflow option provides one of the most compact sets available which includes PICC valve, a flushing bypass, venturi nozzle, drain and return isolation valve. All of this is located above the Fan Coil drip tray.

> BACstat – Intelligent Wall Mounted Room Sensor

The DNS-24L is an intelligent room sensor with a custom LCD display and 4 push buttons for user control. Without consuming any additional inputs, certain BACstat units give access to CO2, Humidity and PIR Sensors.

The DNS-24L is useful in applications that require one or more low cost, programmable sensors with LCD display and push-button control.



> 7" Touch Screen – enteliTOUCH



The enteliTOUCH is a seven inch, wide-screen, LCD touch sensitive display unit used for interfacing with your EVO units and any BACnet building automation system.

The enteliTOUCH uses BACnet over Ethernet to communicate with all the controllers on the local area network using real time information and a graphical, intuitive interface.

Fully configurable, this elegant screen can be used from simple activities such as set point adjustment through to performing as a mini BMS (Building Management System). The full colour screen is designed to act as a full BMS supervisor supporting routines such as scheduling and trend logging.

While the possibilities for this unit are endless, below are three examples of its many uses.

- Used in a hotel bedroom, the touch screen acts as a room controller which is able to control lights, blinds and of course the fan coil, via the correct O/I.

Further integration can result in adverts being displayed on the screen. These adverts can be sponsored to help offset the cost of purchase and can run alongside screens displaying useful information about the hotels other facilities and events. An integrated PIR means that the screens are only active when somebody is close by which saves further on the running cost.

The web server functions allow maintenance staff to access each device individually and assess any complaints instantly, further increasing client and occupant satisfaction.

- The Manager of a retail outlet wants to be able to globally adjust the set point and override the scheduling of the fan coils in his store. The touch screen is set up to allow this simply and without any great technical understanding being necessary.

Again the web server function coupled to an internet connection allows remote access from facilities management team to access and collect information.

- The staff in a hotel restaurant with private dining areas would like to be able to individually adjust the temperature in each of these dining suites.

To facilitate this, the touch screen can be located anywhere convenient and these adjustments can be made using a full colour plan of the restaurant and its services. No longer do the Facilities Management team need to be called as the restaurant staff can deal immediately with most eventualities themselves.

Other Products & Services from Ability

> A full range of fan coil units is available from Ability Projects:-

- Matrix Fan Coil package. Ability's complete air conditioning solution including self setting air volumes and duct balance, self setting design water flow rates through remotely controlled PICC valves all overlaid with intelligent, intuitive control strategies.
- Vertical Fan Coil. A slim, low height unit in both chassis and cased formats. Cased units are available for high level, low level and bespoke installation situations.
- Underfloor Fan Coil. Including all the attributes of the Ability horizontal products, these units are a simple reconfiguration allowing the same successful features to be used in any underfloor application.
- Trading Desk Fan Coil Cooling. Offered in association with DAS Business Furniture or Saffron Walden, the ultimate trading desk solution with integral cooling to offset the heat generated by PCs and screens. Used by many leading financial institutions!

> Fan Coil Refurbishment and Technology upgrades.

Ability can breathe life into any older fan coil unit.

The primary role of the Ability Service Department is to support customers who have already bought Ability products. However, through many very successful projects, Ability have now acquired an unsurpassed reputation for fan coil refurbishment and technology upgrading.

- Swap out AC fan motors and replace them with EC/DC fan types saving half the electrical input and extending FCU life expectancy considerably.
- Additionally, apply Variable Air Volume (VAV) strategies to your new fan motors and save another 30% on electrical consumption.
- Swap out any old controllers for new BACnet devices opening up new strategy opportunities including VAV, low occupancy setbacks, 'web based' remote monitoring and adjustment.

Almost every feature you could specify on a new fan coil, Ability can retrospectively apply to any existing model, from any manufacturer. This can provide all the energy saving features and all the flexibility without the level of disruption that a full FCU replacement would promote.

St Olaf House, London. Refurbishment of 70 fan coils from the eighties. A full survey was conducted and a report submitted. All filters replaced, a number of controllers were replaced and the units themselves had a number of sheet metal parts either repaired or remade.

Palestra Building. Upgrading 750 Ability units from AC to EC/DC motor technology. Albeit a relatively new project, the client decided that the energy savings offered by EC/DC motor technology were too great to be ignored. The AC airflows were measured and recorded so that when the fans and motors were swapped, the units were returned to their 'as commissioned' state.

Surrey Project. Replacing 65 vertical fan coils. These vertical cased units needed updating but it was decided the original casings had to remain. Ability manufactured and installed a specially adapted vertical product, customised for this job alone to fit the existing housings.

Turnford Place, Cheshunt. Full refurbishment of 204 ceiling mounted units. Ability replaced the valves, the terminal controllers and converted the units from AC to EC/DC fan motors.

Watling St, London. Full refurbishment of 30 units. The original AC fan decks were replaced with new style 'internal rotor motor' products in conjunction with new valves, new controllers and remanufactured condensate trays.



Palestra



Birmingham Hospital

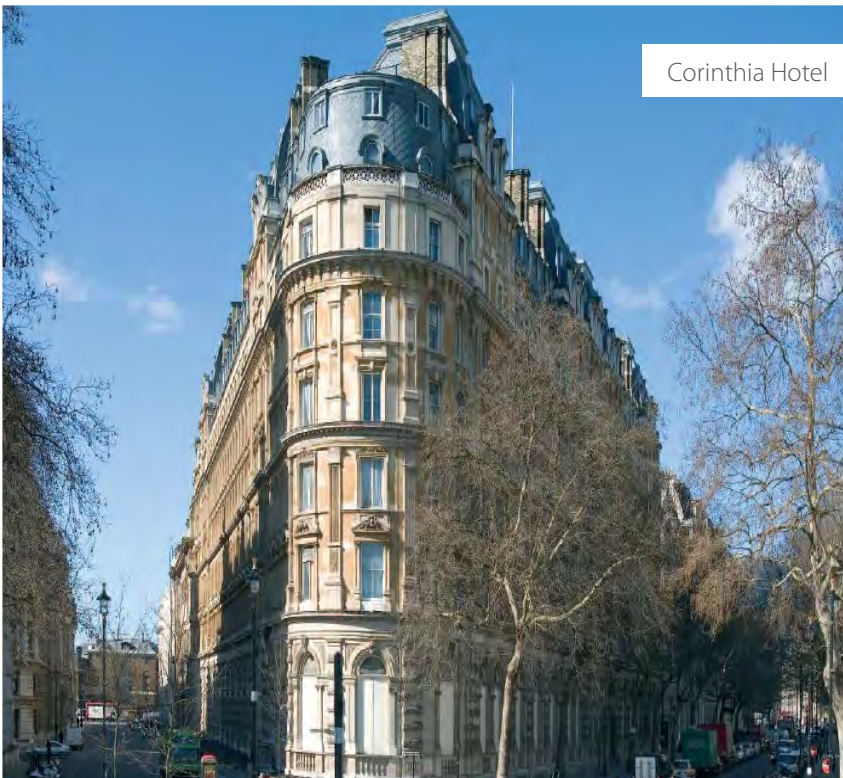

Corinthia Hotel



The Shangri-La Hotel
At The Shard

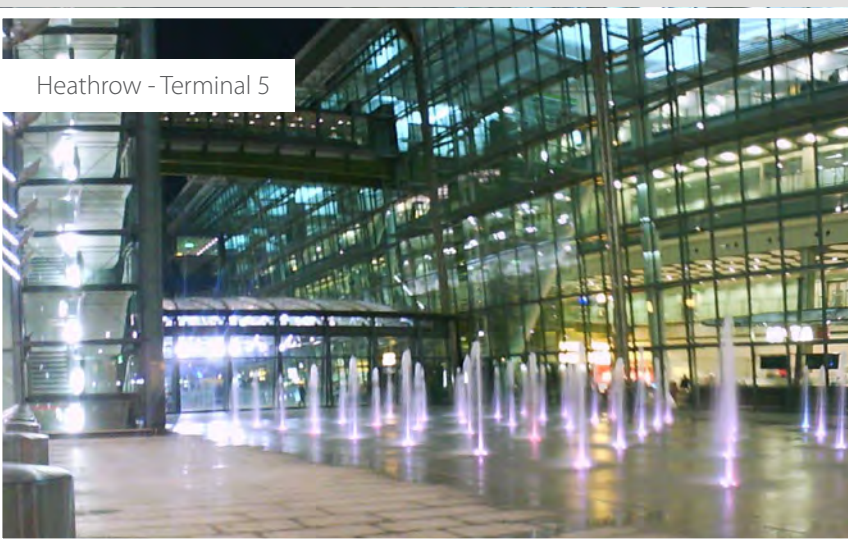

Heathrow - Terminal 5

To see our full portfolio, please visit - www.abilityprojects.com/projects



The Fulcrum, 2-3 Vantage Way,
Poole, Dorset, United Kingdom
BH12 4NU

T - 01202 305800
F - 01202 734470

sales@abilityprojects.com

