

50MM FAUX LEATHER VENETIAN BLIND INSTALLATION INSTRUCTIONS

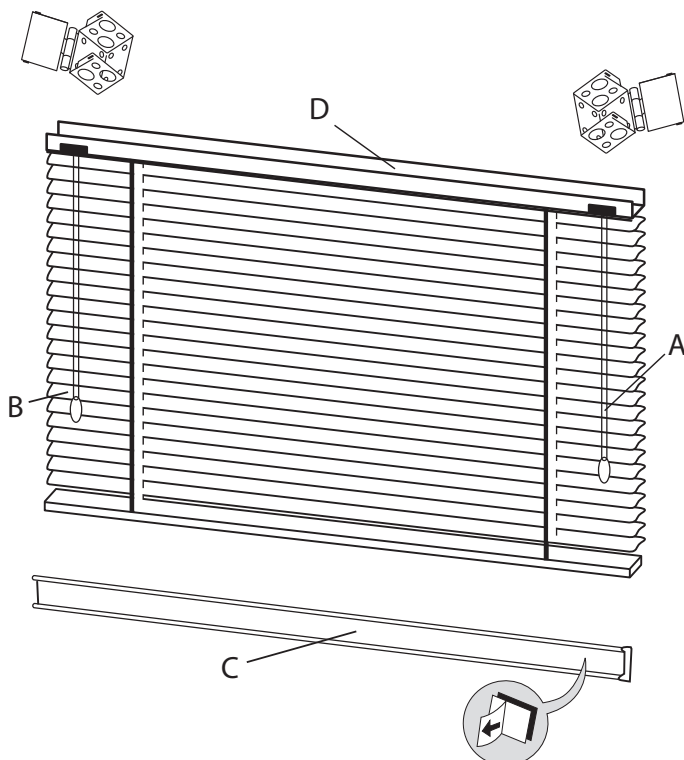
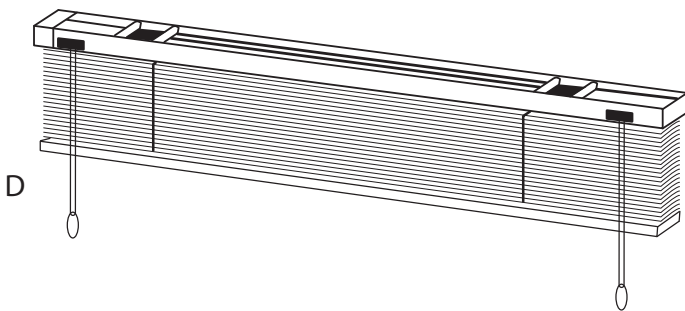
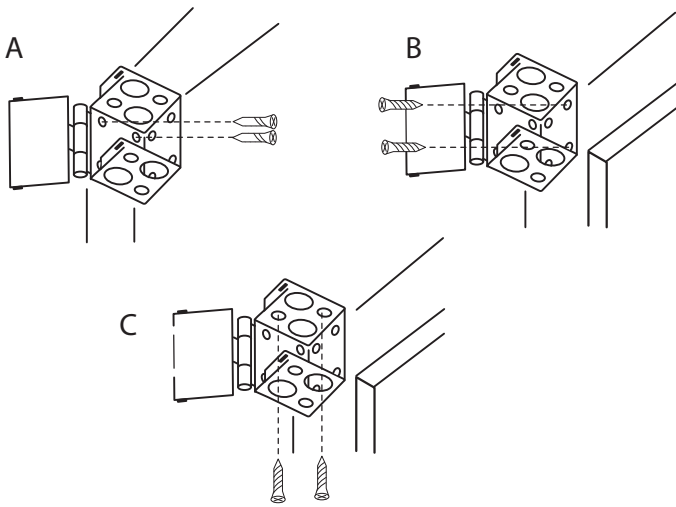

ACCESSORIES ENCLOSED

- ❶ 2 mounting brackets placed at both ends of headrail.
- ❷ 1 attachable valance.
- ❸ 8 screws packed in poly bag.
- ❹ Intermediate brackets if required (only supplied with larger width blinds).

HOW TO INSTALL

- ❶ Select the method of mounting that best suits your purpose (see illustrations A, B & C).
 - A Inside, mounting to the inside or between the sides of window frame.
 - B Outside, mounting to the face or outside of the window frame.
 - C Ceiling, mounting to an overhead surface such as the top inside of window frame or the ceiling.
- ❷ Measure where you want the blind to hang, make sure that the blind is centred and level. When it is positioned properly, make a small pencil mark at each side of the blind to refer to when you attach the mounting bracket.
- ❸ Hold one bracket (the large hole faces the floor) at desired height and width you have chosen and mark the screw holes with a pencil. Then insert and tighten screw through bracket slot.
- ❹ After the first bracket is mounted, carefully position and attach the second bracket. Double check to be sure that it level with the first bracket and that the brackets are the proper distance apart.
- ❺ Pick up the blind and slide the headrail into the brackets. Make sure that the blind operating cords face toward you. Close the front cap on each bracket (see illustration D).

TO OPERATE BLINDS

Lowering:

Hold cord A at eye level and move to left pulling down gently until cord lock releases. Allow cord to slip through fingers until blind reaches desired level. Move pullcord to the right and release, blind will lock automatically.

Raising:

Pull cord A downward until blind reaches desired height, release cord, the blind locks automatically.

Tilting:

Pull operating cord B on left side of Blind to attain desired slat positions.

Important:

Always tilt blind horizontally before raising or lowering, this increases the life of the blind.

ATTACH VALANCE C

After your blind has been installed, attach the matching valance by velcro to headrail D.