

INNOVATION BUILT ON EXPERIENCE



maibec[®] CLADDING

factory-stained solid wood



METAL ROOFING
CONSTRUCTION MEMBRANES
THERMAL INSULATION
GEOSYNTHETIC ENGINEERING
ACOUSTIC INSULATION
VIBRATION ISOLATION
TIMBER CLADDING



*A. Proctor Group Head office
(The Haugh Blairgowrie)*

The A. Proctor Group has partnered with maibec® specialist manufacturer of quality factory stained solid wood for external cladding.

maibec® provides the rich beauty of natural wood without any fuss and also maintenance free, at a price that is sure to please.

maibec® has been a leading manufacturer for over 20 years, with its exclusive 100% control over all steps of production.

The result, wood cladding that has a warranty for 50 years against wood decay, and 18 years on stain extendable for another 15 years.

THE NATURAL BEAUTY OF CANADIAN SPRUCE



maibec®'s factory-stained solid wood cladding is the real thing; what imitation products strive to duplicate.

Wood is the only renewable building material, durable, distinctive and supported by comprehensive warranties.

Wood has visual impact, wood looks good with everything.

Sensitive to the expectations of today's consumer, maibec® cladding is backed by solid warranties to protect one's investment.

Guided by a profound respect for the environment, maibec® arbors proudly its FSC certification as a cladding mill.

DISTINCTIVE

[wood provides character through its contrasting textures and tones. Its natural beauty enhances any project like no other cladding]

SUSTAINABLE

[wood is a renewable resource: the only true environmental choice in exterior claddings]

DURABLE

[wood has time tested durability, having withstood the harshest climates]



PEACE OF MIND

with maibec® cladding

The longevity and beauty of maibec®'s cladding is directly linked to its elaborate quality control system. Combined with two decades of manufacturing experience, it is no wonder that maibec® is the trusted name in wood cladding:

1. maibec® produces its very own cladding wood grade, which is independently dried and profiled in-house.
2. As the profiled wood is prepared for staining, it is closely monitored to ensure optimal dryness.
3. The staining process is performed in a factory-controlled environment, where all sides of the boards are flooded with Cabot® stain. Pressure rollers spread the coating evenly, followed by high speed brushes that drive the stain into the wood for maximum protection. Back-priming enhances the structural stability of the wood while increasing the cladding durability.
4. The wood is fed into the oven dryers, to ensure optimal adherence of the stain. The second coat is immediately applied, using the same process, eliminating any chance of contamination.
5. Coloration experts are on hand for tone validation.
6. Any excess stain is either re-used or solidified for ecologically friendly disposal.

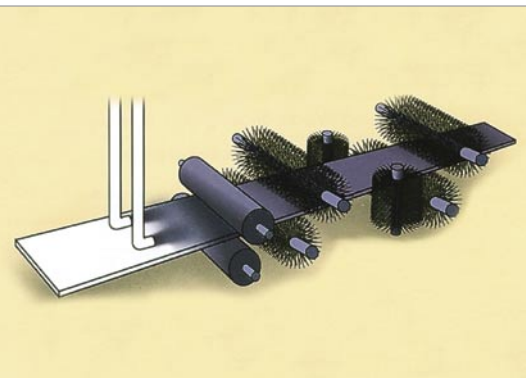

maibec® cladding supported by comprehensive warranties

50-years: Limited warranty against wood decay.

18-years: Warranty on Cabot® Factory-finish stains; cracking peeling or blistering of the finish.

Add 15-years: This warranty can also be extended for 15 years by refinishing with 2 coats of solid colour Cabot® prior to the end of the original warranty.

BE CREATIVE WITH COLOUR ANY COLOUR!

[**maibec**[®] cladding factory-stained with Cabot[®] stain reproduces any colour imaginable for the unique style you're looking for]



CREATE A LASTING IMPRESSION



Bevel

V-joint

Channel

Cove

Board and Batten

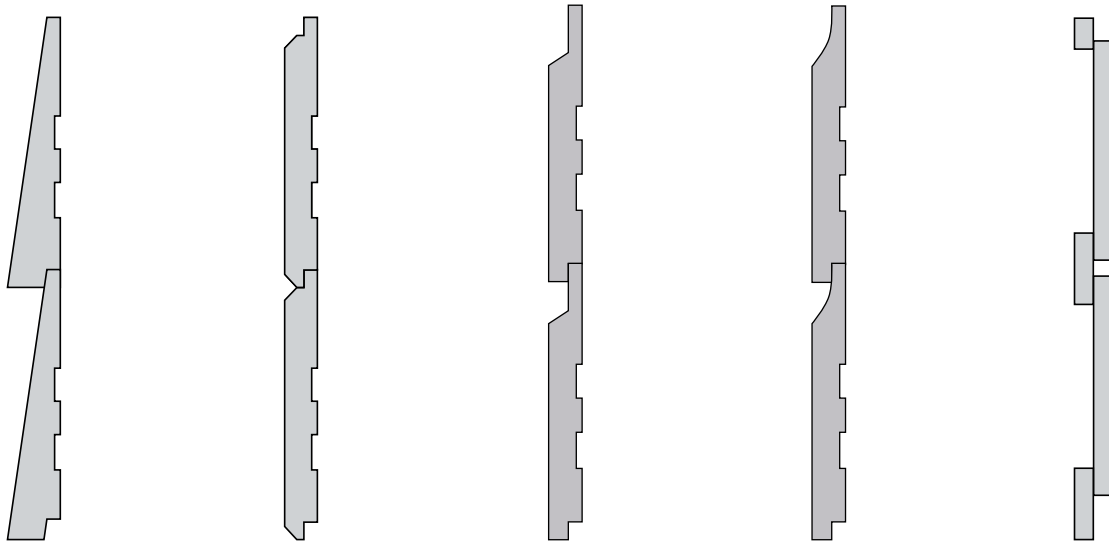

Available dimensions:

The chart below indicates the standard dimensions and profiles available.

Bevel	V-joint	Channel	Cove	Board and Batten
24mm x 90mm (77mm surface coverage)	24mm x 90mm (77mm surface coverage)	19mm x 142mm (127mm surface coverage)	19mm x 142mm (127mm surface coverage)	16mm x 235mm (248mm surface coverage)
19mm x 142mm (127mm surface coverage)	19mm x 142mm (127mm surface coverage)	19mm x 184mm (165mm surface coverage)	19mm x 184mm (165mm surface coverage)	
19mm x 184mm (165mm surface coverage)	19mm x 184mm (165mm surface coverage)			

Available in random lengths varying from 1.22 to 4.88 metres.

INSTALLATION REQUIREMENTS

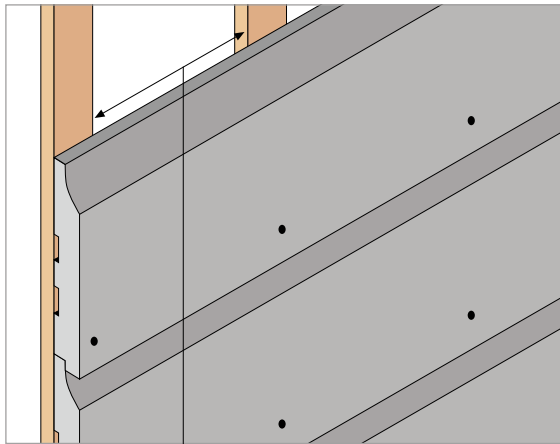

The board should be nailed once tightly fitted with the adjacent board.

19mm x 64mm battens spaced 405mm on centre

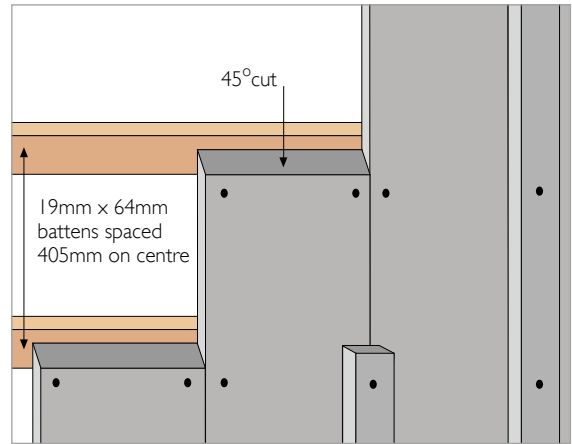

Bevel, V-joint, Channel, Cove

Board and Batten

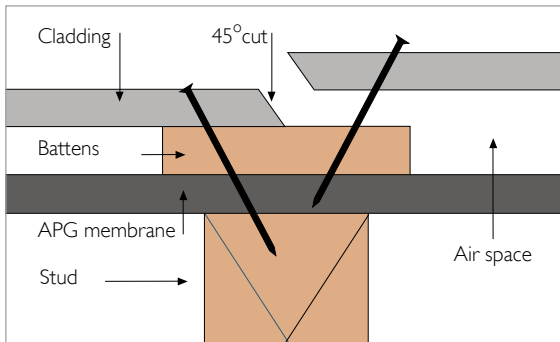

Contact A. Proctor Group Ltd for complete installation requirements.

Nailing

One nail placed between 19mm and 25mm from the base of board

184mm cladding requires a second nail placed 64mm from the top

Nailing

Use two nails placed between 19mm to 25mm from the edge of each board

Nailing of batten
Use 1 nail inserted in the middle of the batten every 405mm on centre

TRIMS, MOULDINGS AND NAILS

maibec® cladding, durable, affordable and complete with mouldings and trims, colour-matched nails and touch-up stain.

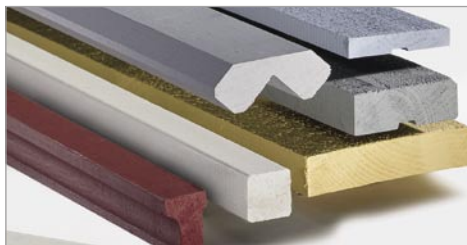

Available with the matching colour of your choice.

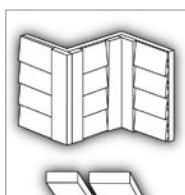

Inside or outside corner

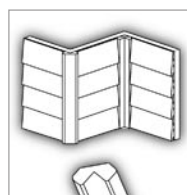

Inside or outside corner

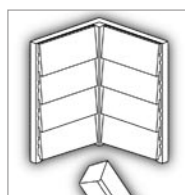

Inside corner

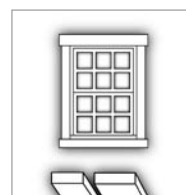

Window mouldings



Skirt board trim

Available with the matching colour of your choice.

INNOVATION BUILT ON EXPERIENCE



The Haugh
Blairgowrie
Perthshire
PH10 7ER

telephone
01250 872 261

email
askcladding@proctorgroup.com

www.proctorgroup.com

apg5684



All drawings are for illustration purposes.

Photo Credits –

Front cover (first from left) Ermitage Hotel at Lake Mont-Tremblant developed by Intrawest Placemaking

Back cover (first from left) Craigleith Ski Club at Collingwood.

© Registered trademark



METAL ROOFING
CONSTRUCTION MEMBRANES
THERMAL INSULATION
GEOSYNTHETIC ENGINEERING
ACOUSTIC INSULATION
VIBRATION ISOLATION
TIMBER CLADDING