



COMPETITIVE ADVANTAGES

SECTIONAL DOORS

- TECHNICAL FEATURES
- SANDWICH PANELS BY ALUTECH
- DOOR LEAF COMPONENTS
- WICKET DOOR
- TRACK AND SUSPENSION SYSTEM
- BALANCING SYSTEM
- KITTING AND SAFETY SYSTEMS
- DOOR PACKING

Modern production is the basis for the high quality of ALUTECH sectional doors

The Alutech Group of Companies produces all main components for sectional doors, i. e. sandwich panels, tracks, end profiles, connecting plates and brackets.

Due to the inhouse production it is possible to control the quality of product at all stages of its life-cycle, i. e. from designing until its delivery to clients.

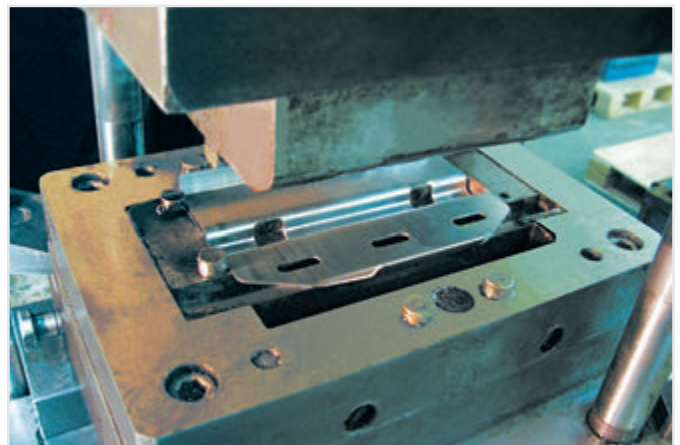

Production line of sandwich panels

Alutech sandwich panels are produced on the modern high-productive line of the Siempelkamp company (Germany), one of the leading world producers.

The whole range of sandwich panels is produced on this line, i. e. microwave, S-ribbed, M-ribbed, L-ribbed and cassette ones.

Production of steel profiles

14 types of profiles are produced on the automated roll-forming line (e. g. track profiles, C-profiles, profiles for telescopic suspension, etc.)

Due to the line it is possible to produce steel profiles with high accuracy of sizes and without any damage to the zinc coating.

Complex for steel tape colouring

70 000 tonnes a year is the production capacity of the complex for colouring steel strips that are used to produce sandwich panels.

The tape undergoes multiphase preparation and special treatments that provide all necessary surface characteristics (colour, texture and brilliancy), strength and resistance to abrasions or ultraviolet.

Production of steel components

Connecting plates, brackets for installing torsion shafts and telescopic suspensions are manufactured on high-precision equipment for forming.

Due to the equipment it is possible to produce components of high quality and to introduce quickly new developments.



COMPETITIVE ADVANTAGES OF ALUTECH SECTIONAL DOORS



Sectional garage and industrial doors are modern, reliable and easy to use

The innovative approach to designing and production of every unit for Alutech sectional doors ensures ease of their installation, their high technical and operation characteristics.

Door durability and safety depend on the construction, i. e. on the following main elements:

1. a door leaf composed of sandwich panels with side caps on the ends, intermediate hinges, roller brackets and end profiles with seals;
2. system of track profiles along which a door leaf moves while being opened or closed;
3. balancing system of a door leaf (torsion or tension springs);
4. safety system;
5. packing.



Alutech sectional doors fully comply with all the requirements of European safety standards:

- EN 12604;
- EN 12453;
- EN 12424;
- EN 12425;
- EN 12426.

This is confirmed by certificate and test reports issued by the accredited laboratory of the Scientific Research Institute NISI (Bulgaria).

CE mark indicates that a product is absolutely safe for consumers and environmentally friendly.

1

Technical Features

The Alutech sectional doors tests conducted in NISI, Bulgaria

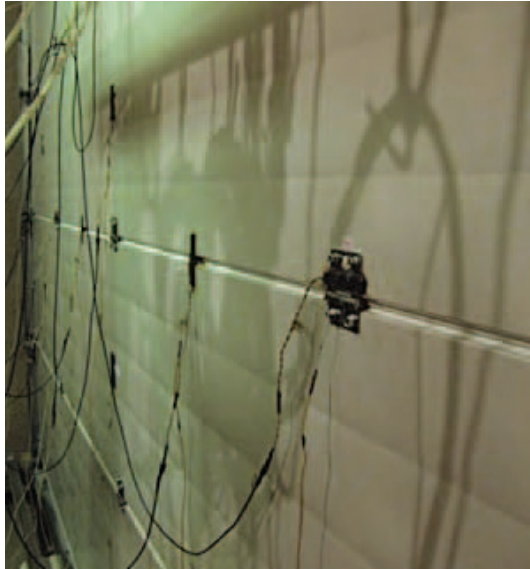

Effective heat-insulating

High heat-insulating properties of Alutech sectional doors are confirmed by numerous tests conducted by the accredited European laboratory of NISI, Bulgaria.

The coefficient of thermal transmittance (U) of Alutech sectional doors is $0.61 \text{ W/m}^2 \text{ K}$ that is comparable to a 60 cm thick brick wall.

Maximum sound insulation class



High sound-insulation

Sound insulation of Alutech sectional doors is 21dB (EN ISO 717-1).

The highest class of wind resistance



Maximum wind resistance

Resistance of Alutech doors to wind loads is 1000 pascal that conforms to the highest Class 4 (by EN 12424).

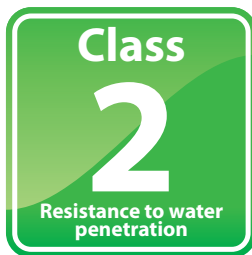

Resistance to water penetration

Resistance to water penetration of Alutech sectional doors is 50 Pa, that conforms to Class 2 (EN 12425).



Air permeability

Air permeability of Alutech sectional doors conforms to (EN 12426).

ALUTECH Sandwich Panel



Unsurpassed strength

- 1** Alutech sandwich panel is one of the highest strength and durable panels in Europe. Its thickness is 45 mm that ensures high resistance to wind and impact loads as well as high heat and sound insulation.
- 2** The inner space is evenly filled with freon-free foamed polyurethane. Its high density of 46 – 47 kg/m³ determines rigidity of a door leaf and high resistance to deformations.
- 3** Every sandwich panel is fitted with polymer EPDM-seal that preserves high mechanical strength and elasticity at low temperatures. The seal eliminates gaps between panels and guarantees high thermal and sound insulation.

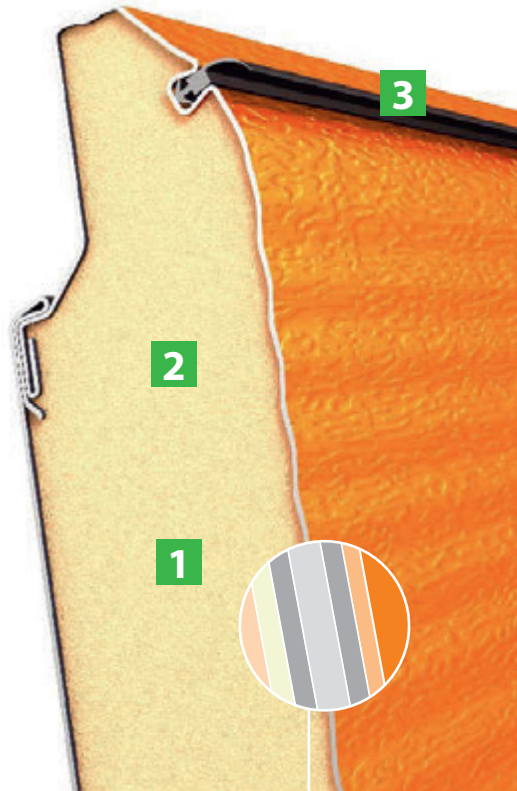

Structure of Alutech sandwich panels

Multilayer protection

Alutech sandwich panels are produced from galvanized steel coils of 0.4 mm thick that guarantees high strength characteristics and durability of a door leaf.

Both a 16 mkm thick zinc coating and a double-layer polymer of 25-35 mkm reliably protect surface of sandwich panels against any mechanical damage or weather effect.

Polyurethane coating of 20-25 mkm
Ground of 5-7 mkm
Zinc of 16 mkm
Steel of 0.40 mm
Zinc of 16 mkm
Adhesional lacquer of 12 mkm
Foamed polyurethane of 46-47 kg/m ³

Structure of a steel leaf used for Alutech sandwich panels

High-quality coating

The front face of Alutech panels is enameled with polyurethane coating modified by polyamide particles (PUR-PA) that:

- 1.** is highly resistant to scratches and cuts caused by any mechanical action;
- 2.** is tolerant to temperature and humidity fluctuations;
- 3.** has great strength and elasticity;
- 4.** has excellent anticorrosion properties;
- 5.** is resistant to detergents and chemicals.

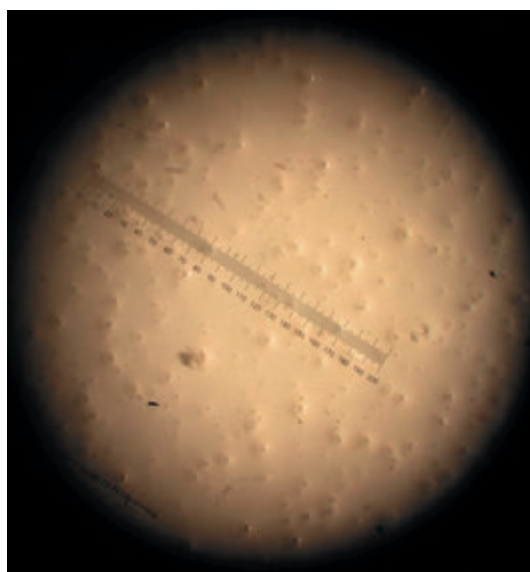

PUR-PA coating under a microscope

2

ALUTECH Sandwich Panel

Environmental camera in BelNIIS, Minsk

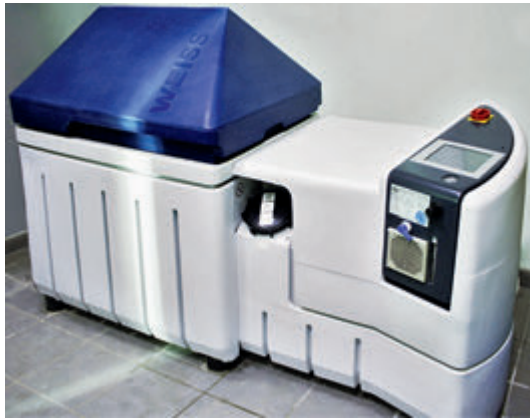

CORROSION RESISTANCE AND DURABILITY

Tests conducted in independent accredited laboratory of Republic Unitary Enterprise «Institute BelNIIS» (Minsk) proved that components of an Alutech door leaf can easily withstand the influence of coastal conditions for 750 hours that equals 15 years of door operation in any coastal and industrial regions that have high humidity and that are saturated with salts.

Door operation in places with high humidity



Air of coastal and industrial regions is high-humid and saturated with sea-salt aerosols. Every Alutech sectional door can perfectly withstand the impact of these factors and remain attractive for its operation life.

Closed contour of steel sheets

Self-aligning of panels

Reliable fixture of hinges

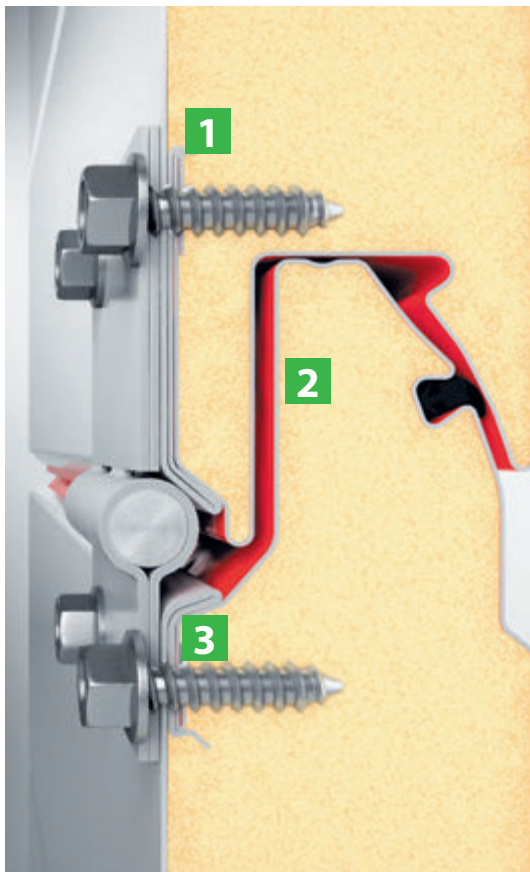

Perfect design of sandwich panels

- 1** Both outer and inner steel sheets of a sandwich panel are interconnected on its top and bottom. This closed contour eliminates separation of a panel due to sun heating that is very important for southern regions and dark-coloured doors.
- 2** Configuration of panels ensures their self-aligning. This allows to have door panels reliably connected to each other and enhances hermeticity and heat insulation of doors. All this makes door installation much easier and excepts errors when assembling a door leaf.
- 3** Places for screws are located where both outer and inner leaves (4 layers of metal) are jointed. This makes fastening more reliable and minimises hinge sag. Firm joint of steel leaves eliminates panel delamination if a door has been abruptly closed.

The unique structure of an Alutech sandwich panel offers a range of advantages for both an end customer and an installation company.

Ease of installation

Panels are supplied with holes for screw hinges, brackets, locks and other accessories. These factory-made holes make door installation much easier and faster. This is especially important for industrial sectional doors.



Factory-made holes

Operating safety

The design of an ALUTECH panel ensures protection against finger trapping that is the obligatory requirement of European safety norms (EN12604). This protection is highly important for garage doors with a motor.



Protection against finger trapping on inner and outer side of doors

Protection against scratches

Sandwich panels are covered with a protective film on both sides to avoid any damages while transporting or installing doors.



Protective film on a door panel

Good look of doors for many years

The exterior side of RAL-coloured panels has a woodgrain embossment. Small scratches made in operation become invisible due to the embossment.



Woodgrain embossment

3

ALUTECH door leaf

Upper roller bracket of CLASSIC garage doors



Tight coupling of a door leaf to passage

The unique construction of an upper roller bracket for garage doors affords adjustment in two planes, i. e. horizontal and vertical.

Side roller bracket of garage doors



No draughts

Adjustable side brackets of ALUTECH sectional doors ensure tight coupling of panels to passage. This protects against draughts and undesirable heat loss.

Bottom roller bracket of CLASSIC garage doors

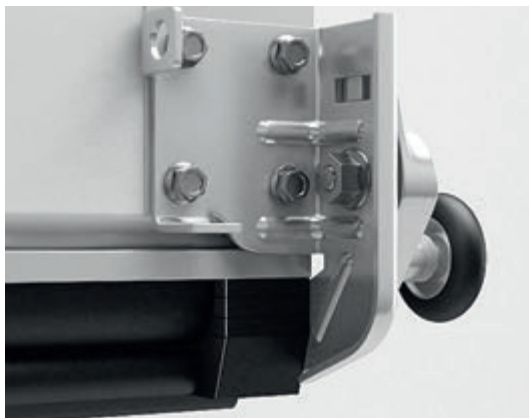

Easy regulation

It is possible to regulate bottom, side and upper roller brackets without any difficulties when installing or operating doors. Service maintenance is easy, effortless and requires little equipment or time.

Intermediate hinges and roller brackets made of stainless steel



Stainless accessories in a standard set

Intermediate hinges and roller brackets of garage and industrial doors are made of stainless steel. This guarantees high corrosion resistance for rubbing elements of hinges and brackets for the whole product life.

Operational characteristics are affected by sandwich panels as well as by other structural elements of a door leaf (roller brackets, intermediate hinges, side plates, seals of passage)

Reinforced intermediate hinges

Intermediate hinges have special construction as one piece formation this ensures high strength of hinges and eliminates their sagging and twisting. Tests proved that one intermediate hinge can withstand a tension load of 7000 N or ~715 kg.

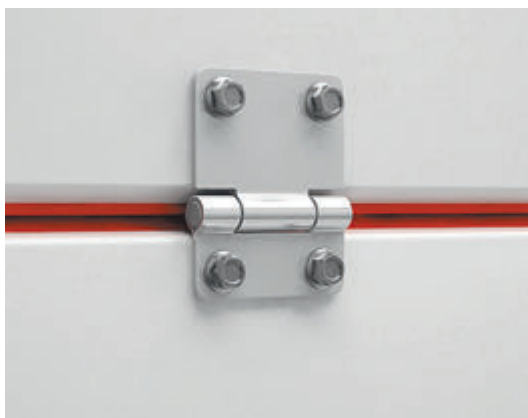

Intermediate hinge of one piece configuration (for industrial and CLASSIC garage doors)

Reliable sealing

ALUTECH sectional doors have special seals of elastic polymeric rubber located along the entire door perimeter to ensure reliable sealing for passages. Side and upper seals of doors have two leaves that ensures better insulation of doors for heat and sound.

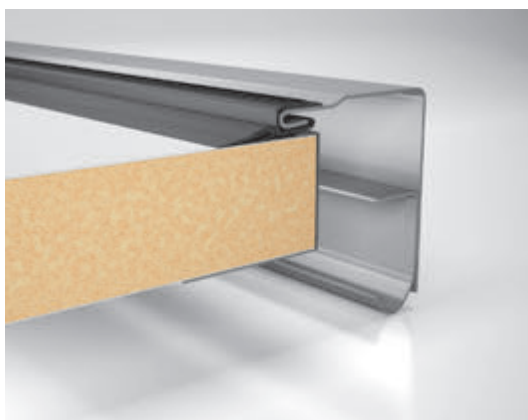

Rubber seals on the whole perimeter of a door

Excellent seal

A bottom seal of a special form hides floor irregularities and ensures reliable door sealing. The seal has a cavity for optical sensors that affords to shut down a drive when a door leaf touches an obstacle.



Bottom seal (for industrial and GLASSIC garage doors)

Protection against excessive deformation

The door construction includes adjustable stops to protect the bottom seal against excessive deformation and to preserve optical sensors when they are used in doors.



Regulated stop (for industrial and CLASSIC garage doors)

4

Wicket

Wicket allows to come in and go out from the premises without opening the doors. At the same time it helps to keep warmth inside the premises and prolongs the period of operation for the doors.



Innovative approach from Alutech offers substantially better operational characteristics of the wicket

- 1** Application of reinforcing profiles in the wicket door framing. Visible part of the framing profiles is only 40 mm. Narrow profiles of the wicket door framing make it look elegant and attractive;
- 2** between the panels there are plastic caps which guarantee absence of gaps between profiles of the wicket framing and protection from finger trapping;
- 3** application of a special safety gear which excludes the sagging of the wicket at its using. It guarantees safe and long-term operating of the wicket;
- 4** to provide rigidity and durability of the wicket door curtain steel reinforcing profiles are used from the inner side of the doors. Profiles are painted white-and-grey (close to RAL9002), it ensures high anticorrosion properties and esthetic doors design from inside;
- 5** above the wicket door curtain from the outside there is a canopy to protect the premises from water when it rains;
- 6** the locking mechanism includes metal ergonomic handles to ensure safe and long-term operating. Distance from the wall is 64 mm (except high and vertical mounting types) which is convenient for operating;
- 7** all doors are equipped with inbuilt sensors of wicket positioning. Wicket sensor turns off the electric drive if the wicket is open or only partially closed. Such safety measures allow to avoid the damage of the doors and injury of the personnel;



Track and suspension system

5

There are 10 variants of a track system (10 types of installation). ALUTECH doors can be installed in places with a low headroom, a high ceiling or an inclined roof.

Unique track system

Our own development of tracks make them more technologically advanced and easier to install. For example:

1. A panel strip is fastened without additional brackets that makes an installation easier and improves the accuracy of frame assembling.
2. Extended radius of track profiles ($R = 14 \text{ mm}$) ensures reliable and smooth motion and eliminates roller hitting against fastening elements.



A panel strip and a track profile of garage doors

Zinc covering of more than 20 mkm

Track profiles are made of high-quality steel with zinc covering of 18 – 22 mkm. This ensures nice functionality and good look of a door for many years even if operated in humid conditions.



ALUTECH sectional doors installed in a car wash

Accuracy of installation

Factory-made holes for track assembling ensures accuracy of door installation and its reliable, safe and silent operation.



Angle for garage doors

Reliable and firm joint

Screw joints were replaced with reliable and strong rive-set ones. As a result, there are no protrusions on the operating surface that could prevent roller travel.

Rive-set joints don't damage galvanic anticorrosion covering of profiles.



Rive-set joint of a track system

6

Balancing system of a door leaf

Easy to open
and close
a door



Ideal balancing

The unique ALUTECH estimating program of springs ensures ideal door balance. The necessary effort to open a sectional door is less than 100 – 250 N (~10-25 kg), and a door leaf weight is up to 500 kg.

Minimum life
time of springs is
25 000 of open-
close cycles.



Long-lasting operation life

Minimum life time of springs for ALUTECH doors is 25 000 of open-close cycles. If to open a door 4 times a day it will operate at least for 17 years.

Torsion
spring



Increased endurance

Life-time of torsion springs can be enhanced up to 100 000 of opens/closes. This is necessary if doors are used very often (in car washes, service stations, parking passages).

Adjustable
coupler

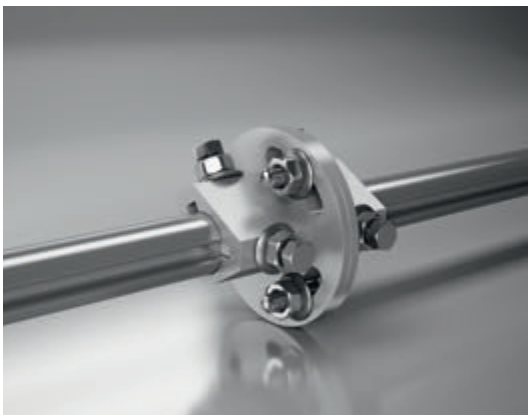

Easy regulation of rope tension

Constituent shafts are jointed with an adjustable coupler. It permits to turn shaft parts independently from each other when installing a door ensures the balanced tension of two lifting cables.

A spring mechanism is used to balance (compensate) leaf weight of a sectional door

Sixfold safety factor

Steel tension cables with sixfold safety factor are used for ALUTECH doors. This provides protection against rope break and ensures door safety.

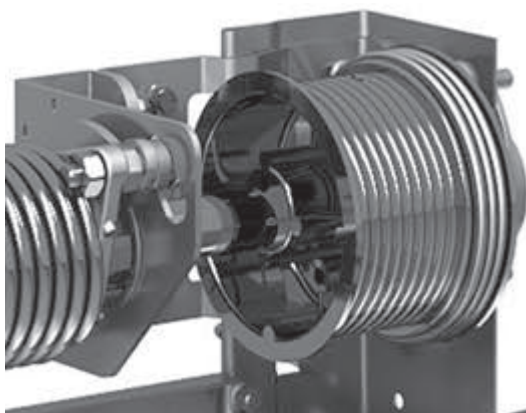

A spool with a tractive rope

Ease of installation

Tension springs installations are completed within 2 -2.5 hours due to the absence of torsion shafts.



Tension spring (for STANDARD garage doors)

Effective safety

The «spring-in-spring» system ensures protection against leaf falling as well as against bounce of springs, if one is broken.



The «spring-in-spring» system

Spring tension

It is possible to reinforce or loosen spring tension directly while installing a door or within its operation life. The door will be easily opened and closed for many years. The unique method of spring fastening is patented.



7

Kitting and safety systems

Compliance with European safety standards



Safety of the European level

The design of ALUTECH sectional doors is fully compliant with European safety standards EN 12604 and EN 12453, i. e. protection against finger-trapping, snagging, cutting, falls and uncontrollable leaf moves.

Ratchet coupling as protection against spring breakage



Extended standard set of garage doors

The standard kit (base prices) of a sectional door contains protection system that blocks a shaft and prevents a door leaf from falling if a torsion spring breaks.

Bottom roller bracket with protection against rope breakage



Safety systems of industrial doors

The standard set for industrial doors includes:

- a protection device against door falling due to a spring breakage;
- a protection system against door falling due to a cable breakage.

Shutdown sensor of a drive in case of spring breakage



Safety of doors with drive

An automated industrial door is equipped at no extra surcharge with sensors of rope tension that shut down a drive, if ropes are loosened or broken as well as if torsion springs break. This ensures complete safety of door operation.

Quality packing

If a door width is more than 5 m, its sandwich panels are packed in a vertical wooden pallet and are tightly fixed in it.

The package allows to automate handling operations that is very important for industrial doors of big sizes.



Vertical pallet with sandwich panels

Protection of sandwich panels

A door with the width of less than 5 m is packed in a horizontal pallet. Sandwich panels are reliably protected against any mechanical damages with fibreboards. This compact and practical package allows to use a vehicle more efficiently.



Horizontal packing of a door leaf

Practical packing of door components

Pallets with panels, springs and boxes with other components are reliably protected against any weathers due to the polyethylene film. This eliminates corrosion of door components and extends the product durability.



Box with components

Compact size

The detachable radius profile reduces the risk of track damage while transporting and allows to minimize package size.



Detachabile radius profile



The Alutech Door Systems



The Alutech Incorporated



The AluminTechno



The Alstrong

The Alutech Group of Companies is one of the market leaders in Western and Eastern Europe for roller shutters and sectional doors, the largest manufacturer of aluminium profile systems in Eastern Europe. The Alutech Group of Companies includes five manufacturing facilities and twenty-five retail companies in Russia, Belarus, Ukraine and the Czech Republic.

All the enterprises of the Group have high-tech equipment to manufacture products that meet all European quality standards. It includes modern high-production line of sandwich panels for sectional doors, roll forming lines, ultra – modern complex to colour and to cut aluminium tape, high-tech production line of aluminium extruded profiles, automated systems to cast aluminium alloys, modern powder coating line and the largest in Eastern Europe complex to anodize aluminium profiles.

Due to industrial complexes within the holding company the specialists of The Alutech Group of Companies are able to monitor product quality at all stages of the production, i. e. from raw materials purchases to finished products and packaging. The Quality Management System for all the enterprises is certified to the International standard ISO 9001 under TÜV CERT system.

The Alutech Group of Companies actively develops new markets due to the products that meet international quality standards.

Today Alutech sectional doors are in high demand in Eastern Europe, Baltic countries, Germany, France, Austria, the Netherlands, the Czech Republic, Denmark and other European countries.

WWW.ALUTECH-COMPANY.COM

The compliance of the Company Quality Management System with the requirements of the standard ISO 9001:2008 is confirmed by the certificate TÜV Rheinland InterCert No. 75 10070322



The **ALUTECH** Group of Companies

The Alutech Door Systems, LLC

Tel.: +375 (17) 2996222

Fax: +375 (17) 2996071

E-mail: info@alutech-doors.by

Distributed by JD (UK) Ltd - www.jdukLtd.co.uk info@jdukLtd.co.uk 01924 472924