

TYPICAL VIEW OF FLOATING FLOOR ASSEMBLY

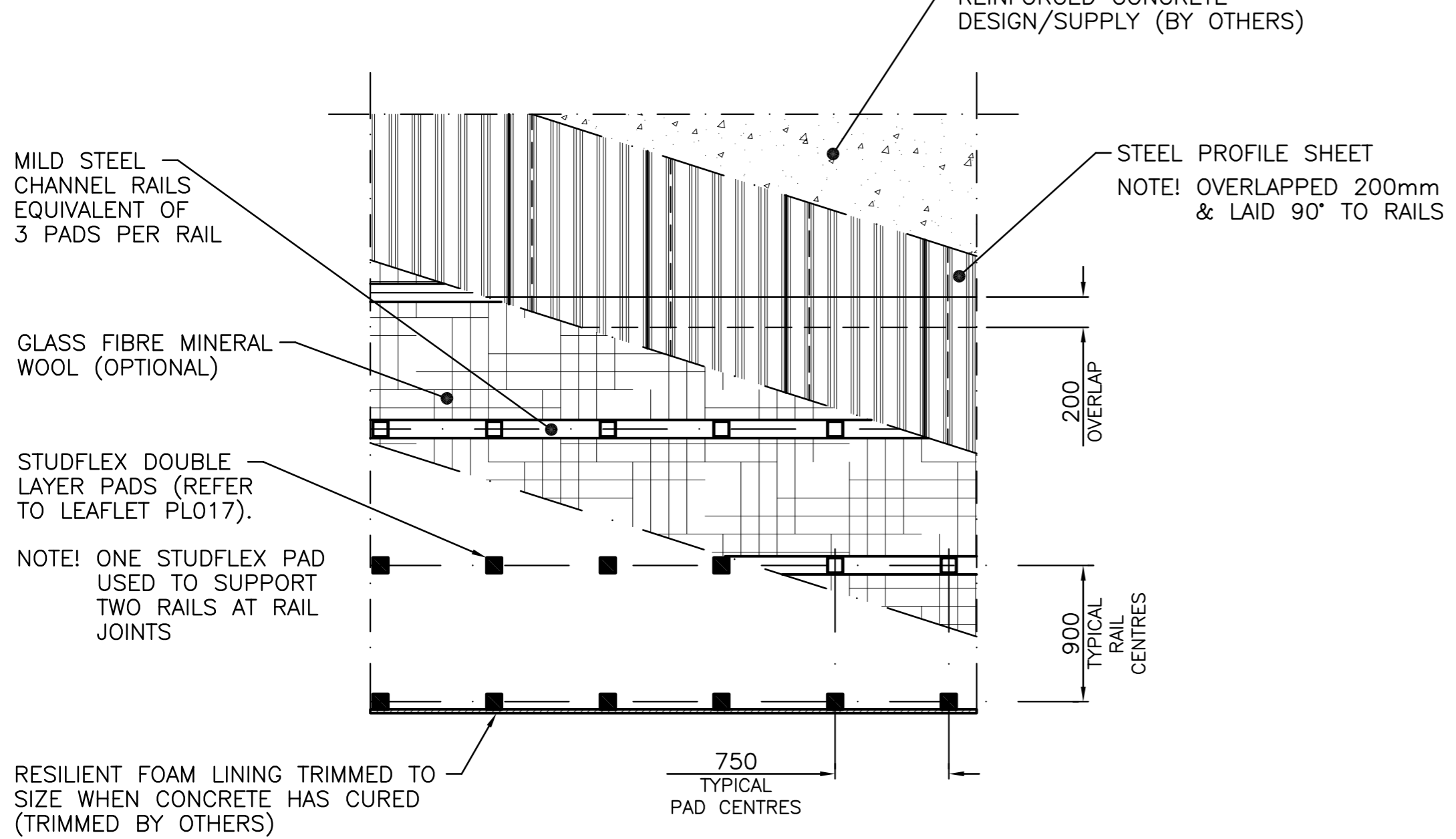

DETAILS OF FLOATING FLOOR IN SECTION

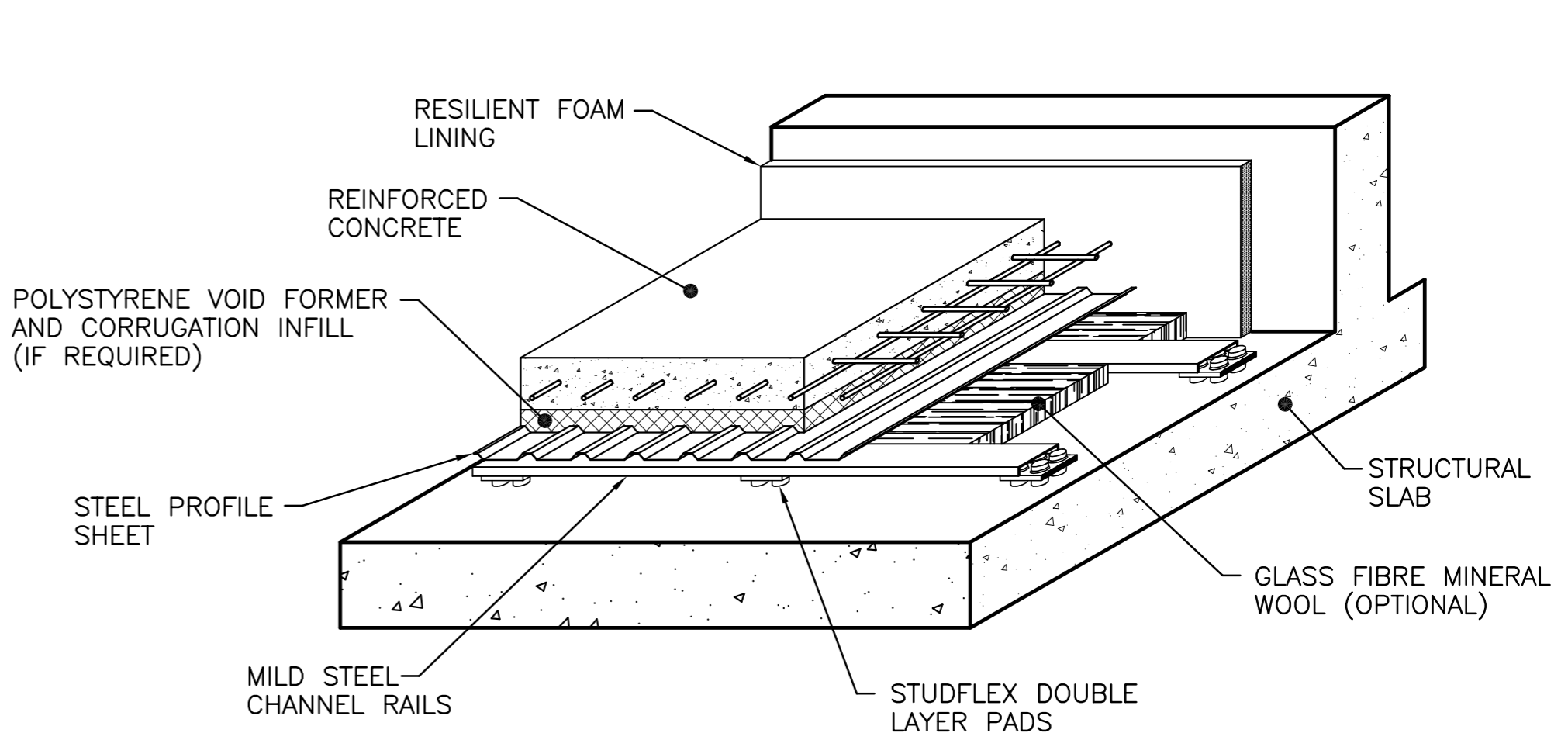

ENLARGED VIEWS OF PADS/STEELWORK

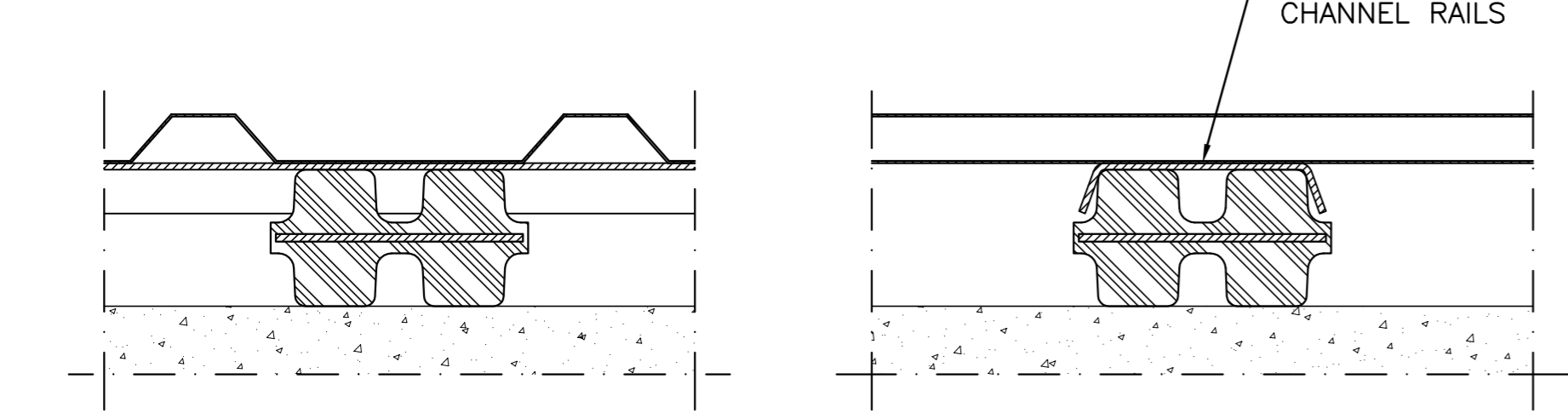

SECTION THROUGH FLOATING FLOOR

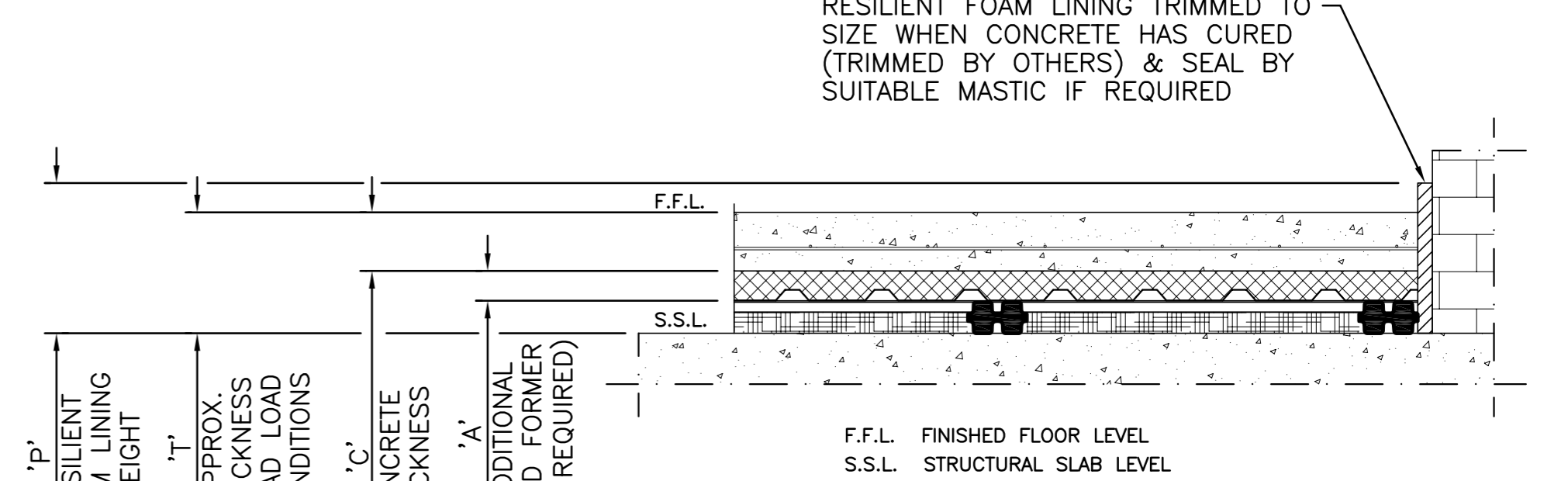

INSTALLATION IS TO BE CARRIED OUT IN ACCORDANCE WITH CHRISTIE & GREY DATA SHEET DS 036

THE EFFICIENCY OF AN ISOLATOR SYSTEM CAN BE SERIOUSLY IMPAIRED IF THE SYSTEM IS CONNECTED TO RIGID PIPES, ELECTRICAL CONDUITS, DUCTS OR SHAFTS. IT IS ESSENTIAL THAT SUCH EXTERNAL CONNECTIONS BE AS FLEXIBLE AS POSSIBLE, NOT ONLY TO PREVENT TRANSMISSION OF VIBRATION THROUGH THE CONNECTIONS AND ALLOW THE SYSTEM FREEDOM OF MOVEMENT, BUT ALSO TO AVOID POSSIBLE FAILURE OF THE CONNECTIONS.

IT IS IMPORTANT THAT NO WATER, OIL OR SOLVENT BE ALLOWED TO CONTAMINATE THE AREA TO BE ISOLATED DURING OR AFTER INSTALLATION OF THE FLOATING FLOOR. MINERAL OIL WILL CAUSE RUBBER TO SWELL AND DETERIORATE. WATER MAY CREATE A HYDRAULIC LOCK WITHIN THE 'STUDFLEX PAD LAYOUT REDUCING ITS EFFICIENCY.

IMPORTANT ALL AREAS TO BE DRY & CLEAR/FREE FROM DEBRIS PRIOR TO THE COMMENCEMENT OF LAYING THE CHRISTIE & GREY FLOOR MATERIALS.

TYPICAL INSTALLATION INSTRUCTIONS FOR SRS TYPE FLOATING FLOOR WITH PROFILE SHEET LARGE CORRUGATIONS DOWN

i.e. : LARGE CONCRETE VOLUME

DIMENSIONS IN MILLIMETRES (mm) UNLESS OTHERWISE STATED

Rev.	Date	Description	C/Note
J	08/07/09	Update Pads Per Rail Length	072
H	04/09/08	Update Pad Centres	099
G	25/06/07	Update Pad Centres	085
F	12/01/07	Update Pad Centres, Profile & Void Former	007

NON-CONTROLLED UNLESS STAMPED OTHERWISE.
DO NOT SCALE, IF IN DOUBT ASK.



Morley Road, Tonbridge, Kent, TN9 1RA.
Tel : +44 (0)1732 371100
Fax : +44 (0)1732 359666
E-mail : sales@christiegrey.com

Job Number	Scale	Drawn	Checked
-	N.T.S.	A.R.B	M.T.P
Status	Date of Original Issue		
STANDARD	12/02/1998		
Drawing Number	Revision		
S 096	J		

Drawing Number	Revision	First angle projection	
S 096	J		