

DIMENSIONS IN MILLIMETRES (mm) UNLESS OTHERWISE STATED
 TOLERANCES EXCEPT WHERE OTHERWISE STATED $\pm 0.25\text{mm}$
 NON-CONTROLLED UNLESS STAMPED OTHERWISE.

First angle
 projection

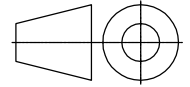

Q C F 6 0 - S S C E 3

DETAILS OF TYPE CRM2 HANGER

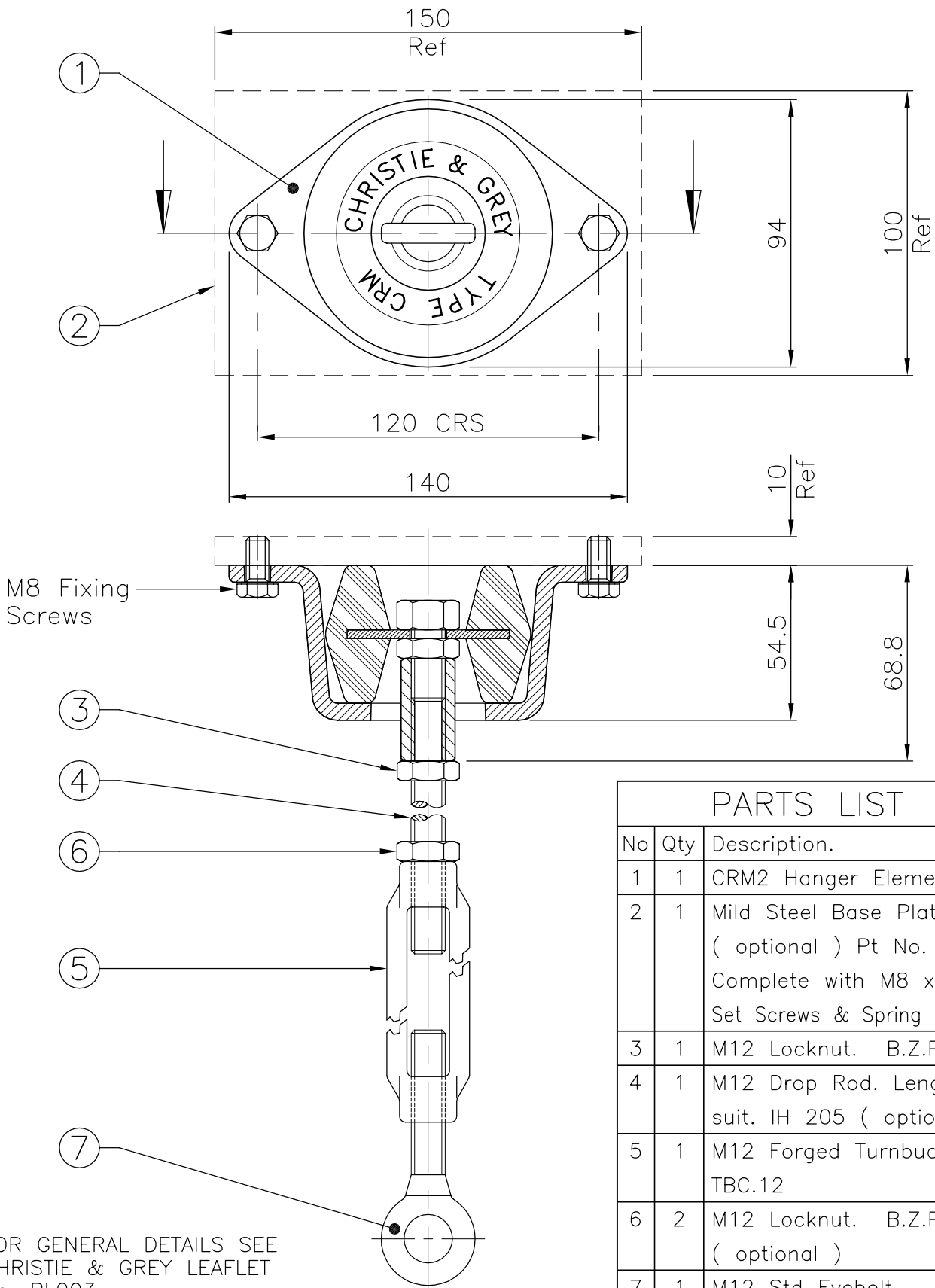

PARTS LIST

No	Qty	Description.
1	1	CRM2 Hanger Element
2	1	Mild Steel Base Plate (optional) Pt No. 4149 Complete with M8 x 16 Lg Set Screws & Spring Washers
3	1	M12 Locknut. B.Z.P.
4	1	M12 Drop Rod. Length to suit. IH 205 (optional)
5	1	M12 Forged Turnbuckle TBC.12
6	2	M12 Locknut. B.Z.P. (optional)
7	1	M12 Std Eyebolt.

FOR GENERAL DETAILS SEE
 CHRISTIE & GREY LEAFLET
 No. PL003.

Drawing No. S 080	A	B	C	D	E	Job No.	 Engineers in vibration, noise and shock control. Christie & Grey Morley Road, Tonbridge, Kent, TN9 1RA England
	23/01/95	02/10/95	19/02/99	11/06/02	02/11/05	Scale 1 : 2	
Change note No.	174	082	155	138	Checked P.J.B	Drawn A.B.	