



Anderton
CONCRETE PRODUCTS LTD

• RETAINING WALL SOLUTIONS • FENCING & BUILDING PRODUCTS • RAILWAY PRODUCTS

Welcome

Anderton Concrete Products has its roots deeply set in traditions, manufacturing excellence and dedication to customer service that have existed for many years.

The company has been manufacturing precast concrete products for over 50 years and as such, the name Anderton Concrete Products, has become synonymous with product quality and deliverability.



Anderton Concrete Products Ltd is a market leading manufacturer of concrete rail products, fencing materials and retaining wall systems with an unrivalled reputation for quality, design and innovation. The company supplies a vast range of sustainable precast products to every sector of the construction industry; fully supported by our experienced sales & technical team, we have built long-term partnerships with our customers and suppliers including major contractors, the rail industry, the Ministry of Defence and national merchant distributors.

CONCRETE PRODUCTS

- **Concrete Retaining Wall Systems** including: Keystone / Stepoc / Slope-loc
- **Concrete Fencing & Building Products** including: Litecast / Slotted Fence Posts & Gravel Boards / Wall Copings / Pier Caps / Lintels & Padstones / Inspection Chambers
- **Concrete Railway Products** including: Cable Troughs / Apparatus Case Bases
- **Miscellaneous Pre-cast** including: Bespoke Products / Cable Protection & Identification / Utility Ducting

Index



1

General

Health & Safety Policy	4
Environmental Policy	5
Quality & Mission Statement	6

2

Retaining Wall Systems

Overview	8
Stepoc	9 - 11
Keystone	12 - 14
Slope-Loc	15 - 16

3

Fencing & Building

Overview	18
----------	----

FENCING PRODUCTS

Litecast Slotted Posts	19 - 20
Wet Cast Slotted Posts	21
Semi-Dry Slotted Posts	22
Gravel Boards	23
Closeboard Fencing	24
Universal & Holed Posts	25
Repair Spur	26
Chainlink Posts	27
Strained Wire Posts	28
Fast-Set Post Mix	29

BUILDING PRODUCTS

Lintels & Padstones	30
Inspection Chambers	
Rectangular Inspection Chambers	31
Chamber Sections, Reducers & Cover Slabs	32
Frames & Covers	33
Wall Copings	34
Pier Caps	35
Ancillary Building Products	36

4

Railway Products

Overview	38
Anderlite	39 - 40
Interloc	41
Trough Straight	42
Lid Straight	43
Trough Tee	44
Lid Tee	45
Trough Curved	46
Lid Curved	47
Trough Transition	48
Lid Transition	49

COMPLIMENTARY PRODUCTS

Ballast Boards	50
King Boards	51
Standard Catchpits	52 - 53
Matisa Catchpits	54 - 55
Large Apparatus Case Base	56
Small Apparatus Case Base	57
Corner Units & Filler Blocks	58
Point Rod Rollers	59
Miscellaneous Rail Products	60
Station Platform Materials	61
London Underground Products	62

5

Miscellaneous Precast

Overview	64
Utility Ducting	65
Cable Protection & Identification	66 - 67
Beam & Block Floor Ancillaries	68

Location Map & Contact Details	69
--------------------------------	----

All product dimensions are in mm unless otherwise stated.

HEALTH & SAFETY POLICY

ANDERTON CONCRETE PRODUCTS LTD seeks to achieve industry best practice standards of health and safety. We recognise that this is a critical issue for all of our stakeholders, particularly for our employees and contractors.

Our health and safety policy, applied throughout the company, is to:

- Comply, at a minimum, with all applicable legislation and continually improve our health and safety stewardship towards industry best practice
- Ensure that our employees and contractors respect the Company's health and safety imperatives
- Ensure that our company provides a healthy and safe workplace for our employees and contractors, and take due care of all customers and visitors at our locations
- Require all our company employees and contractors to work in a safe manner as mandated by law and industry best practice.

Health and Safety Management

Health and Safety Management is a daily priority of line management. Safety results for the company are closely monitored by senior management and are reported to the Anderton Concrete Products Ltd Board on a monthly basis.

Line management is responsible for ensuring that company health and safety policies are fully adhered to, and that site managers and employees, supported by company safety officers, are trained in health and safety risk analysis and prevention.

Where accidents occur they are thoroughly investigated and corrective action is taken to avoid a recurrence. Lessons learned are actively shared via Safety Best Practice groups.



Safety Performance

We have found that the most common causes of accidents are slips, trips and falls, injury by falling and moving objects and improper manual handling; with additional care and attention by all, many of these accidents are preventable.

Our goal is zero fatalities and zero accidents. Due to the nature and size of our business, these are extremely challenging goals. We will continue to devote substantial management and employee time and all the appropriate resources to this area to progress company performance towards those targets.

Product Safety

The products delivered by Anderton Concrete Products Ltd, when properly used, present negligible health risks. Material Safety Data Sheets advising on optimal application procedures are available on request.

ENVIRONMENTAL POLICY

ANDERTON CONCRETE PRODUCTS LTD operates in an environmentally responsible manner. The resources and processes that we have put in place are focused on achieving industry best practice standards at all of our locations.

Our environmental policy, applied throughout the company, is to:

- Comply, at a minimum, with all applicable environmental legislation and continually improve our environmental stewardship towards industry best practice
- Ensure that our employees and contractors respect their environmental responsibilities
- Proactively address the challenges of climate change
- Optimise our use of energy and resources through efficiency gains and recycling
- Promote environmentally-driven product innovation and new business opportunities
- Be good neighbours in the many communities in which we operate.

Environmental Management

Achieving our environmental policy objectives at all our locations is a management imperative; this responsibility continues right up to the Anderton Concrete Products Ltd Board level.

Daily responsibility for ensuring that the Company's environmental policy is effectively implemented lies with individual location managers.

These personnel are charged with ensuring that company environmental policies are properly adhered to, and that site managers are fully aware of their responsibilities in this regard.



Environmental Performance

Anderton Concrete Products Ltd is committed to investing in a wide range of environmental improvements across all of our activities and areas of operation. Plant upgrades typically include process yield optimisation, increased recycling, better energy efficiency, abatement of emissions, together with improvements in ergonomics and safety. This sustained investment program steadily moves us towards best industry practice in all those areas.

Environmentally-driven Product Innovation

In tandem with our commitment to act as a socially responsible corporate citizen, the company views the development of products that specifically benefit the environment as a significant business opportunity. Consequently this area is a key driver in our sales and marketing strategies, and forms a key part of Best Practice exchanges between our operating companies. Significant environmental and commercial benefits are also gained through recycling of used materials.

Climate Change

We acknowledge the challenges that climate change presents to humanity and to our businesses and we are committed to playing our part in developing pragmatic solutions. In all our activities, increasing energy efficiency and reducing CO₂ emissions remains a major focus. We see climate change and high energy costs as twin innovative driving forces of the future and we recognise that the challenges of today can quickly become the opportunities of tomorrow. In addition, many of our core products can contribute to climate change mitigation and adaptation. On the broad environmental front we continue, through ongoing systematic plant upgrading, to make progress in increasing energy efficiency, reducing waste, optimising water usage and recycling more secondary materials and fuels. We believe all of these initiatives are not only environmentally-positive but also business-positive.

QUALITY & MISSION STATEMENT



QUALITY

The aims and objectives of the Quality System are:

- Reduce production costs by minimising defective elements, remedial work, and wasted materials
- To breed a culture of pride and confidence in our workmanship
- To assure our customers of a consistent and first class product

Standards of performance are not restrictive to the saleable product, but extend to all of our activities throughout the business.

The policy has the wholehearted support of the Directors and Management of Anderton Concrete Products Ltd.

MISSION STATEMENT

- Exceeding customer expectations by always being first to market with the best products.
- Partnering with our customers to make sure they succeed.
- Demanding that everything we do leads to a cleaner, healthier, safer environment.
- To promote good safe working practices within our industry.
- To raise the profile of concrete product manufacturing as a skilled industry.
- To liaise with the Health & Safety Executive and other bodies, including suppliers.
- Committed to ensuring customer satisfaction by continually improving performance in the development of products, quality, technique and service.
- To satisfy this commitment all employees must understand the importance and responsibilities of quality in their work, and utilise only those approved working practices which will assure the required quality standards are achieved.



Committed to ensuring customer satisfaction by continually improving performance in the development of products, quality, technique and service.



Accredited to BSI QMS

CPR & CE MARKING

Key Facts:

- From 1st July 2013 it became mandatory for any construction product, covered by a harmonised European Standard (hEN) containing a 'ZA' annexe, to carry a Declaration of Performance (DoP) and a CE mark.
- Products not covered by hENs but with a European Technical Approval (ETA) may be CE marked.
- Products not falling under the scope of a hEN or ETA must not carry a CE mark. However most construction products will eventually have a harmonised European Standard.
- CE marking is not a 'quality' standard, it simply confirms that a product has been manufactured to a performance standard that defines the characteristics of the product.

Anderton products covered by a harmonised European Standard and therefore requiring a CE mark are:

- Closure Blocks (EN 15037-2)
- Lintels (EN 845-2)
- Keystone (EN 771-3)
- Slope-loc (EN 771-3)
- Slips & Coursings (EN 771-3)
- Stepoc (EN 15435)
- Standard & BS Fencing Posts and Gravel Boards (EN 12839)
- DIC/IC (EN 1917)
- Path Edging (EN 1340)



In order to apply a CE mark to a product it is necessary to have in place a Declaration of Performance (DoP) and these can be accessed for the relevant products at our website location: www.anderton-ce.co.uk



2

RETAINING WALL SOLUTIONS

OVERVIEW - RETAINING WALLS

There are more occasions in the construction market today where there is limited ground for development, and a retaining wall may be specified to extend the area of level ground available for building. Alternatively, walls may be simply required to create terraces and attractive landscaping, particularly on the more prestigious developments. Anderton Concrete offers a whole range of retaining wall and soil reinforcement solutions to cater for these requirements.



Stepoc - Manufactured to harmonised standard EN 15435

THE REAL ALTERNATIVE TO SHUTTERED CONCRETE

A system of concrete shuttering blocks that are highly-engineered and dimensionally co-ordinated. Stepoc is designed to readily accept vertical and horizontal reinforcement for use where structural performance is the prime consideration and offering cost savings on both time and labour.



Keystone - Manufactured to harmonised standard EN 771-3

REPLACES GABION, CRIB AND CAST-IN-SITU WALLS

The number one retaining wall system on the market today; available in a range of finishes and colours providing practical solutions for low-level gravity walls through to tall structural walls in both the domestic and commercial markets.



Slope-Loc - Manufactured to harmonised standard EN 771-3

A STYLISH MODULAR HARD FACING TO SOIL SLOPES

Slope-Loc provides either a simple solution for low level gravity walls in the domestic DIY sector or an engineered solution for taller walls where an alternative to vertical walls is preferred.

STEPOC



THE REAL ALTERNATIVE TO SHUTTERED CONCRETE.

Stepoc's unique design enables reinforcement to be positioned in order to maximise the engineer's design.

Stepoc is filled with concrete, which is pumped down through the inter-connected cavities in the blocks. The blocks' unique design creates a cascade or waterfall effect which ensures a smooth filling of the pumped concrete, forcing out air and eliminating segregation, to create walls which have immense compressive and lateral strength. Stepoc walls have achieved the highest rating for a Security Barrier System under the SEAP (Security Equipment Assessment Panel) testing regime.

Stepoc enables the fast construction of single skin retaining walls up to 4.0 metres high, subject to a design carried out by a structural engineer. Stepoc can be filled in a single pour from 1.8 - 2.25m depending on block thickness. Stepoc is available in three widths, 200, 256 & 325mm and at less than 20kg per unit.

Stepoc is proven in use on applications the length and breadth of the UK and has the backing of an experienced team with a wealth of knowledge in the construction industry. Stepoc combines the ease of blockwork construction with the versatility of in-situ concrete, and yet is faster to apply than both, making it an ideal component for :

- Retaining walls
- Basement walls
- Flood Alleviation Schemes
- Swimming pools
- Laterally-loaded panels
- Blast panels
- Lift shafts
- Platform edges

T: 01606 535300
F: 01606 75905
E: civils@andertonconcrete.co.uk
W: www.andertonconcrete.co.uk

Anderton
CONCRETE PRODUCTS LTD

STEPOC



TYPE 200

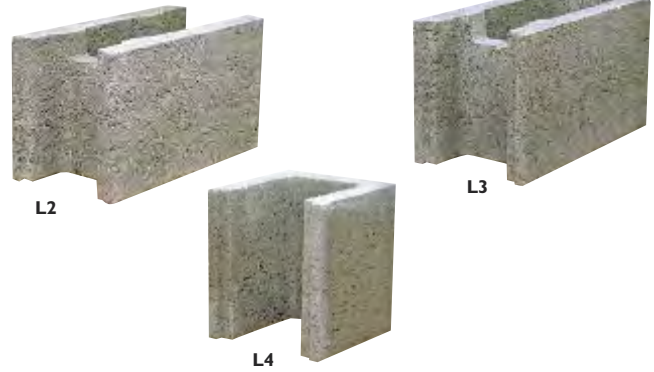

- L2 - Full Length Standard
- L3 - Full Length Plain End
- L4 - Half Length Plain End



Flood Relief Scheme, Chelmer Village



Brick Clad STEPOC

Pour Heights

There is a maximum height for each pour so that stability is not lost in the dry laid blocks as they are filled. Lower heights for each pour can also be used. The maximum heights are:

200 Stepoc - 8 Courses	= 1.80m
256 Stepoc - 10 Courses	= 2.25m
325 Stepoc - 10 Courses	= 2.25m

If multiple concrete pours are required, the concrete of the previous pour should finish 50-75mm from the top of the course of Stepoc, with the vertical bars projecting the equivalent of a splice, length taken from the engineer's schedule. This is to ensure a proper key between consecutive pours.

STEPOC

TYPE 256



V2 - Full Length Standard
V5 - Third Length Standard

V3 - Full Length Plain End
V6 - Third Length Plain End

TYPE 325



Z2 - Full Length Standard
Z4 - Half Length Standard

Z3 - Full Length Plain End



STEPOC in a basement level application



STEPOC in a multi-storey development



Wine Cellar using 256mm STEPOC

Concrete Mix

The concrete should possess the characteristic strength specified by the structural engineer who has carried out the design of the wall, but not less than 35N/mm²

Block type	Concrete Infill
200mm	0.12m ³ per m ²
256mm	0.15m ³ per m ²
325mm	0.19m ³ per m ²

The concrete should be designed to be suitable for the specific means of delivery, possessing a slump of no less than 150mm. The maximum aggregate size should not exceed 10mm and the mix should contain no less than 300kg of cement per cubic metre of fresh concrete.

Filling is best accomplished by a concrete pump or skip with a 75mm nozzle, and the design of the concrete should take this into account. Mechanical vibration must not be used. The use of water reducing agents is acceptable to lower cement content in the mix design.

TYPE	Unit	Length	Width	Height	Weight (kg)
200	L2	400	200	225	17.3
	L3	400	200	225	16.9
	L4	200	200	225	8.4
256	V2	400	256	225	19.7
	V3	400	256	225	19.9
	V5	133	256	225	7.5
	V6	133	256	225	7.6
325	Z2	325	325	225	19
	Z3	325	325	225	19.4
	Z4	162.5	325	225	9.8

- FIRE RESISTANT TO EUROCLASS A1.

T: 01606 535300
F: 01606 75905
E: civils@andertonconcrete.co.uk
W: www.andertonconcrete.co.uk

Anderton
CONCRETE PRODUCTS LTD

KEYSTONE



Seafront, Southend-on-Sea

Keystone is a system of modular retaining wall units that are manufactured from high strength, durable concrete which are laid dry and can be used in conjunction with a geogrid to provide tall walls or to accommodate high surcharges.

Alternatively, it can be used with or without a concrete backing to create a gravity wall.

Keystone uses a unique high strength fixing system which securely locks the component parts in place. At the centre of the system is the patented blue comb connector that provides exceptionally high connection strengths.



Keystone block showing grid connection

A combination of Keystone modular units, positive pin connections and soil reinforcing geogrids delivers 'rock solid' stability and performance – its enhanced connection between grid and block is critical to ensure economic designs.

DESIGN

Keystone is available on a design and supply basis. Our engineers have a wealth of knowledge and expertise in the field of Geotechnology. Wherever possible we aim to work with clients from the outset, in order to offer them the most cost-effective design solutions possible.

This system has the British Board of Agrément approval. This Certificate contains all respective design and construction information.



Passenger access, Littleborough Station, Rochdale

APPLICATIONS

Keystone's ability to connect positively with proprietary geogrid systems has enabled it to be built to heights of over 15 metres worldwide – making it ideal for roadside and bridge locations and its simple, dry build construction enables it to handle the most challenging site design.

KEYSTONE'S VERSATILITY IS IDEAL FOR:

- Retaining Walls
- Embankments
- Culverts
- Bridge Abutments
- Tunnel Entrances
- Access Ramps
- River Diversions / Flood Alleviation Schemes

AESTHETIC IMPACT

Keystone provides design flexibility to meet the unique challenges of modern commercial development projects; whether you are building tall retaining walls, short walls, using curves or corners, considering rapid changes in elevation detail or using Keystone with other specialist materials. This proven system enhances the architectural importance of any structure whether new-build or refurbishment.

A Keystone retaining wall offers a positive solution to the most challenging and demanding design and construction requirements.

This inner strength is complemented by the aesthetic impact of a system capable of combining classic lines, graceful curves, shadows and textures.



KEYSTONE

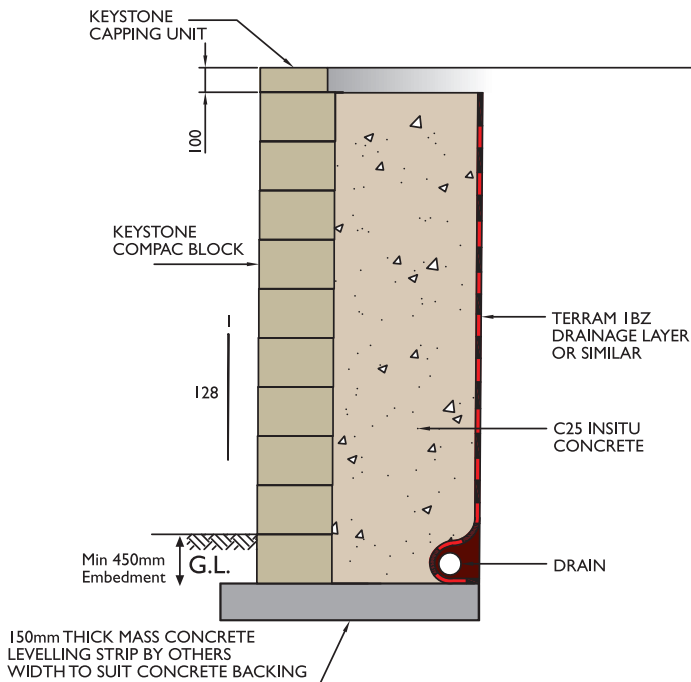

Keystone Compac vertical wall with concrete backing & 100mm Capping

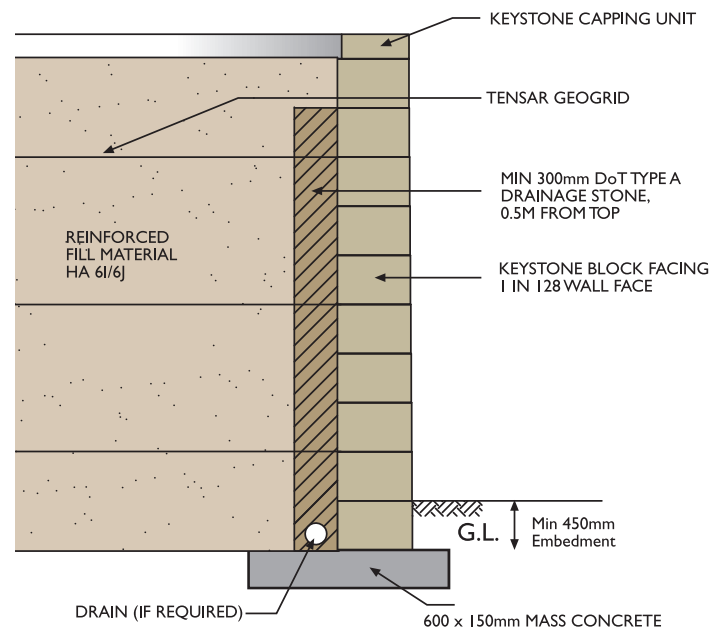

Keystone Compac with grid system retaining wall

EASY TO INSTALL

- Interlocked, mortar-free assembly**
 No mortar required, thus allowing free flow drainage through the wall, releasing hydrostatic loads.
- Patented fibreglass pin system**
 These ensure a proper alignment, unit interlock and the ability to create convex or concave curves.
- Rapid installation**
 A walling system that allows for faster construction – no mortar, simple foundations and straight-forward build.

ANCILLARY COMPONENTS

A choice of ancillary components are available to add the 'finishing touches' to walls and to solve on-site engineering problems.

DESIGN SERVICE

We have many years of experience developing our Keystone products and are able to offer exceptional levels of design and service support. We have an experienced technical support team and a very comprehensive design support programme to assist you with your individual requirements.

Creating gravity or unreinforced walls up to 2m high

Keystone can be used to create gravity or unreinforced wall up to 2m in height. For most applications, no structural foundation is required and a simple levelling pad will suffice. Even in the case of unreinforced soil walls – only the base course of facing units require bedding on mortar.

Creating reinforced soil walls

For taller and more critical walls, Keystone units are combined with soil reinforcement options to create larger composite structures. With this properly designed combination, the reinforced soil mass can support greater earth pressure and surcharge loads; and the pin/comb fixing concept allows geogrid material to be fully incorporated into the structure of the wall providing an exceptionally strong 'mechanical' link.



Split Face



Smooth Face



East London Line railway.

T: 01606 535300
F: 01606 75905
E: civils@andertonconcrete.co.uk
W: www.andertonconcrete.co.uk

Anderton
 CONCRETE PRODUCTS LTD

KEYSTONE

The Keystone system comprises of four units – **Compac, Corners, Caps and Slips.**

These units provide the ability to vary height and the opportunity to further explore the variations created by light and shadow by introducing band courses.

COMPAC

Keystone Compac is the perfect choice for either gravity or reinforced walls. It is available with a split or smooth finish.

Weight 39.5kg

Size (L x W x H)
455 x 300 x 200mm

Exposed face area 0.091m²

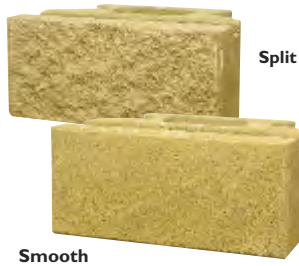

CAPS

Caps are available with a smooth top surface, and in split or smooth profiles.

Size (L x W x H)
455 x 267 x 100mm - 25.9kg
455 x 228 x 200mm - 43.5kg

Exposed face area 0.0457m² - (100mm)
0.091m² - (200mm)

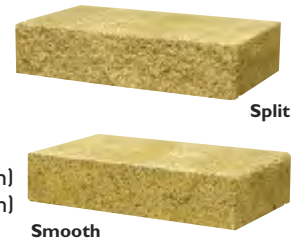

CORNER BLOCK

Keystone corner block is used to create 90 degree corners. It is available with a split or smooth finish.

Weight 43.6kg

Size (L x W x H)
455 x 228 x 200mm

Exposed face area 0.136m²

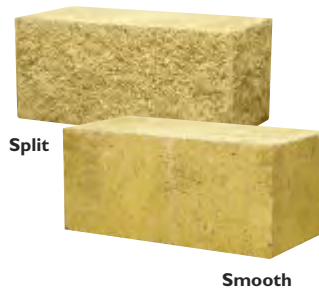

SLIPS

Slips are used to face concrete or piled structures to provide continuity of appearance. Split face finish only.

Weight 17.5kg

Size (L x W x H)
455 x 95 x 200mm

Exposed face area 0.091m²



Standard Colours



Flint



Yorkstone



Sandstone



Pewter



Ivory

Alternative Colours

The reproduction of colour is as close as is possible within the photographic and printed processes. Where precise colour tolerances are vital, you are advised to view actual product samples. Whenever practical, blocks should be mixed from more than one pack.

SLOPE-LOC

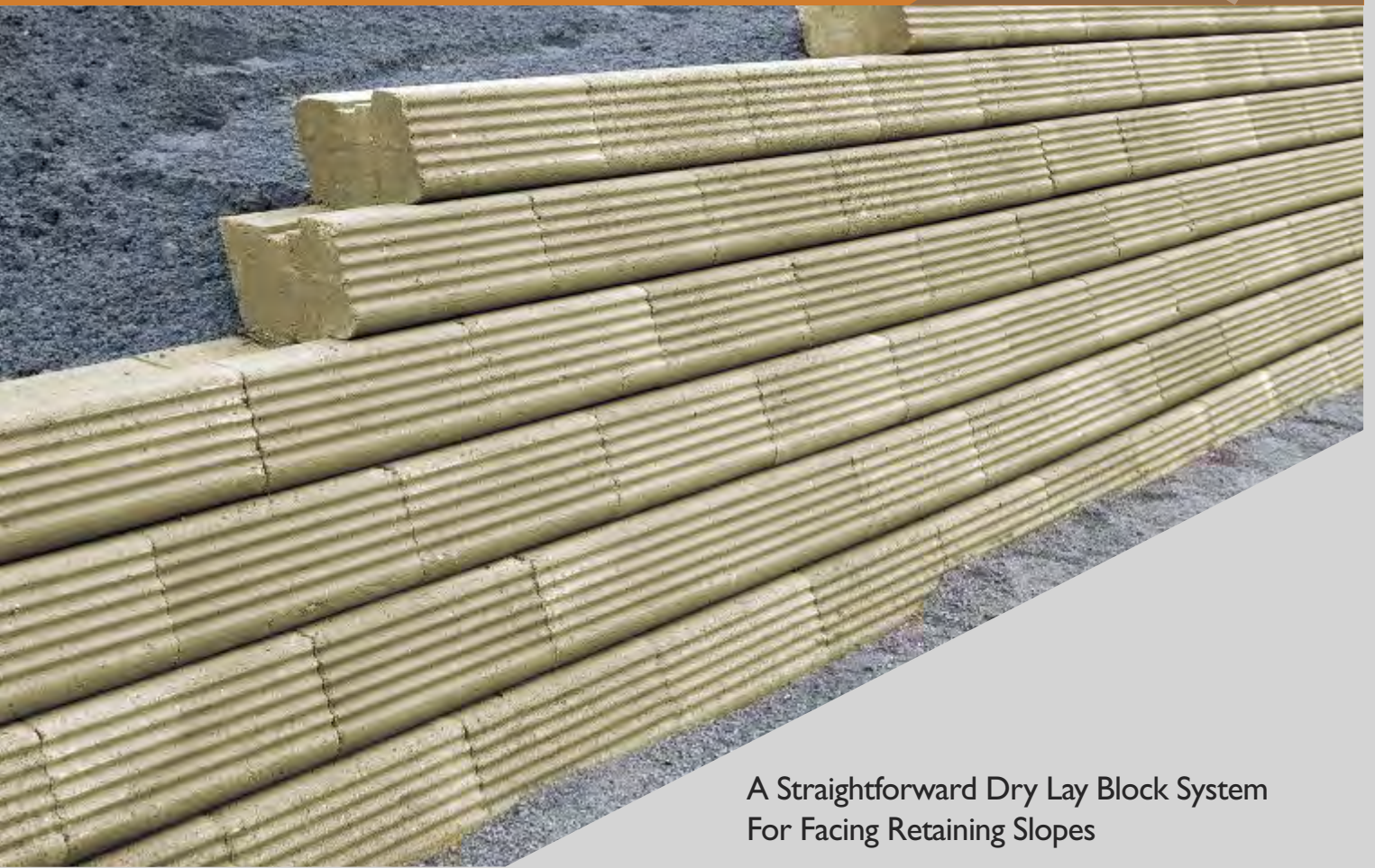

A Straightforward Dry Lay Block System For Facing Retaining Slopes

Slope-Loc can be used domestically in garden retaining wall projects or on a larger scale in commercial applications for embankment repairs and situations where an aesthetic slope is required.

SLOPE-LOC COLOURS



Flint



Yorkstone



Sandstone



Slope-Loc is ideal for aesthetic slopes and bankings

Available in three standard colours:

- Flint
- Yorkstone
- Sandstone

KEY BENEFITS:

- Unique economical alternative to vertical retaining walls
- Fully Professionally insured design
- All units less than 20kgs
- Proven block/grid connection
- Choice of colours - bespoke colours available to special order
- Fast, efficient delivery

T: 01606 535300
F: 01606 75905
E: civils@andertonconcrete.co.uk
W: www.andertonconcrete.co.uk

Anderton
CONCRETE PRODUCTS LTD

SLOPE-LOC

The **Slope-Loc** system comprises dry laid, ribbed face concrete blocks, in combination with a HDPE geogrid, secured with a patented blue connector, offering enhanced strength characteristics that ultimately provides the ability to design and construct taller walls that can support high loadings.



Build stage cross section showing geogrid and blue grid connector



Suitable for garden projects and large scale commercial applications

Specification

DIMENSIONS

(L x W x H) 300 x 245 x 125mm
Face area 0.0375m²

Typical Cross Section:

NOTES:

1. Wall shall be founded upon Competent Foundation Soils.
2. Slope-Loc walls have been designed based on a 5kPa Surcharge.
3. Well graded stone fill assumed with the following geo-technical properties $\text{PHI}'_{pk} = 36^\circ$, Bulk Density = 20kN/m³.

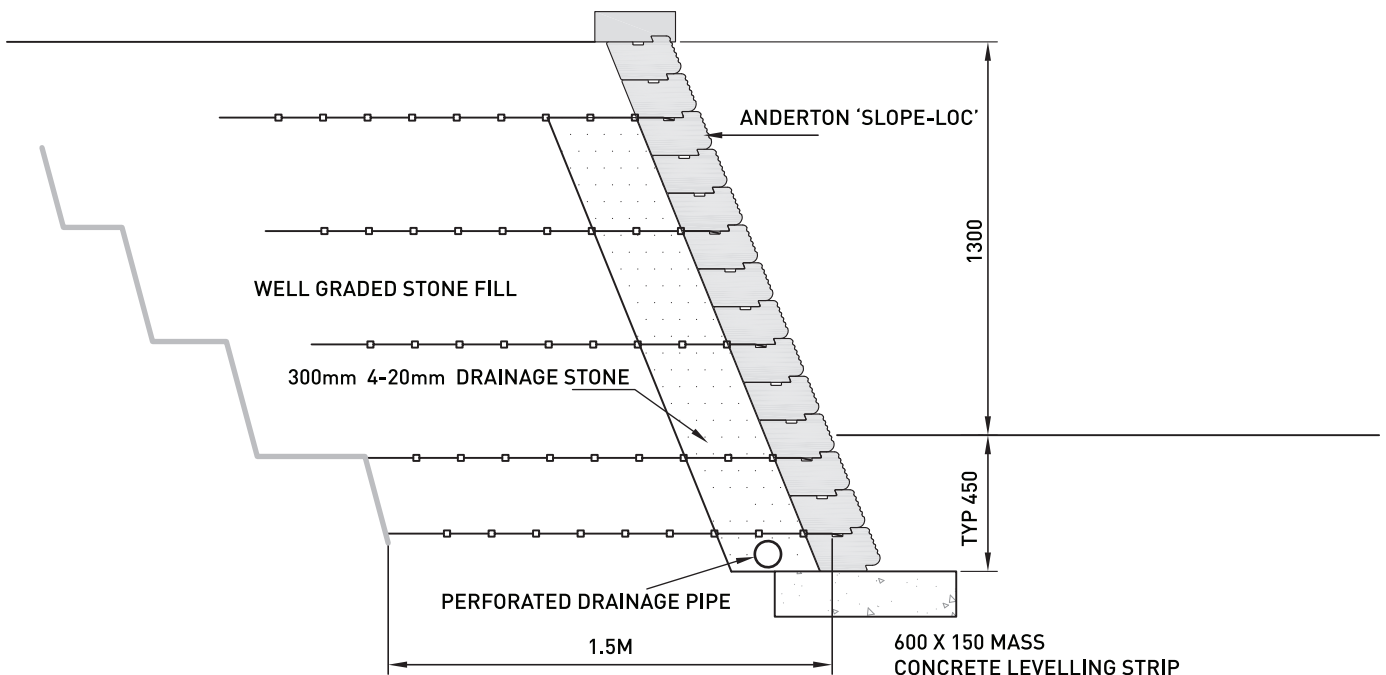



3

FENCING & BUILDING

OVERVIEW - FENCING & BUILDING

Anderton Concrete has a proven track record over many years of supplying precast concrete elements to the construction industry.



Anderton Precast, the choice for merchants and construction nationwide

Anderton Concrete specialises in providing precast concrete fencing and building solutions for all applications and our extensive product range is able to satisfy all builders merchants needs. The product range includes slotted fence posts, prestressed lintels and padstones, wall copings, pier caps, edgings, domestic inspection chambers, postmix and much, much more...

If you are looking for a company who always puts the customer first, for a company with national coverage and a company that is equally equipped to supply The Nationals, Buying Groups or the Independent Merchant then Anderton is the natural choice.

Manufactured to BS EN 12839

LITECAST FENCING PRODUCTS



Contracting



Do-It-Yourself



Health & Safety is a pre-requisite in today's society both commercially and domestically. The construction industry is certainly no exception and because of this, Anderton Concrete is in pole position in terms of research and development to alleviate these concerns wherever possible.

Anderton Concrete was the first company to market a slotted post and panel fencing system that offers:

- Significant weight reduction
- Strength and robustness
- Affordability

T: 01606 79436
F: 01606 871590
E: sales@andertonconcrete.co.uk
W: www.andertonconcrete.co.uk

Anderton
CONCRETE PRODUCTS LTD

LITECAST FENCING PRODUCTS



Anderton Litecast is The Future of Fencing

Why Choose Litecast?

- Makes light work of any fencing project
- User friendly
- Up to 45% lighter than traditional concrete
- Cost effective and easy to install
- Reduces site transport costs
- Steel reinforced
- Long lasting fencing solutions
- Speedier assembly
- Can be painted for a more rustic effect
- Makes lifting easier

Slotted Posts

Fence Height	Post Length	Approx kg	No. per pack
915	1370	16	36
1220	1750	19	36
1525	2055	22	36
1830	2360	25	36
2135	2665	28	36

Gravel Boards

Type	Dimensions	Approx kg	No. per pack	Manufacture
Recessed	1830 x 150 x 50	18	40	Semi / Dry
Recessed	1830 x 300 x 50	36	20	Semi / Dry

WET CAST SLOTTED POSTS



Anderton Concrete **Wet Cast Slotted Posts** provide a smooth surface finish in a strong and durable product range. Each post has the option of a different profile, with a pyramid at one end and a bobble top at the other.

Fence Height	Post Length	Width	Weight (kg)	Pack Size
915	1370	100x100	27	40
1220	1750	100x100	36	40
1525	2055	100x100	41	40
1830	2360	100x100	46	40
2135	2665	100x100	54	20
915	1370	125x100	36	24
1220	1750	125x100	45	24
1525	2055	125x100	50	24
1830	2360	125x100	57	24
2135	2665	125x100	64	24
2400	3000	125x100	72	12

Ends and Corner Posts available to suit

T: 01606 79436
 F: 01606 871590
 E: sales@andertonconcrete.co.uk
 W: www.andertonconcrete.co.uk

Anderton
 CONCRETE PRODUCTS LTD

SEMI-DRY SLOTTED POSTS



Anderton Concrete **Semi-Dry Slotted Posts** combine a rustic appearance with strength and robustness to provide a long lasting fencing solution. The high strength concrete post and gravel board is steel reinforced for extra stability. The Anderton Concrete semi-dry post unlike the timber alternative is completely unaffected from attack by moisture. Anderton Concrete semi-dry slotted posts provide a high strength product.

Fence Height	Post Length	Width	Weight (kg)	Pack Size
915	1525	100x100	26	36
1220	1830	100x100	32	36
1525	2130	100x100	38	36
1830	2440	100x100	46	36
2135	2740	100x100	52	36

Ends and Corner Posts available to suit

GRAVEL BOARDS

Using the Anderton Concrete range of slotted posts is an ideal way to produce high quality fencing and these, together with our wide selection of **gravel boards** offer strength, value and cost effectiveness.

Anderton Concrete gravel boards prevent timber from coming into contact with the ground thus preventing rot and decay. Anderton Concrete gravel boards are available in various sizes in both 'wet cast' and 'semi-dry' finish. We offer a complete range of styles including plain, recessed and rock-faced.



PLAIN BASE PANEL



RECESSED BASE PANEL



ROCK FACE BASE PANEL

Panel Type	Dimensions	Type of Manufacture	kg	Pack Size
Plain	1830x300x50mm	Wetcast	60	20
Plain	1830x300x40mm	Wetcast	48	20
Plain	1830x150x50mm	Wetcast	33	40
Recessed	1830x150x50mm	Semi-Dry	24	40
Recessed	1830x300x50mm	Semi-Dry	47	20
Rock face	1830x300x50mm	Wetcast	56	15

Gravel Boards for use with Recessed & Morticed Posts

Panel Type	Dimensions	Type of Manufacture	kg	Pack Size
Morticed/Recessed	2700x150x50mm	Semi-Dry	49	20
Morticed/Recessed	2885x150x50mm	Semi-Dry	52	20
Morticed/Recessed	3000x150x50mm	Semi-Dry	53	20

T: 01606 79436
 F: 01606 871590
 E: sales@andertonconcrete.co.uk
 W: www.andertonconcrete.co.uk

Anderton
 CONCRETE PRODUCTS LTD

CLOSEBOARD FENCING



Closeboard Fencing

A long lasting, durable and decorative solution for panel fencing. Anderton Concrete manufactures recessed and morticed fence posts using a 'semi-dry' high strength mix... designed to last!

Cost effective in purchase and installation and used in conjunction with the Anderton Concrete range of gravel boards these products are instrumental in reducing wood rot and decay.



MORTICED POST

Heavy Duty Section

Fence Height	Post Length	Post Section	Weight kg	Pack Size
1050	1750	140x115mm	68	18
1200	1900	140x115mm	72	18
1400*	2050	140x115mm	80	18
1500	2350	140x115mm	89	18
1650	2500	140x115mm	97	18
1800	2650	140x115mm	101	18
2400*	3250	140x115mm	127	18

Reduced Section

Fence Height	Post Length	Post Section	Weight kg	Pack Size
1500	1800	100x90mm	39	36
1800	2100	100x90mm	45	36
2100	2400	100x90mm	53	36

RECESSED POST

Heavy Duty Section

Fence Height	Post Length	Post Section	Weight kg	Pack Size
900*	1350	140x115> 100x115mm	44	25
1050	1600	140x115> 100x115mm	53	25
1200	1750	140x115> 100x115mm	58	25
1400*	1900	140x115> 100x115mm	62	25
1500	2200	140x115> 100x115mm	72	25
1650	2350	140x115> 100x115mm	77	25
1800	2500	140x115> 100x115mm	82	25
2000*	2700	140x115> 100x115mm	90	25

Reduced Section

Fence Height	Post Length	Post Section	Weight kg	Pack Size
900	1200	125x115> 125x100mm	47	25
1200	1500	125x115> 125x100mm	59	25
1500	1800	125x115> 125x100mm	67	25

*Not included in BS.

UNIVERSAL & HOLED POSTS

Universal & Holed Posts

Manufactured using a high strength 'semi-dry' mix, Anderton's universal and holed posts are the ideal solution for timber rail and wire fencing. Specified throughout the UK these posts are available in a variety of sizes.



ROUND TOP



UNIVERSAL POSTS

Holes - 12mm
Hole Centres - 75mm from the top then every 150mm.

BACK-WEATHERED TOP



BACK-WEATHERED BOTTOM

HOLED POSTS

Holes - 12mm
See table below for hole centres

UNIVERSAL POSTS

Fence Height	Post Height	Post Section	Weight (kg)	Pack Size
900	1500	100x100	35	30
1200	1800	100x100	43	30
1500	2100	100x100	50	30
1800	2400	100x100	57	30
2100	2700	100x100	64	30

HOLED POSTS

Fence Height	Post Height	Post Section	Hole Centres	Weight (kg)	Pack Size
900	1500	100x100	150/600	37	30
1200	1800	100x100	150/450/450	45	30
1500	2100	100x100	150/600/600	52	30
1800	2400	100x100	150/750/750	57	30
2100	2700	100x100	150/900/900	64	30

T: 01606 79436
F: 01606 871590
E: sales@andertonconcrete.co.uk
W: www.andertonconcrete.co.uk

Anderton
CONCRETE PRODUCTS LTD

REPAIR SPURS

Repair/Support Posts

For a cost effective, simple way of replacing rotting timber posts we hold a comprehensive stock of repair spurs manufactured from a high strength 'semi-dry' mix.

For all conditions, they are quick and easy to install.



REPAIR SPUR

REPAIR SPURS

Post Length	Post Section	Hole Centres	kg	Pack Size
1000mm	75x75	75/300	13	20
1050mm	100x75	75/300	19	36
1200mm	100x75	75/450	21	36
1200mm	100x100	75/450	28	30

CHAINLINK POSTS

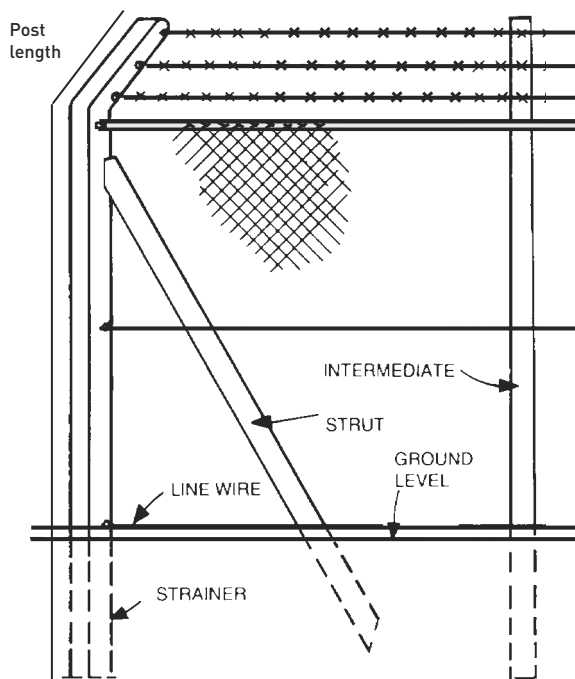

Chainlink Posts

Concrete posts used in conjunction with chainlink or wire mesh provide the optimum security solution, a tried and tested method for protecting sensitive installations. It is by far, the most cost-effective method of securing the perimeters of all types of premises.

STANDARD CHAINLINK POSTS

INTERMEDIATE

Chainlink Height	Post Length	Post Width	Weight kg
900mm	1600	125x125>75x75	39
1200mm	1870	125x125>75x75	44
1800mm	2460	125x125>75x75	58

STRAINER

Post Length	Post Width	Weight kg
1600	125x125	61
1870	125x125	69
2460	125x125	91

STRUT

Post Length	Post Width	Weight kg
1500	100x75	27
1830	100x75	34
2440	100x85	49

CHAINLINK POSTS WITH CRANKED EXTENSIONS

INTERMEDIATE

Chainlink Height	Post Length	Post Width	Weight kg
1800mm	3040	125x125>75x75	72

STRAINER

Post Length	Post Width	Weight kg
3040	125x125	113

STRUT

Post Length	Post Width	Weight kg
2590	100x85	52

T: 01606 79436
 F: 01606 871590
 E: sales@andertonconcrete.co.uk
 W: www.andertonconcrete.co.uk

Anderton
 CONCRETE PRODUCTS LTD

STRAINED WIRE POSTS



Strained Wire Posts

Manufactured using a high strength 'semi-dry' mix. Anderton Concrete **strained wire posts** provide the most cost-effective boundary/perimeter solution.

INTERMEDIATES

Post Length	Post Width	Weight kg
1720	100x100>75x75	31
1870	125x125>75x75	44
2020	125x125>75x75	48

STRAINER (2 ways, corner, ends)

Post Length	Post Width	Weight kg
1870	125x125	69
2020	125x125	75
2170	125x125	80

HOLE CENTRES

75/330/330
75/250/250 230/150/150
75/250/250 230/150/150/150

STRUT (flat)

Post Length	Post Width	Weight kg
1675	100x75	32
1830	100x75	34
1980	100x75	35

FAST-SET POST MIX



ANDERTON POST MIX is suitable for fixing all types of concrete, wooden, plastic and metal posts, signage and bollards.

The product is ready for immediate use. No mixing required.

- fast setting, high strength
- pre-mixed concrete
- just add water
- easy to handle 20kg bags
- 70 bags per pallet
- ideal for fixing fence posts and bollards

Instructions for use

1. Dig a hole to suitable depth: As a guide a 2.4m post should have approximately 0.6m below ground.
2. Position post in the hole and check for alignment with a spirit level.
3. Pour half the Anderton Post Mix into the hole around the post and add clean water: Approx 2.0 litres dependent on ground conditions.
4. After a couple of minutes re-check the post alignment.
5. Pour the remaining Anderton Post Mix into the hole and add clean water: Approx 2.0 litres dependent on ground conditions.
6. Allow 10 to 15 minutes depending on temperature and humidity.
7. Leave at least 1 hour before fixing anything to the post.
8. Anderton Post Mix should not be used if the ground is frozen or if temperature is below 5°C.
9. Quantity of Anderton Post Mix required will vary upon local ground conditions, size of hole and post etc but for most fence posts two 20kg bags will be sufficient.
10. Stored under dry conditions, an unopened bag of Anderton Post Mix will have a usable life of 6 months.

Health & Safety Information

- Personal protective equipment must be worn at all times when handling this product.
- Avoid contact with exposed skin.
- Care must be taken to avoid injury or strain when lifting bags.
- A full Health & Safety Datasheet is available on request.

T: 01606 79436
F: 01606 871590
E: sales@andertonconcrete.co.uk
W: www.andertonconcrete.co.uk

Anderton
CONCRETE PRODUCTS LTD

LINTELS & PADSTONES

Anderton Concrete pre-stressed **lintels** are manufactured to EN 845-2. With stock available in a variety of sizes, we can cater for all your building requirements at short notice.



Anderton Concrete Lintels

- The most economical lintels available
- Quality controlled manufacturing
- A comprehensive range for load bearing capacity
- Ease of installation ensuring construction continuity
- Robust
- Easy to transport



LINTEL

Pack Size	21	36	36	30	Section	Section	Section
	Section	Section	Section	Section	225 x 65mm	225 x 100mm	215 x 140mm
	100 x 65mm	150 x 65mm	250 x 65mm	150 x 100mm	kg	kg	kg
Lintel Length	kg	kg	kg	kg	kg	kg	kg
600	8.6	11.6	23	18.6	19.4	27.4	38.4
750	10.8	14.5	29.2	23.3	24.3	34.3	48
900	12.9	17.4	34.8	27.9	29.1	41.1	58
1050	15.1	20.3	41.8	32.6	34	48	67
1200	17.2	23.2	46.5	37.2	38.8	54.8	77
1350	19.4	26.1	53.5	41.9	43.7	61.7	86
1500	21.5	29	58.1	46.5	48.5	68.5	96
1800	25.8	34.8	69.7	55.8	58.2	82.2	115
2100	30.1	40.6	81.4	65.1	67.9	95.9	134
2400	34.4	46.4	93	74.4	77.6	110	153
2700	38.7	52.2	104.6	83.7	87.3	123.3	173
3000				93	97	137	192

For further details of our non-standard lintels please contact our sales office.

Anderton Concrete Padstones



PADSTONE

The preferred way to install your lintel is to seat it on an Anderton Padstone. A comprehensive range of Padstones are available in a wide range of sizes and again... all ex-stock!

Bespoke Padstones and Lintels can be made to customer's exact specifications. Please contact our Sales Department for further help and advice.

Size	Weight	Size	Weight
215 x 140 x 100 mm	7 kg	440 x 215 x 140 mm	32 kg
300 x 140 x 100 mm	11 kg	440 x 215 x 215 mm	49 kg
440 x 140 x 100 mm	15 kg	215 x 215 x 100 mm	11 kg
330 x 215 x 100 mm	17 kg	215 x 215 x 140 mm	16 kg
440 x 215 x 100 mm	23 kg		

RECTANGULAR INSPECTION CHAMBERS

Anderton Concrete **Rectangular Inspection Chambers** are manufactured in high strength concrete, using the latest in machinery and technology. All these products are produced under strict factory controlled conditions.

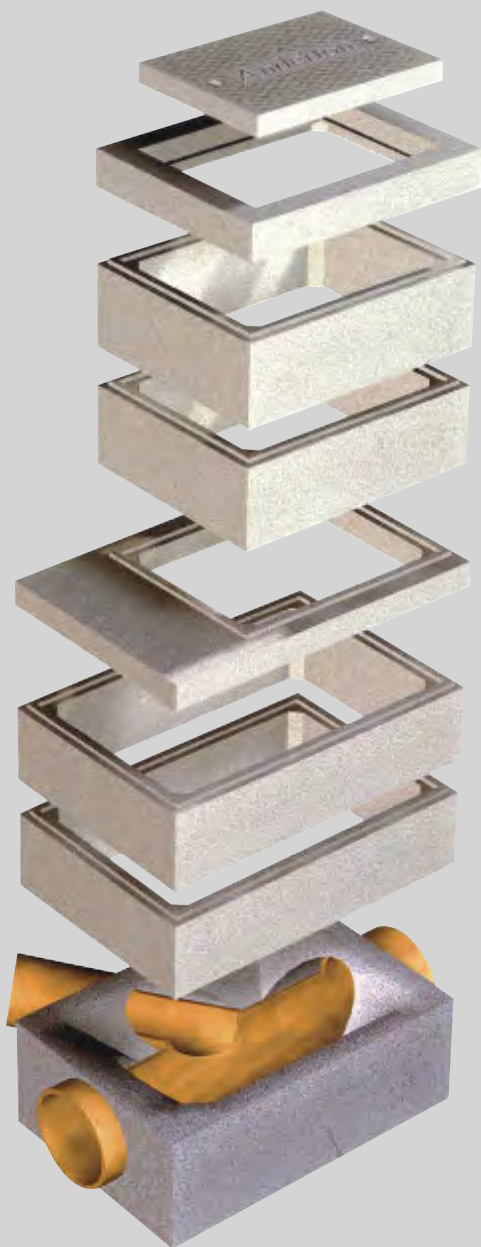

Here are just some of the benefits:

Tongue and Groove Joint Detail

Allows easy placement and is suitable to receive a recommended sealant or a bedding mortar.

Can be used on Depths of up to 2.7m

The vast range of sizes makes it suitable for most domestic inspection chamber requirements.

Manufactured to EN 1917

Another high quality Anderton Concrete product... built to last.

T: 01606 79436
F: 01606 871590
E: sales@andertonconcrete.co.uk
W: www.andertonconcrete.co.uk

Anderton
CONCRETE PRODUCTS LTD

CHAMBER SECTIONS & REDUCERS / COVER SLABS



CHAMBER SECTIONS

Chamber Sections

Plan Sizes	Depth	Wall Thickness	Weight kg	Max. Depth to Insert	Pack Size
450 x 600	150	50	46	1000	14
	225	50	68	1000	10
	300	50	95	1000	8
750 x 600	150	60	68	1000	7
	225	60	103	1000	5
	300	60	121	1000	4
1000 x 675	150	65	88	1000	7
	225	65	132	1000	5
	300	65	158	1000	4
1200 x 750	150	75	106	2700	7



REDUCERS / COVER SLABS

Reducers / Cover Slabs

Reduce From	Reduce to	Depth	Access	Weight kg	Pack Size
1000 x 675	750 x 600	65	Offset	69	5
1000 x 675	450 x 600	65	Offset	95	5
750 x 600	450 x 600	100	Centre	64	5

Cover Slabs

1200 x 750	600 x 600	90	Offset	172	2
1200 x 750	600 x 600	140	Offset	282	2

FRAMES & COVERS



FRAMES



COVERS

Frames & Covers to suit 450 x 600 Chamber Sections

	External Size	Access Hole	Depth to Ledge	Weight kg	Pack Size
Frame	800 x 650 x 100	450 x 600	45	48	10
Cover	695 x 545 x 45			43	20

Frames & Covers to suit 750 x 600 Chamber Sections

	External Size	Access Hole	Depth to Ledge	Weight kg	Pack Size
Frame	870 x 720 x 95	450 x 600	45	64	10
Cover	710 x 560 x 45			46	20

Concrete frames and covers are for pedestrian traffic only.

T: 01606 79436
 F: 01606 871590
 E: sales@andertonconcrete.co.uk
 W: www.andertonconcrete.co.uk

Anderton
 CONCRETE PRODUCTS LTD

WALL COPINGS

The final touch to your decorative wall can be achieved by using the Anderton Concrete range of quality **copings**. Available in a variety of sizes, the smooth cast finish offers an attractive conclusion to any project.



TWICE WEATHERED COPING



Twice Weathered Copings

Size	Corners	Weight	Pitch	Pack Size
600 x 138	✓	6.7 kg	30/45	64
600 x 175		8.9 kg	30/45	48
600 x 225		12.0 kg	30/45	40
600 x 275	✓	14.6 kg	30/45	40
600 x 300	✓	25.0 kg	50/75	32
900 x 300		37.8 kg	50/75	24
600 x 350		31.0 kg	50/75	24
900 x 400		53.0 kg	50/75	15
900 x 450		60.0kg	50/75	10



ONCE WEATHERED COPING

Once Weathered Copings

Size	Weight	Pitch	Pack Size
600 x 165	8.0 kg	40/60	48
600 x 220	11.0 kg	40/60	40
600 x 300	25.0 kg	50/75	32
900 x 300	37.8 kg	50/75	20
600 x 350	31.5 kg	50/75	24
900 x 400	50.0 kg	50/75	15
900 x 450	63.0 kg	50/75	10

Flat Coping

Size	Weight	Pitch	Pack Size
600 x 300	22.0 kg	50	24

PIER CAPS

The final touch to your decorative pillar wall can be achieved by using the Anderton Concrete range of quality **pier caps**. Available in a variety of sizes, the smooth cast finish offers an attractive conclusion to any project.

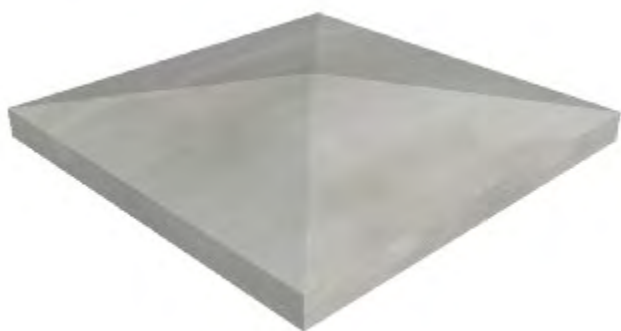

PIER CAP

Pier Caps

Size	Weight	Pitch	Pack Size
225 x 225	6.3 kg	40/80	24
300 x 300	10.7 kg	40/80	24
375 x 375	22.6 kg	40/80	12
400 x 400	26.0 kg	40/80	15
450 x 450	33.0 kg	40/80	12
525 x 525	43.0 kg	45/90	6
600 x 600	57.6 kg	60/120	4

T: 01606 79436
F: 01606 871590
E: sales@andertonconcrete.co.uk
W: www.andertonconcrete.co.uk

Anderton
CONCRETE PRODUCTS LTD

ANCILLARY BUILDING PRODUCTS

Edgings

Manufactured to harmonised standard EN 1340

The perfect way to create a durable, and strong edge restraint.

Anderton Concrete edging is available both flat top and round top with a smooth cast finish to complement any external decorative project.



PATH EDGING FLAT TOP



PATH EDGING ROUND TOP



BOLLARD

Bollards

If you require a physical barrier in respect of vehicular access, you should always consider Anderton Concrete Bollards.



SILL



ANDER-TURF



GULLY SURROUNDS

Sills

Precast concrete sills are used below windows to provide support and help protect the masonry.

Ander-Turf

Ander-Turf is the environmentally friendly solution to provide parking areas with a more aesthetically pleasing approach.

The grass grid system supplied by Anderton Concrete utilises the latest manufacturing techniques and is a strong and durable alternative to traditional parking area construction.

Gully Surrounds

Anderton Concrete gully surrounds prevent splash back to surrounding paved areas from down-pipe discharges. They also help to prevent unwanted debris entering a drainage system, reducing the likelihood of blocking.

EDGINGS

	Size	Weight	Pack Size
Flat Top	900 x 150	15.0 kg	76
Round Top	900 x 150	15.0 kg	76
Round Top	900 x 200	21.0 kg	36

BOLLARDS

Size	Weight	Pack Size
1050 x 225 (Reducing to 150)	72.0 kg	7
1370 x 225 (Reducing to 150)	91.0 kg	7

SILLS

Size	Weight	Pitch	Pack Size
1065 x 225	31 kg	50/60	15
1220 x 225	36.6 kg	50/60	15
1525 x 225	45.6 kg	50/60	15
1830 x 225	53.0 kg	50/60	15

ANDER-TURF

Size	Weight	Pack Size
400x600x100	34.0kg	24

GULLY SURROUNDS

Size	Weight	Pack Size
225x225x150	16.0kg	30
450x225x150	22.0kg	25

4

RAILWAY PRODUCTS

OVERVIEW - RAILWAY PRODUCTS

Anderton Concrete is the market leader in the supply of cable protection products to the UK rail industry.



Anderton Concrete manufactures the full C/1 range of troughing products including Tee Pieces, Transitions and Curves, designed to comply with Network Rail standards and as such, has full Network Rail Approval status, Certificate No. PA05/00318 and Link-Up accreditation.

Anderton Concrete offers the widest range of complimentary precast products into the UK Rail Industry, including Drainage Catchpits, Signal Bases, Point Rod Rollers, Ballast Boards, Posts, Postmix and much, much more, all used extensively throughout the rail infrastructure.

Anderton Concrete holds significantly high levels of stock and is allied to a nationwide distribution network ensuring fast, on time deliveries.

Based on a solid reputation for delivering quality products and providing a first class service, Anderton Concrete is committed to continued product and process development ensuring that all customers receive complete satisfaction.

Anderton Concrete is the natural choice for the contractor.

- Approved Supplier to Network Rail
- Member of the Rail Alliance
- Registered Supplier to Link-up



ANDERLITE™ TROUGHING

UP TO 30% WEIGHT REDUCTION OVER TRADITIONAL ROUTE SYSTEMS

The **Anderlite Troughing System** is a lightweight cable route system which combines the strengths and benefits of traditional methods, plus a reduction in weight of up to 30%. This lightweight advantage is both user friendly and cost effective.



The Anderlite range of products have an identical profile to the current C/1 troughing range, thus a transition from system to system is seamless and requires no alteration to traditional lineside infrastructure equipment or practices.

The Anderlite Cable Route Troughing System is the most cost effective lightweight system to procure in the UK, and is up to 50% cheaper than alternative lightweight systems currently on the market. Once procured the Anderlite System provides savings in on-site labour costs and offers a speedier installation process.

Anderlite reduces the risk of manual handling concerns and minimises labour requirements. Also the general reduction in the weight of the product reduces transport costs by up to 20%, lessening the carbon footprint for all industry partners and providing cost savings over traditional systems. The unique cementitious mix design utilises up to 45% of recycled materials which reduces the environmental impact of the product.

The Advantages of Anderlite Troughing

Network Rail Approved	✓	Compatible with existing systems	✓
Environmentally friendly	✓	Complete range of C/I sizes	✓
Up to 30% lighter than traditional systems	✓	Unique mix design	✓
Reduces manual handling concerns	✓	Reduces transport costs by up to 20%	✓
Cementitious based	✓	Optional cable theft deterrent system	✓
Cost effective in purchase	✓	Fire resistant	✓
Cost effective in installation	✓	Weather resistant	✓
Tried and tested	✓	Sulphur resistant	✓
Strong, robust, durable	✓	Anti-static	✓
Long lasting stable installation	✓	Whole life costing solution	✓

ANDERLITE™ TROUGHING

Anderlite retains sufficient mass to ensure that once lineside it provides a stable installation that is free from future movement, 'snaking' or disruption brought about from train movement, severe weather conditions or ground movement.

The system also offers the optional benefit of being able to protect cables against theft when used in conjunction with the Anderton Route Security System.

Other inherent qualities of the Anderlite system are its resistance from sulphur attack in certain ground conditions and its excellent resistance qualities against fire and weather. It is also anti-static whilst having no detrimental impact on other lineside infrastructure equipment.



REDUCES TRANSPORTATION COSTS BY UP TO 20%

ANDERLITE TROUGH

Product Description	Part Number	BRB Cat/No	Internal Dimensions		External Dimensions		Approx Weight (kg)	Pack Size
			Width	Depth	Width	Depth		
C.1.6 Trough	C/1/6TRW	4/131417	100	90	190	130	24	36
C.1.7 Trough	C/1/7TRW	4/131419	130	130	220	170	32	30
C.1.8 Trough	C/1/8TRW	4/131421	150	200	250	240	46	15
C.1.9 Trough	C/1/9TRW	4/131423	190	130	280	170	36	24
C.1.10 Trough	C/1/10TRW	4/131425	250	130	340	170	40	18
C.1.29 Trough	C/1/29TRW	4/131427	350	130	440	170	46	14
C.1.43 Trough	C/1/43TRW	4/131428	350	300	440	340	75	9

ANDERLITE LID

Product Description	Part Number	BRB Cat/No	Internal Dimensions of Trough		External Dimensions of Lid		Approx Weight (kg)	Pack Size
			Width	Depth	Length	Width		
C.1.6 Lid	C/1/6LRW	4/131418	100	90	1000	190	14	60
C.1.7 Lid	C/1/7LRW	4/131420	130	130	1000	220	18	50
C.1.8 Lid	C/1/8LRW	4/131422	150	200	1000	250	19	50
C.1.9 Lid	C/1/9LRW	4/131424	190	130	1000	280	22	48
C.1.10 Lid	C/1/10LRW	4/131426	250	130	1000	340	26	36
C.1.29 Lid	C/1/29LRW	4/131429	350	130	1000	440	43	24
C.1.43 Lid	C/1/29LRW	4/131429	350	300	1000	440	43	24



- Please note once the lid is fitted the internal capacity of the trough will be reduced.

NETWORK RAIL APPROVED

ANDERTON INTERLOC™



ANDERTON INTERLOC is designed to prevent the unauthorised removal of trough lids, thus safeguarding all standard power and telecommunication systems.

Each adjoining lid is inter-locked by two **ANDERTON INTERLOC BRACKETS**, thus utilising the weight of each unit, making vertical uplift virtually impossible.

For additional security the **ANDERTON INTERLOC BRACKET** is equipped with a tensile clip which, when fastened secures each lid to each trough, thus making the route totally secure.

When looking for a totally secure locking system **ANDERTON INTERLOC** is the natural choice for the contractor.

Patent applied for.

THE ANDERTON INTERLOC™ SYSTEM

- Secures run of lids to trough route
- Prevents vertical uplift
- Maximises internal trough capacity
- Easily fitted to existing troughing routes
- Rapid installation
- Cost effective in purchase
- Supplied in Bags of 20
- Interlocks each adjoining lid
- Prevents lateral movement
- No alteration to a standard lid
- Lightweight
- Ease of authorised access
- Cost effective in installation

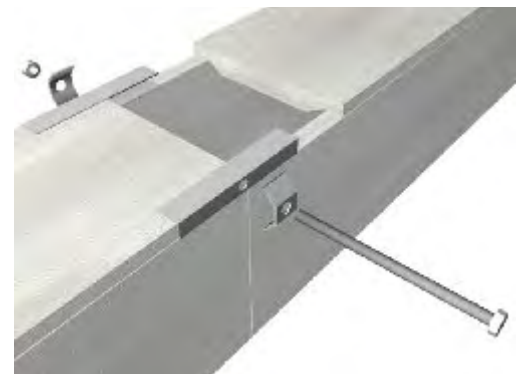

T: 01606 79436
F: 01606 871590
E: sales@andertonconcrete.co.uk
W: www.andertonconcrete.co.uk

Anderton
CONCRETE PRODUCTS LTD

TROUGH STRAIGHT

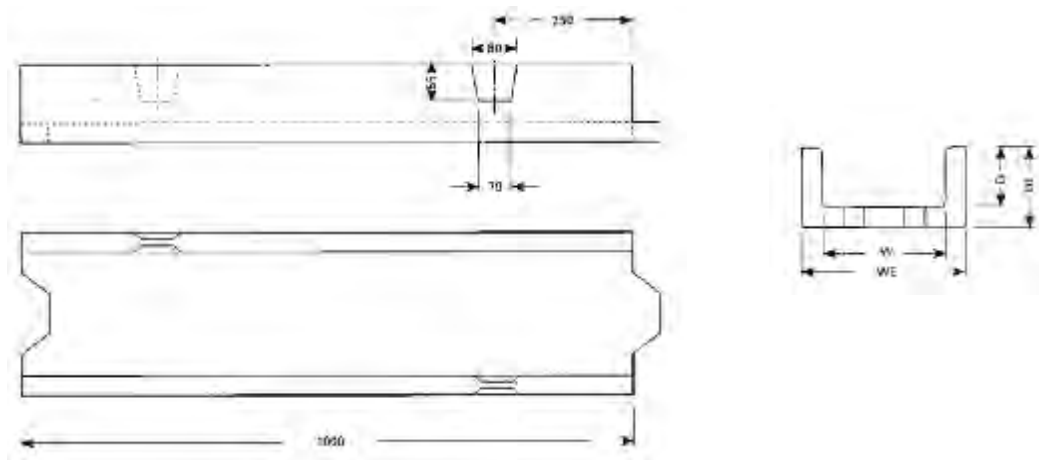

Product Description	BRB Cat/No	Size of Trough		Internal Dimensions		External Dimensions		Weight (kg)	Pack Size
		Width W	Depth D	Width WE	Depth DE				
C.1.6 Trough	4/105351	100	90	190	130	37	36		
C.1.7 Trough	4/105353	130	130	220	170	49	30		
C.1.8 Trough	4/105355	150	200	250	240	71	15		
C.1.9 Trough	4/105357	190	130	280	170	54	24		
C.1.10 Trough	4/105359	250	130	340	170	62	18		
C.1.29 Trough	4/105361	350	130	440	170	71	14		
C.1.43 Trough	4/105363	350	300	440	340	115	9		

- Standard Troughs and Lids are for pedestrian traffic only.
- Please note once the lid is fitted the internal capacity of the trough will be reduced.

LID STRAIGHT

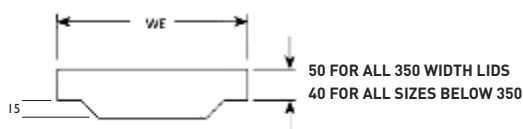
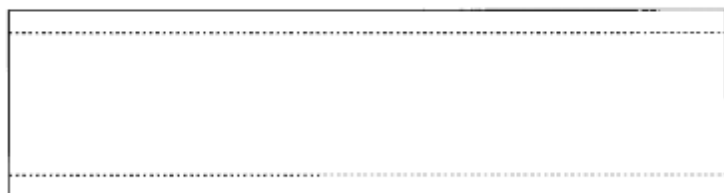
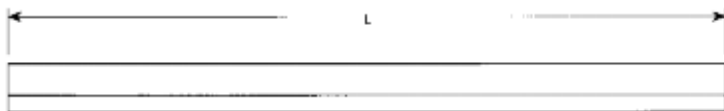

Product Description	BRB Cat/No	Size of trough Internal Dimensions	Lid External Length L	Dimensions Width WE	Weight (kg)	Pack Size
C.1.6 Lid	4/105282	100 x 90	1000	190	22	60
C.1.7 Lid	4/105285	130 x 130	1000	220	27	50
C.1.8 Lid	4/105288	150 x 200	1000	250	29	50
C.1.9 Lid	4/105291	190 x 130	1000	280	34	48
C. 1.10 Lid	4/105294	250 x 130	1000	340	42	36
C.1.29 Lid	4/105297	350 x 130	1000	440	66	24
C.1.43 Lid	4/105297	350 x 300	1000	440	66	24

- Standard Troughs and Lids are for pedestrian traffic only.
- Please note once the lid is fitted the internal capacity of the trough will be reduced.

T: 01606 79436
F: 01606 871590
E: sales@andertonconcrete.co.uk
W: www.andertonconcrete.co.uk

Anderton
CONCRETE PRODUCTS LTD

TROUGH TEE

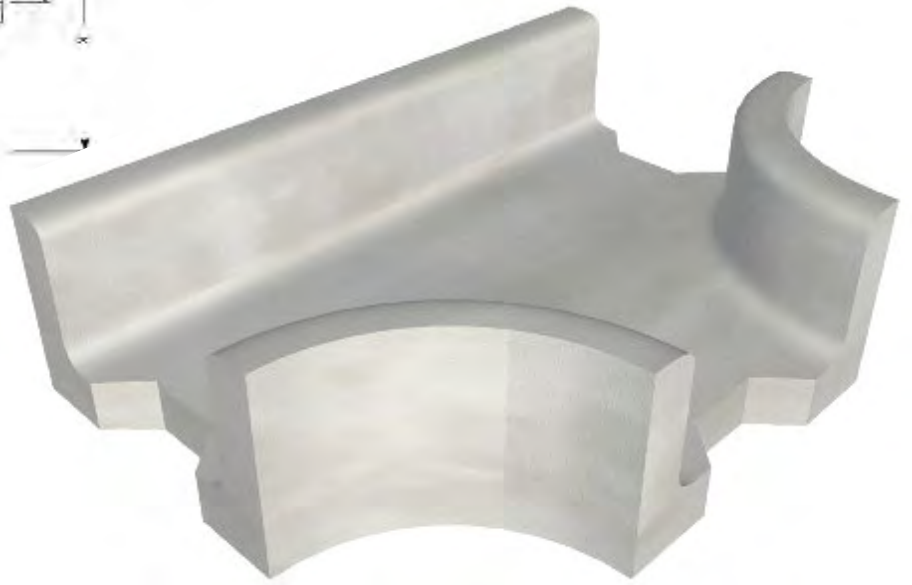
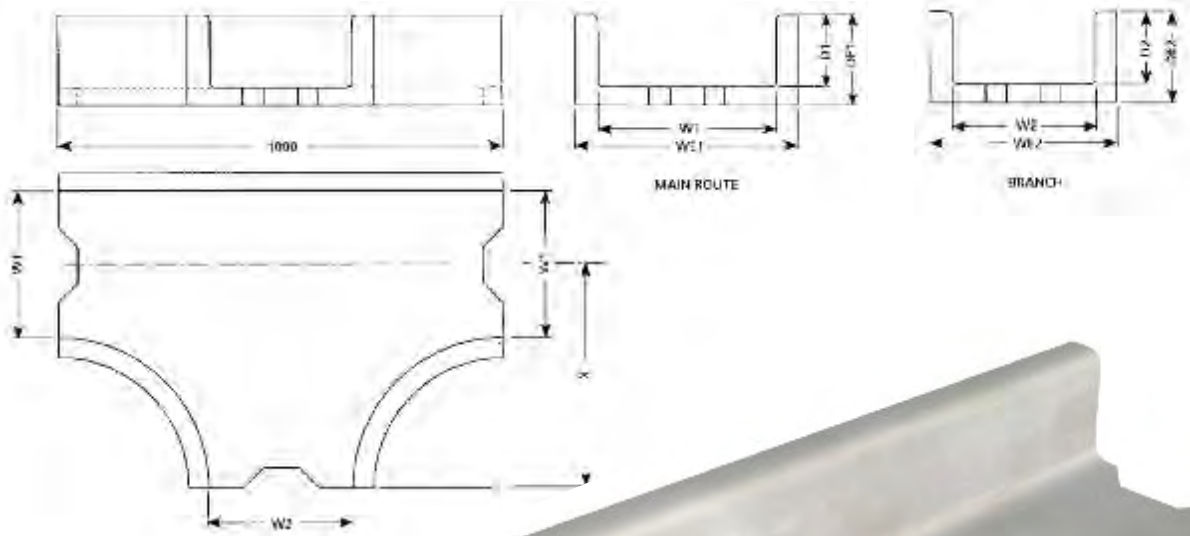

Product Description	To Suit	BRB Cat/No	Size of Tough				(x)	Weight (kg)	Pack Size
			Main Route		Branch				
			Width W1	Depth D1	Width W2	Depth D2			
C.1.41 Trough	C.1.6	4/105191	100	90	100	90	450	51	10
C.1.39 Trough	C.1.7	4/105195	130	130	130	130	450	70	10
C.1.23 Trough	C.1.8	4/105199	150	200	150	200	500	99	8
C.1.37 Trough	C.1.9	4/105207	190	130	190	130	450	68	10
C.1.34 Trough	C.1.10	4/105213	250	130	250	130	450	73	10
C.1.80 Trough	C.1.29	4/105216	350	130	350	130	450	83	10
C.1.81 Trough	C.1.43	4/105220	350	300	350	300	450	140	2
C.1.42 Trough	C.1.29 with C1.8 Branch	4/105217	350	130	150	200	450	77	8
C.1.32 Trough	C.1.29 with C1.10 Branch	4/105221	350	130	250	130	450	81	10

- Standard Troughs and Lids are for pedestrian traffic only.
- Please note once the lid is fitted the internal capacity of the trough will be reduced.

LID TEE

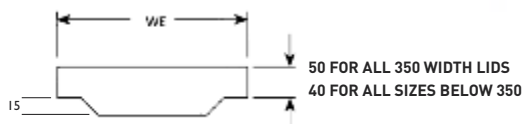
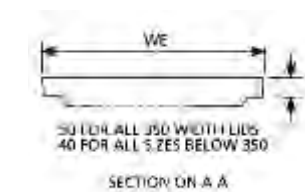
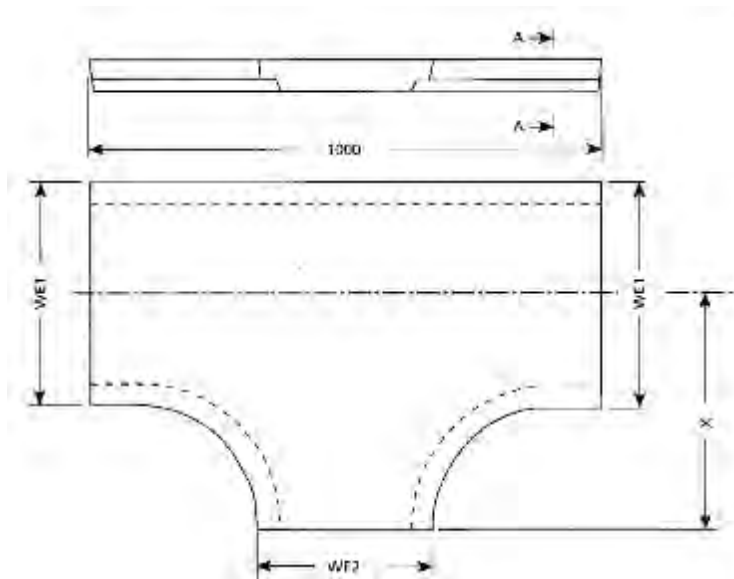

Product Description	To Suit	BRB Cat/No	Size of Trough		Width WE1	Width WE2	(x)	Weight (kg)	Pack Size
			Main route Internal Dimensions	Branch Internal dimensions					
C.1.41 Lid	C.1.6	4/105315	100 x 90	100 x 90	190	190	450	39	20
C.1.39 Lid	C.1.7	4/105314	130 x 130	130 x 130	220	220	450	43	20
C.1.23 Lid	C.1.8	4/105317	150 x 200	150 x 200	250	250	500	54	16
C.1.37 Lid	C.1.9	4/105313	190 x 130	190 x 130	280	280	450	52	20
C.1.34 Lid	C.1.10	4/105312	250 x 130	250 x 130	340	340	450	60	20
C.1.80 Lid	C.1.29	4/105318	350 x 130	350 x 130	440	440	450	77	20
C.1.81 Lid	C.1.43	4/105318	350 x 300	350 x 300	440	440	450	77	20
C.1.42 Lid	C.1.29 with C.1.8 Branch	4/105316	350 x 130	150 x 200	440	250	450	33	16
C.1.32 Lid	C.1.29 with C.1.10 Branch	4/105311	350 x 130	250 x 130	440	340	450	88	20

- Standard Troughs and Lids are for pedestrian traffic only.
- Please note once the lid is fitted the internal capacity of the trough will be reduced.

T: 01606 79436
 F: 01606 871590
 E: sales@andertonconcrete.co.uk
 W: www.andertonconcrete.co.uk

Anderton
 CONCRETE PRODUCTS LTD

TROUGH CURVED

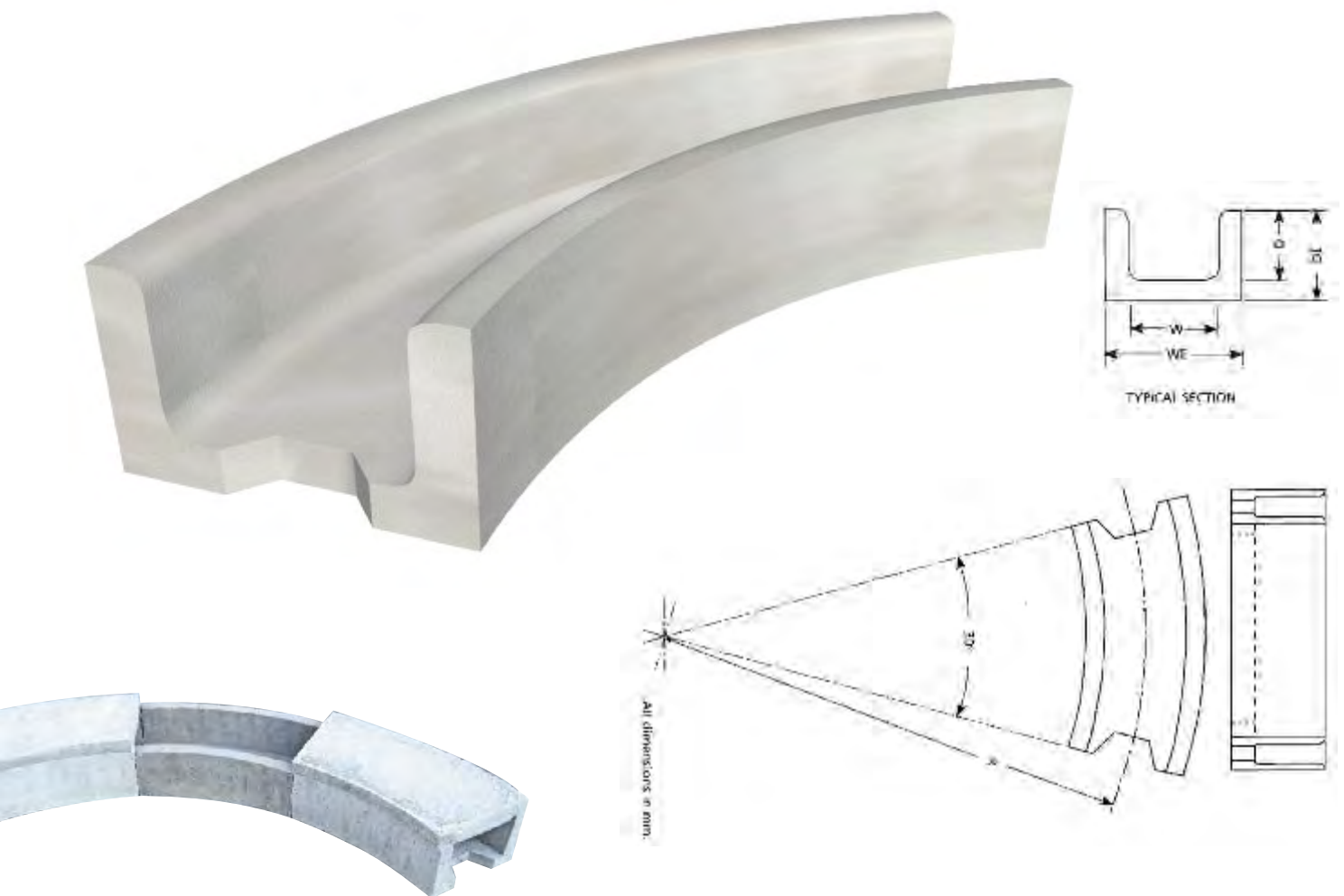

Product Description	To Suit	BRB Cat/No	Internal Dimensions			External Dimensions			Weight (kg)
			Width W	Depth D	Radius R	Width	WE Depth DE		
C.1.16 Trough	C.1.6	4/105101	100	90	1000	190	130	20	
C.1.11 Trough	C.1.6	4/105103	100	90	1500	190	130	29	
C.1.17 Trough	C.1.7	4/105106	130	130	1000	220	170	25	
C.1.12 Trough	C.1.7	4/105108	130	130	1500	220	170	37	
C.1.18 Trough	C.1.8	4/105111	150	200	1000	250	240	37	
C.1.13 Trough	C.1.8	4/105113	150	200	1500	250	240	54	
C.1.19 Trough	C.1.9	4/105116	190	130	1000	280	170	27	
C.1.14 Trough	C.1.9	4/105118	190	130	1500	280	170	35	
C.1.20 Trough	C.1.10	4/105121	250	130	1000	340	170	32	
C.1.15 Trough	C.1.10	4/105123	250	130	1500	340	170	47	
C.1.30 Trough	C.1.29	4/105126	350	130	1000	440	170	35	
C.1.31 Trough	C.1.29	4/105128	350	130	1500	440	170	56	
C.1.82 Trough	C.1.43	4/131415	350	300	1000	440	340	76	

- Standard Troughs and Lids are for pedestrian traffic only.
- Please note once the lid is fitted the internal capacity of the trough will be reduced.

LID CURVED

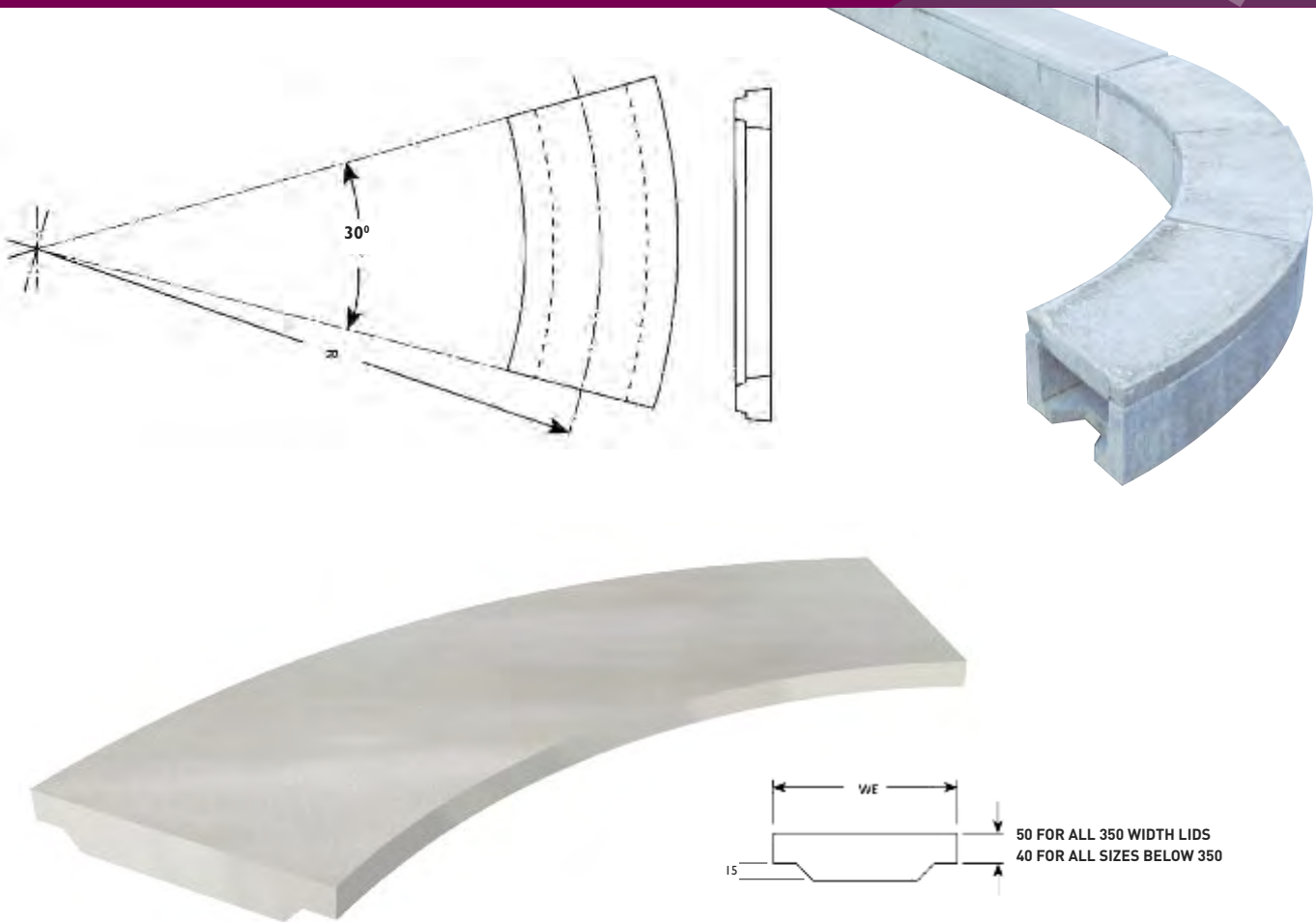

Product Description	To Suit	BRB Cat/No	Size of Trough		Radius R	Width WE	Weight (kg)
			Internal Dimensions Width W	Internal Dimensions Depth D			
C.1.16 Lid	C.1.6	4/105251	100	90	1000	190	12
C.1.11 Lid	C.1.6	4/105255	100	90	1500	190	17
C.1.17 Lid	C.1.7	4/105259	130	130	1000	220	15
C.1.12 Lid	C.1.7	4/105260	130	130	1500	220	20
C.1.18 Lid	C.1.8	4/105263	150	200	1000	250	15
C.1.13 Lid	C.1.8	4/105264	150	200	1500	250	22
C.1.19 Lid	C.1.9	4/105267	190	130	1000	280	17
C.1.14 Lid	C.1.9	4/105268	190	130	1500	280	27
C.1.20 Lid	C.1.10	4/105271	250	130	1000	340	22
C.1.15 Lid	C.1.10	4/105272	250	130	1500	340	32
C.1.30 Lid	C.1.29	4/105252	350	130	1000	440	34
C.1.31 Lid	C.1.29	4/105256	350	130	1500	440	52
C.1.82 Lid	C.1.43	4/131416	350	130	1000	440	34

- Standard Troughs and Lids are for pedestrian traffic only.
- Please note once the lid is fitted the internal capacity of the trough will be reduced.

T: 01606 79436
F: 01606 871590
E: sales@andertonconcrete.co.uk
W: www.andertonconcrete.co.uk

Anderton
 CONCRETE PRODUCTS LTD

TRANSITION TROUGH



Product Description To Suit	BRB Cat No	Weight (kg)	Pack Size
C/1/40 Trough C/1/7 to C/1/6	4/105381	43	20
C/1/38 Trough C/1/9 to C/1/7	4/105383	53	20
C/1/35 Trough C/1/10 to C/1/9	4/105387	58	16
C/1/36 Trough C/1/10 to C/1/8	4/105385	68	16
C/1/45 Trough C/1/43 to C/1/8	4/105391	93	6
C/1/44 Trough C/1/43 to C/1/29	4/105393	93	4
C/1/33 Trough C/1/29 to C/1/10	4/105389	67	15
C/1/61 Trough C/1/43 to C/1/7	4/105962	82	6
C/1/62 Trough C/1/43 to C/1/9	4/105964	85	6
C/1/63 Trough C/1/43 to C/1/10	4/105966	88	4
C/1/60 Trough C/1/29 to C/1/9	4/105960	62	12

- Standard Troughs and Lids are for pedestrian traffic only.
- Please note once the lid is fitted the internal capacity of the trough will be reduced.

TRANSITION LID

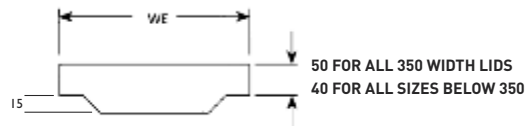

Product Description To Suit	BRB Cat No	Weight (kg)	Pack Size
C/1/40 Lid C/1/7 to C/1/6	4/105330	25	20
C/1/38 Lid C/1/9 to C/1/7	4/105329	30	40
C/1/35 Lid C/1/10 to C/1/9	4/105327	38	32
C/1/36 Lid C/1/10 to C/1/8	4/105328	36	32
C/1/45 Lid C/1/43 to C/1/8	4/105331	47	12
C/1/44 Lid C/1/43 to C/1/29	4/105397	65	24
C/1/33 Lid C/1/29 to C/1/10	4/105326	54	30
C/1/61 Lid C/1/43 to C/1/7	4/105963	47	15
C/1/62 Lid C/1/43 to C/1/9	4/105965	50	15
C/1/63 Lid C/1/43 to C/1/10	4/105967	54	15
C/1/60 Lid C/1/29 to C/1/9	4/105961	50	12

- Standard Troughs and Lids are for pedestrian traffic only.
- Please note once the lid is fitted the internal capacity of the trough will be reduced.

T: 01606 79436
F: 01606 871590
E: sales@andertonconcrete.co.uk
W: www.andertonconcrete.co.uk

Anderton
 CONCRETE PRODUCTS LTD

BALLAST RETAINING BOARDS

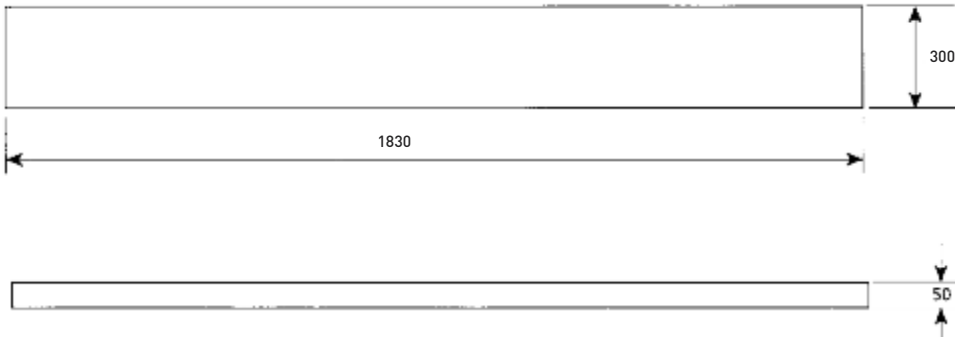

Anderton Concrete **ballast boards** are the ideal way to prevent the spread of ballast. Quick and easy to install Anderton ballast boards provide an instant solution to an ongoing problem. Anderton Concrete ballast boards contain steel reinforcement for extra strength and durability, they can also be delivered to site in composite loads with other Anderton Concrete railway products.

Product Description	BRB Cat/No	Size	Weight (kg)	Pack Size
Ballast Board	4/013298	1830 x 300 x 50	60	20
Ballast Board		1830 x 150 x 50	30	40

KING BOARDS



Anderton Concrete **king boards** provide the ideal engineered solution to create a line side recess to house vital infrastructure equipment or a position of safety for work personnel.

The heavy duty king board product has additional reinforcement detail to provide added protection against soil pressures.

Units are available in a variety of sizes.

Please contact our Sales Office with your specific requirements.

T: 01606 79436
F: 01606 871590
E: sales@andertonconcrete.co.uk
W: www.andertonconcrete.co.uk

Anderton
CONCRETE PRODUCTS LTD

STANDARD CATCHPITS

STANDARD
CATCHPIT
FRAME

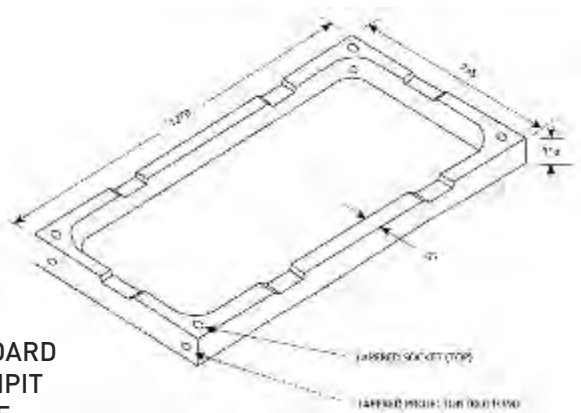

STANDARD
CATCHPIT
COVER

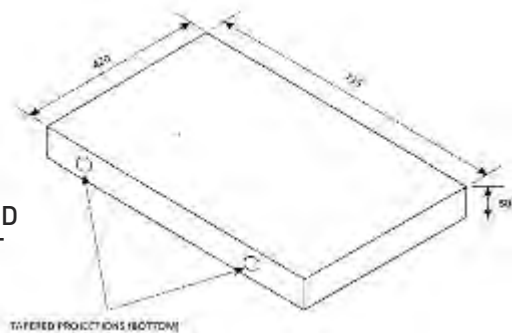

STANDARD
CATCHPIT
BASE

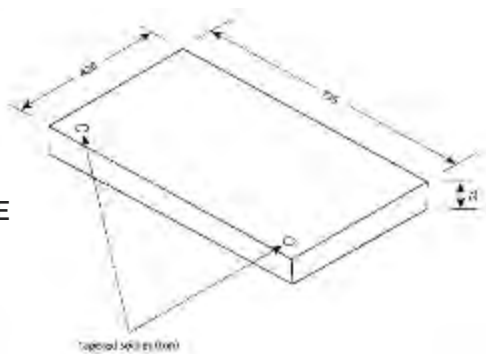

Product Description	BRB Cat/No	Weight (kg)	Pack Size
Standard catchpit cover	4/13508	38	30
Standard catchpit frame	4/13501	71	10
Standard catchpit base	4/13509	58	24

STANDARD CATCHPITS

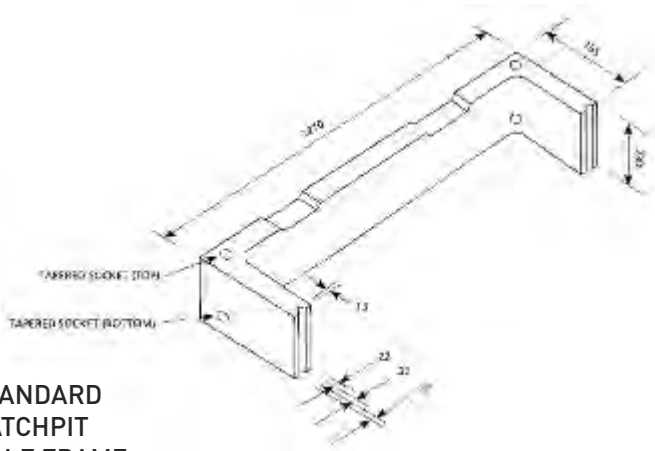

STANDARD
CATCHPIT
HALF FRAME

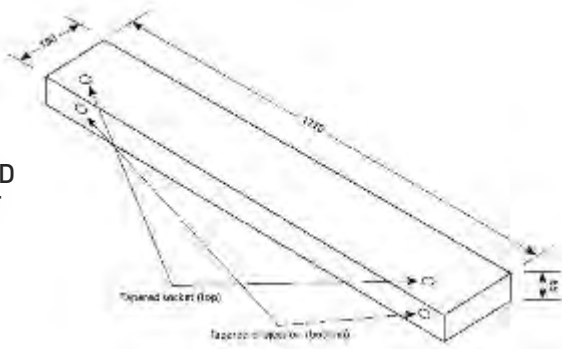

STANDARD
CATCHPIT
LEDGE

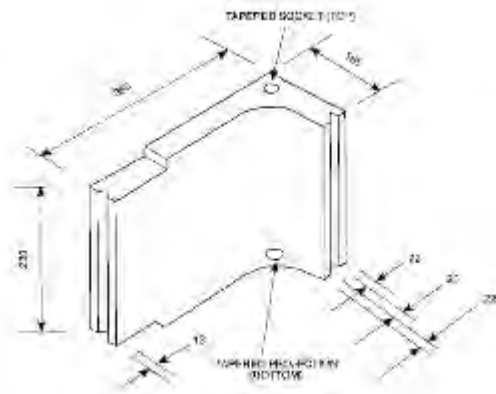

STANDARD CATCHPIT
CORNER (HANCED)



Product Description	BRB Cat/No	Weight (kg)	Pack Size
Standard catchpit half frame	4/13502	56	12
Standard catchpit ledge	4/13510	38	40
Standard catchpit corner LH	4/13506	20	8
Standard catchpit corner RH	4/13507	20	8

T: 01606 79436
 F: 01606 871590
 E: sales@andertonconcrete.co.uk
 W: www.andertonconcrete.co.uk

Anderton
 CONCRETE PRODUCTS LTD

MATISA CATCHPITS

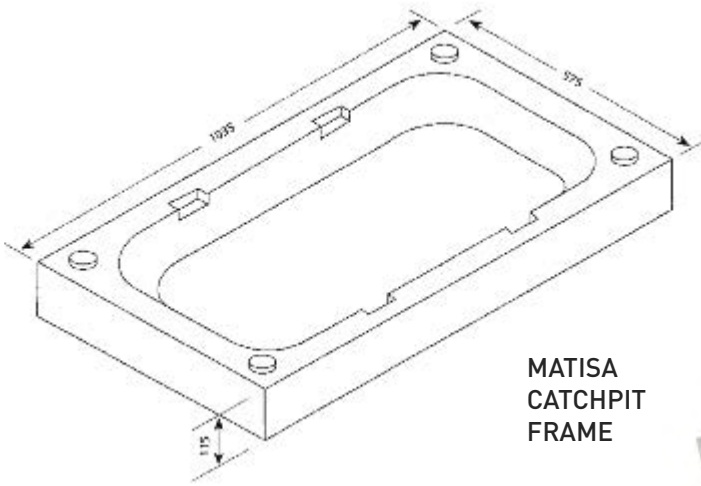

**MATISA
CATCHPIT
FRAME**

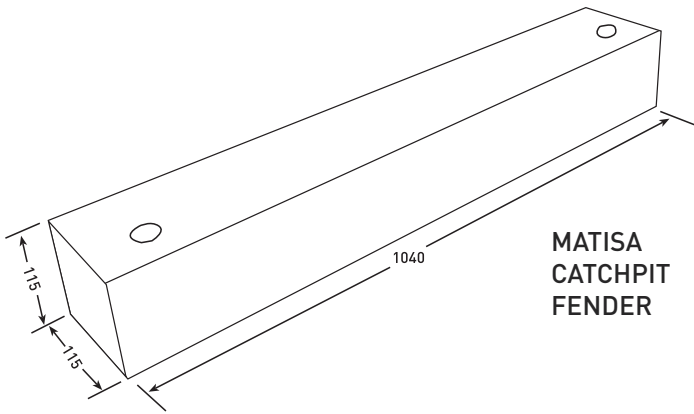

**MATISA
CATCHPIT
FENDER**



Product Description	BRB Cat/No	Weight (kg)	Pack Size
Matisa catchpit frame	4/104514	54	20
Matisa catchpit fender	4/104513	34	20

MATISA CATCHPITS

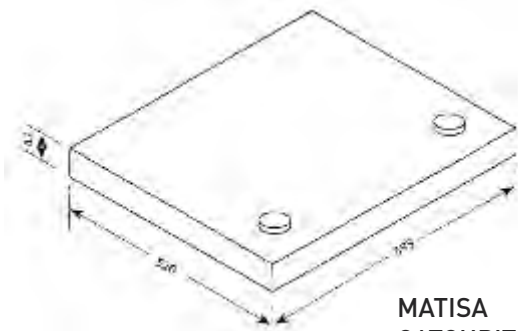

MATISA
CATCHPIT
COVER

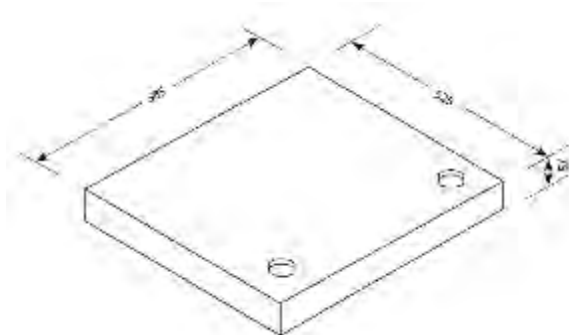

MATISA
CATCHPIT
BASES



Product Description	BRB Cat/No	Weight (kg)	Pack Size
Matisa catchpit cover	4/104512	35	20
Matisa catchpit base	4/104511	54	20

T: 01606 79436
 F: 01606 871590
 E: sales@andertonconcrete.co.uk
 W: www.andertonconcrete.co.uk

Anderton
 CONCRETE PRODUCTS LTD

SMALL APPARATUS CASE BASE

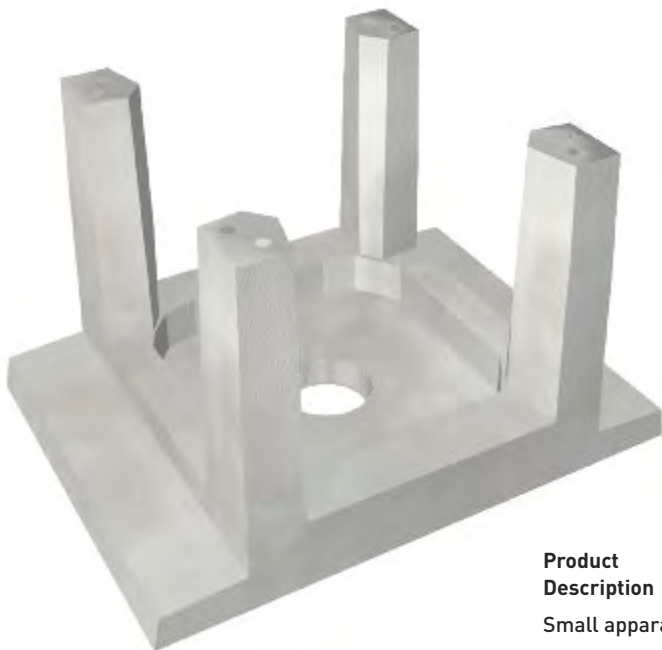
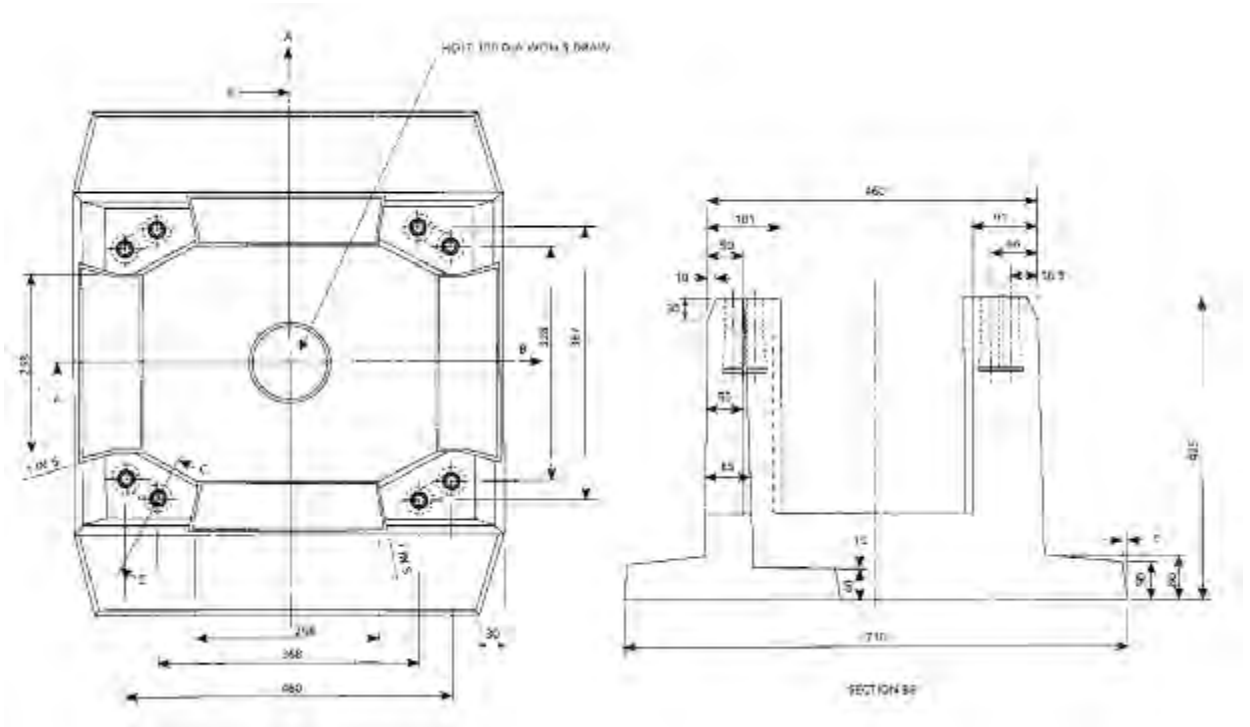

Product Description	BRB Cat/No	Length	Width	Depth	Weight (kg)	Pack Size
Small apparatus case base	4/104281	710	580	425	128	4

To be used in conjunction with Anderton filler blocks.

T: 01606 79436
 F: 01606 871590
 E: sales@andertonconcrete.co.uk
 W: www.andertonconcrete.co.uk

Anderton
 CONCRETE PRODUCTS LTD

CORNER UNITS & FILLER BLOCKS

CORNER UNIT

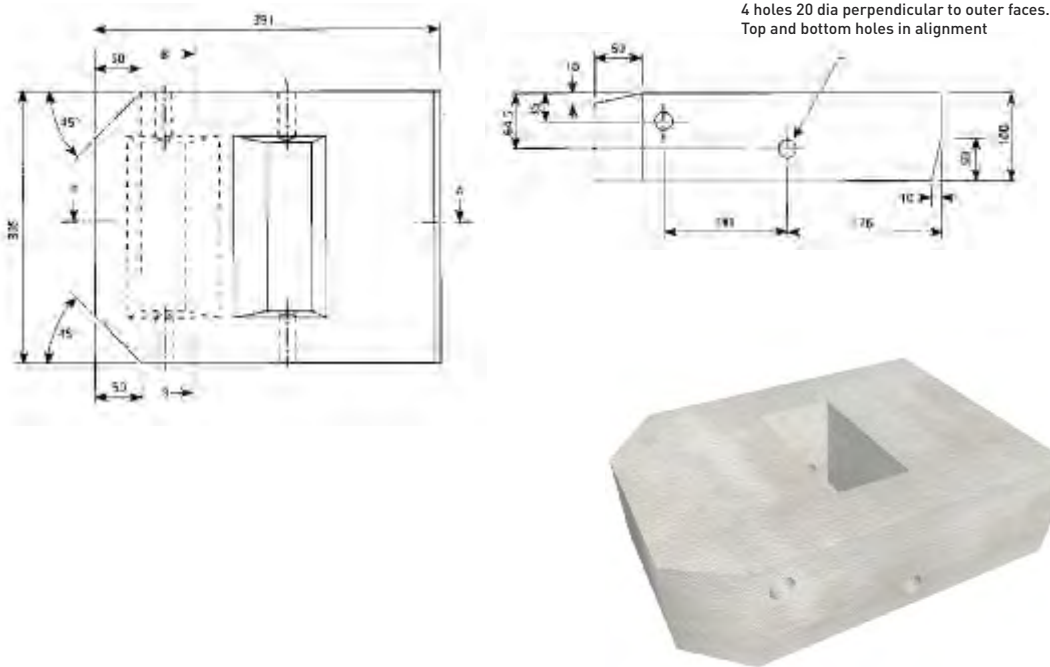

FILLER BLOCK

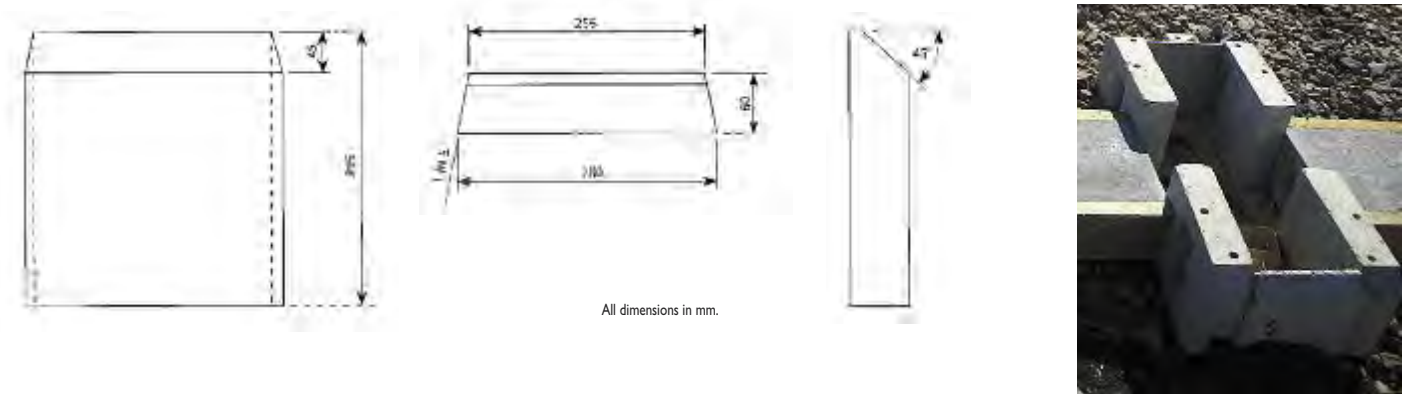

Product Description	BRB Cat/No	Length	Width	Depth	Weight (kg)	Pack Size
Corner Unit	4/104326	391	100	305	23	48
Filler Block	4/104301	280	60	295	11	96

Corner units to be used in conjunction with Anderton large apparatus case bases.
Filler blocks to be used in conjunction with Anderton large apparatus case bases or Anderton small apparatus case bases.



POINT ROD ROLLERS



**6 WAY POINT
ROD ROLLER**



**3 WAY POINT
ROD ROLLER**

Product Description	BRB Cat/No	Length	Width	Depth	Weight (kg)	Pack Size
3 Way Point Rod Roller	4/12773	220	273	606	34	12
6 Way Point Rod Roller	4/12774	220	480	606	62	6

T: 01606 79436
F: 01606 871590
E: sales@andertonconcrete.co.uk
W: www.andertonconcrete.co.uk

Anderton
 CONCRETE PRODUCTS LTD

MISCELLANEOUS RAIL PRODUCTS

Universal Telecoms Cabinet Base



Catalogue Number	004/012639
Weight	120kg
Number per pallet	2

Ground Signal SPT Base



Catalogue Number	004/012658
Weight	100kg
Number per pallet	2

Position Light Shunt Signal



Catalogue Number	004/104291
Weight	53kg
Number per pallet	9

Crank Leg Frame



Catalogue Number	004/015957
Weight	79kg
Number per pallet	6

Miniature Red/Green Light Unit Post Base



Catalogue Number	004/012657
Weight	240kg
Number per pallet	4

Signal Wheel Leg



Catalogue Number	004/015958
Weight	34kg
Number per pallet	3

STATION PLATFORM MATERIALS

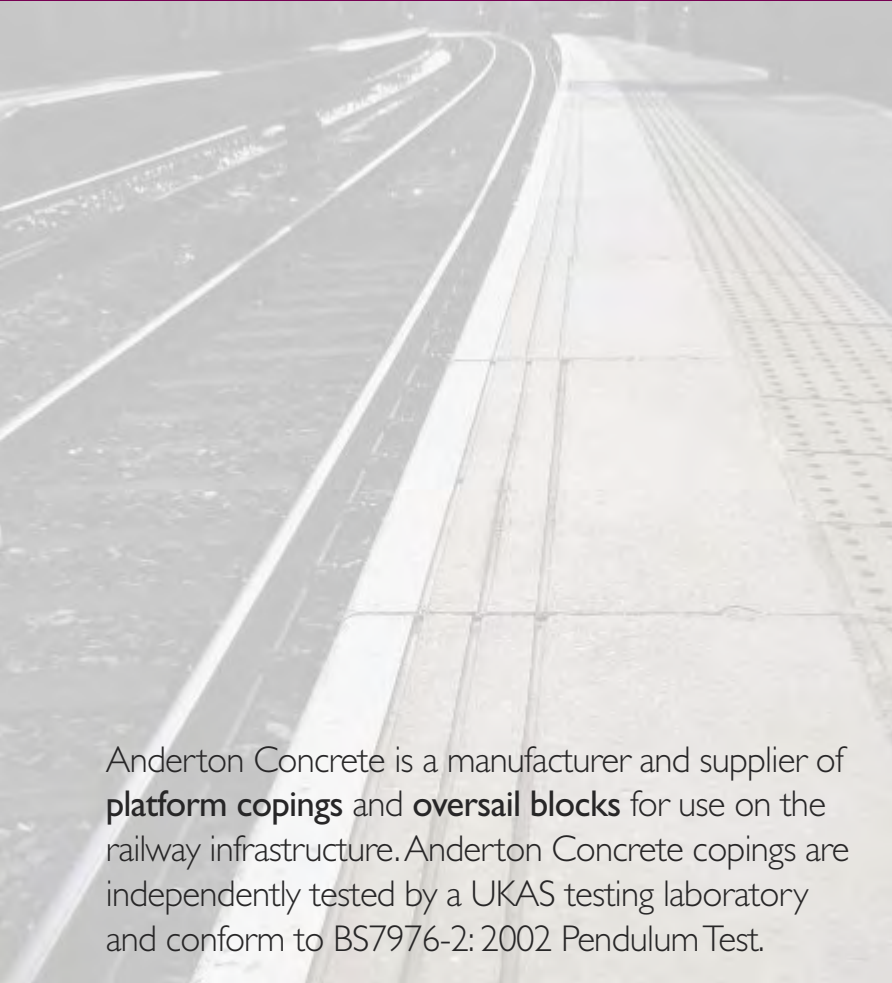

Anderton Concrete is a manufacturer and supplier of **platform copings** and **oversail blocks** for use on the railway infrastructure. Anderton Concrete copings are independently tested by a UKAS testing laboratory and conform to BS7976-2: 2002 Pendulum Test.

Anderton Concrete manufacture as standard various sizes of coping, in a traditional grey colour, in either an 'as cast' or exposed aggregate finish. Anderton Concrete also has the expertise to offer bespoke copers, in a variety of sizes, colours and surface finishes, please contact our sales office for further information.

Anderton Concrete oversail blocks are manufactured to complement the range of Anderton Concrete Platform Copings. Each unit has a side cut out to accommodate location dowels.



Typical platform construction



OVERSAILING BLOCKS



Exposed Aggregate finish



'As Cast' finish

T: 01606 79436
F: 01606 871590
E: sales@andertonconcrete.co.uk
W: www.andertonconcrete.co.uk

Anderton
CONCRETE PRODUCTS LTD

LONDON UNDERGROUND PRODUCTS



Anderton Concrete manufactures small precast items for the **London Underground** Infrastructure under strict factory controlled conditions backed by ISO9001 accreditation.

The standard product range has developed over many years to provide a comprehensive solution to both London Underground and Contractors alike.

For any inquiries from the standard product range or if you have any bespoke requirements please contact our Northwich sales office.

NOSING STONES



PC 20



PC 30

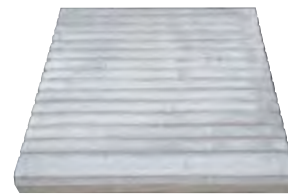

PC 10

Product Description	Dimensions L x W x D (mm)	Weight (kg)	Pack Size
PC10 Nosing Stone	600 x 600 x 65	60	10
PC20 Nosing Stone	910 x 685 185/90	150	5
PC30 Nosing Stone	910 x 685 x 90	135	5



PEDESTAL
BLOCK



NEGATIVE
SAFETY BLOCK



POSITIVE
SAFETY BLOCK



CABLE POSTS

Product Description	Dimensions L x W x D (mm)	Weight (kg)
1220mm Cable Post	165 x 75	37
1855mm Cable Post	165 x 75	58
2285mm Cable Post	165 x 75	68
3050mm Cable Post	165 x 75	91
4270mm Cable Post	165 x 152/75	165

Product Description	Weight (kg)
Cable Post Anchors to suit	53
Cable Post Wedges to suit	3

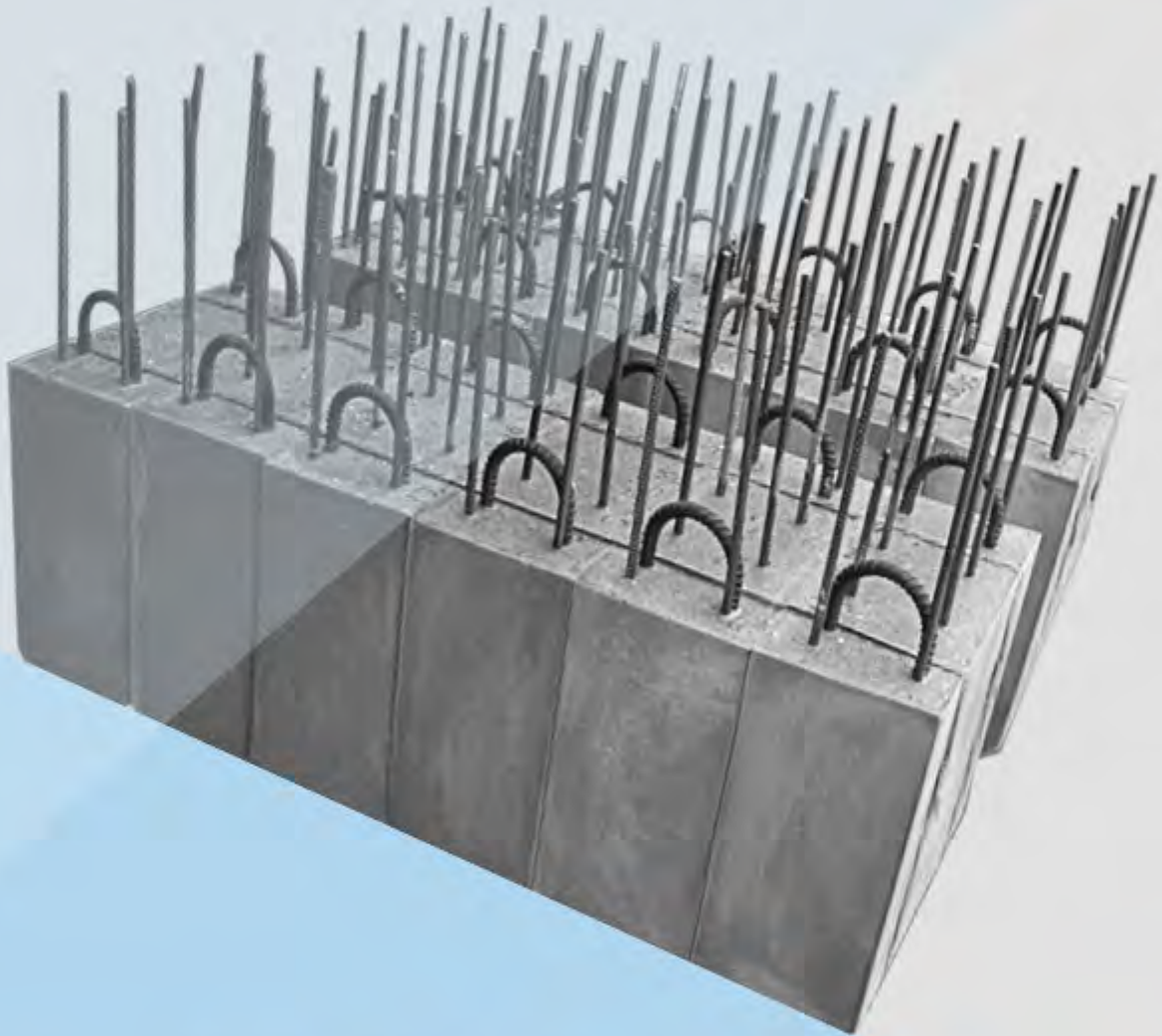

MISCELLANEOUS PRECAST

OVERVIEW - MISCELLANEOUS PRECAST

Anderton Concrete has for many years supplied various precast solutions for many different construction applications. An integral part of the traditional Anderton Concrete product portfolio is solutions for cable protection and cable identification. Anderton Concrete is the natural choice to the utility and power industries.

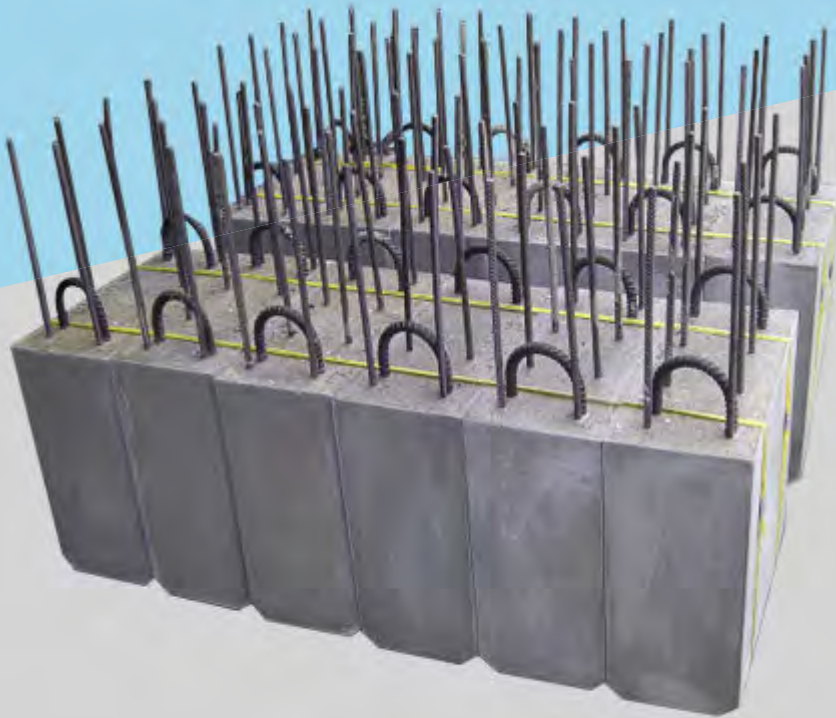

To further complement its already extensive product range Anderton Concrete offers a **bespoke precast** manufacturing service. The Anderton bespoke team offers experience and prides itself in its ability to turn around enquiries to meet the most demanding of deadlines. Anderton Concrete bespoke provides precast solutions to your individual concepts and designs.

UTILITY DUCTING

Anderton Concrete **ducting** has been at the forefront of cost-effective cable and pipeline protection for many years. Complete with removable lids for easy access Anderton Concrete offer a wide range of sizes to satisfy all applications and installation projects.

HI-AX LID

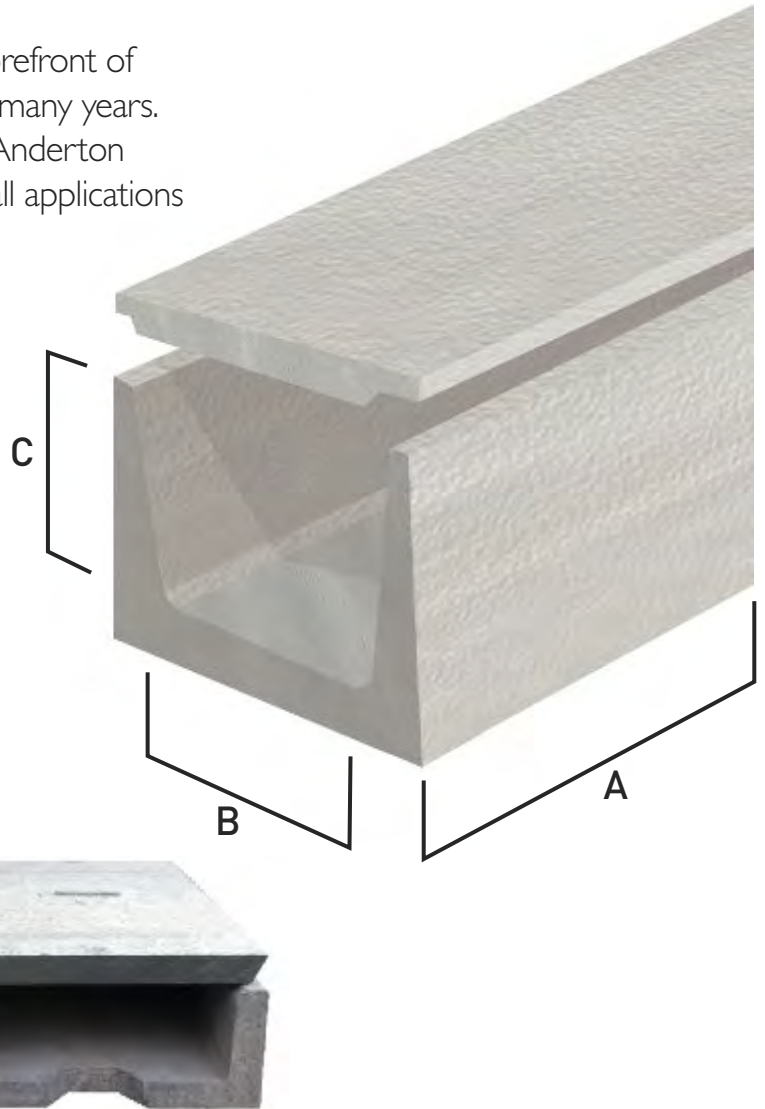

The **Anderton** Hi-Ax has been designed to withstand an 11.5 tonne wheel loading thus allowing vehicular overrun. The design is a steel framed construction, infilled with concrete to maintain the aesthetic appearance.

Please note lids with underbracing will reduce the internal capacity of the trough.

Product description	Size of trough			Trough kg	Lid kg	Pack Size
	A	B	C			
Joint Bay	457	475	305	82	38	8
AA Trough	610	345	305	90	37	8
Type R	914	150	115*	38	12	18 With lids
Type Z	475	685	345*	102	46	4
Sutton	610	585	305	133	78	8
7 x 9	760	175	215	68	28	8
ANDERTON 1	400	1000	750	292	226	1
ANDERTON 2	400	750	750	271	178	2
ANDERTON 3	400	500	750	245	142	2

* 2 lids per trough unit

T: 01606 79436
 F: 01606 871590
 E: civils@andertonconcrete.co.uk
 W: www.andertonconcrete.co.uk

Anderton
 CONCRETE PRODUCTS LTD

CABLE PROTECTION & IDENTIFICATION









Anderton Concrete **cable covers** are used extensively throughout the UK serving as a warning to personnel working or excavating in close proximity to pipes or live cables. Additionally, cable covers act as a physical barrier against accidental damage and help to eliminate costly repairs and regular maintenance. They also offer personal protection to site operatives.

Service Identification

The Anderton Concrete range of marker posts and marker blocks identify the exact location of buried utility services. They act as a warning against accidental damage and help to reduce expensive search costs.

CABLE PROTECTION & IDENTIFICATION

 <p>31 kg</p> <p>MARKER POST Type M4 Length 1230mm</p>	 <p>24 kg</p> <p>TYPE 2 MARKER POST Head to take 100mm x 76mm plate Length 762mm</p>	 <p>50 kg</p> <p>DUCT MARKER BLOCK 305 x 305 x 230mm</p>	 <p>49 kg</p> <p>DUCT MARKER POST 1525 x 100 x 100mm</p>												
 <p>CABLE COVER</p> <p>Available in the following sizes:</p> <table border="1"> <thead> <tr> <th>mm</th> <th>kg</th> <th>Pack Size</th> </tr> </thead> <tbody> <tr> <td>914 x 152 x 63/38</td> <td>15.6</td> <td>100</td> </tr> <tr> <td>914 x 229 x 63/38</td> <td>23</td> <td>63</td> </tr> <tr> <td>914 x 305 x 63/38</td> <td>29</td> <td>49</td> </tr> </tbody> </table> <p>Concave/convex ends. "DANGER ELECTRICITY" as standard. Other lettering on request.</p>		mm	kg	Pack Size	914 x 152 x 63/38	15.6	100	914 x 229 x 63/38	23	63	914 x 305 x 63/38	29	49	 <p>EARTH ROD CORE AND SURROUND 315 x 315 x 210mm</p> <p>34 kg</p>	
mm	kg	Pack Size													
914 x 152 x 63/38	15.6	100													
914 x 229 x 63/38	23	63													
914 x 305 x 63/38	29	49													
		 <p>BLOCK TYPE MARKER 305 x 305 x 152mm - 33 kg 610 x 610 x 102mm - 87 kg</p> <p>Both with space for 101 x 76mm lead insert</p>													

STAYBLOCK

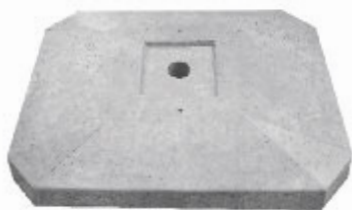

Type	Size	Hole	kg	No. per pack
Stayblock 30	500 x 390 x 50	30	24	36
Stayblock 75	500 x 390 x 50	75	24	36
Stayblock Z	640 x 505 x 65	Square	70	20

Anderton **Stayblocks** are most commonly used on overhead line construction projects. These stayblocks anchor staywires from pylons or posts to provide a long lasting, secure solution.

T: 01606 79436
F: 01606 871590
E: civils@andertonconcrete.co.uk
W: www.andertonconcrete.co.uk

Anderton
CONCRETE PRODUCTS LTD

BEAM & BLOCK FLOOR ANCILLARIES

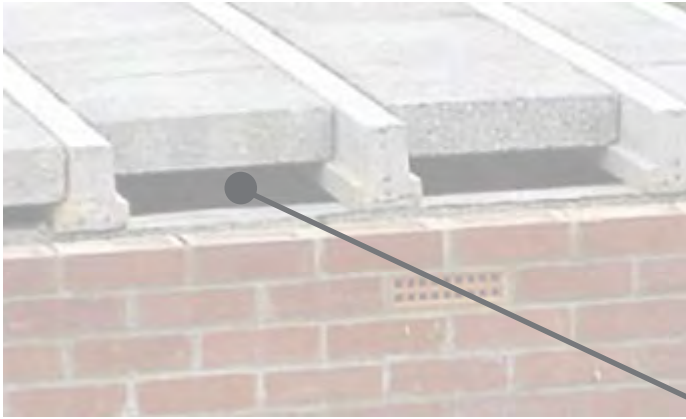

Beam and block flooring is the traditional and cost-effective suspended flooring system for ground and upper floors and Anderton Concrete now offers pre-cast ancillary products to complement this system.

Closure Block

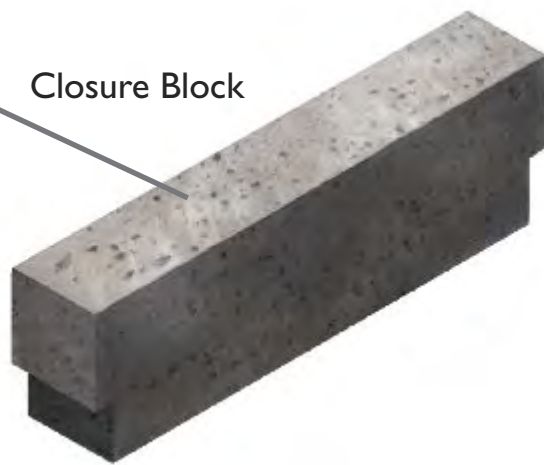

Coursing Slip

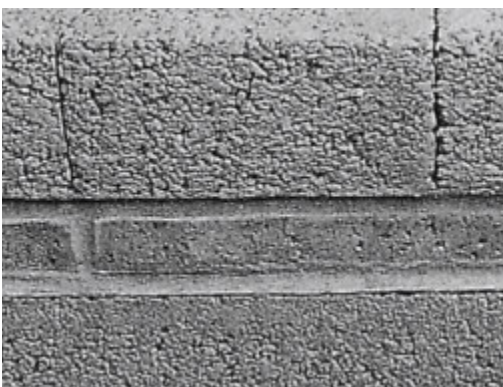

Anderton Concrete **coursing slips** save a split face brick course at side bearing or between end bearing.

Anderton Concrete **closure blocks** are designed to fit between floor beams on the bearing ends. This saves cutting bricks or blocks when building the wall through the ends of the beams using standard centres.

COURSING SLIPS

Product	Length	Width	Height	Weight	Pack size
35mm Slip	385	100	35	2.3	228
45mm Slip	385	100	45	2.9	204

CLOSURE BLOCKS*

Product	Length	Width	Height	Weight	Pack size
TCL100	100	528	138	13.6	56
TCL140	140	528	138	19.4	56
TCL540	100	540	165	16.2	60
TCL440	100	440	165	13.2	80

*Closure Blocks are available in 7N/mm² strength as standard. For other strengths please contact Sales Office.

LOCATION MAP

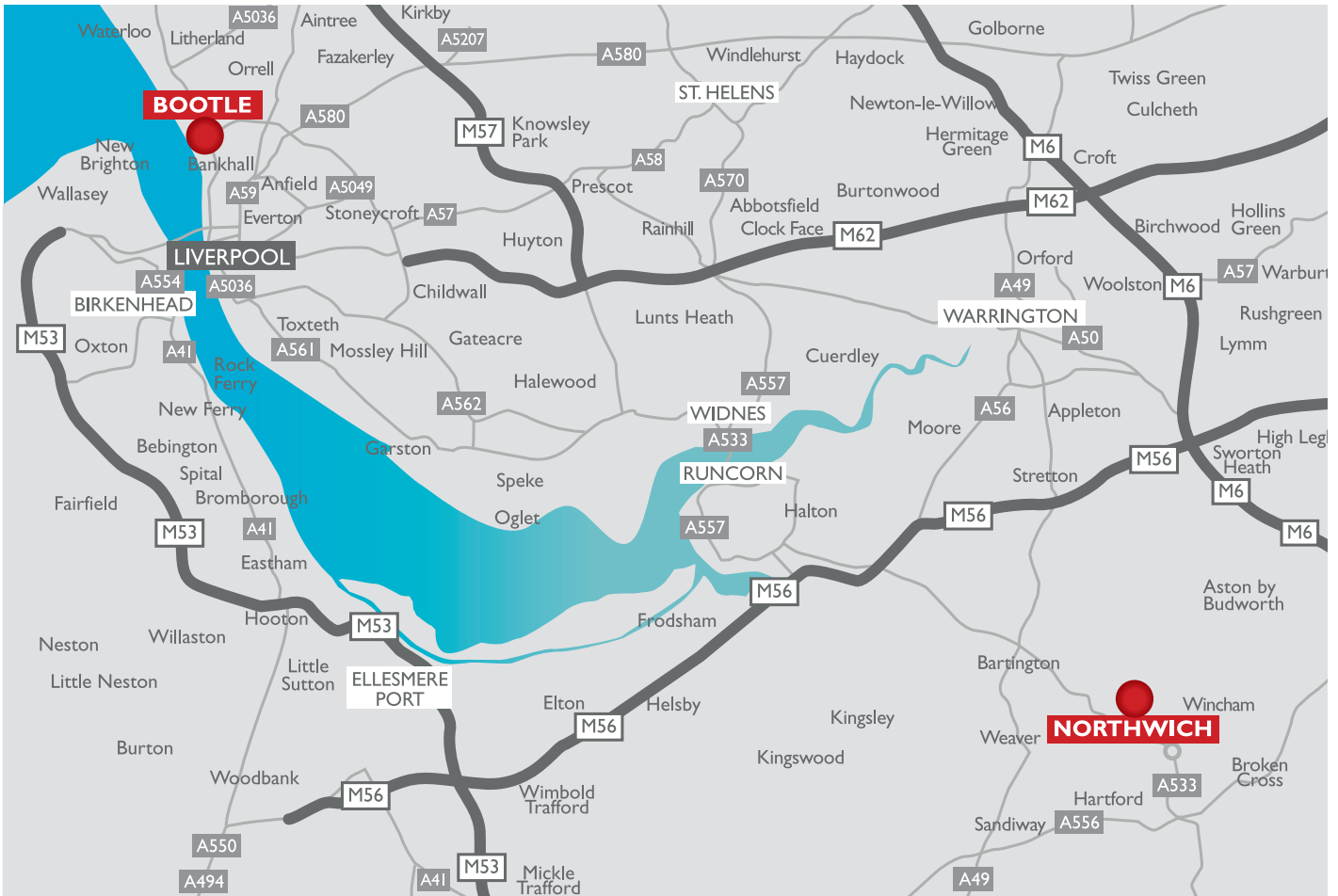

Contact Anderton Concrete

For more information or a quotation for any of our products please contact us using the details below and one of our team will be happy to help.

HEAD OFFICE

Anderton Concrete Products Limited (Cheshire)
Units 1 & 2, Cosgrove Business Park
Soot Hill
Anderton
Northwich
Cheshire CW9 6AA

T: 01606 79436 (Fencing, Building & Rail Products)
F: 01606 871590
E: sales@andertonconcrete.co.uk

T: 01606 535300 (Civils)
F: 01606 75905
E: civils@andertonconcrete.co.uk

MERSEYSIDE

Anderton Concrete Products Limited (Merseyside)
Bridle Way
Bootle
Merseyside L30 4UA



Anderton

CONCRETE PRODUCTS LTD

A: Anderton Wharf
Units 1 & 2
Cosgrove Business Park
Soot Hill
Anderton
Northwich
Cheshire CW9 6AA

T: 01606 79436
F: 01606 871590
T: 01606 535300 Civils
F: 01606 75905 Civils

E: sales@andertonconcrete.co.uk
E: civils@andertonconcrete.co.uk
W: www.andertonconcrete.co.uk