

Series 7500/75 & 7600/76

Roller Bearing Gear Pumps, Motors and Flow Dividers

- Single or multiple units available.
- Piggy back options available.
- Displacement 33 cc/rev to 199 cc/rev.
- Gear widths 1/2" to 3".
- Minimum operating speed 400 rpm.
- Maximum continuous operating speed 2000 rpm.
- Maximum continuous operating pressure 2500 psi (207 bar).
- Drive shaft PL factor: Integral 12000, Continental 10000.
- Cast iron construction.
- Dowelled units available.

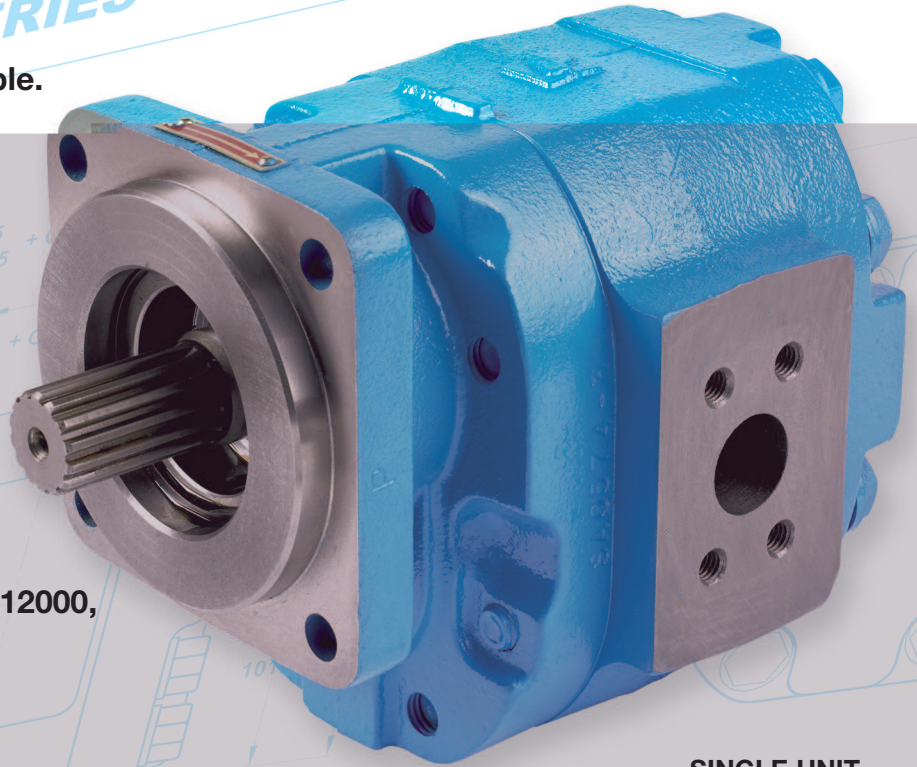

SINGLE UNIT

Mounting Flange Options:

SAE 'B' 4 bolt, SAE 'C' 2 bolt, SAE 'C' 4 bolt, SAE 'D' 4 bolt.

Drive Shaft Options:

SAE 'C' 14 tooth, SAE 'D' splined, SAE 'C' keyed.

Various Porting Options:

BSP, SAE, NPT, JIC (ODT).

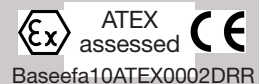

Recommended Operating Conditions:

Fluid viscosity, normal operating conditions 16 to 220 cst.

Fluid temperature should not exceed 65 deg. C.

Fluid cleanliness, 10 micron filter with Beta 200 rating is recommended.

Inlet pressure; for best operation with mineral oil, pressure should not exceed

MULTIPLE UNIT

Performance and Dimensions overleaf

Please discuss your application with our sales engineers.

Series 7500 Pumps, Motors and Flow Dividers

PERFORMANCE DATA

Pump Performance

Output- L/min/igpm – Input-Kw/Horsepower ▶		Input Speed – rpm							
		1000		1500		1800			
Output	Input	Output	Input	Output	Input	Output	Input		
05	1/2	33	207/3000	28 / 6.2	10 / 13	43 / 9.5	14 / 19	52 / 11.5	17 / 23
07	3/4	50	207/3000	41 / 9.0	14 / 19	64 / 14.1	22 / 29	78 / 17.2	26 / 34
10	1	66	207/3000	55 / 12.1	20 / 26	85 / 18.7	29 / 38	104 / 22.9	34 / 45
12	1.1/4	83	207/3000	71 / 15.6	24 / 32	107 / 23.6	35 / 47	132 / 29.1	42 / 56
15	1.1/2	99	180/2610	86 / 18.9	28 / 37	130 / 28.6	42 / 56	158 / 34.8	50 / 67
17	1.3/4	116	180/2610	102 / 22.5	32 / 42	155 / 34.1	49 / 65	189 / 41.6	58 / 77
20	2	132	180/2610	118 / 26.0	36 / 48	179 / 39.4	55 / 73	215 / 47.4	66 / 88
22	2.1/4	149	180/2610	134 / 29.5	41 / 54	199 / 43.8	61 / 82	241 / 53.1	74 / 98
25	2.1/2	166	180/2610	148 / 32.6	45 / 60	222 / 48.9	68 / 90	268 / 59.0	81 / 109
27	2.3/4	182	155/2250	167 / 36.8	50 / 66	248 / 54.6	75 / 100	298 / 65.6	92 / 122
30	3	198	155/2250	185 / 40.7	55 / 73	275 / 60.6	84 / 112	330 / 72.7	101 / 134

● Flows quoted are at test pressures of 138 bar/2000 psi, using 32cSt oil at 65 deg C.

● Performance data is derived from tests conducted to simulate working conditions. Continuous operation at maximum performance may compromise unit life.

If in doubt when specifying, please consult our sales department.

Motor Performance

		Output Speed – rpm					
		800	1200	1600	2000		
Gear widths – code	10	1	Output Kw / hp	11.0 / 14.5	15.0 / 20.0	19.5 / 26.0	23.0 / 30.5
			Output Nm / in.lb	124.5 / 1100	123.0 / 1090	117.5 / 1040	109.5 / 970
			Input l.min / igpm	72.5 / 16.0	100.0 / 22.0	127.5 / 28.0	154.5 / 34.0
	15	1.1/2	Output Kw / hp	16.5 / 22.0	23.0 / 31.0	30.5 / 41.0	37.5 / 50.0
			Output Nm / in.lb	192.0 / 1700	190.0 / 1680	186.5 / 1650	181.5 / 1600
			Input l.min / igpm	104.0 / 23.0	143.0 / 31.5	186.5 / 41.0	225.0 / 49.5
	20	2	Output Kw / hp	22.0 / 29.0	32.0 / 42.5	41.5 / 55.5	51.0 / 68.0
			Output Nm / in.lb	256.5 / 2270	255.5 / 2260	251.0 / 2220	246.5 / 2180
			Input l.min / igpm	129.5 / 28.5	184.0 / 40.5	241.0 / 53.0	295.5 / 65.0
	25	2.1/2	Output Kw / hp	28.0 / 37.5	41.0 / 54.5	53.5 / 71.5	65.0 / 87.0
			Output Nm / in.lb	331.0 / 2930	328.0 / 2900	321.0 / 2840	312.0 / 2760
			Input l.min / igpm	159.0 / 35.0	227.0 / 50.0	293.0 / 65.0	363.5 / 80.0
30	3	Output Kw / hp	35.0 / 47.0	52.0 / 69.0	67.0 / 89.5	82.0 / 109.0	
		Output Nm / in.lb	418.0 / 3700	416.0 / 3680	404.0 / 3570	388.0 / 3430	
		Input l.min / igpm	186.0 / 41.0	272.5 / 60.0	354.5 / 78.0	434.0 / 95.5	

* These gear widths are the popular sizes for motor configurations but any of the gear widths listed in the Pump Performance table can be supplied.

WEIGHTS (approximate)

Gear widths (ins)	1/2	3/4	1	1.1/4	1.1/2	1.3/4	2	2.1/4	2.1/2	2.3/4	3
Single unit (kg)	30.5	32.0	33.0	34.0	35.0	36.0	37.5	39.0	40.0	41.0	42.0

For multiple unit weights, please consult our sales department.

DIMENSIONS

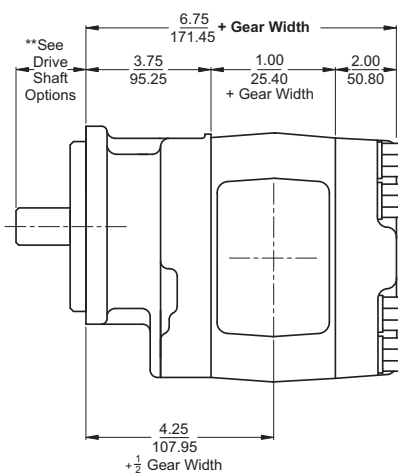

SINGLE UNIT

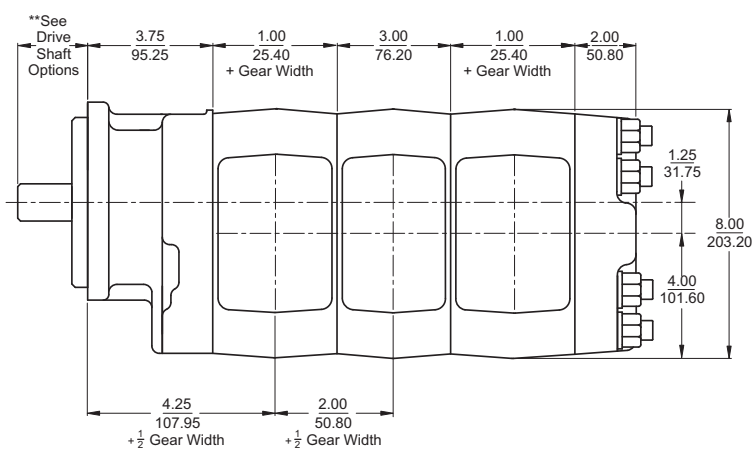

MULTIPLE UNIT

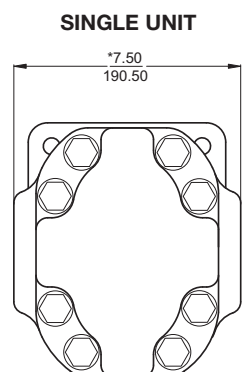

*Standard port arrangement, dimension will change with type of port.

**Dimensional information for mounting flange and shaft options are shown on the attached Data Sheet FS100.

HYDRA-PERM-CO LTD

HYDRAULIC ENGINEERS

Unit 20 Silver Court ■ Intercity Way ■ Bramley ■ Leeds ■ West Yorkshire ■ LS13 4LY ■ UK
 Tel: +44 (0) 1132 361367 ■ Fax: +44 (0) 113 239 4207 ■ e-mail: info@hydra-perm.co.uk ■ website: www.hydra-perm.co.uk