

Astrolite

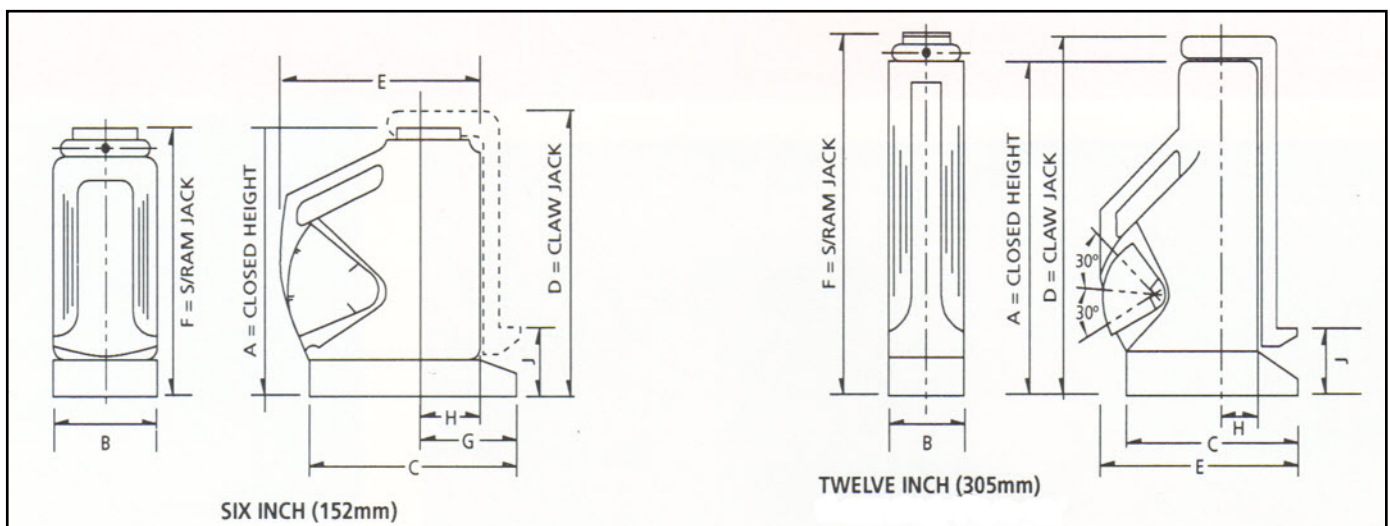

60 Tonne Range



MODEL NO.	JACK CAPACITY TONNES	CLAW CAPACITY TONNES	STROKE (MM)	WEIGHT (KG)	CLOSED HEIGHT A,D,F	BASE WIDTH B	BASE LENGTH C	TOE HEIGHT J
JACK WITH PLAIN RAM								
UP660S	60		152	28	293	190	251	
UP1260S	60		305	44	500	190	342	
JACK WITH CLAW								
UP660C	60	24	152	44	327	190	342	73
UP1260C	60	24	305	65	540	190	342	73
JACK WITH CLAW BASE								
UP660LC	60		152	29	293	190	342	
JACK WITH SCREWED RAM WITH LOCKING COLLAR								
UP660SR	60		152	30	330	190	251	
UP1260SR	60		305	46	536	190	342	

Optional pressure gauges with mounting kits are available. More details on request

Contact our sales team on **01675 475 427**

www.astromanufacturing.co.uk e-mail astroukltd@gmail.com