

Astrolite

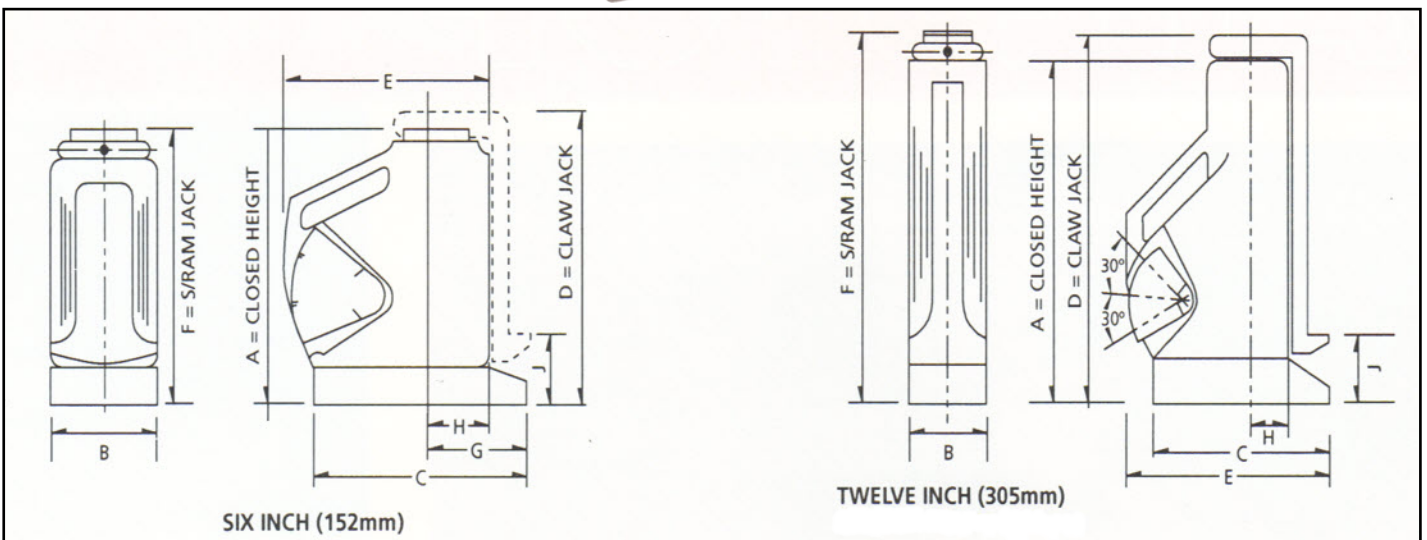

35 Tonne - 40 tonne Range



MODEL NO.	JACK CAPACITY TONNES	CLAW CAPACITY TONNES	STROKE (MM)	WEIGHT (KG)	CLOSED HEIGHTS A,D,F	BASE WIDTH (B)	BASE LENGTH C	TOE HEIGHT (J)
JACK WITH PLAIN RAM								
UP635S	35		152	21	263	160	225	
UP1235S	35		305	33	438	160	306	
JACK WITH CLAW								
UP635C	35	14	152	29	280	160	225	73
UP1235C	35	14	305	42	456	160	306	73
JACK WITH CLAW BASE								
UP635LC	35		152	22	263	160	225	
JACK WITH SCREWED RAM WITH LOCKING COLLAR								
UP635SR	35		152	22	289	160	225	
UP1235SR	35		305	34	464	160	306	

Optional pressure gauges complete with mounting kits are available. More details on request

Contact our sales team on **01675 475427**

www.astromanufacturing.co.uk e-mail astroukltd@gmail.com