

Astrolite

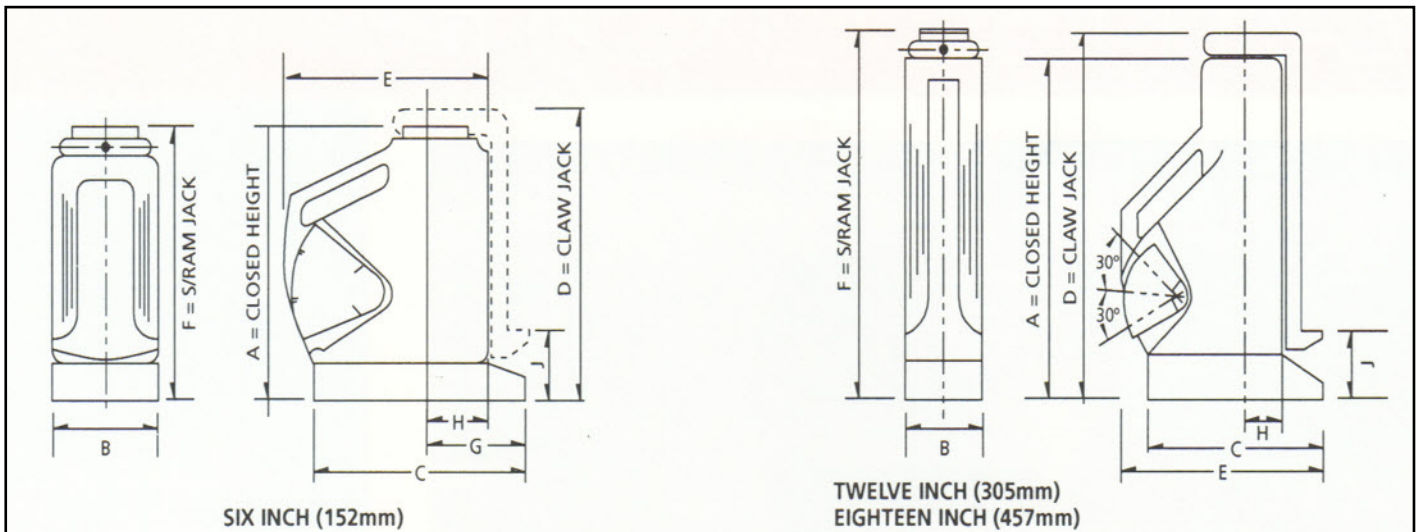

30 Tonne Range



MODEL NO.	JACK CAPACITY TONNES	CLAW CAPACITY TONNES	STROKE (MM)	WEIGHT (KG)	CLOSED HEIGHTS A,D,F	BASE WIDTH B	BASE LENGTH C	TOE HEIGHT J
JACK WITH PLAIN RAM								
UP630S	30		152	16	263	140	203	
UP1230S	30		305	24	451	140	273	
JACK WITH CLAW								
UP630C	30	12	152	21	281	140	273	73
UP1230C	30	12	305	32	472	140	273	73
JACK WITH CLAW BASE								
UP630LC	30		152	16.5	263	140	273	
JACK WITH SCREWED RAM WITH LOCKING COLLAR								
UP630SR	30		152	17	292	140	203	
UP1230SR	30		305	25	479	140	273	

Optional pressure gauges complete with mounting kits are available. More detail on request

Contact our sales team on **01675 475427**

www.astromanufacturing.co.uk e-mail astroukltd@gmail.com