

Astrolite

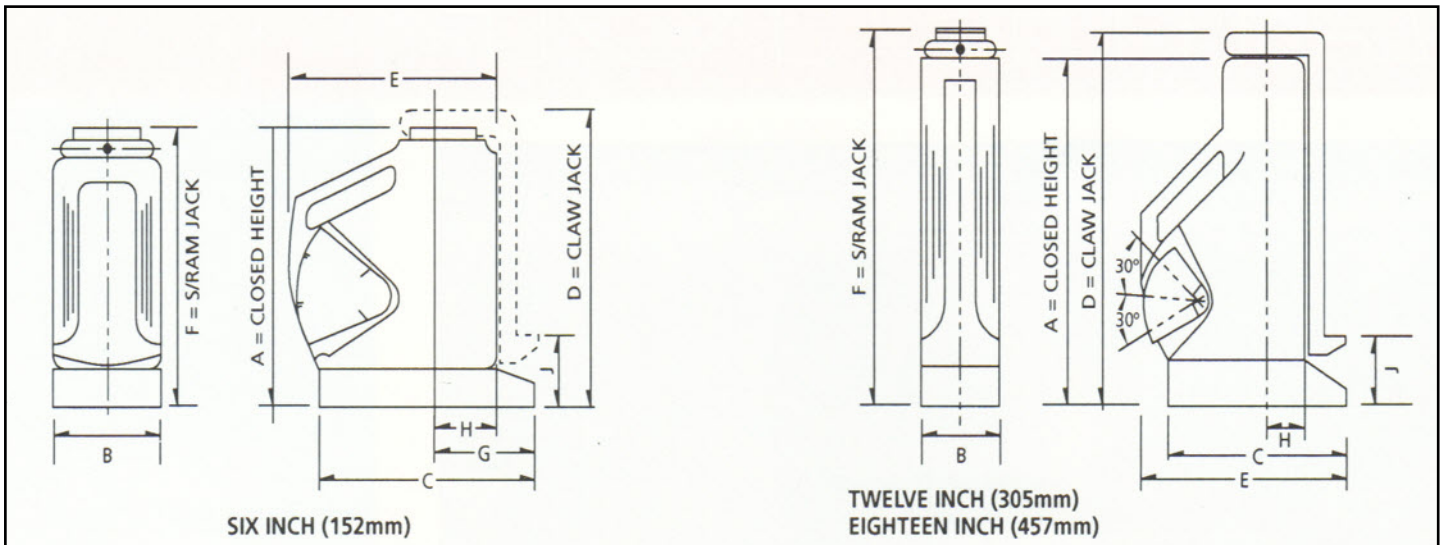

20 Tonne Range



MODEL NO.	JACK CAPACITY TONNES	CLAW CAPACITY TONNES	STROKE (MM)	WEIGHT (KG)	CLOSED HEIGHTS A,D,F	BASE WIDTH B	BASE LENGTH C	TOE HEIGHT J
JACK WITH PLAIN RAM								
UP620S	20		152	11	263	121	178	
UP1220S	20		305	17	438	121	246	
JACK WITH CLAW								
UP620C	20	8	152	15	280	121	246	67
UP1220C	20	8	305	23	456	121	246	67
JACK WITH CLAW BASE								
UP620LC	20		152	11.5	263	121	246	
JACK WITH SCREWED RAM WITH LOCKING COLLAR								
UP620SR	20		152	13	289	121	178	
UP1220SR	20		305	19	464	121	246	

Optional pressure gauges complete with mounting kits are available. More detail on request

Contact our sales team on **01675 475427**

www.astromanufacturing.co.uk/ C1e-mail astroukltd@gmail.com