

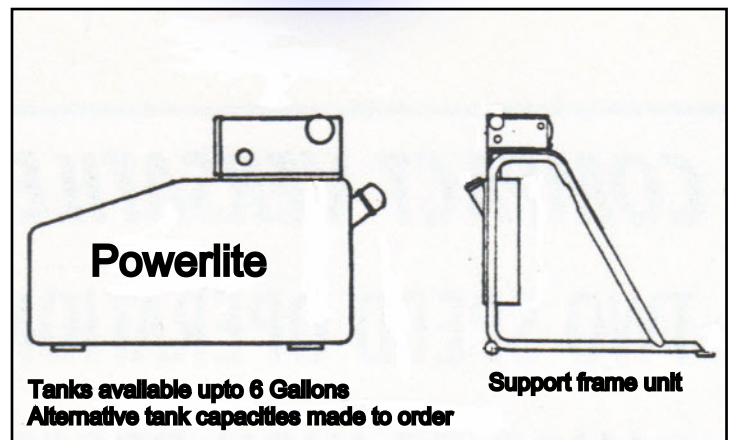

## Technical Information Powerlite Pump

- A Compact and Versatile Pump Unit
- Two speed operation
- Range of high pressures
- Fast low pressure displacement
- Compact design
- Highly adaptable
- Suitable for use with various fluids
- Gauges and tanks available

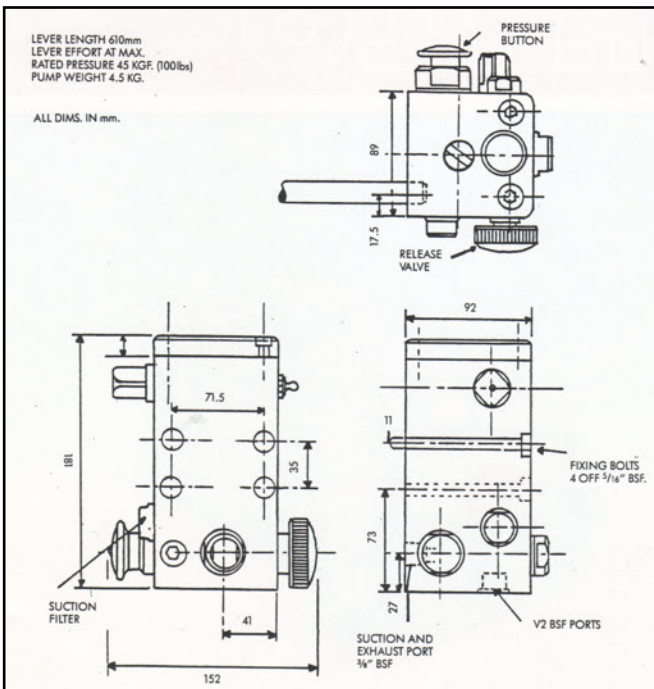

<b>Max. Working Pressure (p.s.i.)</b>	<b>10,000 (700 BAR)</b>	<b>8,000 (552 BAR)</b>	<b>6,500 (448 BAR)</b>	<b>4500 (310 BAR)</b>	<b>2,500 (172 BAR)</b>	<b>1,600 (110 BAR)</b>
<b>Diameter of high-Pressure plunger</b>	<b>1/2 in (12.7)</b>	<b>9/16 in (14.3)</b>	<b>5/8 in (16.0)</b>	<b>3/4 in (19.0)</b>	<b>1 in (25.4)</b>	<b>1 1/4 in (32.0)</b>
<b>Cu. Ins. Displaced Per stroke</b>	<b>0.221 (3cm sq)</b>	<b>0.279 (4cm sq)</b>	<b>0.345 (5cm sq)</b>	<b>0.445 (7cm sq)</b>	<b>0.883 (13cm sq)</b>	<b>1.380 (20cm sq)</b>

A comprehensive Range of Tanks, Pressure Gauges, Hoses and Couplings are available

Contact our sales team on **01675 475427**

[www.astromanufacturing.co.uk](http://www.astromanufacturing.co.uk) e-mail. [astroukltd@gmail.com](mailto:astroukltd@gmail.com)