

TITON



Titon 5 tonne Range

The 5 tonne hydraulic jack is an ideal jack for applications that require a low starting Height and require high lift. The Titon 5 jack has the following advantages.

- 5 Tonne capacity on Head or Toe
- Low toe height 41mm
- Integral Pump and Pressure valve
- 178mm lift height
- Vertical & Horizontal operation
- Robust Ferrous Construction
- Easy operation and transportation
- Manufactured in the UK
- CE Certified

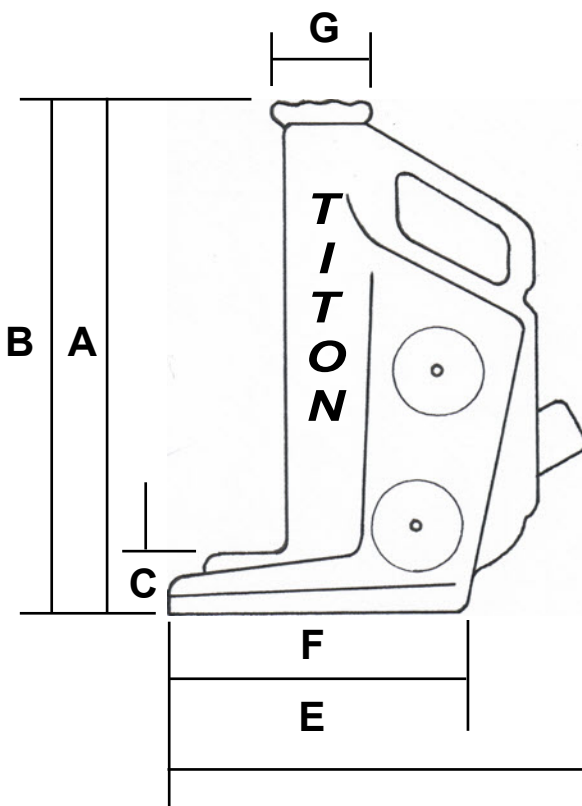

Capacity (Tonne)	5 tonne
Order Code	Titon 5
Dimensions(mm)	
A CLOSED HEIGHT	327
B FULL STROKE	505
C	41
D	258
E	255
F	219
G WIDTH	63.5
H CLAW WIDTH	57
I O/A WIDTH	114.3
Specifications	
Lever Weight	3.63kgs
Jack Weight (Inc. Oil)	18kgs
Lift per Stroke	5.5mm
Max.Handle Effort	45kgf

Contact our sales team on *01675 475427*

www.astromanufacturing.co.uk e-mail astroukltd@gmail.com