

## Product information sheet

Product Name: **Rubber Parking Curb**

Models: 6', 4', 3' long

Manufacturer: GNR Technologies Inc., 990 Upton, Lasalle, QC H8R 2T9  
Tel.: (514) 366-6116, Fax: (514) 366-6440

Product Description: 1. Material: compression molded composite of the 100% recycled rubber and polyurethane prepolymer

2. Physical properties of the rubber composite:

- |  |                             |              |
|--|-----------------------------|--------------|
| a) Density   | 0.6 oz/cu in                | (ASTM C642)  |
| b) Durometer Hardness                                | 65A ± 7                     | (ASTM D2240) |
| c) Tensile Strength*                                 | minimum 210 psi             | (ASTM D412)  |
| (* main structural areas)                            |                             |              |
| d) Compression deformation                           | 10% at 70psi, 68°F          | (ASTM D575)  |
| e) Brittleness at Low temperature:                   | -40°F                       | (ASTM D746)  |
| f) Freeze and thaw when exposed to deicing chemicals | no loss after 50 cycles     | (ASTM C672)  |
| f) Coefficient of thermal expansion:                 | $8 \times 10^{-6}$ in/in/°F | (ASTM C531)  |
| g) Weathering 70 hours at 158°F                      |                             | (ASTM D573)  |

- hardness retained 100% (± 5%)
- compressive strength 100% (± 5%)
- tensile strength 100% (± 5%)
- elongation retained 100% (± 5%)

3. Available models: 6', 4' and 3' long

4. Basic dimensions and nominal weights as per attached drawings

5. Finishing: Black with reflective yellow, blue or white parallelograms as per attached drawings

Installation methods: a) with spikes 14" long (minimum diameter ½", recommended 5/8")

- 4 spikes for 6' model
- 3 spikes for 4' model
- 2 spikes for 3' model

b) with the lag bolts 6" long with 3" long lead shields (minimum diameter ½", recommended 5/8")

- 4 spikes for 6' model
- 3 spikes for 4' model
- 2 spikes for 3' model

c) with polyurethane adhesive (recommended PL Premium)

- 300 ml. per 6' model
- 200 ml. per 4' model
- 150 ml. per 3' model

Components: a) 100% recycled rubber from car and truck tires (NR, SBR)  
b) polyurethane prepolymer for rubber granules  
c) durable yellow, blue or white reflective tape covered with the glass beads

Attached Drawings: 6' model, drawing No. 34PC02V3  
4' model, drawing No. 22PC02V2  
3' model, drawing No. 17PC02V2-1  
14" rebar spike, drawing No. 05SP01

[www.pittmantraffic.co.uk](http://www.pittmantraffic.co.uk)

21/06/2007

**TOP VIEW**

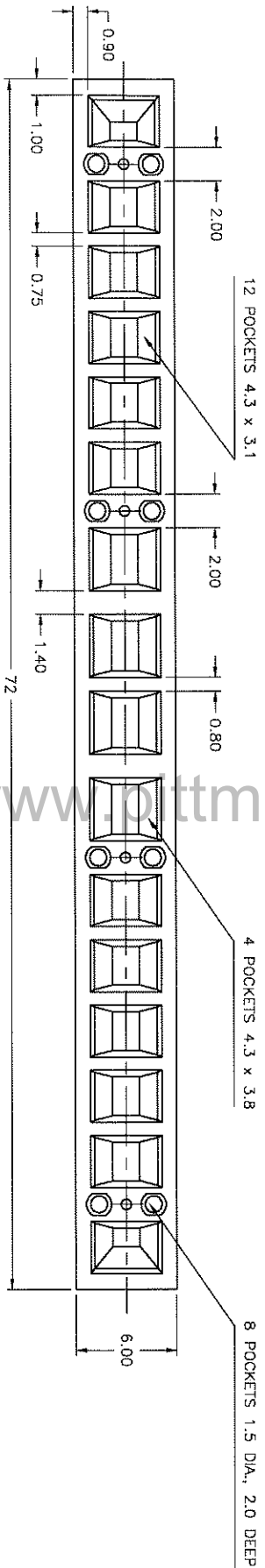
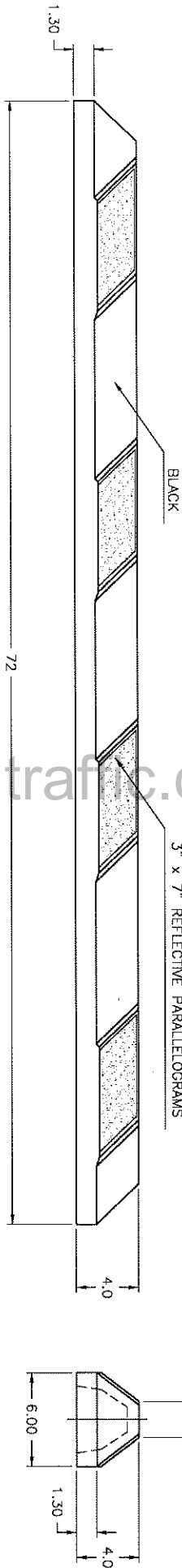
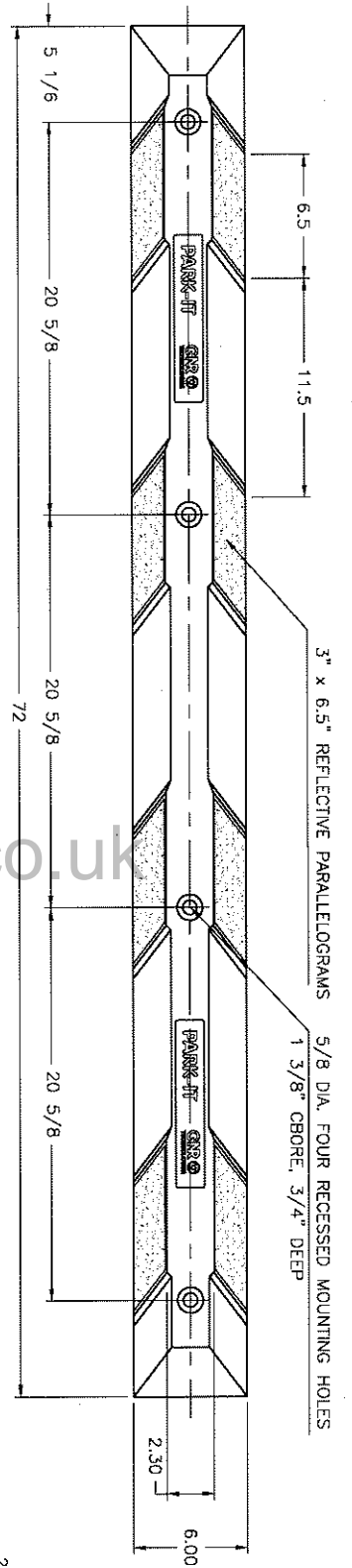

www.gottmantraffic.co.uk

**PRODUCT SPECIFICATIONS:**

1. MATERIAL: COMPRESSION MOLDED RECYCLED RUBBER COMPOSITE
2. NOMINAL DIMENSIONS: 72"L x 6"W x 4"H
3. NOMINAL WEIGHT OF THE PRODUCT: 34 lbs.
4. COLOR: BLACK WITH REFLECTIVE YELLOW, BLUE OR WHITE STRIPES

**GNR TECHNOLOGIES INC.**

**RUBBER PARKING CURB**

**6 FT. MODEL**

UNLESS OTHERWISE SPECIFIED:			
DIMENSIONS ARE IN INCHES			
DECIMALS TOLERANCES		ANGULAR	
.X ± 1/8"		± .05°	
.XX ± 1/16"			
DRAWN	S. JONASZ	DATE	JUL. 26/99
CHECKED	S. JONASZ	DATE	JUL. 26/99
DESIGN	S. JONASZ	DATE	JUL. 26/99
SCALE		1=5	
MATERIAL		DWG NO. 34RC02V3	
		SHEET	
		SIZE	
		C	

THIS DRAWING IS THE PROPERTY OF GNR TECHNOLOGIES INC. AND MAY NOT BE REPRODUCED, PUBLISHED, COPIED TO OTHERS OR USED FOR ANY PURPOSES WITHOUT WRITTEN PERMISSION FROM GNR TECHNOLOGIES INC.

**TOP VIEW**

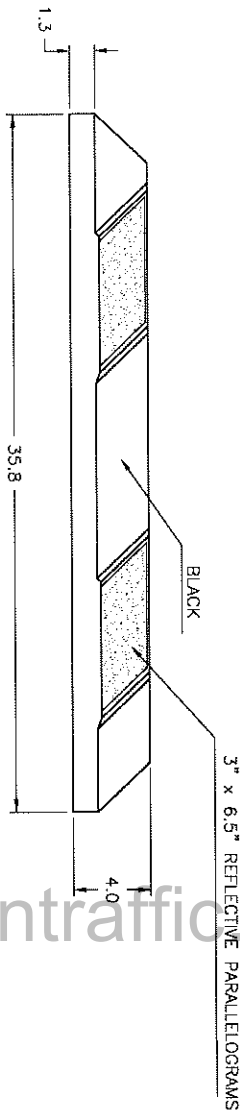
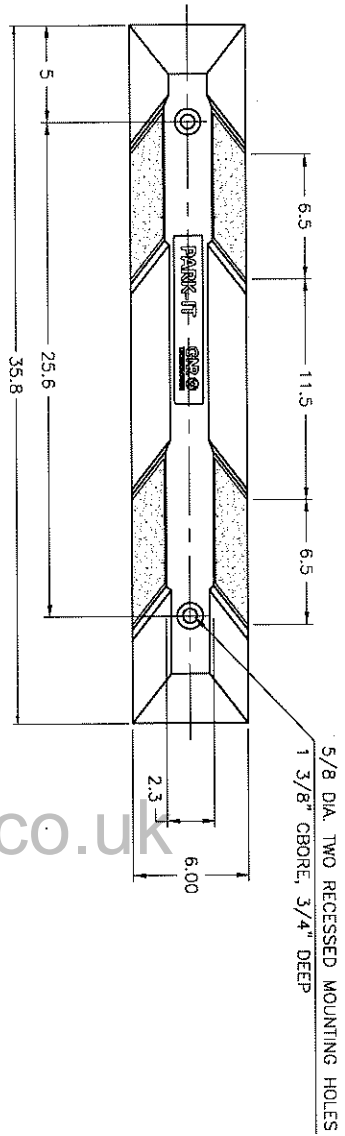

**BOTTOM VIEW**

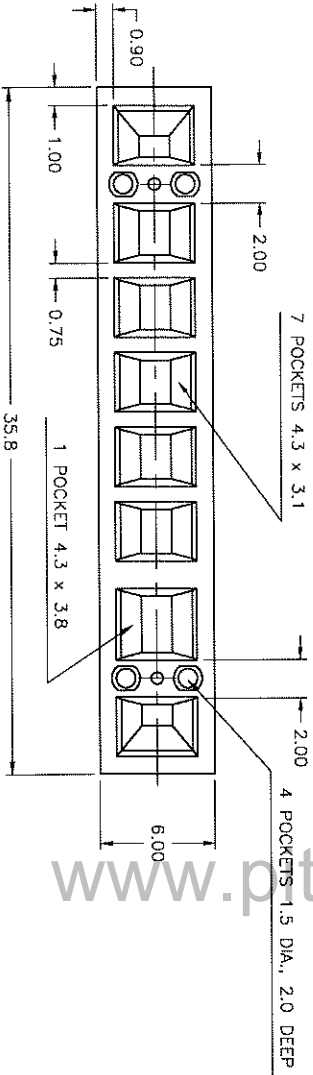

www.pittmantraffic.co.uk

REVISIONS		DATE	APPROVED
REV.	DESCRIPTION		

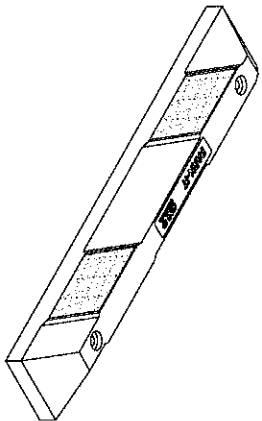
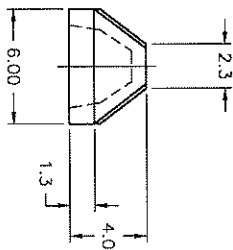

**PRODUCT SPECIFICATIONS:**

1. MATERIAL: COMPRESSION MOLDED RECYCLED RUBBER COMPOSITE
2. NOMINAL DIMENSIONS: 35 3/4" L x 6" W x 4" H
3. NOMINAL WEIGHT OF THE PRODUCT: 17 lbs.
4. COLOR: BLACK WITH REFLECTIVE YELLOW, BLUE OR WHITE STRIPES

**GNR TECHNOLOGIES INC.**

**RUBBER PARKING CURB**  
3 FT. MODEL

UNLESS OTHERWISE SPECIFIED: DIMENSIONS ARE IN INCHES		SCALE 1=5		DWG NO 17PC02V2-2		SIZE C	
DRAWN	DATE	CHECKED	DATE	MATERIAL	SHEET		
S. JONASZ	JUL 26/99	S. JONASZ	JUL 26/99				
DESIGN	DATE	DATE	DATE				
S. JONASZ	JUL 26/99	S. JONASZ	JUL 26/99				

THIS DRAWING IS THE PROPERTY OF GNR TECHNOLOGIES INC. AND MAY NOT BE REPRODUCED, COPIED, OR TRANSMITTED IN ANY FORM OR BY ANY MEANS, ELECTRONIC OR MECHANICAL, WITHOUT WRITTEN PERMISSION FROM GNR TECHNOLOGIES INC.

TOP VIEW

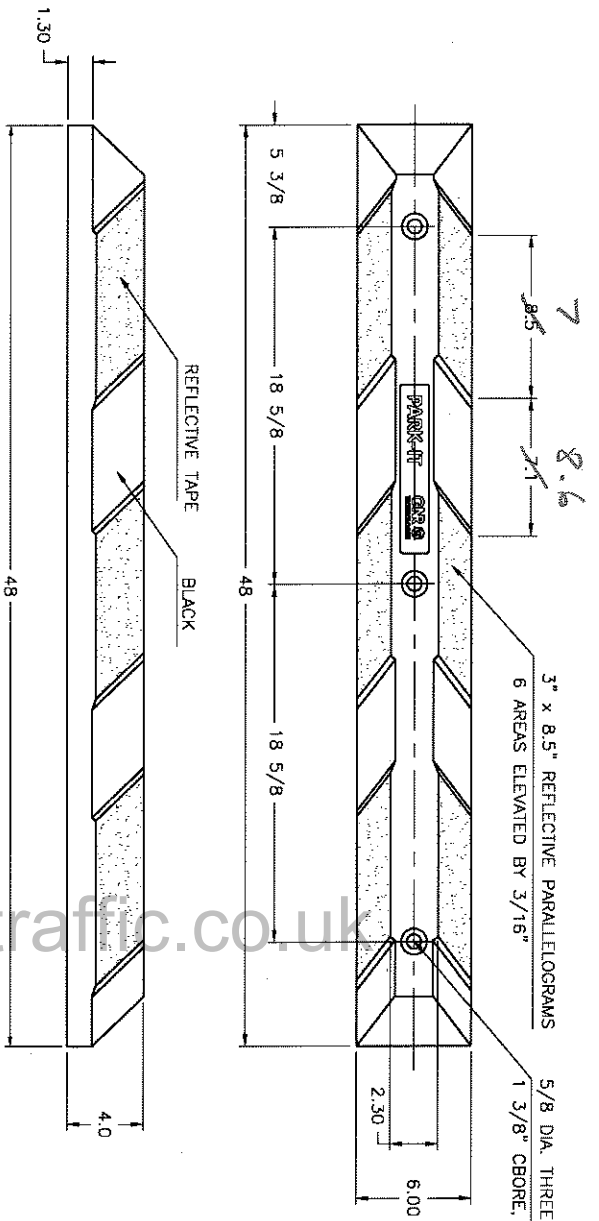

BOTTOM VIEW

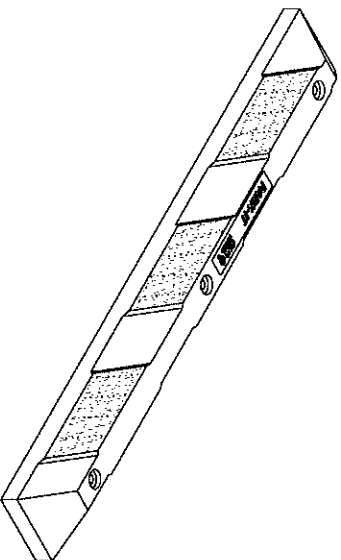
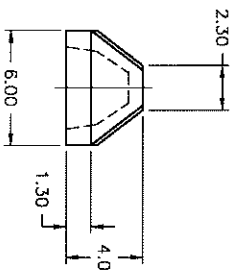
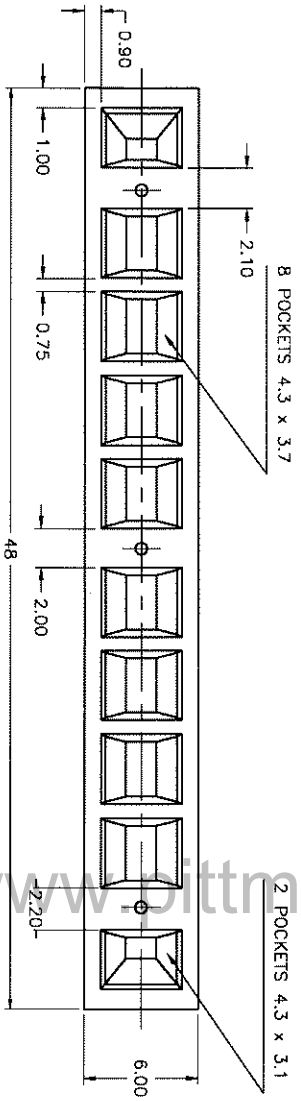

PRODUCT SPECIFICATIONS:

1. MATERIAL: COMPRESSION MOLDED RECYCLED RUBBER COMPOSITE
2. NOMINAL DIMENSIONS: 48"L x 6"W x 4"H
3. NOMINAL WEIGHT OF THE PRODUCT: 22 lbs.
4. COLOR: BLACK WITH REFLECTIVE YELLOW, BLUE OR WHITE STRIPES

GNR TECHNOLOGIES INC.

RUBBER PARKING CURB  
4PT. MODEL

UNLESS OTHERWISE SPECIFIED : DIMENSIONS ARE IN INCHES		SCALE 1=5		DWG NO. 22PC02V2		SIZE C	
DECIMALS .x ± 1/16"	ANGULAR ±.05°	CHECKED S. JONASZ	DATE JUL. 26/99	MATERIAL	SHEET		
DRAWN S. JONASZ		DATE JUL. 26/99					
DESIGN S. JONASZ		DATE JUL. 26/99					

THE DRAWING IS THE PROPERTY OF GNR TECHNOLOGIES INC. AND NOT BE REPRODUCED, COPIED, OR USED FOR MANUFACTURING PURPOSES WITHOUT WRITTEN PERMISSION FROM GNR TECHNOLOGIES INC.

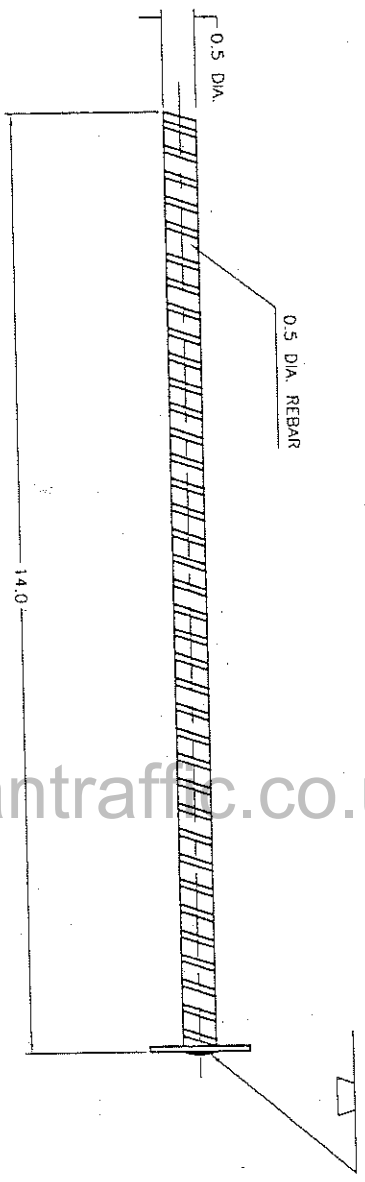

NOTE:

THE WEIGHT OF THE SPIKE: 0.88 LB.

www.pittmantraffic.co.uk

UNLESS OTHERWISE SPECIFIED: DIMENSIONS ARE IN INCHES		DATE: 18/96		GMR TECHNOLOGIES INC.	
TOLERANCES		DATE: 18/96			
DECIMALS	± 0.1	ANGULAR	± 0.5°	0.5" DIA., L=14" REBAR SPIKE	
**	± 0.06		✓		
***	± 0.03				
DRAWN	S.JONASZ	DATE	18/96	SCALE	1=10
CHECKED	S.JONASZ	DATE		DWG NO.	05SP01
DESIGN	S.JONASZ	DATE	18/96	MATERIAL	STEEL
		REV.			

THIS DRAWING IS THE PROPERTY OF GMR TECHNOLOGIES INC. AND MAY NOT BE DUPLICATED, PUBLISHED, DISCLOSED TO OTHERS NOR USED FOR MANUFACTURING PURPOSES WITHOUT WRITTEN PERMISSION FROM GMR TECHNOLOGIES INC.