

EN 12453  
EN 12445  
COMPLIANT

## FIELD 250/ 600

ELECTROMECHANICAL UNDERGROUND OPERATORS FOR SWING GATES

Max gate leaf length - 3500 mm  
Max gate leaf weight - 250/600 kg

### Features

- **Electromechanical** underground operator for swing gates with 4 versions available (*Field 250kg, Field 600kg oil, 24Vdc & Fast*).
- **Lubricated gear boxes** in all motors (*250 - Grease Filled / 600 - Oil Filled for enhanced performance*).
- **Adjustable mechanical stops** in opening and closing (*Field 250 - optional / Field 600 - standard*).
- **Universally handed** motors for ease of installation.
- **Stainless steel** foundation boxes and 180 degree **conversion kits** available.
- **Heavy duty** foundation box capable of supporting gates up to 600 Kg.

### Advantages

- **Engineered** to a very high standard to provide reliability & durability.
- **Opening time of 18 secs** with a high speed option available.
- **Strengthened gears** on Field 600 to allow for higher loads.
- **Double worm drive** system for motor protection and increased power.
- **Manual release systems** that are easy to use - **lever handle** as standard / **key locking** system (*added security*) optional extra.
- **Electronic soft stop** eliminates noise at end of travel and reduces stresses on solid flexible gates, preventing foundation box distortion and any future alignment problems.

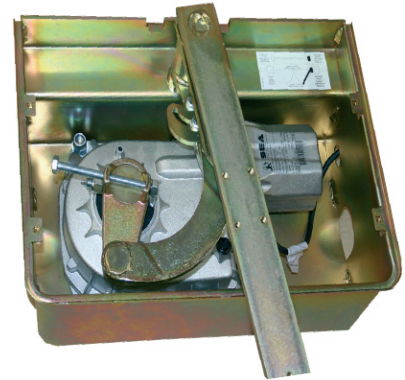

Toughened internal gears  
double worm drive  
(Field 600 pictured)

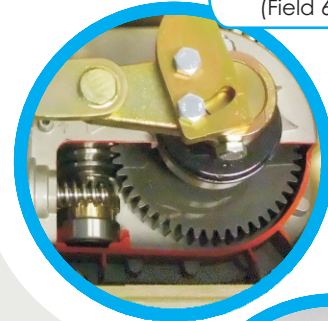

Optional Key release

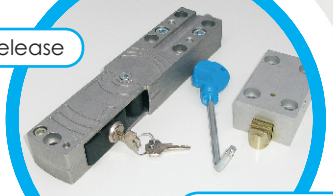

Standard release  
with lever



Open stop on Field 600  
Optional on Field 250

**“Where quality matters, ask for  
SEA - the Engineers’ choice!”**

#### SEA (UK) Limited

##### Midlands Head Office:-

Unit 2 Ardath Road, Kings Norton,  
Birmingham, West Midlands, B38 9PJ  
Tel: 0121 433 3348 / Fax: 0121 433 5695

##### London Trade Counter:-

1-4 Grange Mews,  
Rear of 28 The Grangeway,  
LONDON N21 2HG  
Tel: 020 8360 8022 / Fax: 020 8364 2516

[sales@seauktd.co.uk](mailto:sales@seauktd.co.uk) / [www.seauktd.co.uk](http://www.seauktd.co.uk)

**SEA (UK) LIMITED**

**Field 250 / 600**

Specifications	250	600	fast	600 24V
Supply voltage	230V +5% 50/60Hz			
Motor power	280 W	310 W	380 W	150 W
Max leaf weight	250 kg	600 kg	300 kg	600 kg
Cycles hour	15cy/hr	20cy/hr	20cy/hr	50cy/hr
Operating temperature	-20°C + 55°C			
Operator weight	12 kg	12.5 kg	12.5kg	12.5kg
Max leaf length	2.5 m	3.5 m	1.6 m	3.5 m
Opening degrees	110°-180°			
Working time 90°	18 sec	18 sec	9 sec	14-30 sec
Protection class	Ip67			
Starting capacitor	10 uF	12.5 uF	10 uF	n/a
Max pushing force	250 Nm	300 Nm	200 Nm	300 Nm

**CONTROL BOARD - Specifications**

**GATE 2 - 230V**

- Management of two 230V motors with or without limit switch
- Automatic logic (4 modes)
- Slow down in opening and closing
- Motor torque adjustment
- Self-learning operating times
- Auto-test on photocells
- Auto-diagnostic
- Rotation sensing by combining with patented Safety Gate
- Electric lock management
- Diagnostic LEDs on all outputs/inputs
- Extractable connectors
- Inbuilt radio control system for rolling code and Ecopy

**Field Dimensions (mm)**

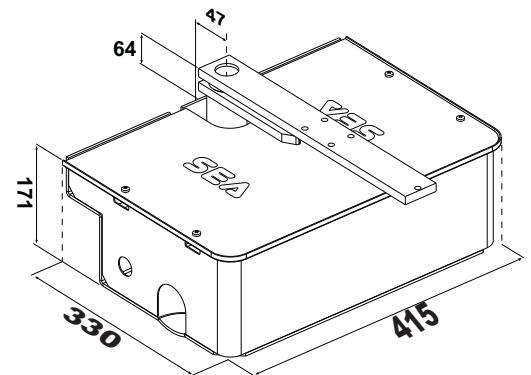

**Accessories to Enhance your System:-**

- Loop detectors
- Photocells
- Keypads
- Card readers
- Transmitters and receivers
- Telephone entry systems
- Audio and video intercom systems (wireless and cabled)
- Vehicle recognition systems
- Biometric identification systems
- Patented mechanical safety edges (wireless and cabled)
- Time clocks
- Hold open switches

**Gate leaf weight to length ratio**

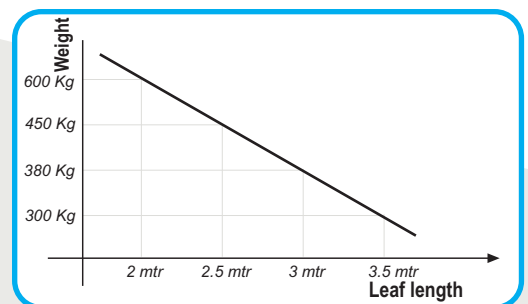

**SEA SAFETY GATE:-**  
Patented reversing system for swing gates with a self learning movement sensor for additional safety.  
En12453 & EN 12445 tested.



**Long Range**



**High Security**

**Solar Powered Photocells**