



# ENVIROGRAF®



## PASSIVE FIRE SEALS FOR CARPENTERS & GENERAL BUILDERS



MEMBER OF  
THE FIRE  
PROTECTION  
ASSOCIATION



INTUMESCENT SYSTEMS LTD, ENVIROGRAF HOUSE,  
BARFRESTONE, DOVER, KENT, CT15 7JG, UK  
PHONE: +44 (0) 1 304 842 555  
FAX: +44 (0) 1 304 842 666  
EMAIL: sales@envirograf.com



## FIRE RATED OPENINGS

A range of fire rated ventilation grilles for doors, fire rated letterboxes and magnetic door holding systems. Everything required to help ensure the fire integrity of fire doors and glazing areas and maintain the safety of the means of escape.

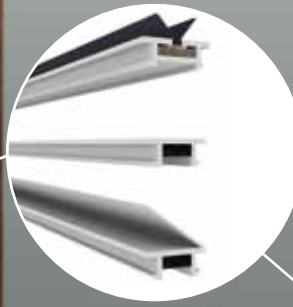

**PRODUCT 100**  
Push Fit Fire and  
Smoke Seals  
**P22-23**

## DESIGNED FOR FIRE DOORS

The products designed for fire doors include a comprehensive range of intumescent fire door seals including our new unique 'clip-in' door seal for simple, rapid installation and for ease of use during redecoration.



**PRODUCT 36**  
Intumescent Block Grilles **P9**

# KEEP PEOPLE SAFE

## Maintain the means of escape

**Envirograf® – one of the most extensive range of fire seals for use with fire doors and glazing systems. Helping to keep the means of escape safe in all building designs.**

The design of any building must include effective escape routes that allow all occupants to evacuate to safety if a fire were to occur. Escape routes depend on the ability of certain building elements to hold back a fire in the area in which it has started, helping to separate it from the corridors and open areas that are part of the means of escape.

### Openings in compartmentation

All rooms that are designed as fire compartments have openings: windows, doors, air ventilation systems as well as small penetrations for electrical and plumbing systems. All of these openings must include fire rated elements that are equal to the fire rating of the compartment room. If for example the room is expected to contain a fire for 60 minutes then all doors, glazing units, air ventilation grilles and service penetrations must also have 60 minute fire rating.

Envirograf® have designed a unique set of fire seals that are specifically designed to maintain the fire integrity of compartment openings. In this brochure we have included the product range that is specific to fire doors and glazing areas.

The products designed for fire doors include an exciting range of intumescent fire door seals including our new unique 'clip-in' door seal for ease of use at the installation stage and when redecorating is required.

There is a range of ventilation grilles for doors, fire rated letterboxes and magnetic door holding systems, everything required to help maintain the fire integrity of fire doors and glazing areas and the safety of the means of escape. Keeping people safe in the event of a fire!

## FIRE SEALS FOR DOORS & GLAZING

Envirograf® have designed a unique set of fire seals that are specifically designed to maintain the fire integrity of compartment openings. In this brochure we have included a product range specific to fire doors and glazing areas.



**PRODUCT 79**  
Glazing Bead System P20

## SECTION 5 OF DOCUMENT B OF THE UK BUILDING REGULATIONS STATES

**5.1** The spread of fire within a building can be restricted by sub-dividing it into compartments separated from one another by walls and/or floors of fire-resisting construction.

The object is twofold:

- a** To prevent rapid fire spread which could trap occupants of the building; and
- b** To reduce the chance of fire becoming large, on the basis that large fires are more dangerous, not only to occupants and fire and rescue service personnel, but also to people in the vicinity of the building.
- c** Compartments are crucial to the success of the means of escape and it is therefore crucial that all the building elements used as part of the compartment structure are fully fire rated according to the appropriate Building Regulations.

# Contents

|                    |   |       |
|--------------------|---|-------|
| <b>Product 14</b>  | Intumescent fan covers  | 06    |
| <b>Product 34</b>  | Intumescent fire and smoke grilles  | 07    |
| <b>Product 35</b>  | MG and MGL Intumescent grilles  | 08    |
| <b>Product 36</b>  | Intumescent block grilles   | 09    |
| <b>Product 43</b>  | Magnetic timed door holder  | 10    |
| <b>Product 49</b>  | Intumescent letter flap system  | 11    |
| <b>Product 50</b>  | Intumescent liner for mail apertures                                      | 12    |
| <b>Product 52</b>  | Intumescent metal fire box and flexible fire bag                          | 13    |
| <b>Product 68</b>  | Rebated intumescent fire seals  | 14    |
| <b>Product 69</b>  | Surface-mounted intumescent fire and fire/smoke seal                      | 15    |
| <b>Product 70</b>  | Replacement hardwood door edging  | 16    |
| <b>Product 71</b>  | Hinge lock, door closer protection and Intuplug® intumescent fixing plugs | 17    |
| <b>Product 76</b>  | Rebated intumescent fire and smoke seals with aluminium holder            | 18    |
| <b>Product 78</b>  | Envirostrip   | 19    |
| <b>Product 79</b>  | Glazing bead system for fire doors and screens                            | 20    |
| <b>Product 97</b>  | Door stop with intumescent fire seal and brush or neoprene smoke seal     | 21    |
| <b>Product 100</b> | Rebated intumescent fire and fire/smoke seals                             | 22-23 |
| <b>Product 108</b> | Door edge protective trim   | 24    |
| <b>Product 109</b> | Intumescent glazing channels  | 25    |
| <b>Product 116</b> | Protector for etched or stained glass                                     | 25    |
| <b>Product 118</b> | Animal door flap protector  | 26    |
| <b>Product 130</b> | Fire-protected security door viewer                                       | 27    |
| <b>Product 133</b> | AVG/F Acoustic/fireproof ventilation grille                               | 28    |
| <b>Product 103</b> | Upgrading raised & fielded door system                                    | 29-30 |
| <b>Product 38</b>  | Upgrading system for existing panelled doors to FD 30 - 60 fire rating    | 31-32 |

# Envirograf® Fire Door Protection Products

Keeping Fire Doors Effective!

The role of the fire door is one of the most important elements of fire protection in a building. Its effectiveness in resisting flames and smoke helps to prevent a fire from spreading, thus saving property and lives by allowing time for the occupants to escape. This is particularly important in multiple occupancy housing, retirement homes, maisonettes, apartments, etc.

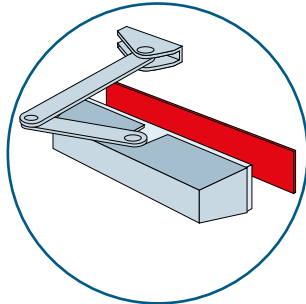

**PRODUCT 71**  
Door closer protection **P17**



**PRODUCT 79**  
Glazing bead system for fire doors and screens **P20**



**PRODUCT 109**  
Intumescent glazing channels **P25**

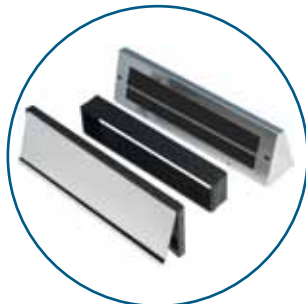

**PRODUCT 49**  
Intumescent letter flap system **P11**

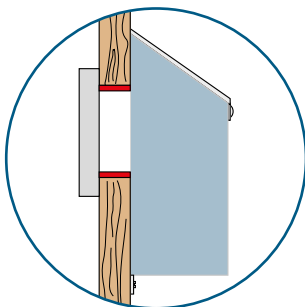

**PRODUCT 52**  
Intumescent metal fire box and flexible fire bag **P13**

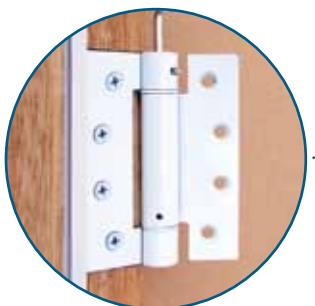

New self-closing hinge set of 3 **P17**

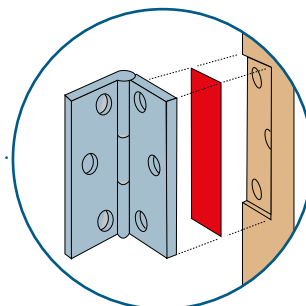

**PRODUCT 71**  
Hinge protection **P17**

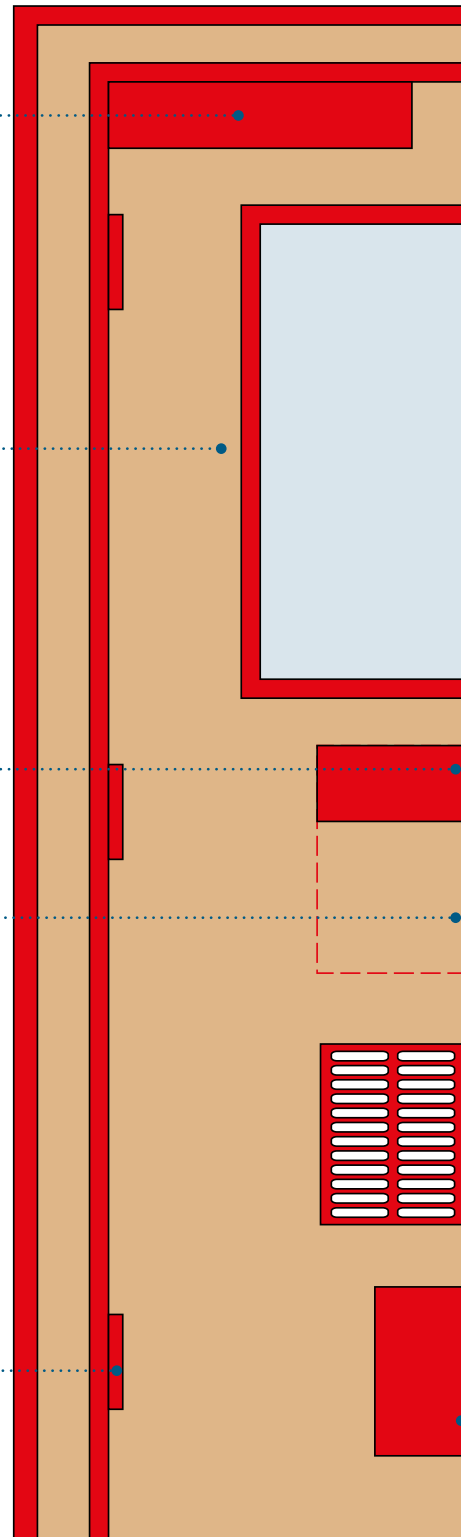

The fitting of a fire door is more complex than it seems. For example, a fire door must have intumescent material around either the door edge or the frame. Smoke seals should be fitted, and the door furniture should be installed with fire protection in mind.

Despite the British Standard 5588 Part 31/1 and Document B of UK Building Regulations, which clearly states the required specifications of a fire door set, fire officers are constantly finding doors with items fitted that have no fire protection qualities, thus completely removing the door's fire integrity, e.g. letter boxes,

hinges, locks, and cat and dog flaps. If a fire should occur, these doors would be ineffective and could lead to the loss of life.

The Envirograf® range of products has been designed to maintain the integrity of the fire door, particularly doors used in houses of multiple occupancy. All of the products have been produced with cost-effectiveness and ease of installation in mind, and they have been tested to the relevant British Standards. For 'listed' buildings, old doors can be upgraded to fire-rated doors by utilising Envirograf® Products 38 and 42. See pages 29-32.

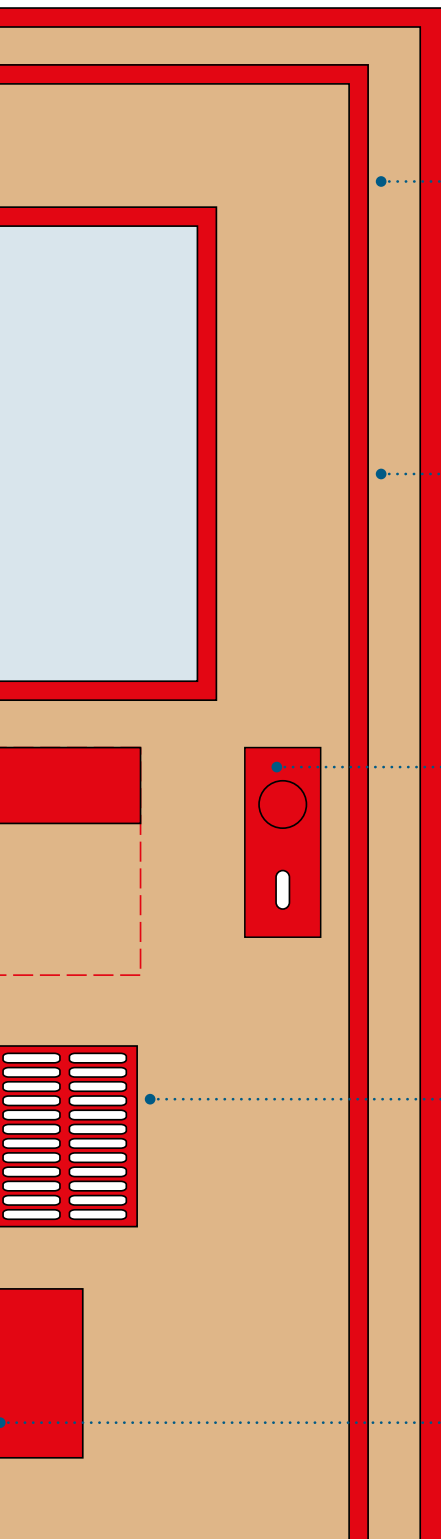

**PRODUCT 100**  
New push fit fire  
and smoke seals **P22 - 23**



**PRODUCT 69**  
Surface mounted fire and smoke seals **P15**

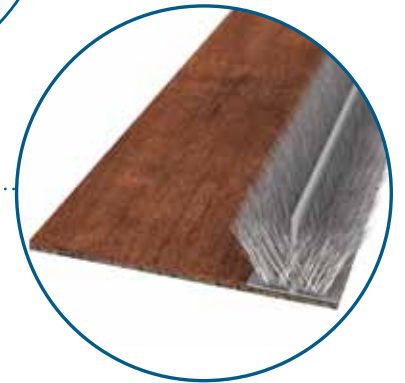

**PRODUCT 71**  
Lock protection **P17**

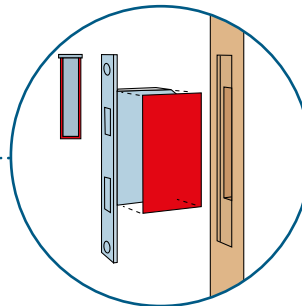

**PRODUCT 35**  
MG and MGL  
intumescent grilles **P8**



**PRODUCT 118**  
Animal door flap protector **P26**

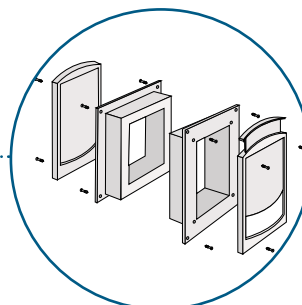









**PRODUCT 36**  
New all in one block grille  
for doors and walls **P9**

## CHOOSING THE RIGHT SEAL FOR FIRE DOORS

All fire doors must have intumescent and smoke seals. Fire doors have a colour coding system that states the seal requirements, see table below.

### COLOUR CODING SYSTEM

| Seal requirement  | Seal requirement  |
|---|---|
|  Intumescent |  Smoke |
|  Intumescent |  Smoke |
|  Intumescent |  Smoke |
|  Intumescent |  Smoke |

Blue or red centre dot means intumescent must be fitted according to manufacturer's instructions. Smoke seals must also be fitted to meet BS 476 part 31/1

Green centre dot means intumescent is already fitted. Smoke seals must also be fitted to meet BS 476 part 31/1

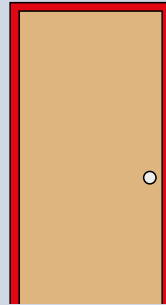

### SURFACE FITTING REQUIRED

Seals can be fitted either into the edge of the door or into the frame, shown by the red line in the adjacent illustration.

### GAPS REQUIRED

Rebated seals: 4 - 4½mm to allow for neoprene seals or brushes which are 5 - 5½mm in length Surface-mounted seals: 3mm upwards.

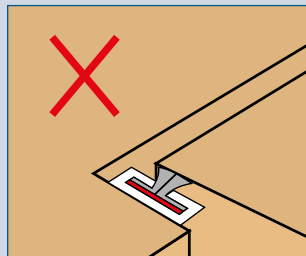

### DOOR STOPS

For Fire doors with up to 185 minutes rating, stops can be 12mm or less and only need to be pinned - not glued.

## PRODUCT 14 INTUMESCENT FAN COVERS

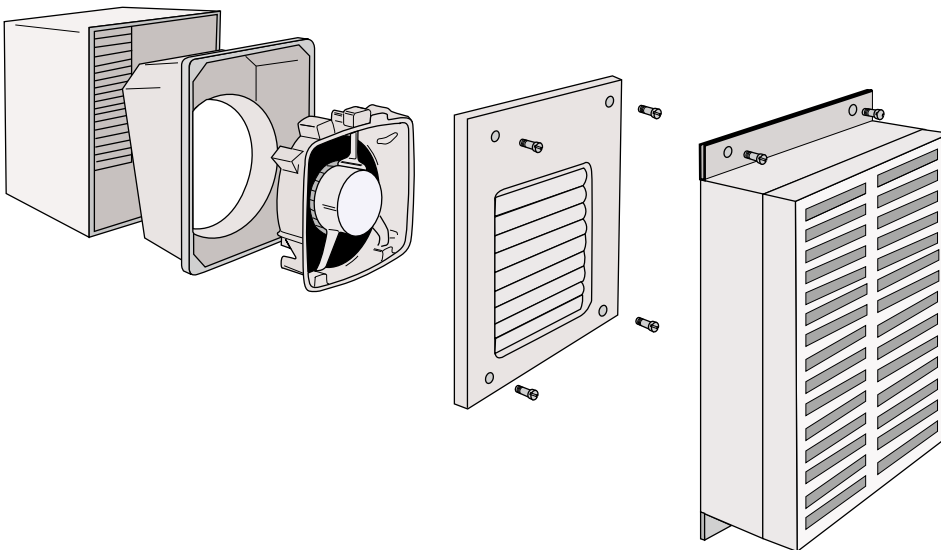

- An intumescent grille unit available in two types: wall mounted and glass mounted

### USE

Fan cover units can be installed over VentAxia, Xpelair, or other makes of wall or window fans, giving fire and smoke protection to escape corridors and staircase fire escapes.



### FIRE TEST PERFORMANCE

|                              |                   |
|------------------------------|-------------------|
| BS476 Parts 20 and 22 (1987) | 73 min            |
| EN1363-1 (2000)              | European Standard |

### ORDERING REFERENCES

| Ref        | Description   |
|------------|---------------|
| <b>FCW</b> | Wall-mounted  |
| <b>FCG</b> | Glass-mounted |

### Add suffix for

|           |  |
|-----------|--|
| <b>/X</b> | <b>Xpelair</b> plus the model, catalogue number, fan size  |
| <b>/V</b> | <b>VentAxia</b> plus the model, catalogue number, fan size |

When ordering fan covers, please allow a minimum 35mm clear gap around the fan mouldings for ease of fixing and wiring. Please supply the depth of fan when ordering.

# PRODUCT 34 INTUMESCENT FIRE AND SMOKE GRILLES

- Smoke protection grilles for openings in walls, ceilings and fire doors or at the entry point of ventilation ducting
- Full fire and smoke protection



● smoke alarm system

● automatic heat switch system

● The TJ Grille automatically closes when activated by either the smoke alarm system or an automatic heat switch system

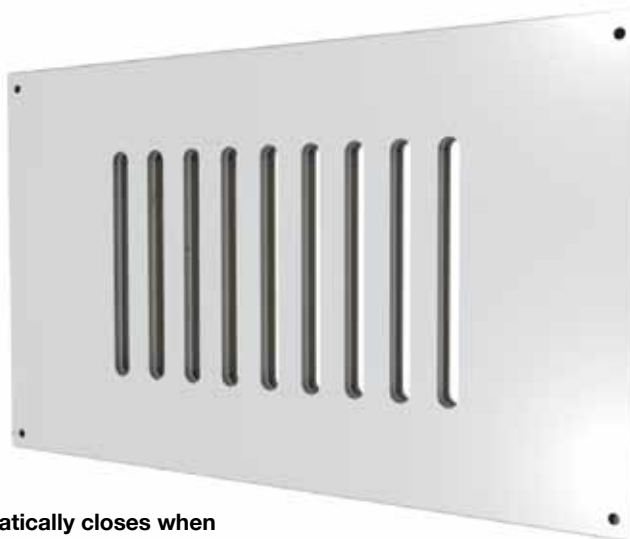

## USE

The TJ grille can be either installed into an existing 24V fire/smoke alarm system or (alternatively, if there is no alarm system available or the grille is required to be independent), into an Envirograf® AC mains to 24V control unit with smoke detector circuit and N/O or N/C contacts. This control unit can operate up to 3 grilles.

## FIRE TEST PERFORMANCE

|                      |        |
|----------------------|--------|
| BS476 Part 20 (1987) | 66 min |
| BS476 Part 22 (1987) | 73 min |

## RE-SETTING OPTIONS FOR THE TJ GRILLE

- 1 Manual re-set (by hand, with a screwdriver or knife) with a permanent loading of 125mA 24V.
- 2 An automatic re-set grille with a permanent loading of 125mA, with a re-set loading of 6A 24V for a period of 1 second.
- 3 A nonelectrical grille containing a thermal breaker that automatically activates at between 60 and 70°C, moving the shutter to the closed position.
- 4 A nonelectrical grille containing a memory spring device that operates in the temperature range 50°C to 65°C, closing the shutter to fire and smoke in about 47 seconds.

Also available are TJ grilles that open when activated by the fire alarm system, to allow smoke to escape into designated outlets.

## ORDERING REFERENCES

| Ref  | Internal Hole Size Height x Width | External Size Height x Width |
|------|-----------------------------------|------------------------------|
| NTJ1 | 140 x 280mm                       | 200 x 340mm                  |
| NTJ2 | 240 x 280mm                       | 300 x 340mm                  |
| NTJ3 | 190 x 305mm                       | 250 x 365mm                  |
| NTJ4 | 270 x 305mm                       | 325 x 365mm                  |
| NTJ5 | 340 x 380mm                       | 400 x 440mm                  |
| NTJ6 | 390 x 430mm                       | 450 x 490mm                  |
| NTJ7 | 390 x 505mm                       | 450 x 565mm                  |
| NTJ8 | 290 x 580mm                       | 350 x 640mm                  |

References shown for manual reset grilles only. Other grilles made to order.

| Add suffix for |                      |
|----------------|----------------------|
| /A             | Auto reset grille    |
| /MS            | Memory spring grille |
| /TL            | Thermal break grille |

TJ Grilles are available with the following optional extras

|       |   |
|-------|---|
| CTJ1  | A control unit supplying up to 3 grilles (2 if the grilles are larger than 400x400mm and 1 if over 500x500mm)<br>With a smoke detector circuit with N/O or N/C terminals for AC mains to 24V supply |
| SG/S  | Smoke detector and base for use with the CTJ1 Control Unit  |
| SG/CB | A control unit with a battery back-up and charger to keep the grille open in a 24 volt power failure  |

**PRODUCT 35 MG AND MGL INTUMESCENT GRILLES**

**MGL - NON VIEWING**



**MG - VIEWING**

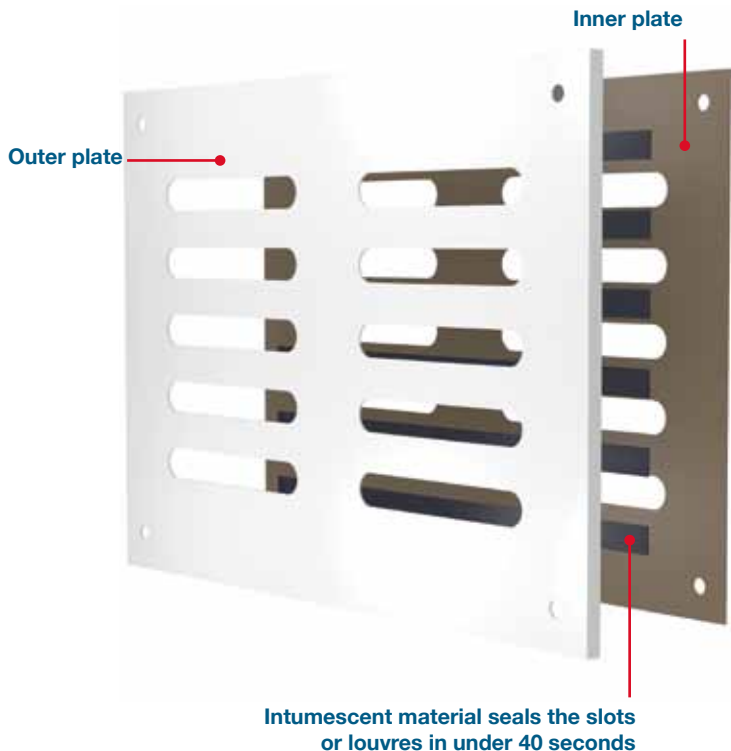

- 2 types of intumescent ventilation grille giving up to 73 minutes of fire protection
- MG is slotted for viewing giving approximately of 6cm<sup>2</sup> free ventilation area
- MGL is louvred, nonviewing giving 3.2cm<sup>2</sup> of free ventilation area
- Used for both sides of doors and walls - internally, externally and on ceilings
- Finished in brown, white, stainless steel and polished brass
- Other sizes and colours are made to order

**USE**

These grilles are used for both sides of doors and walls. Two types of plate are supplied: type MG is slotted for more ventilation and type MGL is louvred, non viewing. The grilles are finished in brown, white, stainless steel and polished brass finish. Other sizes and colours are made to order. Each slot gives approximately 6cm<sup>2</sup> and each louvre gives 3.2cm<sup>2</sup> free ventilation area. Can be used internally, externally and on ceilings.

- Insect fly screen mesh can be supplied for fixing behind the grille face for sterile work areas



**ORDERING REFERENCES**

|                      |  |
|----------------------|--|
| <b>MG &amp; MGL</b>  | Available in 13 standard sizes (other sizes made to order)         |
| <b>MG/S or MGL/S</b> | For standard doors or walls requiring protection to risk side only |
| <b>MG/D or MGL/D</b> | For doors or walls requiring protection on both sides              |

**FIRE TEST PERFORMANCE**

|                              |                   |        |
|------------------------------|-------------------|--------|
| BS476 Parts 20 and 22 (1987) | On one side only  | 66 min |
| BS476 Part 22 (1987)         |                   | 73 min |
| EN1363-1 (2000)              | European Standard |        |



**NEW BG-GRILLE**



- The new elegantly designed BG grill
- Single or double grille face options
- Combined with a powerful intumescent section, that fits into the door aperture



**ORIGINAL BG-GRILLE**



- A slim block-type intumescent grille giving an excellent free ventilation area
- For ceilings, doors, walls and ventilation ducting
- Openings are sealed off in under one minute when attacked by fire
- Can be made as shallow as 15mm deep to special order

**USE**

These grilles are used in ceilings, doors, walls and ventilation ducting. These grilles have been designed for simple installation whilst also offering excellent fire protection. They are manufactured using high quality steel guaranteeing years of use.

**ORDERING REFERENCES**

|            |   |
|------------|---|
| <b>BG</b>  | Original Style – sizes from 50mm to over 1000mm (plus specials) |
| <b>NBG</b> | New Style – sizes from 100mm to 300mm                           |



**FIRE TEST PERFORMANCE**

|                      |                   |
|----------------------|-------------------|
| BS476 Part 22 (1987) | 240 minutes       |
| EN1363-1 (2000)      | European Standard |

**PRODUCT 43 MAGNETIC TIMED DOOR HOLDER**

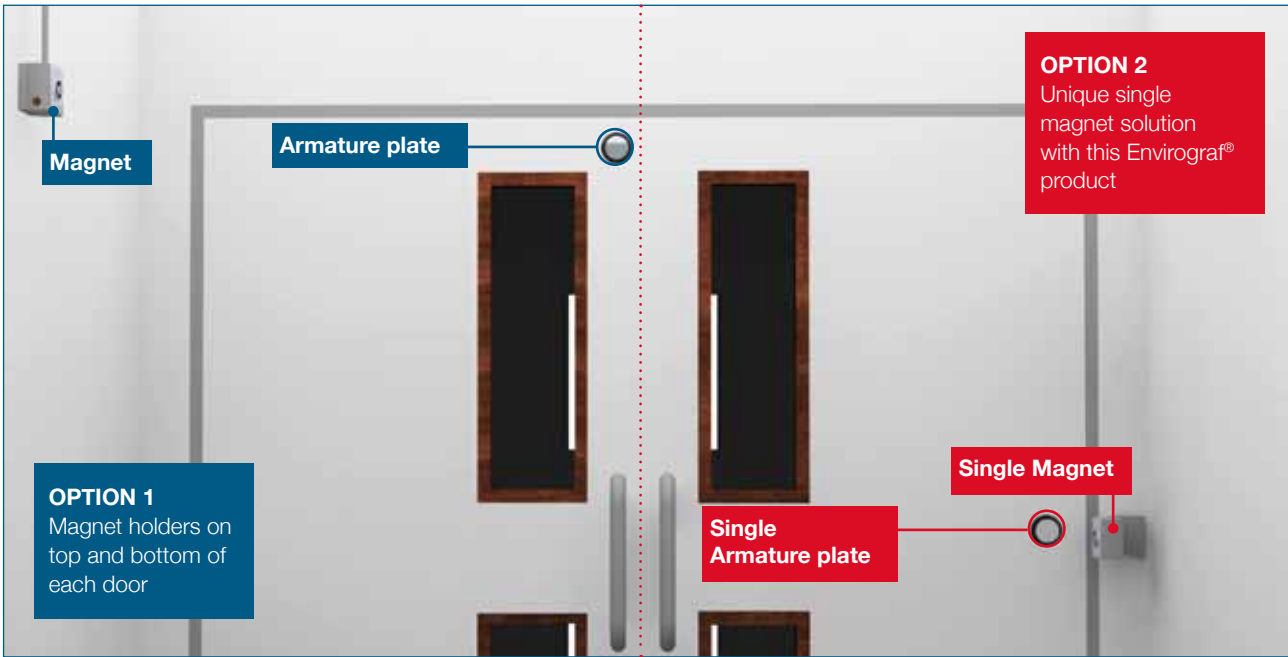

- An electromagnetic timed door holder
- Operates independently of existing fire alarm system
- Master unit for mains voltage in and 24V out
- Electromagnet and armature plate
- Units are available for single doors, double doors

- Envirograf® magnetic timed door holders have been installed in many hospitals, clinics, schools and colleges as well as other public buildings throughout the UK. Product 43 is one of the simplest magnetic door holding systems to install, offering many years of use in high pedestrian traffic areas

**USE**



Designed to hold open single or double doors from 20-57 seconds, cutting down on draughts, noise and loss of heat, as well as preventing buckling and distortion of doors, a common problem with permanent door holders.

The 24V electromagnet releases the door to be shut by the door closer as usual. Ideal for hospitals, residential homes, offices, computer suites, hotels and warehouses.

Can be supplied for operation by blind people. Holds the door open until the person has passed through the opened doorway.

No wiring to existing fire alarm system as agreed by the fire brigade, because duration of door opening is under one minute.

**ORDERING REFERENCES**

|       |  |
|-------|--|
| MHK1  | Kit for one door<br>1 control, 1 magnet, 1 plate             |
| MHK2  | Kit for two doors<br>1 control, 2 magnets, 2 plates          |
| MH24  | 24V magnet and armature<br>Parts can be supplied separately  |
| MH240 | 240V magnet and armature<br>Parts can be supplied separately |
| SGC/2 | Control unit only (if required separately)                   |
| MDHB  | Bracket for fixing magnetic door holder to wall              |

Accepted by fire brigades and building control officers

**PRODUCT 49 INTUMESCENT LETTER FLAP SYSTEM**



**LETTERBOX OPTION 1**  
 ● including internal security lock



**LETTERBOX OPTION 2**  
 ● including internal security lock and key holder system

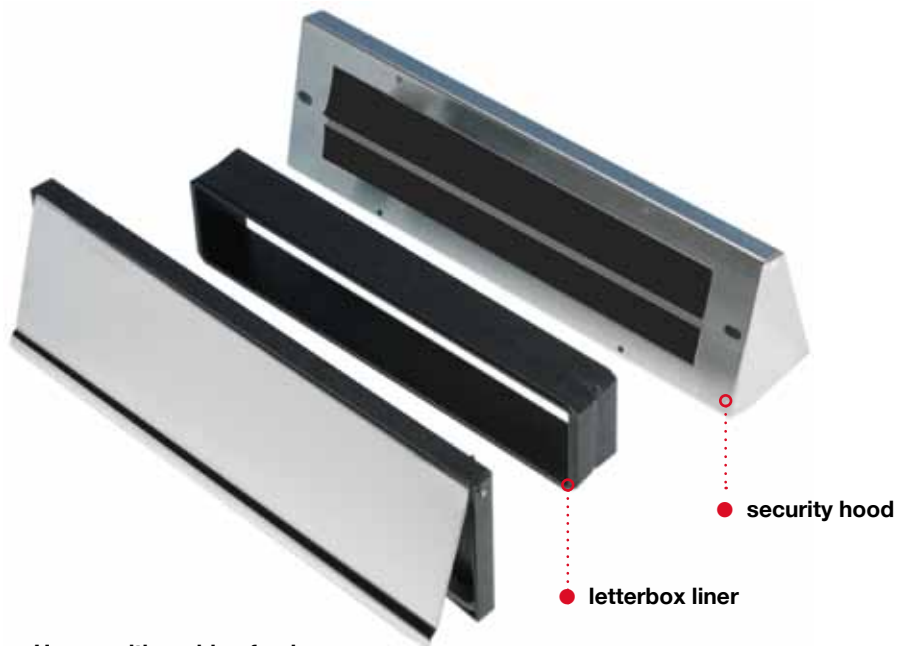

- Use on either side of a door
- Intumescent liner to fix into the door aperture
- All letter box systems are supplied with fixing screws
- Intumescent fire and smoke protection letter flap system
- Frame fitted with smoke protection seal and spring-loaded flap
- Security hood or lockable letter plate (LLP – W 50mm x H 267mm) can be supplied as internal alternatives to fit to the door

**KIT A**

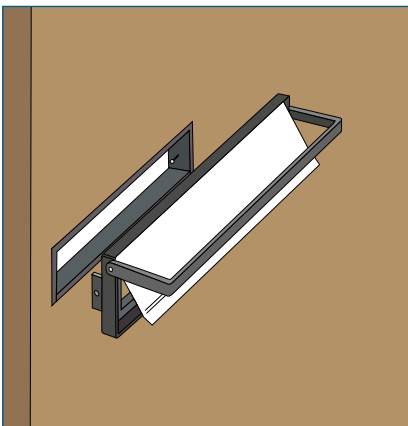

| L1-L4 types   |          |
|---------------|----------|
| Cut hole size | 50x267mm |
| Overall size  | 75x315mm |

**Product Kit 1**  
 1x Front frame and flap  
 1x Intumescent liner

**KIT B**

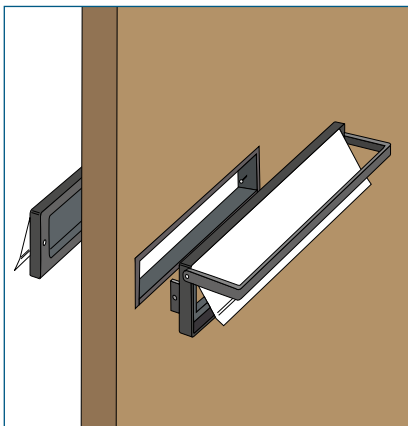

| L6-L8 types   |           |
|---------------|-----------|
| Cut hole size | 69x290mm  |
| Overall size  | 100x335mm |

**Product Kit 2**  
 1x Front frame and flap  
 1x Intumescent liner  
 1x Rear frame and flap

**KIT C**

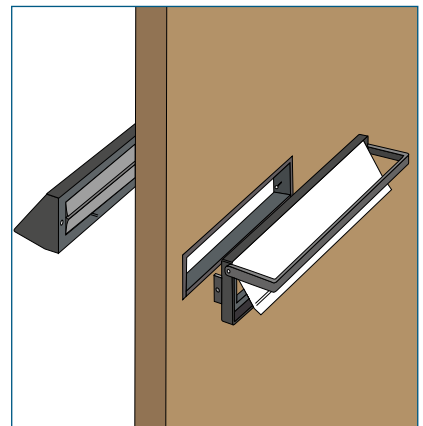

| L9-L12        |           |
|---------------|-----------|
| Cut hole size | 100x350mm |
| Overall size  | 120x390mm |

**Product Kit 3**  
 1x Front frame and flap  
 1x Intumescent liner  
 1x Rear security hood

**FIRE TEST PERFORMANCE**

|                      |  |        |
|----------------------|--|--------|
| BS476 PART 22 (1987) | Built into a composite door, maintaining the integrity of the door | 61 min |
| EN1634-1 (2000)      | European Standard  | 68 min |

**SEE PAGE 12 FOR ORDERING REFERENCES**

## ORDERING REFERENCES

|              |  |
|--------------|--|
| <b>Kit A</b> | Front frame and flap<br>Intumescent liner                        |
| <b>Kit B</b> | Front frame and flap<br>Intumescent liner<br>Rear frame and flap |
| <b>Kit C</b> | Front frame and flap<br>Intumescent liner<br>Rear security hood  |

| Finish           | Ref  | Ref  | Ref  |
|------------------|------|------|------|
| <b>Coloured*</b> | L6/A | L6/B | L6/C |
| <b>Stainless</b> | L7/A | L7/B | L7/C |
| <b>Brass</b>     | L8/A | L8/B | L8/C |

\*Coloured: black, brown, fawn, or white. BS and RAL colours are made to order at extra cost

| Finish           | Ref  | Ref  | Ref  |
|------------------|------|------|------|
| <b>Brown</b>     | L1/A | L1/B | L1/C |
| <b>White</b>     | L2/A | L2/B | L2/C |
| <b>Stainless</b> | L3/A | L3/B | L3/C |
| <b>Brass</b>     | L4/A | L4/B | L4/C |

BS and RAL colours are made to order at extra cost

| Finish           | Ref   | Ref   | Ref   |
|------------------|-------|-------|-------|
| <b>Brown</b>     | L9/A  | L9/B  | L9/C  |
| <b>White</b>     | L10/A | L10/B | L10/C |
| <b>Stainless</b> | L11/A | L11/B | L11/C |
| <b>Brass</b>     | L12/A | L12/B | L12/C |

BS and RAL colours are made to order at extra cost

### INTERNAL SMOKE FLAP

Comprising 10mm deep metal surround with a metal flap, housing a smoke and draught seal to suit aperture size 50x267mm, available in the following standard finishes:

| Ref         | Finish                |
|-------------|-----------------------|
| <b>SM/S</b> | Black, brown or white |
| <b>SM/S</b> | Stainless Steel       |
| <b>SM/S</b> | Brass                 |

### LOCKABLE INTERNAL LETTER FLAP

Similar to the internal smoke flap above, except that the flap has a twist-action catch fitted to help keep out undesirable materials such as fireworks, junk mail, etc. Items LLP3 & LLP4 are lockable internal letter flaps with key holder.

| Ref         | Finish                |                 |
|-------------|-----------------------|-----------------|
| <b>LLP1</b> | Black, brown or white |                 |
| <b>LLP1</b> | Black, brown or white |                 |
| <b>LLP3</b> | Black, brown or white | With key holder |
| <b>LLP4</b> | Black, brown or white | With key holder |

## PRODUCT 50 INTUMESCENT LINER FOR MAIL APERTURES

- Intumescent liner
- The liner can be cut to size with a sharp knife to fit the opening
- Sizes to suit other openings can be made to order
- Comprising two L-shaped sections fitted with self-adhesive backing for ease of fixing

### USE

For mail apertures in fire doors, where existing letter flaps are to be used. Aperture sizes up to the limit for each type (LBL1 and LBL2) can be accommodated by cutting the liner with a sharp knife as required. A bare wood aperture must be sealed with paint or wood sealer before fixing the liner. Suitable for fitting to doors from 38mm to 70mm thick.



### ORDERING REFERENCES

|                             |          |
|-----------------------------|----------|
| <b>LBL1</b>                 | 85x340mm |
| <b>LBL2</b>                 | 65x290mm |
| Special sizes made to order |          |

### FIRE TEST PERFORMANCE

|                      |  |        |
|----------------------|--|--------|
| BS476 Part 22 (1987) | Built into a composite door, maintaining the integrity of the door | 61 min |
| EN1634-1 (2000)      | European Standard  | 68 min |



*One of the most economical and effective anti-arson products available*

Burning paper and liquids put through mail apertures in doors and walls can have devastating consequences, especially if premises are occupied. Nocturnal arson attacks on homes can be particularly worrying for domestic residents. The Envirograf® rigid firebox or flexible firebag protects mail slots, so homes and business can have the confidence that their premises are guarded against damaging and disruptive arson attacks. These products are safe to use because they do not contain liquids or gases. The intumescent lining puts out the flames.

*Even extinguishes petrol thrown through the letter box*

USE

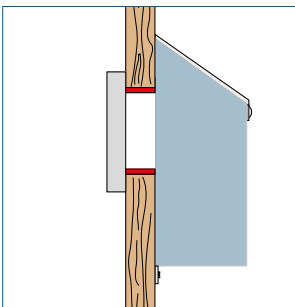

The firebox or firebag fits onto the back of the door or wall. Fire is extinguished by the intumescent material, which can be easily renewed.

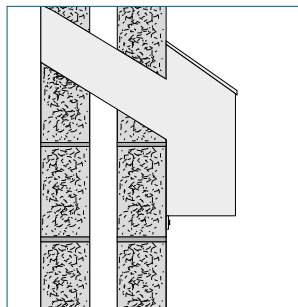

The firebox wall fitting, showing optional rigid spout for metal boxes.

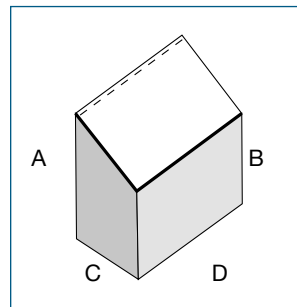

Rigid metal fireboxes are supplied with a hinged lid and flush lock as standard, but a hinged front door is available as an optional extra.



Use the flexible firebag in situations where doors open tightly onto walls, allowing full door opening.

ORDERING REFERENCES

METAL FIRE BOX

| Ref | A     | B     | C     | D     | Aperture     |
|-----|-------|-------|-------|-------|--------------|
| FB1 | 360mm | 300mm | 170mm | 375mm | 70mm x 275mm |
| FB2 | 360mm | 300mm | 90mm  | 375mm | 70mm x 275mm |
| FB3 | 360mm | 300mm | 200mm | 400mm | 70mm x 275mm |
| FB4 | 675mm | 600mm | 300mm | 600mm | 70mm x 275mm |

State if a front access door is required in the metal box (extra cost item). The standard metal box (FB) is fitted with a flush lock as standard, but can be supplied with a recessed lock at extra cost. Other sizes made to order.

FLEXIBLE FIRE BAG

| Ref    | A     | B     | C     | D     | Aperture     |
|--------|-------|-------|-------|-------|--------------|
| FLEX1  | 335mm | 335mm | 130mm | 420mm | 70mm x 315mm |
| FLEX2  | 335mm | 335mm | 130mm | 420mm | 55mm x 330mm |
| FLEX3  | 260mm | 260mm | 95mm  | 400mm | 55mm x 290mm |
| FLEX4V | 560mm | 560mm | 130mm | 360mm | 70mm x 315mm |
| FLEX5V | 530mm | 530mm | 100mm | 350mm | 55mm x 290mm |

FLEX2, FLEX3, FLEX4V, FLEX5V are for use in UPVC moulded doors

FLEX4V, FLEX5V are used in a vertical orientation.

Flexible bags (FLEX) are fitted with metal turn-buttons and pressure-fastening strips.

 FIRE TEST PERFORMANCE

BS476 Part 22 (1987)

Test for external fire doors

## PRODUCT 68

## REBATED INTUMESCENT FIRE SEALS

- Self-adhesive backing
- Up to one hour of fire protection
- Supplied in 1050mm and 2020mm lengths
- Available in black, brown, red, white and real wood veneer facings

### USE

For use in frames, edges of fire doors and behind door frames. Once fitted, the facing of the seal can be painted. Note: All fire doors must now be fitted with intumescent seals.



### SINGLE ACTION DOORS

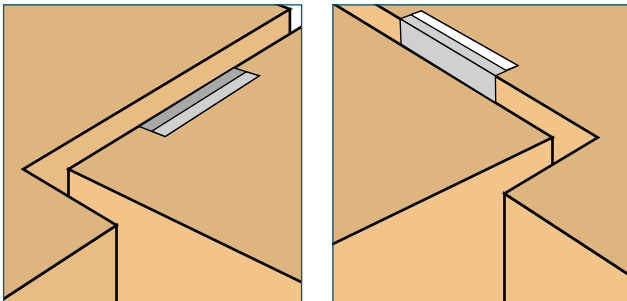

Fitted in door

Fitted in frame

### DOUBLE ACTION DOORS

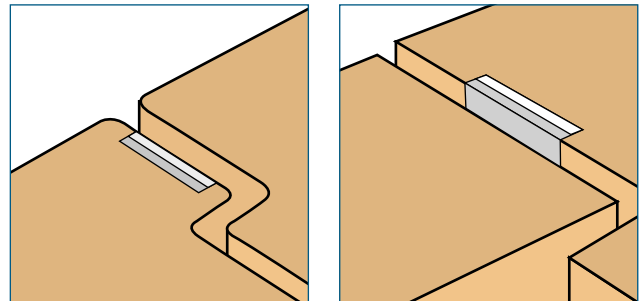

Rebated meeting stiles

Unrebated meeting stiles

### FITTING REQUIREMENTS FOR 68 & 69

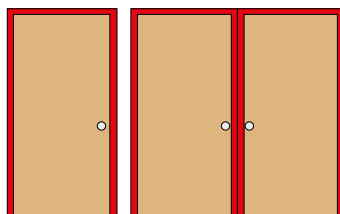

Single      Double

Shows position of door seals fitted to door or frame

### FIRE TEST PERFORMANCE

|                      |                |        |
|----------------------|----------------|--------|
| BS476 Part 22 (1987) | hardwood doors | 60 min |
|                      | softwood doors | 33 min |

### RELATED PRODUCTS 69, 76, AND 100

### ORDERING REFERENCES

| Ref   | Size (mm) | Protection |
|-------|-----------|------------|
| ES102 | 10 x 2    | 30 min     |
| ES103 | 10 x 3    | 30 min     |
| ES104 | 10 x 4    | 30 min     |
| ES154 | 15 x 4    | 60 min     |
| ES202 | 20 x 2    | 60 min     |
| ES203 | 20 x 3    | 60 min     |
| ES204 | 20 x 4    | 60 min     |
| ES252 | 25 x 2    | 60 min     |
| ES253 | 25 x 3    | 60 min     |
| ES254 | 25 x 4    | 60 min     |

| Ref   | Size (mm) | Protection |
|-------|-----------|------------|
| ES283 | 28 x 3    | 60 min     |
| ES302 | 30 x 2    | 60 min     |
| ES303 | 30 x 3    | 60 min     |
| ES304 | 30 x 4    | 60 min     |
| ES383 | 38 x 3    | 60 min     |
| ES384 | 38 x 4    | 60 min     |
| ES403 | 40 x 3    | 60 min     |
| ES483 | 48 x 3    | 60 min     |
| ES484 | 48 x 4    | 60 min     |
| ES503 | 50 x 3    | 60 min     |

See price list for full range of sizes. Available in 1050mm or 2020mm lengths  
Finishes: black, brown, red, white or real wood veneer

**PRODUCT 69 SURFACE-MOUNTED INTUMESCENT FIRE & FIRE/SMOKE SEAL**



- A surface-mounted intumescent fire seal or fire and smoke seal
- Available in black, brown, red, white and real wood veneer finishes
- Supplied with intumescent paper for use around lock
- Two labels printed “Fire Door – Keep Shut”
- No routing is necessary

*Installed for over 20 years in many heritage buildings*

**USE**

This product can be fitted to door frames in minutes. A 3½mm or greater gap down the closing stile and across the door head is all that is required. Seals fit directly over hinges with no hinge bind. No special gap is necessary on the hinge side. Once fitted, the face of the seal can be painted, although the brush smoke seal must NOT be painted. If the brush is painted in error, it is easy to replace. Pins are supplied for pushing into the brush seal, although the brush has a self-adhesive strip at the back. Please ensure that the closing corner edge of the door is slightly rounded for use with this seal.

**FIRE TEST PERFORMANCE**

|                      |                                  |        |
|----------------------|----------------------------------|--------|
| S476 Part 22 (1987)  | 11mm gap at the head of the door | 66 min |
| BS476 Part 23 (1987) | Intumescent strips tested        |        |

**SINGLE ACTION DOORS**

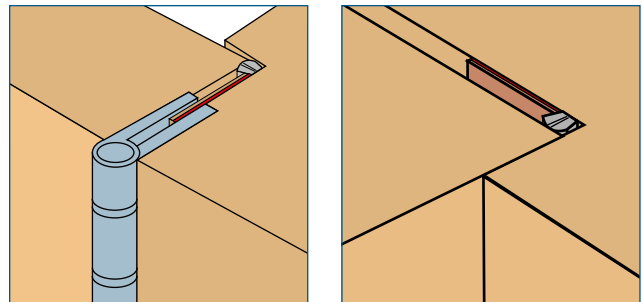

Hinge side of the doors

Closing edge and head

**DOUBLE ACTION DOORS**

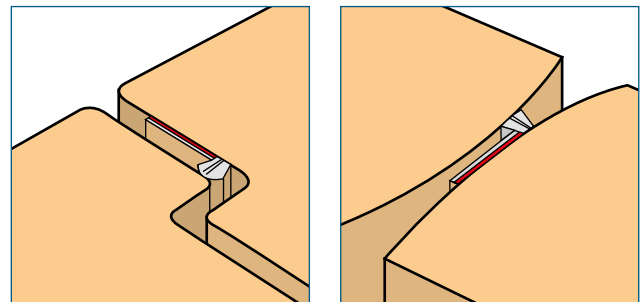

Rebated meeting stiles

Curved meeting stiles

**ORDERING REFERENCES**

|               |                             |
|---------------|-----------------------------|
| <b>ES</b>     | <b>Fire and Smoke Seals</b> |
| <b>ES/SDS</b> | Single door set             |
| <b>ES/DDS</b> | Double door set             |

|   |   |
|---|---|
| <b>Single 1050mm Fire and Smoke Seal Strips</b> |   |
| <b>ES/25/HS</b>                                 | For head and closing stile<br>2.5mm thick x 25mm wide x 5mm brush |
| <b>ES/30/PS</b>                                 | For hinge side 1mm thick x 30mm wide x 3mm brush                  |

**FITTING REQUIREMENTS SEE PRODUCT 68**

|               |                        |
|---------------|------------------------|
| <b>NS</b>     | <b>Fire Seals Only</b> |
| <b>NS/SDS</b> | Single Door            |
| <b>NS/DDS</b> | Double door            |

|  |   |
|--|---|
| <b>Single 1050mm Fire Seal Strips (no smoke seal)</b>                          |   |
| <b>NS/25/HS</b>  | For head and closing stile<br>2.5mm thick x 25mm wide |
| <b>NS/30/PS</b>  | For hinge side 1mm thick x 30mm wide                  |
| Longer brush sizes can be supplied to order<br>Please state size when ordering |   |

State whether rebated or open stiles on double doors and the finish required.

Packs are supplied with intumescent paper for use in lock areas and labels printed “Fire Door – Keep Shut” - see price list for full range.

If the gap at the closing stile and across the head of the door is less than 3mm, request packs containing only 1mm thick ES/30/PS seals.

**NEW ITEM: V-shaped rubber surface seal**

|                 |                 |
|-----------------|-----------------|
| <b>ES/SDS/P</b> | Single door set |
| <b>ES/DDS/P</b> | Double doorset  |



## PRODUCT 70

## REPLACEMENT HARDWOOD DOOR EDGING



- Supplied in 2100mm lengths.
- For gaps of 3mm, 5mm, and 7mm
- Brush seals available for other gap sizes.
- Supplied with adhesive and full fixing instructions
- To fit doors with a thickness between 40mm and 56mm
- Brush smoke seals available in black, grey and white
- Complete door edging with concealed intumescent and smoke seal
- Edging wood is supplied in standard sapele finish (other finishes available)
- Other lengths can be supplied

### ES46E: FOR DOORS 40-46MM THICK

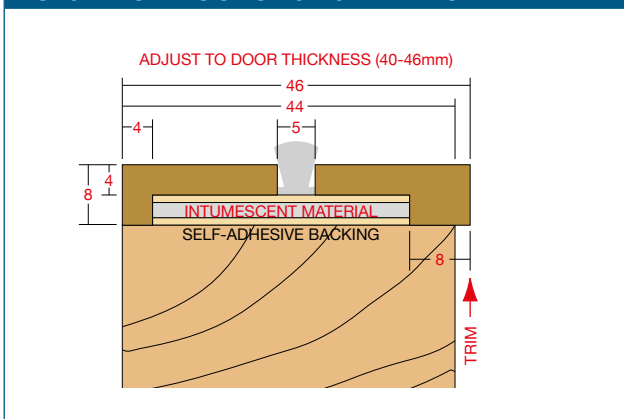

### ES56E: FOR DOORS 50-56MM THICK

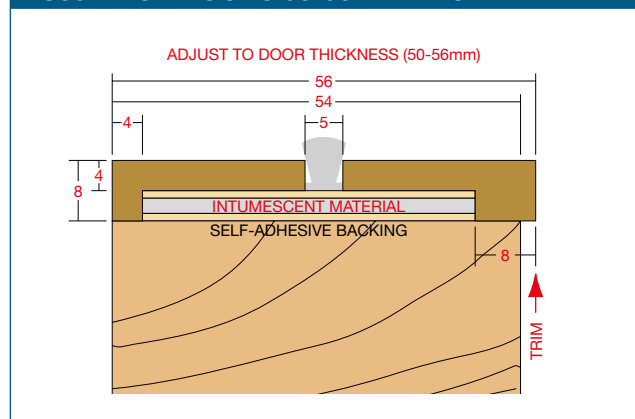

### ORDERING REFERENCES

**ES46E** 46mm wide  
For door thicknesses 40-46mm (trim excess)

**ES56E** 56mm wide  
For door thicknesses 50-56mm (trim excess)

State colour and size of brush smoke seal required

### USE

Where door edges are regularly damaged and need maintenance, for example in hotels, hospitals and computer rooms, Envirograf® easy-to-fit replacement door edging is ideal, as it saves the cost of replacing the entire door. See also Envirograf® Product 108 (door edge protective trim) on p24.

### FITTING INSTRUCTIONS

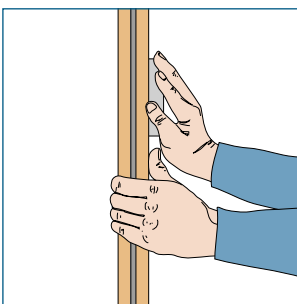

Remove the existing door edge with a sharp knife, chisel or saw, then rub down the edge with glass paper. If necessary (depending on the gap between door and frame) some planing may be required to allow for the replacement door edge.

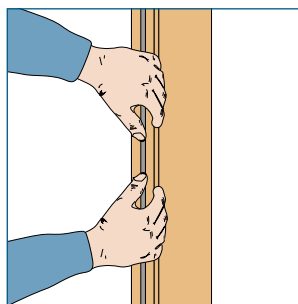

Replacement door edge fits flush one side (other side is wider to allow for planing down – see diagrams). Apply supplied glue to prepared door edge.

Remove backing paper from self-adhesive strip on back of the replacement door edge. Press firmly into position.

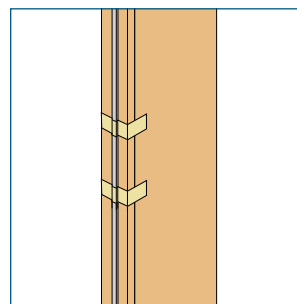

Hold the door edge firmly in place with masking tape while the glue sets (about 10-20 minutes).

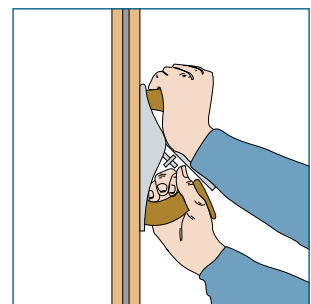

Finally, remove the masking tape and smooth down the projecting edge with a suitable plane and/or glass paper.



## PRODUCT 71

## HINGE LOCK AND DOOR CLOSER PROTECTION

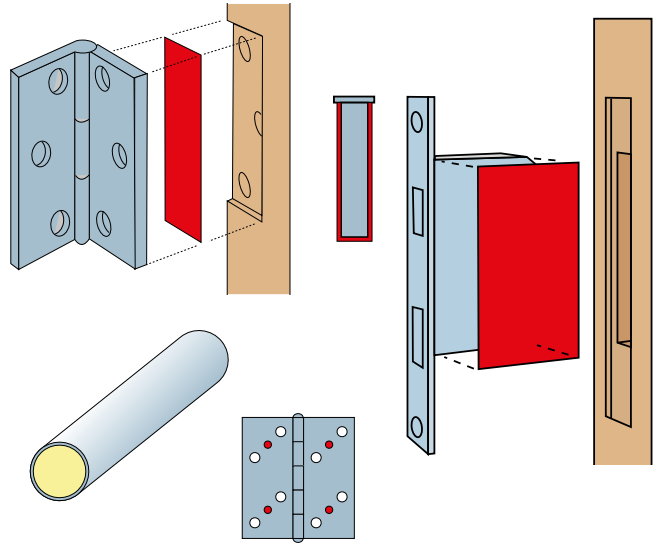
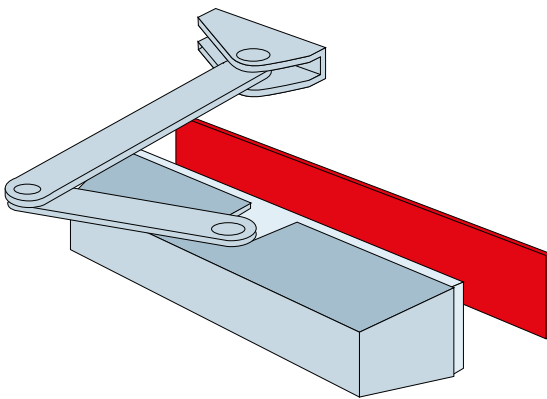

- Required to comply with BS476 Part 22 (1987) and Document B of UK Building Regulations
- Flexible intumescent protection sheet
- 1mm thick
- Unaffected by moisture
- Supplied in standard sizes
- Quick and easy fitting
- Some with self-adhesive backing

### USE

The intumescent sheets are used behind hinges and steel door closers. Simply wrap the material around the hidden parts of the door ironmongery on a fire-rated door to ensure full protection.

When installed, the sheet compresses without compromising its protective qualities unlike mastic which is ineffective for hinge, lock and door closure protection. The intumescent paper cools the lock, hinges and screws and protects them from overheating in the event of a fire. Under UK Building Regulations and BS476 Part 22 (1987), all door furniture must be protected by intumescent material.

The product range includes a plastic tubular plug containing flexible intumescent material for fixing screws into holes in solid surfaces. Plugs can be used in door hinges to protect the hinges by cooling them down in a fire. The intumescent material expands around the hinges, cooling the metal. Available in 38mm lengths with a choice of two diameters: 6mm or 8mm.



### FIRE TEST PERFORMANCE

|                      |        |
|----------------------|--------|
| BS476 Part 22 (1987) | 91 min |
| EN1634-1 (2000)      | 68 min |

### ORDERING REFERENCES

| Ref   | Adhesive                            | Size        | Notes              |
|-------|-------------------------------------|-------------|--------------------|
| HP 32 | <input checked="" type="checkbox"/> | 32 x 300mm  |                    |
| HP 36 | <input checked="" type="checkbox"/> | 36 x 300mm  |                    |
| HP 48 | <input checked="" type="checkbox"/> | 48 x 300mm  | Behind hinge areas |
| HP300 | <input checked="" type="checkbox"/> | 300 x 300mm | Around lock areas  |
| LPH   | <input checked="" type="checkbox"/> | 150 x 225mm | Lock areas/closers |

ES / PLUG      Grey

Request adhesive backing if required for HP300 and LPH

## NEW CE-APPROVED SELF-CLOSING HINGE (SET OF 3)



- No need to install door closure devices
- Especially useful in student quarters HMO's and other areas susceptible to vandalism
- Hinges can be adjusted, e.g. to latch, the centre hinge can have more tension
- Antique brass, brown, chrome, stainless steel, white
- This set of 3 hinges acts as a complete door closer
- Tightened top hinge to allow for buckled door stops
- Ideal for use in conservation areas

### ORDERING REFERENCES

SCH      Set of three hinges for one fire door



### FIRE TEST PERFORMANCE

|                      |           |
|----------------------|-----------|
| BS476 Part 22 (1987) | 30/60 min |
| EN1634-1 (2000)      | 68 min    |

Tested by FIRA for age, wear and weight for 80,000 cycles at 90° and 90,000 cycles at 400mm opening and closing.

## PRODUCT 76

## REBATED INTUMESCENT FIRE AND SMOKE SEALS WITH ALUMINIUM HOLDER

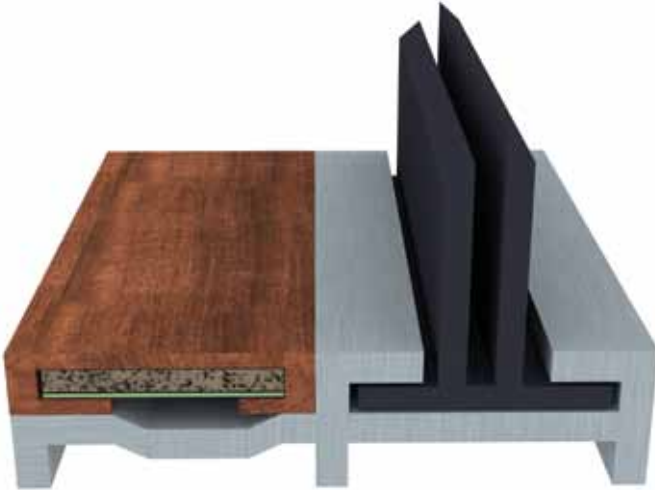

### SUMMARY

- An aluminium holder with intumescent fire and smoke seal, fitted into rebated fire doors or frames
- Maintains integrity and restricts the passage of fire and smoke in the event of a fire

### ES/SM30

- 30 minutes fire-rated
- 7mm deep x 9mm wide x 2200mm long
- Aluminium holder
- Choice of brush or straight rubber seal
- Brush smoke seals are available in black, brown, grey or white and 5mm, 7mm or 10mm high
- Straight rubber seal is 4mm or 7mm high

### ES/SM60

- 60 minutes fire-rated
- 6mm deep x 20mm wide x 2200mm long
- Aluminium holder
- Intumescent facing
- Aluminium holder that houses various colour/veneer finish fire seal options
- Brush and rubber seal sizes as above

### ES/SM60/P

- A plastic holder with intumescent material
- 8mm deep x 20mm wide x 2200mm long
- In aluminium, black, brown, red and white
- For fitting into the rebate

### ES/SM60

- Providing increased protection and sealing efficiency

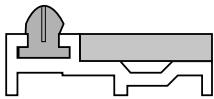

**ES/SM60/B**  
5/7/10mm Seal

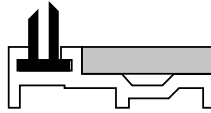

**ES/SM60/S**  
5/7/10mm Seal



**ES/SM30/S**  
5/7/9mm Seal  
Brush seal available



**ES/SM60/P**  
Plastic strip only

### FITTING INSTRUCTIONS

**ES/SM60:** Fit the aluminium profile into the rebate and fix with the nails supplied. Peel off the backing strip from the intumescent finishing piece and adhere it to the aluminium holder, thus hiding the heads of the fixing nails.

### ES/SM60/P & ES/SM30

Peel off the backing strip from the profile and adhere into the rebate

### IMPORTANT:

The brush seal length must be between 1-1.5mm longer than the door gap between frame or adjacent double door.

### SINGLE ACTION DOORS

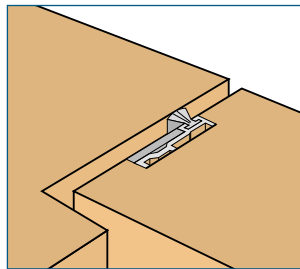

Seal fitted in door

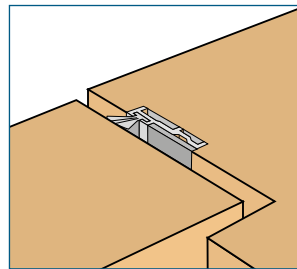

Seal fitted in frame

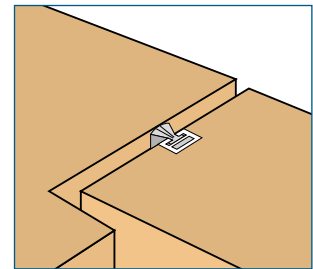

Position for ES/SM30

### DOUBLE ACTION DOORS

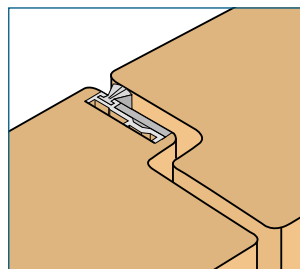

Rebated meeting stiles  
Brush or rubber seal  
ES/SM30 or ES/SM60

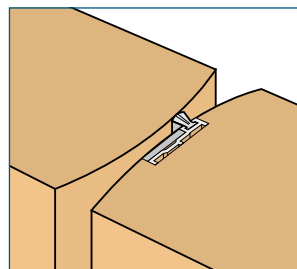

Unrebated meeting stiles

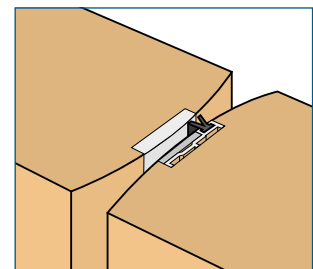

Position for ES/SM60  
Use ES/SM60 brush or rubber seal

|  <b>FIRE TEST PERFORMANCE</b> |   |              |
|--|---|--------------|
| BS476 Part 22 (1987)   | An aluminium holder that houses Envirograf® Product 100 | 30 or 60 min |
| BS476 Part 23 (1987)   |   | 69 min       |

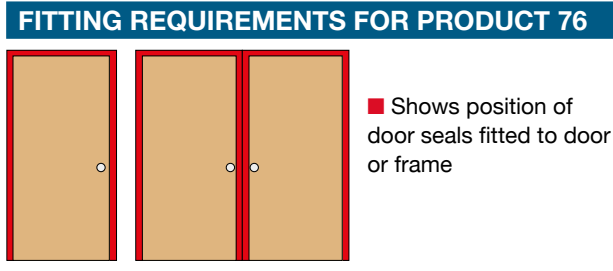

| ORDERING REFERENCES |           |                  |                    |
|---------------------|-----------|------------------|--------------------|
| Ref                 | Holder    | Dimensions       | Seal               |
| ES/SM30/B           | Aluminium | 7 x 9 x 2200 mm  | Brush              |
| ES/SM30/S           | Aluminium | 7 x 9 x 2200 mm  | Straight Rubber    |
| ES/SM60/B           | Aluminium | 6 x 20 x 2200 mm | Brush              |
| ES/SM60/S           | Aluminium | 6 x 20 x 2200 mm | Straight Rubber    |
| ES/SM60/P           | Plastic   | 8 x 20 x 2200 mm | ES/SM60 seals ONLY |

State holder colour/finish and brush colour if necessary

For single and double-action doors, the straight rubber seal is preferred

**PRODUCT 78 ENVIROSTRIP/F**



**USE**

Fitted into the closing edge door frame corner. Self-adhesive backing for ease of fixing, with maximum adhesion achieved after 72 hours in situ. For extra security, additional panel pin fixing may be employed if desired. This low-cost seal is ideal for public housing projects by councils and housing associations, to be fitted on all internal and external doors in apartments and houses, in positions where it will not be damaged.

| ORDERING REFERENCES |                      |
|---------------------|----------------------|
| ENVIROSTRIP         | (fire-rated version) |

|  <b>FIRE TEST PERFORMANCE</b> |        |
|--|--------|
| BS476 Part 22 (1987)   | 30 min |
| Also has acoustic properties for airborne sound.   |        |

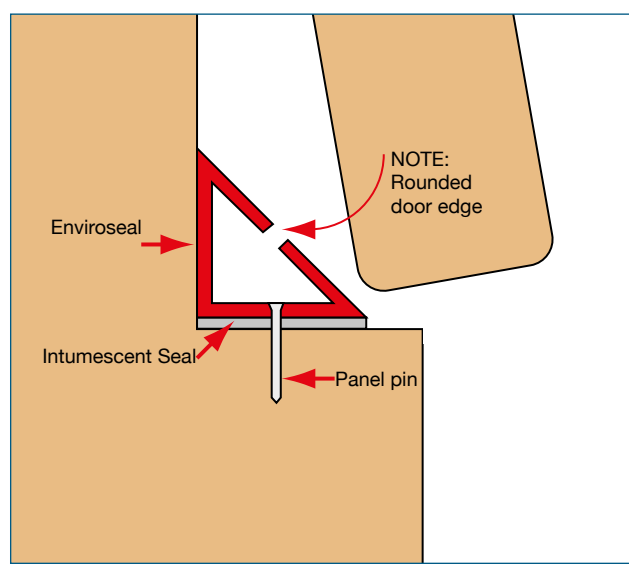

## PRODUCT 77

## INTUMESCENT GLAZING STRIPS

- 2mm thick compressible intumescent strip
- In black, brown, grey, red, and white
- Self-adhesive tape backing
- Supplied in 10m long rolls

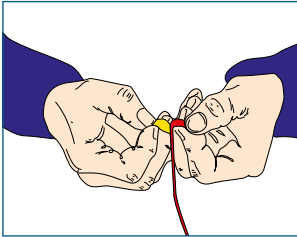

Grip the self-adhesive backing strip and separate the protective paper from the adhesive

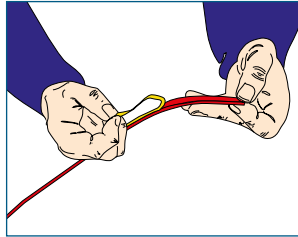

Pull along for a few centimetres to expose the adhesive surface ready for adhering onto the glazing beads

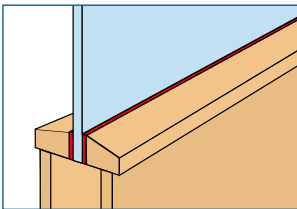

Attach the intumescent strip to the face of the bead as shown left, peeling away additional backing paper as necessary.

### USE

Designed for use in wooden doors and partitioning. The strips are fitted to beads each side of the fire-rated glazing. Although the seal is 2mm thick, it will compress to 0.5mm and this will not affect its performance. For 30 minutes glazing: 10mm or 15mm beads must be fixed with 36mm panel pins at 200mm centres. For 60 minutes glazing: 20-25mm beads use 60mm No.8 CS steel screws at 200mm centres.

### ORDERING REFERENCES

| Ref    | Width | Protection |
|--------|-------|------------|
| G 8/10 | 8mm   | 30 min     |
| G10/10 | 10mm  | 30 min     |
| G15/10 | 15mm  | 30 min     |
| G20/10 | 20mm  | 60 min     |
| G23/10 | 23mm  | 60 min     |

State the colour finish required



### FIRE TEST PERFORMANCE

|                      |  |              |
|----------------------|--|--------------|
| BS476 Part 22 (1987) | 10mm thick hardwood<br>15mm thick softwood | 45 min       |
|                      | 20mm wide hardwood                         | up to 65 min |

## PRODUCT 79

## GLAZING BEAD SYSTEM FOR FIRE DOORS AND SCREENS

- A complete glazing system consisting of 2100mm long wooden beads
- Bolection moulding if required
- Standard finishes include sapele and pine
- Treated with Envirograf® clear intumescent coating
- Others available to order

### USE

Ideal for doors and partition screens. The beads can be painted or varnished. Supplied with appropriately-sized fixing pins or screws for fixing at 200mm intervals along the length. Flat section beading is used for partition sections, bolection moulding is typically used in fire door glazing sections.

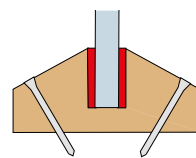

30 minute protection  
Fix using panel pins

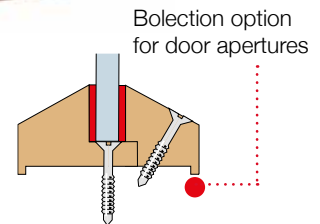

30 minute protection  
Fix using screws

### ORDERING REFERENCES

| Straight  | Bead Size | To Suit    | Wood | Protection |
|-----------|-----------|------------|------|------------|
| 30/G10    | 10mm      | 44mm doors | hard | 30 min     |
| 30/G15    | 15mm      | 44mm doors | soft | 30 min     |
| 60/G25/44 | 25mm      | 44mm doors | hard | 60 min     |
| 60/G25/54 | 25mm      | 54mm doors | hard | 60 min     |



### FIRE TEST PERFORMANCE

|                      |  |             |
|----------------------|--|-------------|
| BS476 Part 22 (1987) | 10mm thick hardwood<br>15mm thick softwood | 45 min      |
|                      | 25mm wide hardwood                         | over 68 min |

Add suffix /L if bolection moulding (lip) is required

## PRODUCT 97 DOOR STOP WITH INTUMESCENT FIRE SEAL & BRUSH OR NEOPRENE SMOKE SEAL

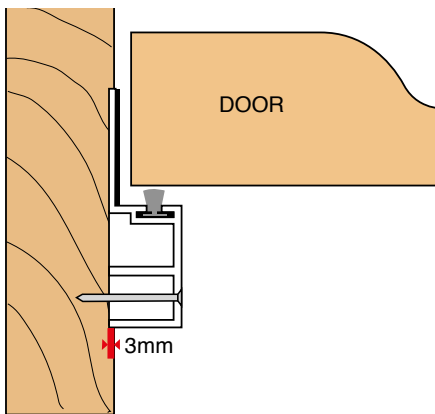

- Brown, grey, or white plastic
- Includes intumescent fire seal and brush smoke seal
- Can be used in conjunction with the threshold seals - Products 106 or 107 - please enquire
- Designed to upgrade normal hollow-core doors and to replace existing wooden door stops

### USE

Can be used for new installations, as a combined surface-mounted doorstop, brush smoke seal and intumescent fire seal. Alternatively, the intumescent section can be routed into the door frame lining, with a rebate of 3mm deep x 50mm wide.

The standard smoke seal supplied is a 5mm brush. Rubber seals may also be used. All of these seals offer draught and smoke protection.

This product should be fitted to the most vulnerable doors, including non-fire-rated doors, such as dining room and kitchen.

The smoke seal helps to ensure a fire escape route free from smoke, and the intumescent seals the gap between the door and frame to inhibit the spread of fire. The seal is screwed to the exterior of the door face and offers weather protection to the flat threshold seal.

### APPLICATION

Remove the backing from the self-adhesive strip on the back edge of the seal, then position and finish with the panel pins supplied.

#### IMPORTANT:

The door seal length must be between 1-1.5mm longer than the door gap between the frame and adjacent door.

### ORDERING REFERENCES

| Ref   | Set          | Dimensions                       |
|-------|--------------|----------------------------------|
| DSU/S | Single door  | 2 x 2100mm and 1 x 1050mm pieces |
| DSU/D | Double doors | 3 x 2100mm and 1 ES/25/HS pieces |

## PRODUCT 102 INTUMESCENT MATERIAL TO FIT UNDER DOOR LIPPING

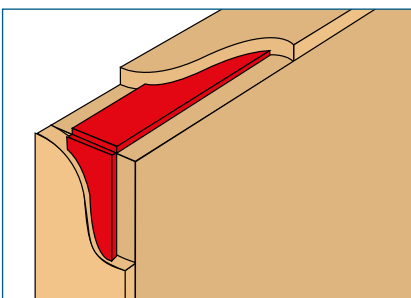

- Self-adhesive 2mm thick intumescent material
- Fits under hardwood door lipping as a fire protection seal (ES/UL)
- The material is protected from damage by the hardwood door lipping
- Expands in a fire to seal the gaps between door and frame
- Also supplied with hardwood door edging (ES/DE/UL)
- To suit door edges 42-44mm and 52-54mm

### ORDERING REFERENCES

| Ref         | Door Thickness | Fire Protection |
|-------------|----------------|-----------------|
| ES/UL/25    | 25 mm          | 30 min          |
| ES/UL/30    | 44 mm          | 30 or 60 min    |
| ES/UL/34    | 50 mm          | 60 min          |
| ES/DE/UL/30 | 42-44 mm       | 30 or 60 min    |
| ES/DE/UL/34 | 52-54 mm       | 60 min          |

### USE

The strip is fitted to the underside of the hardwood lip on the edges of the door.



### FIRE TEST PERFORMANCE

BS476 Part 22 (1987)

60 min

# Our new unique **'CLIP-IN'** door seal

## Simple, rapid **installation**

The new push-fit seal simply clips in and out of the groove making adjustments at the door fitting stage easy and fast.

### Rout grove 5mm deeper

By simply routing a groove 5mm deeper than required for the seal itself, the additional grooving if door edges need further planing is eliminated. When the door set correctly closes and is ready for use, the carpenter just clips the seal into the groove.

## Ease of use during **re-decoration**

The seal can be easily removed, from the top or bottom of the door using a screw driver to release it, so that decoration can occur without damaging the seal.

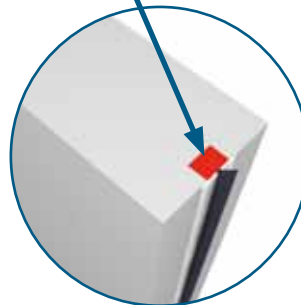
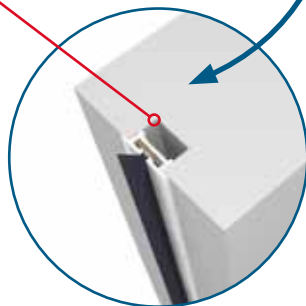
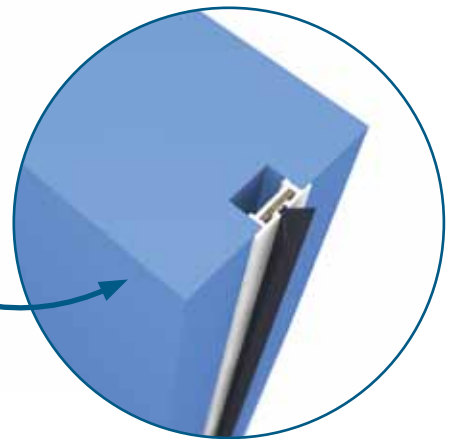

In a fire this is a powerful fire seal. The intumescent is contained on the back edge facing the deeper groove. In the case of fire, the intumescent fills the groove and then powerfully pushes against the frame edge holding the door firmly in place, protecting the escape route from both fire and smoke.



Brush options are available

### NEW – THE PUSH-FIT DOOR SEAL

Installing intumescent strip seals on fire doors can be a real problem! Fitting a door set in any situation is a time consuming job since ensuring a careful fit with hinges and locks fitted correctly requires care, skill and time. Fitting the intumescent seal is an added job. It requires a groove to be routed. The seal is then fixed with pins. Often, when the doors require adjustment to close correctly, the seal needs to be removed for the door edges to be planed down. The groove for the seal then requires re-routing, using up further valuable time. Envirograf® have now designed a unique fire door strip seal that overcomes all of these frustrating problems. The new push-fit seal simply clips in and out of the groove making adjustments at the door fitting stage easy and fast.

## ORDERING REFERENCES: NEW PUSH-FIT STYLE 2100MM LENGTHS

| Ref       | Fire Seal   | Smoke Seal      | Depth x width | Fire Rated   |
|-----------|-------------|-----------------|---------------|--------------|
| CIS14/30  | Intumescent | None            | 5mm x 10mm    | Up to 40 min |
| CIS14/B30 | Intumescent | Brush Seal      | 5mm x 10mm    | Up to 40 min |
| CIS14/S30 | Intumescent | Straight Rubber | 5mm x 10mm    | Up to 40 min |
| CIS15/60  | Intumescent | None            | 5mm x 15mm    | Up to 68 min |
| CIS15/B60 | Intumescent | Brush Seal      | 5mm x 15mm    | Up to 68 min |
| CIS15/S60 | Intumescent | Straight Rubber | 5mm x 15mm    | Up to 68 min |

Brush smoke seals, where fitted, are 5mm standard  
In black, brown, grey, or white

Standard range holders are brown or white  
Other colours may be available – please ask

NB: Approximately 1-1½mm of seal is contained inside the holder. Brush with fin is ½mm higher than brush with no fin.

## REBATED INTUMESCENT FIRE SEALS - NON PUSH FIT

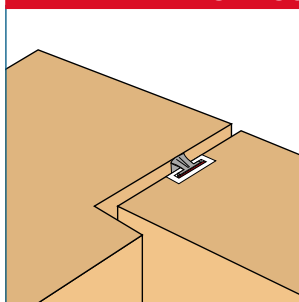

Single action doors

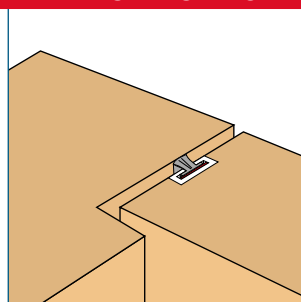

Double action doors  
with rebated meeting stiles

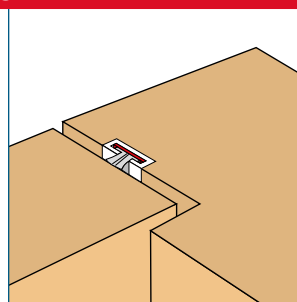

Single action doors (frame)

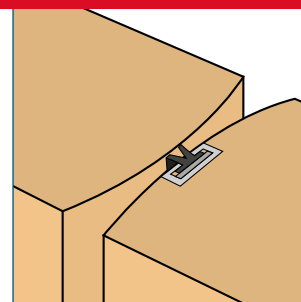

Double action doors  
with unrebated meeting stiles

## USE

Used for fitting to doors, door frames, and windows. Once fitted, the plastic facing of the seals can be painted, although the brush or rubber smoke seal must NOT be painted.



## FIRE TEST PERFORMANCE

|                                   |               |
|-----------------------------------|---------------|
| BS476 Part 23 (1987)              | 69 min        |
| BS476 Part 20 and 22 (1987)       | 40 and 60 min |
| European Standard EN1634-1 (2000) | 68 min        |

## ORDERING REFERENCES: ORIGINAL STYLE 1050MM & 2100MM LENGTHS

| Ref      | Fire Seal   | Smoke Seal      | Depth x width | Fire Rated   |
|----------|-------------|-----------------|---------------|--------------|
| IS/12    | Intumescent | None            | 4mm x 12mm    | Up to 30 min |
| IS/12/S  | Intumescent | Brush           | 4mm x 12mm    | Up to 30 min |
| IS/13    | Intumescent | None            | 3mm x 10mm    | Up to 30 min |
| IS/13/S  | Intumescent | Brush           | 3mm x 10mm    | Up to 30 min |
| IS/14    | Intumescent | None            | 4mm x 10mm    | Up to 30 min |
| IS/14/S  | Intumescent | Brush           | 4mm x 10mm    | Up to 30 min |
| IS/14/AS | Intumescent | Angled Rubber   | 4mm x 10mm    | Up to 30 min |
| IS/14/SS | Intumescent | Straight Rubber | 4mm x 10mm    | Up to 30 min |
| IS/15    | Intumescent | None            | 3mm x 15mm    | Up to 60 min |
| IS/15/S  | Intumescent | Brush           | 3mm x 15mm    | Up to 60 min |
| IS/154/S | Intumescent | Brush           | 4mm x 15mm    | Up to 60 min |
| IS/24    | Intumescent | None            | 4mm x 20mm    | Up to 60 min |
| IS/24/S  | Intumescent | Brush           | 4mm x 20mm    | Up to 60 min |
| IS/24/AS | Intumescent | Angled Rubber   | 4mm x 20mm    | Up to 60 min |
| IS/24/SS | Intumescent | Straight Rubber | 4mm x 20mm    | Up to 60 min |



**Manufactured from high tensile UPVC - The Envirograf® door edge protection trim is the most robust, durable and long lasting door trims now available!**

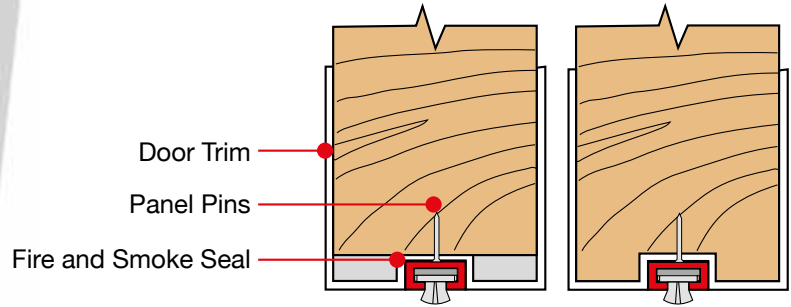

● Rebated fitting option

- For door edges at high risk of damage e.g. airports, hospitals, industrial buildings etc
- Brown or white durable plastic trim
- Hard-wearing physical protection to door edges
- Additional fire and smoke protection when combined with Envirograf® Product 100
- Extends the life of the door avoiding an expensive replacement
- The product is supplied in two sizes to suit door thicknesses 42-46mm and 52-56mm
- Fits rebated on new doors or surface-mounted on old or damaged doors

**USE**





This product can be rebated or surface-mounted on the door edge. The door edge protective trim simply slips over the door edge in one piece (or in two pieces for thicker doors: separate into two pieces by rocking along the central line until the parts separate). Peel off the backing paper of the self-adhesive strip on the inside edges of the trim. Slip the door trim piece(s) over the door edge and fix with panel pins through the grooved section

(not through the smoke seal). If fitting an Envirograf® Product 100 fire and smoke seal, remove the backing paper from the self-adhesive strip on the back of the seal holder, then press it into the rebate in the door edge protective trim.

**ORDERING REFERENCES**

|  |  |
|--|--|
| <b>DET44/N</b>   | Rebating into new doors 42-46mm thick                    |
| <b>DET54/N</b>   | Rebating into new doors 52-56mm thick                    |
| <b>DET44</b>   | Surface-mounting onto old or damaged doors 42-46mm thick |
| <b>DET54</b>   | Surface-mounting onto old or damaged doors 52-56mm thick |
| State the colour of door edge protector moulding required      |  |
| State the colour of the seal holder and the seal type required |  |

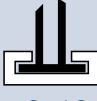
|   |   |   |
|---|---|---|
|  |  |  |
| Holder  | Seal B  | Seal S  |
| Seal Size   | 5/7/10mm  | 5/7/9mm   |

**IMPORTANT**

- 1-1.5mm of the brush/rubber seal is held within the holder
- Brush with fin is always 0.5mm higher than without
- Make allowances when specifying
- The fire/smoke seal holder sizes are 10 x 4mm or 20 x 4mm to fit into the door protector

**FIRE TEST PERFORMANCE**

|   |               |
|---|---------------|
| BS476 Part 23 (1987)  | 69 min        |
| Product 100 seal has also been tested to BS476 Parts 20 and 22 (1987) | 46 and 68 min |
| EN1634-1 (2000) European Standard                                     |               |



**PRODUCT 109 INTUMESCENT GLAZING CHANNELS**



- A rigid white plastic glazing channel with intumescent fire protection
- Available in heights of 10mm for 30 min fire protection and 15mm for 60 min fire protection

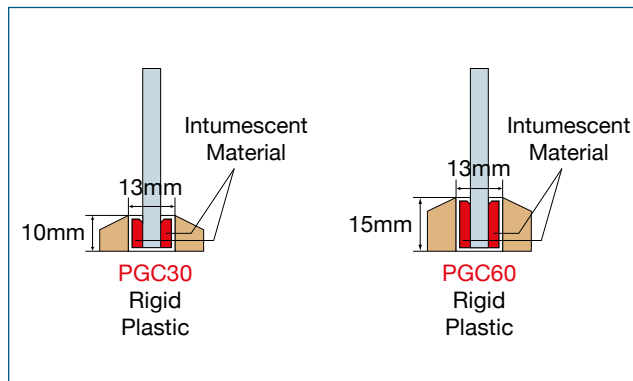

**USE**

Designed for areas where noise and vibration are common. The rubber channel absorbs sound and accommodates small movements more efficiently than standard glazing fixtures and it offers fire protection. Use with the intumescent for non-insulated glass such as 6 mm wired, ceramic or laminated glass, or on insulated glass.

**ORDERING REFERENCES**

| Ref   | Height | Protection |
|-------|--------|------------|
| PGC30 | 10mm   | 30 min     |
| PGC60 | 15mm   | 60 min     |

PGC = rigid glazing channel to fit 5-7mm thick glass  
 Hardwood/softwood beading can be supplied to house the channel

**FIRE TEST PERFORMANCE**

|                      |           |        |
|----------------------|-----------|--------|
| BS476 Part 22 (1987) | 10mm high | 40 min |
|                      | 22mm high | 66 min |

**PRODUCT 116 PROTECTOR FOR ETCHED OR STAINED GLASS**

- 2100mm long metal trim
- Standard finishes of brown or white
- Other colours available
- Complete with pre-fixed intumescent seal
- Applied to the framed area on the inside of the room with the matching screws supplied

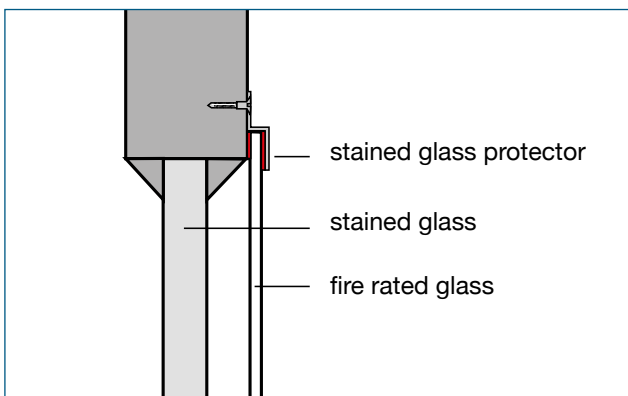

**USE**

The protector holds clear wired glass, laminated glass or ceramic fire protection glass behind decorative glazing, thereby giving 30 or 60 minutes of fire protection, leaving the decorative glass undisturbed.

Supplied in 2100mm lengths. Can also be supplied in curved sections (e.g. arches). When fitted, the protector is unobtrusive and would not normally be noticed.

**ORDERING REFERENCES**

|    |                                  |
|----|----------------------------------|
| GP | State the colour finish required |
|----|----------------------------------|

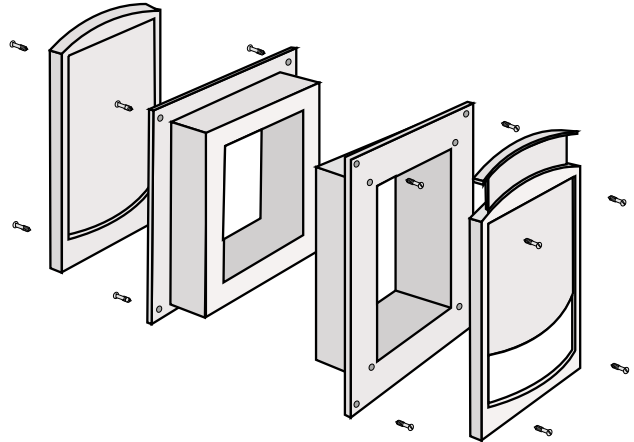

***You can let the cat out but  
don't let the fire out too!***

- Your standard door flap fits into our unit
- Standard finishes are brown, grey, and white
- Can be made to fit a brick wall of any thickness
- Designed for standard cat and dog (flaps - not supplied)
- Metal frame housing an Envirograf® Product 16 economy intumescent box
- The fitted intumescent and PVC-faced sponge is sufficiently smooth for a cat and dog to pass through
- Will not seal or expand until the fire has reached 120°C at the door - approximately 4 minutes into the fire

**USE**

For fire-rated doors in apartments and houses. In a fire, the intumescent material would expand, filling the hole and maintaining the integrity of the fire door. This Envirograf® product is simple to fit.

**FIRE TEST PERFORMANCE**

|                      |        |
|----------------------|--------|
| BS476 Part 22 (1987) | 68 min |
| prEN1366-3           |        |

**ORDERING REFERENCES**

| Ref  | To Suit Staywell Type  | Staywell Aperture | FP Aperture    |
|------|------------------------|-------------------|----------------|
| FP01 | Series 300 / 400 / 500 | 168mm x 175 mm    | 228mm x 235 mm |
| FP02 | Series 600 (Small)     | 245mm x 150 mm    | 305mm x 210 mm |
| FP03 | Series 600 (Medium)    | 348mm x 225 mm    | 408mm x 285 mm |
| FP04 | Series 600 (Large)     | 451mm x 277 mm    | 521mm x 347 mm |
| FP05 | Series 600 (X Large)   | 642mm x 366 mm    | 722mm x 446 mm |
| FP06 | Series 700 (Small)     | 180mm x 155 mm    | 240mm x 215 mm |
| FP07 | Series 700 (Medium)    | 265mm x 230 mm    | 325mm x 290 mm |
| FP08 | Series 700 (Large)     | 354mm x 306 mm    | 424mm x 376 mm |
| FP09 | Series 800             | 429mm x 291 mm    | 499mm x 361 mm |
| FP10 | Series 900             | 169mm x 169 mm    | 229mm x 229 mm |

To suit Staywell brand flaps. **Others can be made to suite other brands animal flap brands - please enquire.**

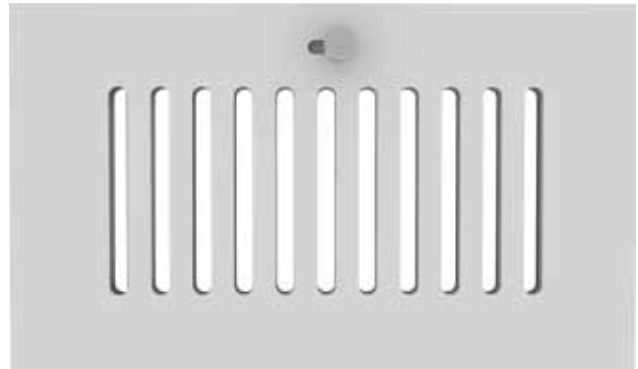
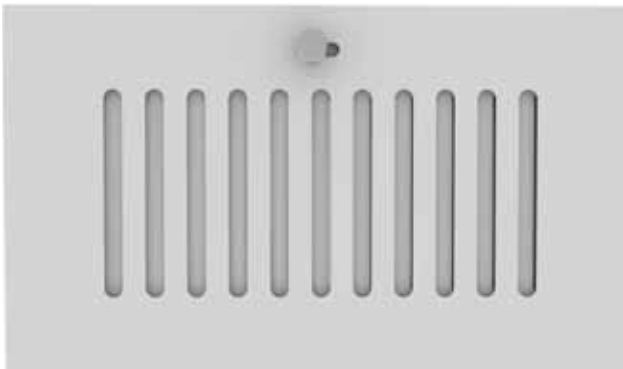

- Complete fire protection is offered whether the shutter is in the open or closed position
- Comprising of an internal sliding shutter plate with observation slots that can be moved sideways to align with observation slots on the external frame
- Supplied with 6mm thick unbreakable armoured glass giving extra security to domestic apartments and houses, detention rooms in police stations, healthcare institutes, prisons, etc

- Integral fire resistance
- For use in all security doors
- Available in 30 or 60 minute ratings
- A cutout size of only 229mm high and 368mm wide
- The door viewer is made from strong zintec sheet metal – 20 SWG or 0.92mm thick
- Finish: black, light bronze, brown, or white powder coating (other colours are available to order)
- Unique glass plate allows for discreet observation

**USE**

The viewer offers a greater panoramic view than is available through spy hole viewers, and it has the advantage of being able to be kept in the open position without compromising the integrity of the door in a fire. It is ideal for monitoring patients in hospitals, viewing occupants in conference rooms, meeting rooms, prisons, banks and other financial institutions, domestic residences, etc.



**FIRE TEST PERFORMANCE**

BS476 Part 22 (1987)

66 min

**ORDERING REFERENCES**

| Ref  | Contents         | Door Thickness | Fire Rating | Wood     |
|------|------------------|----------------|-------------|----------|
| DV30 | DV + Beading set | Up to 44mm     | 30min       | Softwood |
| DV60 | DV + Beading set | Up to 54mm     | 60min       | Hardwood |

Other viewers can be made to order to suit doors of other thicknesses

The product can be fitted with a locking device – state if required

**PRODUCT 133 AVG/F ACOUSTIC/FIREPROOF VENTILATION GRILLE**



- **AVG/F two part fireproof acoustic ventilation grille - one for each side of the opening**
- **Internal cavity of both sections is filled with micro-acoustic material**
- **Intumescent strips provide additional fire resistance properties risk side**
- **The grille is 25mm deep and in two sizes: 200 x 200mm and 400 x 200mm**
- **The ventilation area is about 0.4 x the slot length**
- **Various finishes are available**

**USE**

The grille can be used on partition walls and doors, to prevent fire passing from one room to another when acoustic protection is also needed. To accommodate the grille, the ventilation aperture must be at least 10mm larger than the height between the upper and lower opposing slot limits (the slots should be vertically opposite each other when fitted).

**ACOUSTIC PERFORMANCE**

|                 |   |
|-----------------|---|
| ISO140-3 (1995) | Maximum sound absorption at a minimal air-resistance (20 Pa) is achieved at an air speed no greater than 1.9m/s, calculated on the open passage of the grille, with measurement of the sound insulation |
|-----------------|---|

**FIRE TEST PERFORMANCE**

|                            |              |
|----------------------------|--------------|
| European Standards NEN6069 | up to 60 min |
| Plus sound absorption      |              |

**ORDERING REFERENCES**

| Ref   | State size                 |
|-------|----------------------------|
| AVG/F | 200 x 200mm or 400 x 200mm |

**PRODUCT 134 AVG ACOUSTIC VENTILATION GRILLE**

- **Contains micro-acoustic material to reduce the passage of sound from one room to another**
- **Available in a range of sizes and finishes (including anodised or natural aluminium)**
- **Made from extruded aluminium profiles and consists of two sections with a 35mm wide edge**
- **The inside edges of the grille are covered with acoustic foam**
- **Produced in lengths up to 1500mm**
- **The profile or gap interval must be a multiple of 85mm up to a maximum 935mm – 1 to 11 vanes**
- **The area of ventilation available is about 29% of the total grille plate area**



**USE**  
Can be easily mounted with screws onto a door or wall.

**ORDERING REFERENCES**

|     |                                |
|-----|--------------------------------|
| AVG | State size and finish required |
|-----|--------------------------------|

**ACOUSTIC PERFORMANCE**

|                 |   |
|-----------------|---|
| ISO140-3 (1995) | Maximum sound absorption at a minimal air-resistance (20 Pa) is achieved at an air speed no greater than 1.9m/s, calculated on the open passage of the grille, with measurement of the sound insulation |
|-----------------|---|

# Upgrading raised and fielded doors to FIRE rated status

The ES/RFC System (Product 103) has been designed to upgrade raised and fielded panelled doors. The system is ideally suited for refurbishment projects requiring existing period doors to be upgraded. Doors can be upgraded to either a FD30 or FD60 fire door classification dependant on the requirement issued by Building Control.

## FIRE PERFORMANCE

The ES/RFC system has been applied to a number of doors that have been tested in accordance with BS476 Part 22 (1987), assisting doors to achieve a fire integrity of between 30 and 60 minutes.



## IMPORTANT CONSIDERATIONS

If the door is to be stained, only use water-based stains before the application of the ES/RFC System. When the stain has dried, lightly rub down the substrate with glass paper, clean down and then begin to apply the ES/RFC system. Trials in small areas should always be carried out prior to the full application, as colour performance can vary according to substrate type.



**Do not apply these products in temperatures below 5°C**



**Only apply these products in areas where the atmospheric moisture is below 65%**



**Only apply these products on surfaces that have a moisture content below 17%**

## SPECIAL INSTRUCTIONS

### ES/RFC/IN/C Clear intumescent

ES/RFC/IN/C Clear needs to be stirred for 5 minutes before application. In cold temperatures stand the container in hot water and stir well – then apply.

Typical of intumescent, the ES/RFC/IN/C clear coating appears cloudy when first applied. As the coating dries it will become completely clear in finish. Allow the first coat to completely dry and clear before applying the second coating.

Once ES/RFC/IN/C Clear has been applied DO NOT ATTEMPT to rework by over brushing – this will tear the coating. If reworking is necessary then dip the brush in warm water and gently brush over the area.

If this is the first time ES/RFC/IN/C Clear has been applied, it is advisable to test on a small area.

It is crucial that ES/RFC/IN/C Clear is sealed with a top coat. This must be completed as soon as the ES/RFC/IN/C Clear coat is dry. Do not leave overnight to finish as the ES/RFC/IN/C Clear will absorb atmospheric moisture causing a cloudy appearance. This cannot be corrected without stripping back to the original surface. Only leave overnight in dry and heated rooms.

### ES/RFC/IN/W White intumescent

ES/RFC/IN/W White needs to be stirred for 5 minutes before application. In cold temperatures stand the container in hot water and stir well – then apply.

## CLEAR Fire Protection 30-60 mins Upgrading Raised and Fielded Doors

### ES/RFC CLEAR KIT

Preparation: The substrate surface must be clean of all dust and dry. There should be no trace of oil, grease or similar substance. The surface should be sanded smooth. If timber is pre-varnished, ensure the surface is clean and sanded appropriately.

#### PRIMER

##### ES/RFC/Primer ● Water-based

This coating is a water-based clear primer for use in areas in which other ES products could not normally be applied.

**Coating rate** 1 coat  
**Coverage** 10-12m<sup>2</sup> per litre

#### INTUMESCENT COATING

##### ES/RFC/IN ● Water-based

This coating is an intumescent water-based hygroscopic coating. As soon as this coat has dried a protective topcoat must be applied. Allow to dry thoroughly.

**Coating rate** For 30/60 mins of Fire Protection: apply 2 coats at 8m<sup>2</sup>/litre. When thoroughly dry, apply second coat at 8m<sup>2</sup>/litre.

As soon as these coats have dried apply one of the protective top coats shown below. Allow to dry thoroughly.

#### TOP COATS

##### ES/RFC/CM ● Water-based Matt

##### ES/RFC/CS ● Water-based Satin

These clear top coats are low-odour, quick drying, water-based polyurethane varnish ideal for areas that require a tough and high resistant protection. Designed for areas of high levels of traffic where doors require high levels of protection.

**Coating rate** 2 coats  
**Coverage** 10-12m<sup>2</sup> per litre per coat  
**Finish** Matt, Satin

4 – 5 year  
maintenance  
cycle

Each kit will cover 6m<sup>2</sup> or 3 of the risk sides of the door surfaces. Please see the price list for more information.



## COLOUR Fire Protection 30-60 mins Upgrading Raised and Fielded Doors

### ES/RFC COLOUR KIT

Preparation: The substrate surface must be clean of all dust and dry. There should be no trace of oil, grease or similar substance. The surface should be sanded smooth. If timber is pre-varnished, ensure the surface is clean and sanded appropriately.

#### PRIMER

##### ES/RFC/Primer ● Water-based

This coating is a water-based clear primer for use in areas in which other ES products could not normally be applied.

**Coating rate** 1 coat  
**Coverage** 10-12m<sup>2</sup> per litre.

#### INTUMESCENT COATING

##### ES/RFC/IN/W ● Water-based

This coating is an intumescent water-based hygroscopic coating. As soon as this coat has dried a protective topcoat must be applied. Allow to dry thoroughly.

**Coating rate** For 30/60 mins of Fire Protection: apply 2 coats at 8m<sup>2</sup>/litre. When thoroughly dry, apply second coat at 8m<sup>2</sup>/litre.

As soon as these coats have dried apply one of the protective top coats shown below. Allow to dry thoroughly.

#### TOP COATS

##### ES/RFC/WM ● Water-based Matt

##### ES/RFC/WS ● Water-based Satin

##### ES/RFC/WG ● Water-based Gloss

These top coats are white water-based hardwearing coating. Designed as a high quality internal coating for hardwearing and general use.

**Coating rate** 2 coats  
**Coverage** 10-12m<sup>2</sup> per litre per coat  
**Finish** Matt, Satin, Gloss

4 – 5 year  
maintenance  
cycle

Each kit will cover 6m<sup>2</sup> or 3 of the risk sides of the door surfaces. Please see the price list for more information.





# Product 38 Upgrading existing panelled doors to FD 30 - 60 fire rating

Fire doors act as a crucial element of the escape route protection in loft room extensions. If the doors meet the criteria shown on page 31 (Method A or B), then there is no need to discard them. Follow the instructions below and upgrade these doors to a full FD30 or FD60 where required!

## INTRODUCTION

The Envirograf® Panelled Door Upgrading System is simple to apply and offers effective results. This system has been used in many prestigious heritage buildings as part of major refurbishment projects. Envirograf® Product 38 has also been used in many loft conversions that are typically made in Victorian, Georgian and Edwardian homes, all containing beautiful original doors. Often these doors are replaced with modern FD rated replicas, which never have the original appearance.

The system comprises, an intumescent coating applied to the door and an intumescent sandwiched card (for doors to be painted) or an intumescent sandwiched veneer for doors to be varnished, applied to the risk side of the panels of each door to be upgraded.

## ROOM CONDITIONS AND CORRECT HUMIDITY FOR APPLICATION

Intumescent coatings require dry conditions to be effectively applied. Room humidity is crucial during application and drying time. **Atmosphere moisture readings should not exceed 65% RH.**

## IMPORTANT FOR DK KITS

After cleaning, if the door is still oily, greasy, or has wax on it, then a coating of Envirograf® Product 42 HW/AP Primer must be applied to the whole face of the door. Apply Envirograf® Product 93 Stabond to the panels and then apply Envirograf® Product 46 Intumescent adhesive (IA) to both the door panels and the grey side of the intumescent card/veneer/ply/gaboon.

Apply to the door panels and brush down flat, removing any air pockets, and then use a wallpaper roller to ensure good adhesion. Ensure that the supplied labels are fitted either on the edge of the door or frame over the top hinge on whichever side the intumescent seals are fitted to. All doors classed as fire doors should have intumescent fire and smoke seals fitted and intumescent paper behind the hinges and around rebated latches and locks. Envirograf® Product 69 surface-mounted 30 and 60 minutes fire and smoke protection seals are available (ES/SDS and ES/DDS), plus Envirograf® Product 100 rebated fire and smoke seals requiring a 10x6mm rebate in the edge of the door (CIS14/BS for 30 minutes and CIS15/BS for 60 minutes), and Envirograf® Product 71 intumescent paper for hinges (LPH) and latches/locks/closers (HP). Envirograf® Product 15 intumescent plugs are also available for hinge screws.

## UPGRADING FLAT PANELLED DOORS TO FIRE DOORS

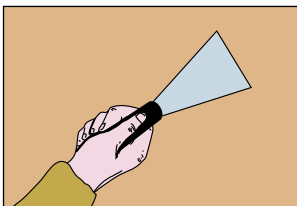

**1.** Scrape off all loose paint (not applicable for stained or polished doors)

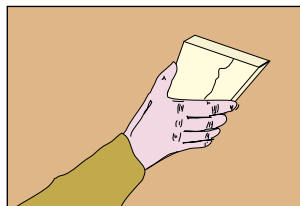

**2.** Thoroughly rub down the door panels (inc. corners and edges) with coarse glass paper, providing a good key for the adhesive

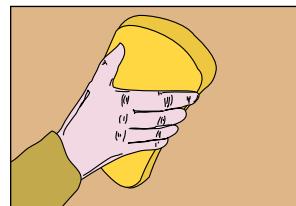

**3.** Thoroughly clean the panels, stiles, and rails of the door. Then coat the panels with the supplied Envirograf® Product 93 (Stabond)

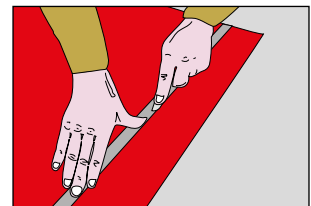

**4.** Measure the panel size and cut out the veneer/ card required



**5.** Apply product 93 Envirograf® Stabond, once dried apply Adhesive Product to the grey contact side of the card or veneer/plywood and the panel area

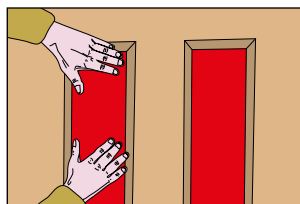

**6.** Apply the veneer/ card or fire card to the panel

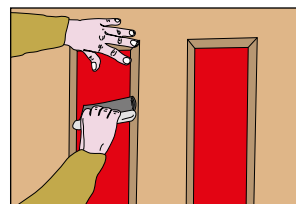

**7.** Using a flexible spatular firmly press the veneer/ card to the panel ensuring absolute contact over the whole surface



**8.** An example of existing panel doors fully upgraded to Fire Rated Doors

## UPGRADING EXISTING PANELLED DOORS CONTINUED

### METHOD A: FOR DOORS 30-34MM

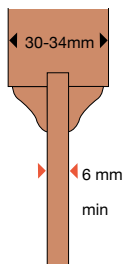

Intumescent card for painted panelled doors. This method is for doors with rails and stiles 30-34mm, with a minimum 6mm panel thickness. Cut the intumescent card to the panel size(s) and then coat the panels with Product 93 Stabond and allow to completely dry. Then apply, using a comb applicator, Product 46 intumescent adhesive (IA) to the grey contact side of the card and panels. Offer up the panels to adhere using a roller to ensure that there are no air bubbles and that the contact is uniform.

Any surplus adhesive that seeps out of the side can be removed with a finger or slightly damp cloth. Then apply two coats of Envirograf® Product 42 HW01/F white intumescent coating at 8m<sup>2</sup> per litre per coat to the stiles, rails, mullions, and beads, but **DO NOT PAINT THE CARD**. In a warm area, each coat should dry in one hour. When dry, apply one coat of Envirograf® Product 42 HW04/S spirit-based undercoat to the card only. When dry, apply one coat of HW Premier White/Colour top coat at 10-12m<sup>2</sup> per litre to the whole door (matt, satin, or gloss).

### DOORS WITH A CLEAR WOOD FINISH

Similar to the painted doors method above, except as follows. After cleaning off the panels and application of Stabond, cut the intumescent veneer/ply/gaboon to the panel size(s). Apply Envirograf® Product 46 intumescent adhesive (IA) to the door panel and back of the veneer (use Thixotropic high-strength adhesive for ply and gaboon) using a comb applicator and adhere to the door panels. Leave for one hour. If the door is already varnished, apply one coat of Envirograf® Product 42 HWAP/WB Primer at 12-14m<sup>2</sup> per litre to the stiles, rails, mullions, and beads but **DO NOT COAT THE PANELS**. HWAP/WB Primer is not necessary on untreated new wood. Once the HWAP/WB Primer is dry, apply two coats of Envirograf® Product 42 HW02/E clear coating at 8m<sup>2</sup> per litre per coat. In a warm area, each coat should dry in about 45 minutes. Then apply one top coat: Envirograf® Product 42 HW/Premier Clear (matt, satin) 10-12m<sup>2</sup> per litre to the whole door.

### METHOD B: FOR DOORS OVER 35MM

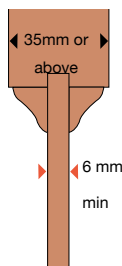

Intumescent card for painted panelled doors. For doors with stiles and rails 35mm or more. Owing to the thickness of the stiles, rails, and mullions, there is no need to coat them or the intumescent card or ply with intumescent coating. Preparation as for Method A except that when you have applied the intumescent card to the door panels, you only need to treat the beads with two coats of Envirograf® Product 42 HW01F white intumescent coating at 8m<sup>2</sup> per litre per coat. Then apply one coat of Envirograf® Product 42 HW04/S spirit-based undercoat before application of a top coat to the whole door (including the panels) in the colour and finish you require.

### DOORS WITH A CLEAR WOOD FINISH

For doors with stiles and rails 35mm or more. Application as for intumescent card above. Owing to the thickness of the stiles, rails, and mullions, there is no need to coat them or the intumescent card/veneer/ply/gaboon with intumescent coating. Preparation as for Method A except that when you have applied the intumescent card/veneer/ply/gaboon to the door panels, you only need to treat the beads with one coat of Envirograf® Product 42 HWAP/WB Primer (new or dipped doors do not require this), then two coats of Envirograf® Product 42 HW02/E clear intumescent coating at 8m<sup>2</sup> per litre per coat. In a warm area, each coat should dry in about 45 minutes. Then apply one top coat of Envirograf® Product 42 HW/Premier Clear (matt and satin) at between 10-12m<sup>2</sup> per litre.

### NOW AVAILABLE IN KIT FORM

|                    |        |             |              |
|--------------------|--------|-------------|--------------|
| <b>ES/MP/DK2C</b>  | White  | 0900x1350mm | Mat/Firecard |
| <b>ES/MP/DK2/P</b> | Pine   | 1200x1200mm | Pine Veneer  |
| <b>ES/MP/DK2/O</b> | Oak    | 1200x1200mm | Oak Veneer   |
| <b>ES/MP/DK3</b>   | Gaboon | 1200x1200mm | Gaboon       |

More veneers are available. See price list.

## DOOR MANUFACTURING SYSTEM: intumescent cloth sandwiched between timber panels

For manufacture of panelled doors, either flat panelled or raised-and-fielded panelled doors, giving 30 minute doors. The thickness of the stiles and rails can be from 36mm upwards, with panel areas made from two 6mm thick flat panels with Envirograf® Product 38 (ES/MP) cloth sandwiched between them and adhered together with Envirograf® Product 46 intumescent adhesive (IA). The procedure is the same for raised-and-fielded panels, where each side of the fielded area is 6mm thick. Stiles and rails can be 35mm down to 30mm thickness if coated with Envirograf® Product 42 (HW02/E clear or HW01/F white intumescent coating) followed by Envirograf® Product 42 clear or coloured top coats.

For 60 minutes fire protection, the thickness of the stiles and rails must be from 44mm to 52mm, with panel areas made from two 12mm thick flat panels with Envirograf® Product 38 (ES/MP) cloth sandwiched between them and adhered together with Envirograf® Product 46 intumescent adhesive (IA). For raised-and-fielded panels, the fielded area with the cloth should be not less than 9mm thick.

**IMPORTANT: panels in all cases must be rebated into the stiles, rails, and mullions to a depth of 15mm.**

Envirograf® Product 38 (ES/MP) cloth can be laminated between two 12mm thick tongued-and-grooved timbers to make a ledged-and-braced door for 30 minutes fire protection or Product 38 (ES/MP) cloth can be laminated between two 18mm thick tongued-and-grooved timbers to make a ledged-and-braced door for 60 minutes rating.

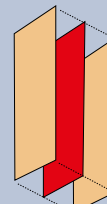
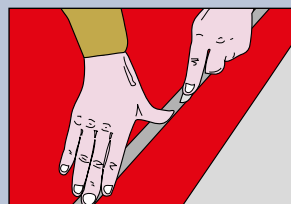

1. Measure and cut the Envirograf® Product 38 ES/MP intumescent material to match the panel sizes.

2. Sandwich ES/MP material between timber panels, adhering with Product 46 (IA adhesive). Then manufacture doors, ensuring that panels are rebated into a depth of 15mm and all beads are fixed with pins.