

CRAYLER F3 Series

PALFINGER CRAYLER



KTL
protected

3 years
warranty^{*)}

Reliable forklifts for demanding customers

Powerful and manoeuvrable...

We'll solve your transport problems - no matter how difficult the conditions may be. Use our unique industry-specific solution skills combined with the security of a globally successful company. CRAYLER transportable forklifts prove themselves in a wide variety of assignments.



... gets there faster



Pioneering technology



CRAYLER F3 151 PRO

Examples of use:

- Beverages and foodstuffs
- Transporting rolls of carpet

Features:

- Sensitive traction drive for delicate loads
- Lowest possible dead weight



CRAYLER F3 153 PRO

Examples of use:

- Potting composts and garden products
- Supermarket facilities
- Lightweight building materials (e.g. insulating materials)

Features:

- The lightest all drive forklift on the market



CRAYLER F3 201 PRO

Examples of use:

- Recycling
- Workshop waste disposal
- Gases

Features:

- Powerful and manoeuvrable



CRAYLER F3 203 PX

Examples of use:

- Medium-weight building materials (e.g. bricks, roofing materials)
- Recycling (electrical waste, hazardous substances)
- Technical and medical gases

Features:

- Flexible and versatile
- Unloading from one side - daily job



CRAYLER F3 253 PX

Examples of use:

- Heavy building materials (e.g. concrete building materials, glass, mini silos)
- Energy suppliers

Features:

- The best dead weight to payload ratio
- 2.5 t lifting power in front of the wheels - guaranteed!

Strong, flexible and reliable

CRAYLER F3 203 4W / 253 4W

Examples of use:

- Sawn timber
- Sections and pipes
- Various long products

Features:

- Excellent visibility to all sides
- Transport long and bulky goods safely



CRAYLER F3 203 GT-S

Examples of use:

- Gates and doors
- Transporting motor bikes
- Heating pellets

Features:

- The lightest transportable forklift with scissor-reach
- Disposable pallets and special racks frequently require a slim fork and the F3 203 GT-S



CRAYLER F3 253 GT-S

Examples of use:

- Heavy building materials (e.g. precast concrete components)
- Agricultural goods

Features:

- The transportable forklift for rough terrain
- Huge extension of the scissor-reach makes it easy to unload from one side of the vehicle



CRAYLER F3 203 GT-S 4W / 253 GT-S 4W

Examples of use:

- Solar technology
- Sawn timber, sections, pipes, etc.

Features:

- Fast scissor-reach system
- Rapid activation and deactivation of the 4-way mode - saves time and money on a daily basis



MOUNTING OPTIONS:

All CRAYLER F3 models fit on common

- Sliding beam mounts
- Chain mounts



Technical data ...

CRAYLER F3 151 PRO

Load	1500 kg/600 mm
Engine	3 cylinder diesel engine
Lifting height	2200 to 2850 mm
Dead weight	from 1340 kg (without forks)

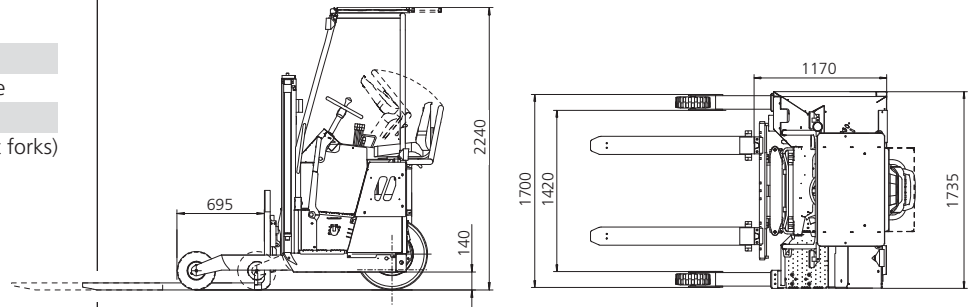

CRAYLER F3 153 PRO

Load	1500 kg/600 mm
Engine	3 cylinder diesel engine
Lifting height	2850 mm
Dead weight	from 1440 kg (without forks)

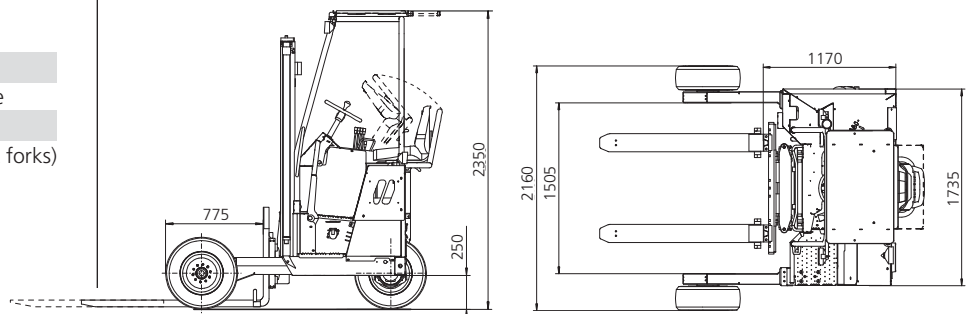

CRAYLER F3 201 PRO

Load	2000 kg/1300 mm
Engine	3 cylinder diesel engine
Lifting height	2850 to 3700 mm
Dead weight	from 1635 kg (without forks)

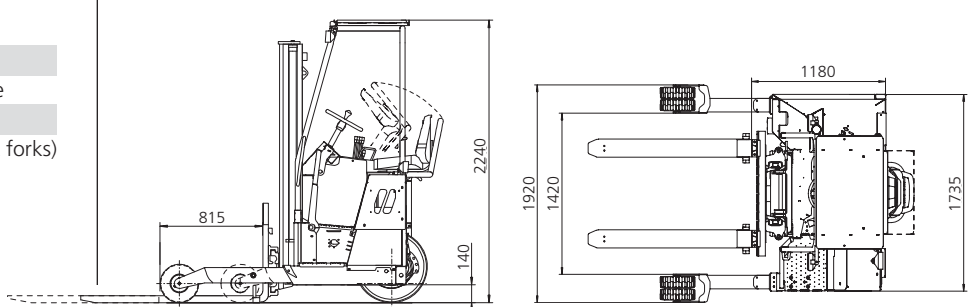

CRAYLER F3 203 PX

Load	2000 kg/1370 mm
Engine	3 and 4 cylinder diesel engine
Lifting height	3100 to 3700 mm
Dead weight	from 1660 kg (without forks)

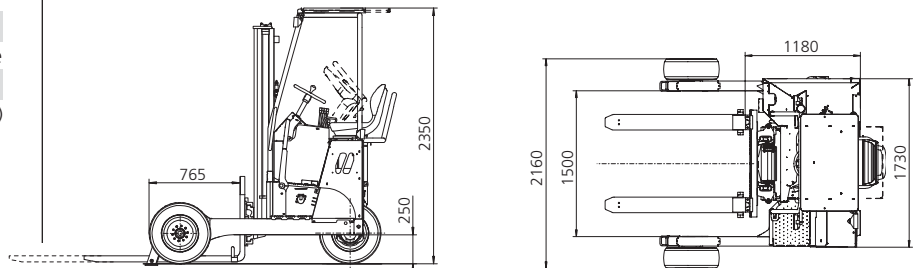

CRAYLER F3 253 PX

Load	2500 kg/1450 mm
Engine	3 and 4 cylinder diesel engine
Lifting height	3100 to 3700 mm
Dead weight	from 1755 kg (without forks)

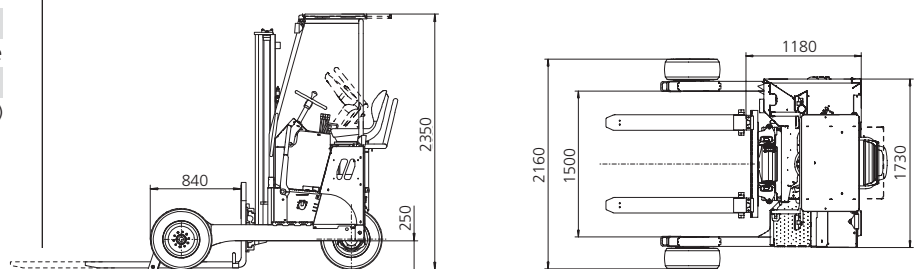

... optimised for practical use

CRAYLER F3 203 4W / 253 4W

Load	2000/2500 kg/1300 mm
Engine	4 cylinder diesel engine
Lifting height	2850 to 3700 mm
Dead weight	from 1820 kg (without forks)

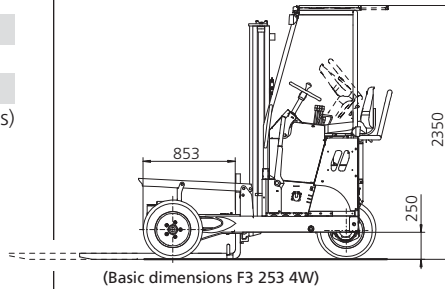

(Basic dimensions F3 253 4W)

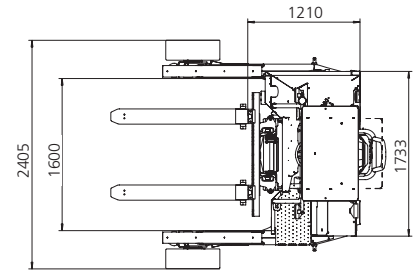

CRAYLER F3 203 GT-S

Load	2000 kg/1400 mm
Engine	3 and 4 cylinder diesel engine
Lifting height	3100 to 3700 mm
Dead weight	from 1850 kg (without forks)

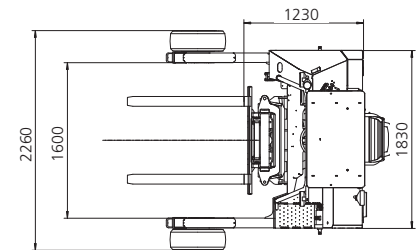
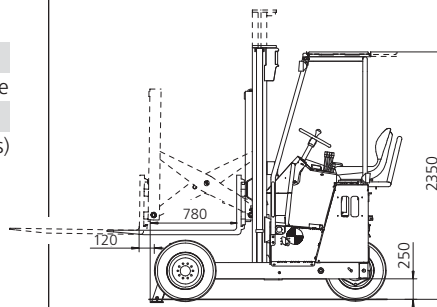

CRAYLER F3 253 GT-S

Load	2500 kg/1400 mm
Engine	4 cylinder diesel engine
Lifting height	3100 to 3700 mm
Dead weight	from 2215 kg (without forks)

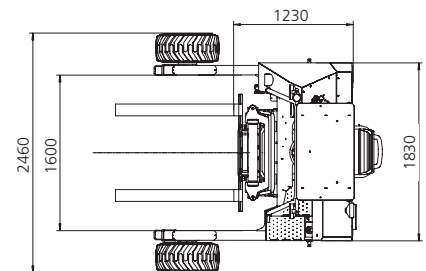
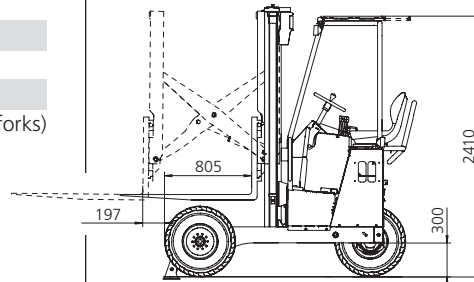

CRAYLER F3 203 GT-S 4W / 253 GT-S 4W

Load	2000/2500 kg/1400 mm
Engine	4 cylinder diesel engine
Lifting height	3100 to 3700 mm
Dead weight	from 1920 kg (without forks)

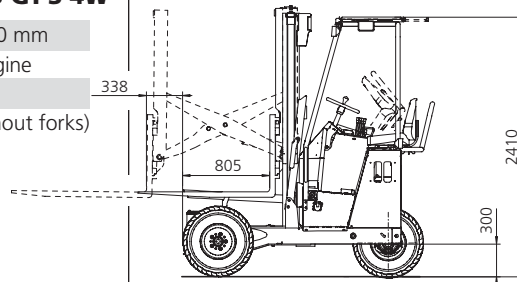

(Basic dimensions F3 253 GT-S 4W)

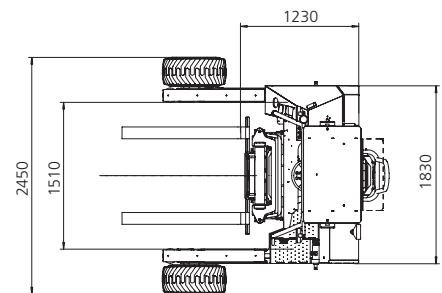

MOUNTING OPTIONS

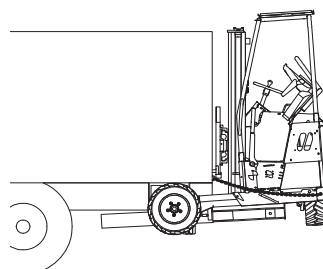

Sliding beam mounts

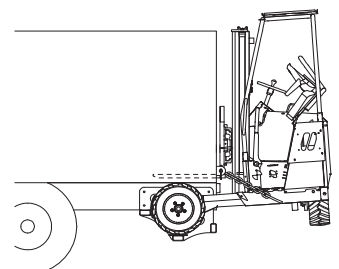

Chain mounts

Arguments that are convincing



Safety and comfort

- Due to generous legroom
- Centrally located seat



Fatigue-free, fast working ability

- Due to ergonomically arranged controls
- Clearly laid out, easy push-button operation
- Easy to handle, good-sized steering wheel



Maximum manoeuvrability and long service life

- Due to 180° steering angle
- High-quality, powerful drives



Best possible corrosion protection and long-term value retention

- Due to extensive pre-treatment of surfaces
- Complete cathoretic dip painting (key process) and subsequent powder coating process
- Double chrome-plated piston rods



Best all-round visibility

- Clearview mast makes light work of every assignment

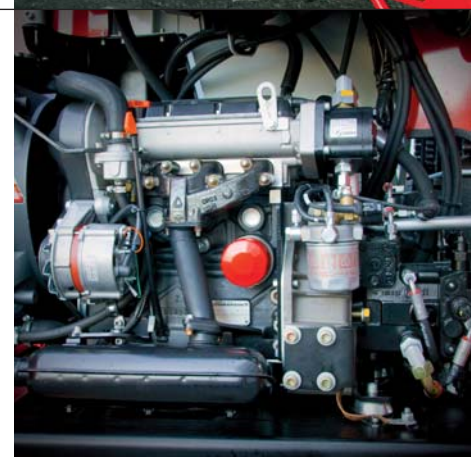

Simple, time-saving maintenance

- Due to clearly arranged and easily accessible inspection and maintenance points
- Flange-mounted pumps
- In addition to reliable and stable technology



Rapid assistance anywhere, any time

- 24-hour service
- 1,500 PALFINGER service support points worldwide
- Qualified customer service employees



Low dead weight and well-protected components

- Due to compact design and enclosed chassis construction
- Simple electrics
- Reliable and stable technology