

MCP Series Wormwheel Gearboxes

The most competitive ruggedised wormwheel gearboxes on the market can be supplied with or without AC/DC motors.

A quality, high power to weight ratio, low noise and reliable gearbox is robustly constructed in either ruggedised die-cast aluminium or composite materials (high strength plastic) make MCP gearboxes the obvious first choice.

MCP 2

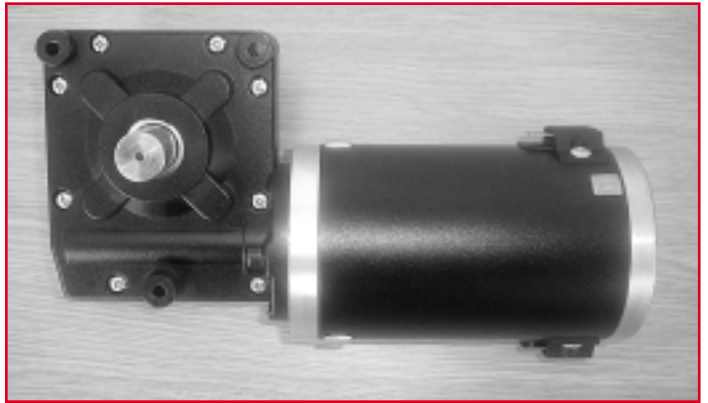

Ratios:

12:1, 25:1, 30:1, 50:1, 60:1
Other ratios available on request

Features and Options

- Compatible with ZYT DC Series Motors
- Extensive Range of Ratios
- Customised shafts to suit any application including:-
 - Variable Diameters
 - Hollow shafts
 - Machined ends
- Delrin®, Phosphor Bronze and Steel Gears
- Available in ruggedised die-cast aluminium or composite materials (high strength plastic)
- Lubricated for life
- Designed for Low Noise operation

ZYT Motor/Gearbox Configurator									
Motor Dia. in mm	Motor Length in mm	Volt. DC	Gearbox	Ratio	Option One	Option Two	Option Three	Option Four	Option Five
See Separate Motor Chart for Specifications			MCP4		AD	DR	BK	EC	CS##
			MCP2		CM	BZ	MRB		
						ST			

Example:

ZYT80 147 24 MCP4 25:1 AD DR MRB EC CS##

- Key:**
- AD = Die-cast Aluminium Housing
 - CM = Composite Material Housing (high strength plastic)
 - DR = Delrin® Gears
 - BZ = Bronze Gears
 - ST = Steel Gears
 - BK = Electric Brake
 - MRB = Electric Brake with Manual Release
 - EC = Rubber End Cover
 - CS = Custom Shaft followed by customer number

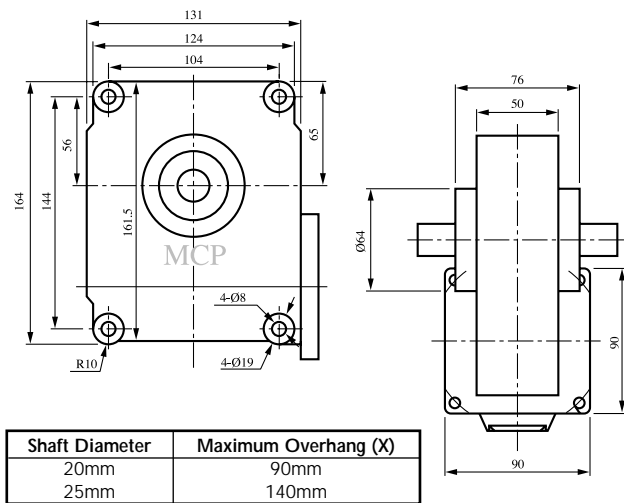

MCP 4

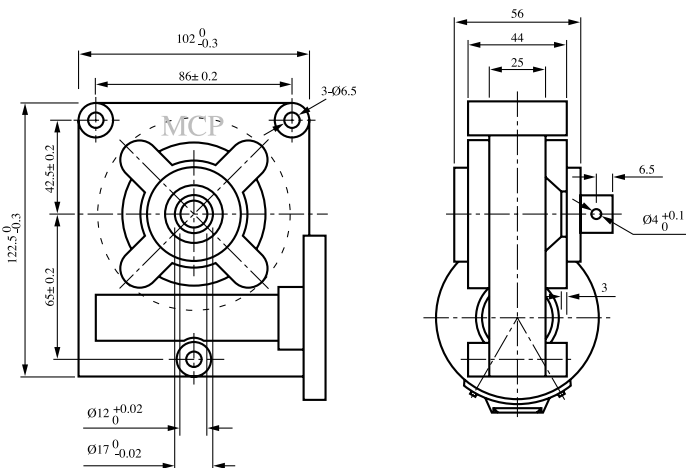

N.B. stall torque = 2.5 x continuous rated torque • All dimensions in millimetres • Drawings not to scale • MCP reserve the right to change specifications



11-15 FRANCIS AVENUE, WALLISDOWN,
BOURNEMOUTH BH11 8NX, ENGLAND
Tel: +44 (0) 1202 599922 Fax: +44 (0) 1202 599955
Website: www.motioncontrolproducts.com
E-mail: sales@motioncontrolproducts.com