

A-A (1:30)

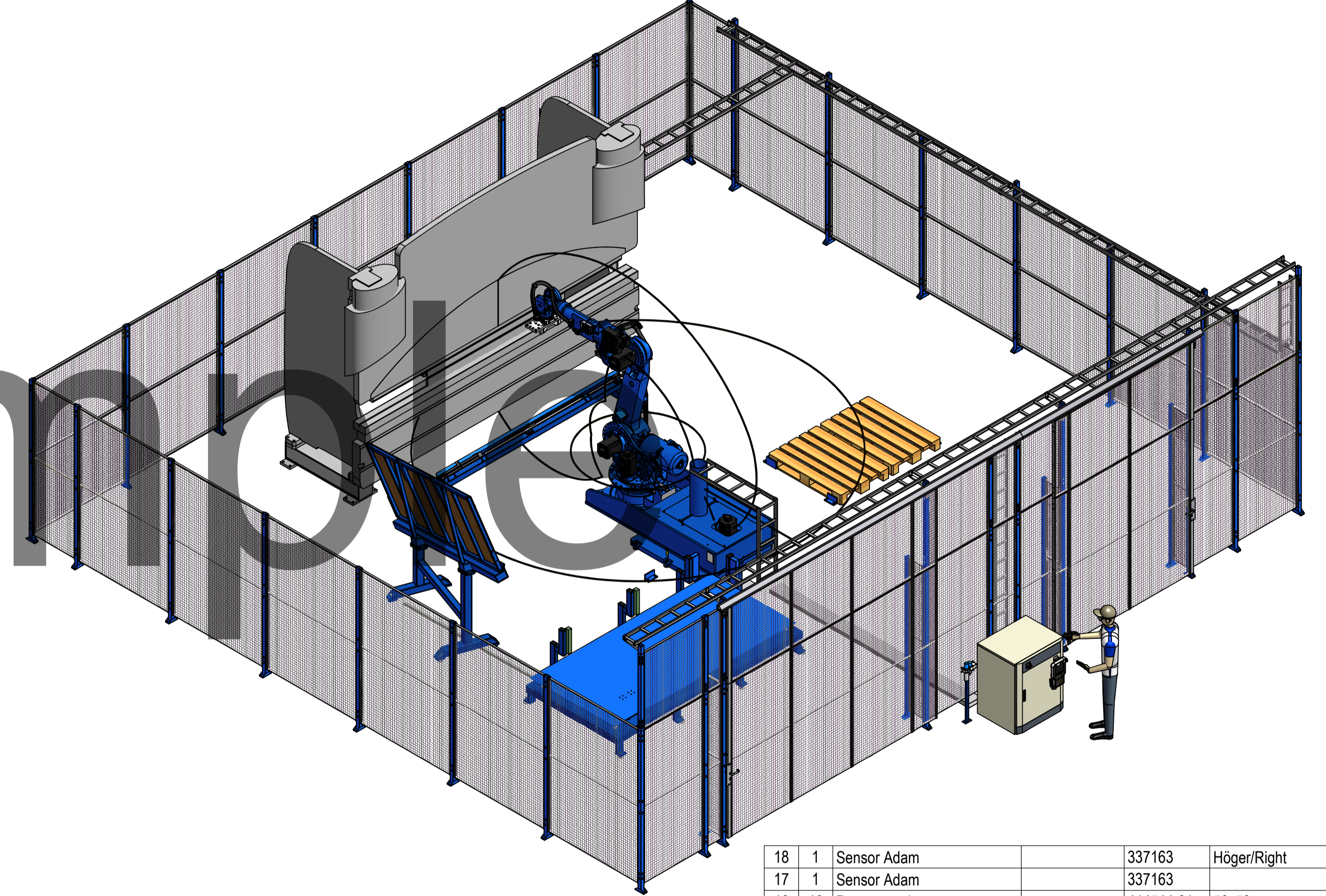
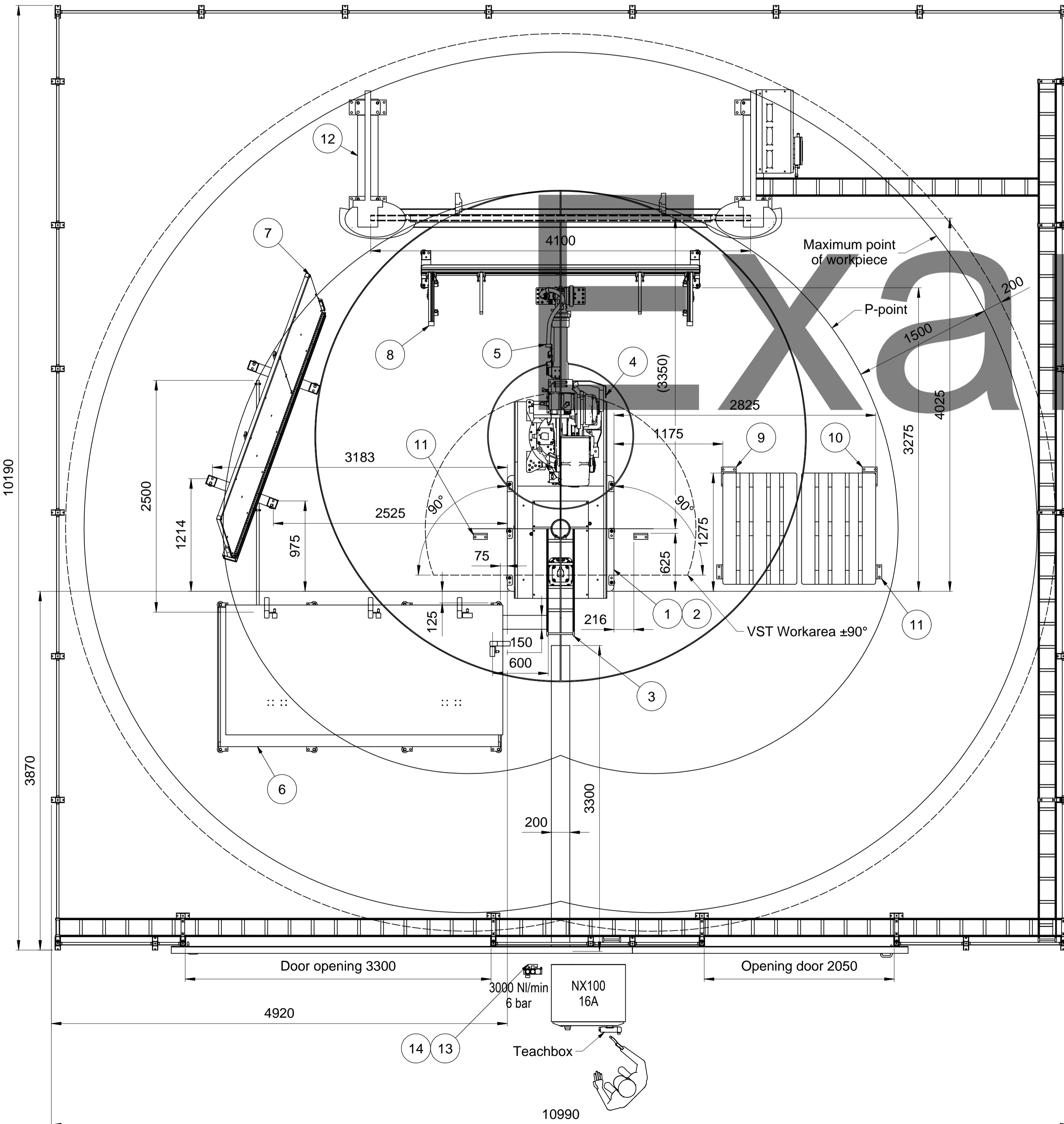
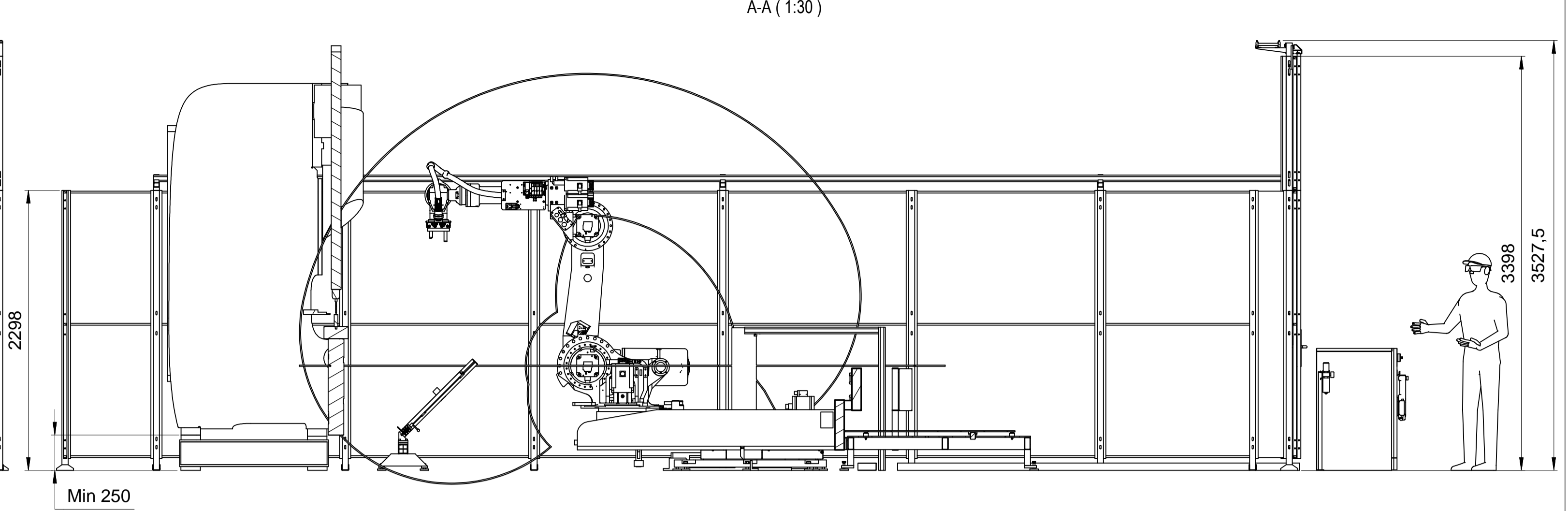
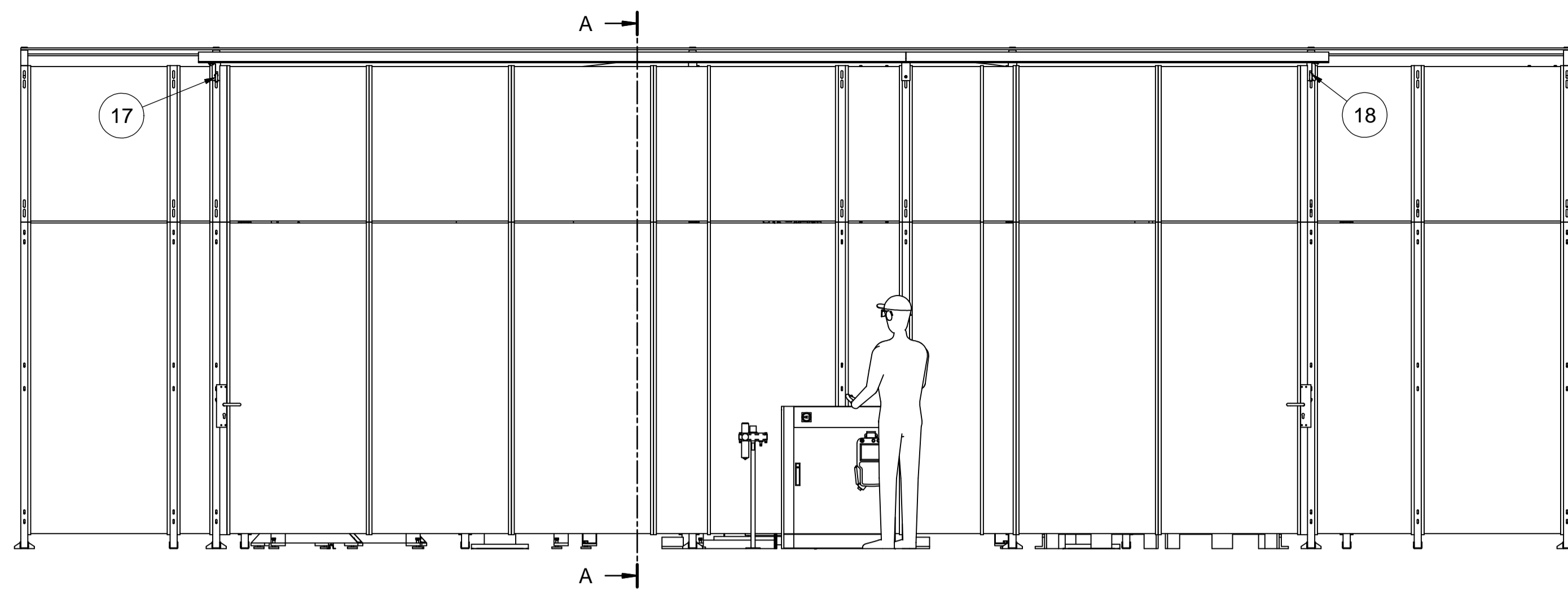

Cable ladder

- 7 pieces 8170000 Cable ladder L=4000 W=200
- 10 pieces 8170010 Console 50/200
- 20 pieces 8170100 Clamb 42
- 8 pieces 8170101 Connection
- 2 pieces 8170103 Angle bracket
- 2 pieces 8170104 Angular hook
- 6 pieces 8170106 Wall bracket 11/25
- 12 pieces 8170108 Cover

Cable ducts

- 1 piece 209008-01 Cable duct L=2000 W=150
- 1 piece 209008-02 Cover L=2000 W=150
- 2 pieces 209008-11 Cable duct L=2000 W=200
- 2 pieces 209008-12 Cover L=2000 W=200
- 2 piece 8020035 Cable cover L=1700
- 3 pieces 8020036 Bracket

Cables and hoses

- Robot cables 9m
- VST servocables 9m
- 1/2" Air hose from service unit to robot base 9m

Layout Godkänd / Layout Approved

Kund / Customer.....

Datum / Date.....

Signerad / Signed.....

Signerad / Signed.....

18	1	Sensor Adam	337163	Höger/Right
17	1	Sensor Adam	337163	
16	10	Post extension	414544-81	50x50
15	1	Safety guarding	137105-102	
14	1	LFR-Unit	7027932	LFR-12-D-MIDI-KB
13	1	Console service unit	358009	
12	2	Foundation		H at least 250mm
11	4	Stop	253610	
10	1	Stop	254215-81	
9	1	Stop	254215-80	
8	1	Regripping station	137010-84	L=3000
7	1	Orientation table	137007-82	
6	1	Location table	137034-88	L=3040 Left/Vänster
5	1	Install kit	137092-100	ES165N I/O 1 Pol
4	1	ES165N		
3	1	Cable bearer	255769	
2	1	Cam	316377-100	
1	1	VST-1500SN	115015-100	

Main drawing		Proj. nr. / Proj. no.	Art. nr. / Art. no.	Material/Lev. nr. / Material/Supplier	Art. nr. / Art. no.	Rev. nr. / Rev. no.	Beskrivning/Anmärkning / Description/Remark
Proj. nr. / Proj. no.	Art. nr. / Art. no.	Proj. nr. / Proj. no.	Art. nr. / Art. no.	Material/Lev. nr. / Material/Supplier	Art. nr. / Art. no.	Rev. nr. / Rev. no.	Beskrivning/Anmärkning / Description/Remark
Kund / Customer		Pressbrake ES165N		Konsult / Consultant		HAP	
Datum / Date		A1		Konsult / Consultant		HAP	
Signerad / Signed		A1		Konsult / Consultant		HAP	
Signerad / Signed		A1		Konsult / Consultant		HAP	
MOTOMAN		A1		Konsult / Consultant		HAP	
A YASKAWA COMPANY		A1		Konsult / Consultant		HAP	
WorkInProgress		A1		Konsult / Consultant		HAP	
1:30		A1		Konsult / Consultant		HAP	
137103-100		A1		Konsult / Consultant		HAP	

MOTOMAN ROBOTICS EUROPE AB

This document is the property of Motoman Robotics Europe AB. It is intended for use by the customer for the specific project only. It is not to be used for any other purpose. All rights reserved. © 2014 Motoman Robotics Europe AB.