

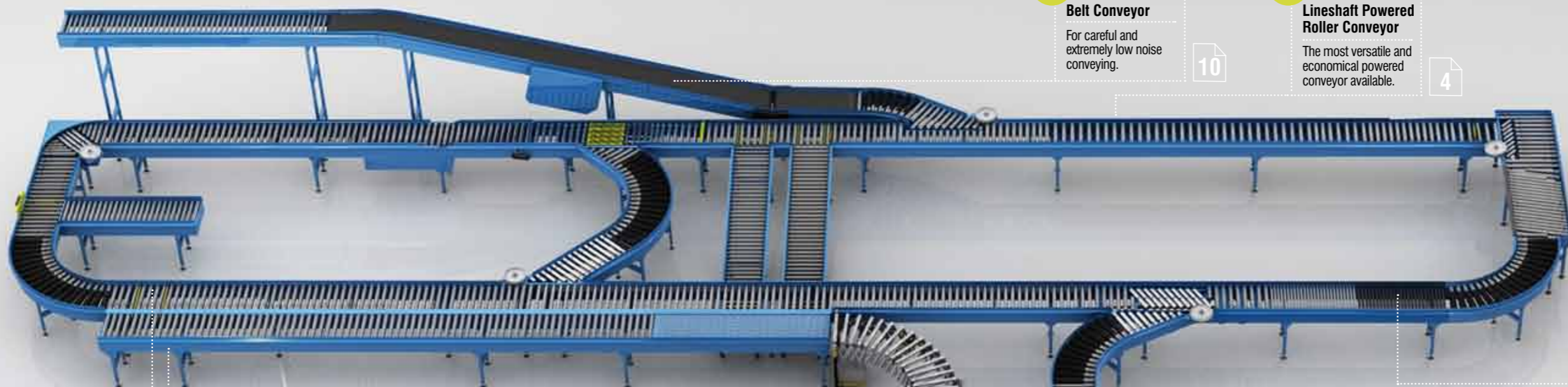

**conveyor solutions**



**Quality • Performance • Reliability**



**4**  
**Belt Conveyor**  
 For careful and extremely low noise conveying. 10

**1**  
**Lineshaft Powered Roller Conveyor**  
 The most versatile and economical powered conveyor available. 4

**6**  
**Belt Under Roller Conveyor**  
 Can achieve exceptionally high speeds and throughput rates. 14

**2**  
**Motorised Roller Conveyor - Zero Line Pressure**  
 A low maintenance, low energy conveyor due to minimum moving parts. 6

**5**  
**Gravity Conveyor**  
 The most cost-effective conveying solution. 12



**3**  
**Pallet Handling Conveyor**  
 Designed for flexibility and heavy duty usage - up to 1500kg per pallet. 8

**7**  
**Flexible Conveyor**  
 For increased efficiency in loose loading and unloading of vehicles. 16



Quality

Performance

Reliability



**Introduction**

The uni-xu® range of conveyors has been integral to thousands of turnkey solutions for some of the most demanding and successful companies across Europe. It is renowned for the robustness of its design, with quality being reflected in a distinct durability in the field. Furthermore, the modularity of the uni-xu® design offers extreme flexibility and simplicity for totally integrated systems. It has been engineered and manufactured in Britain since 1963, resulting in five decades of engineering development and excellence, which today, makes it one of the best known trademarks in conveyor manufacture.

**Facts**

- UK's largest conveyor manufacturer. ● 150,000 sq. ft. manufacturing plant on a 7 acre site.
- In excess of half a million rollers manufactured every year. ● Over 15 km of conveyor produced each year.
- Over a third of conveyor orders shipped overseas.



# Lineshaft Powered Roller Conveyor



- The most versatile and economical conveyor available in material handling.
- The more complex the configuration of conveyors, the fewer drives are required compared to conventional equipment.
- One of the unique advantages of Lineshaft Powered Roller Conveyor is the number of ancillary modules which can be driven from one motor by means of couplings and universal joints.
- Easily reconfigured to meet current demands and future challenges.

Key Features	Benefits
Modular design.	Proven product, highly configurable, easy and reduced installation with low maintenance. Allows for a variety of arrangements to be made from standard components.
Ability for transportation and accumulation on the same conveyor system.	Versatility / adaptability in product handling. Optimised productivity.
Fewer motors required.	Reduced costs in installation, maintenance and power consumption.
Ability to include ancillary items.	Highly adaptable / versatile and cost-efficient.
Accumulation.	Reliable accumulation thus eliminating product damage. Easily reconfigurable if further ancillary items are added.
Quiet.	Reduced noise is more conducive to good working environment.
Heavy duty drive belts on bends, merges and mitres.	Increased driving capacity.

### Ancillary modules include:

- Bends
- Switch Sorters
- Lift Up Gates
- Merges
- Switch Units
- Stops
- Line Brakes
- Transfers
- Pusher Unit
- 90° Roller Junctions

### Available in:

- Powder coated as standard
- Aluminium
- Stainless steel

### Specification

Model	Drive Capacity Per Roller	Roller Diameter	Roller Pitch	Standard Track Widths	Standard Speeds (metres per minute)
XU30 XU30S Light Duty	4kg (3mm dia. belt)	35mm	37.5mm	412mm	12 / 15 / 19 / 24 / 29
				462mm	
				512mm	
				612mm	
XU60 Med. Duty	8kg (4.75mm dia. belt)	50mm	75mm, 100mm or 150mm	412mm	12 / 15 / 19 / 24 / 29
				462mm	
				512mm	
				612mm	
XU90 Heavy Duty	12kg (5.3mm dia. belt)	50mm	75mm, 100mm or 150mm	412mm	12 / 15 / 20 / 25 / 30
				462mm	
				512mm	

• Non standard widths available.

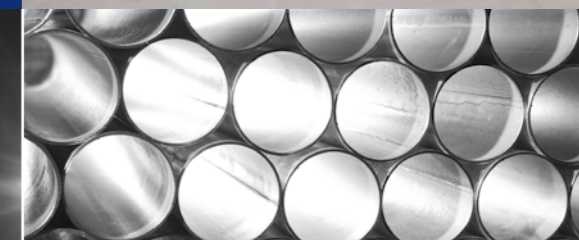

2

## Motorised Roller Conveyor - Zero Line Pressure

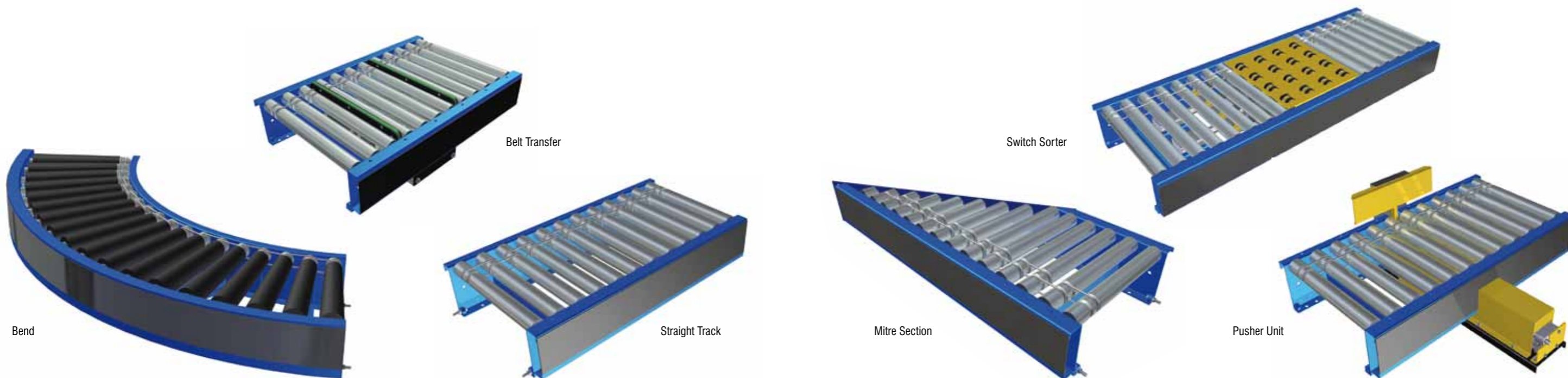

- A low maintenance conveyor, due to minimum moving parts.
- Offers extreme versatility in the transportation of various totes / cartons, whilst providing ultra-efficient accumulation.

Key Features	Benefits
Modular design.	Proven product, highly configurable, easy and reduced installation with low maintenance. Allows for a variety of arrangements to be made from standard components.
Low voltage 24V DC brushless motorised drive rollers.	Low energy consumption providing energy efficient conveying. Low noise.
Run on demand.	Energy conservation. Increases component life.
Zero line pressure accumulation.	No contact between loads. Eliminates product damage from pressured accumulation alternatives.
Plug and play options / photocells.	Pre-mounted and pre-wired electrical components, resulting in reduced electrical installation times and costs.
Complete or partial integration of accumulation modules.	Allows for transportation or accumulation as required.

### Ancillary modules include:

Bends  
Switch Sorters  
Lift Up Gates  
Mitre Sections  
Pusher Unit  
Belt Transfer

### Available in:

Powder coated as standard  
Aluminium  
Stainless steel

### Specification

Drive Capacity Per Roller	Roller Diameter	Roller Pitch	Standard Track Widths	Standard Speeds (metres per minute)
8kg per roller	50mm	75mm, 100mm and 150mm	412mm 462mm 512mm 612mm 762mm 912mm	Up to 55

- For heavier loads and higher speeds, please contact our Sales Office.



3

## Pallet Handling Conveyor

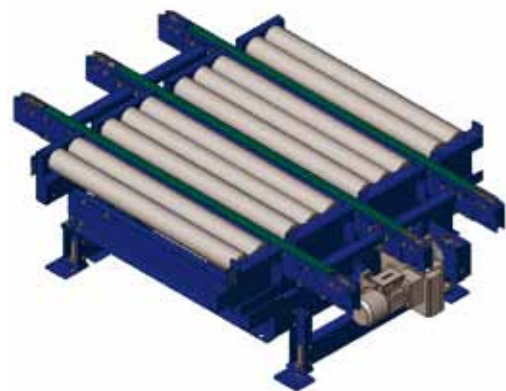

Centre Transfer



Chain Straights



Roller Straights



Roller Turntable

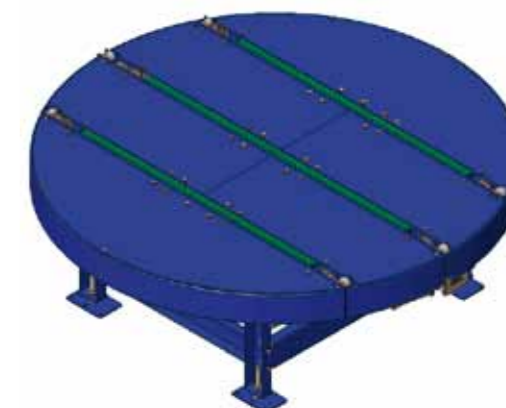

Chain Turntable

- Designed for flexibility and heavy duty usage - up to 1500kg per pallet.

Key Features	Benefits
Modular design.	Proven product, highly configurable, easy and reduced installation with low maintenance.
Up to 4500kg can be conveyed with only one drive.	Allows for a variety of arrangements to be made from standard components.
Robust construction with formed steel frame profiles.	Economical.
Closed channel design on both the roller and chain conveyors.	Strong and long lasting.
Tangentially driven rollers.	Ability to fit facia or photo-cells anywhere along frame via clamp brackets.
Two and three strand chain conveyor beds.	Smooth and gentle transportation - minimum backlash, low maintenance.
Transfer uses only triple strand chains.	Cost effectiveness for the weight being conveyed.
Chain tension accessed and adjusted quickly without the need for removing any guards.	Maximum resilience and reliability.
	Time-saving and easier maintenance.

### Ancillary modules include:

Roller Conveyor  
Chain Conveyor  
Transfers  
Turntables  
Motor Roller Options  
Side Load Sections  
Pallet Entry Guides  
Fork Lift Truck Stops  
Bridging Kits

### Available in:

Powder coated as standard

### Specification

Load	Roller Diameter	Roller Pitch	Standard Track Widths	Standard Speeds (metres per minute)
800W x 1200L Europallet Max weight 1000kg	80mm	200mm	952mm	12 / 18
1000W x 1200L Chep Pallet Max weight 1500kg	80mm	150mm	1152mm	12 / 18

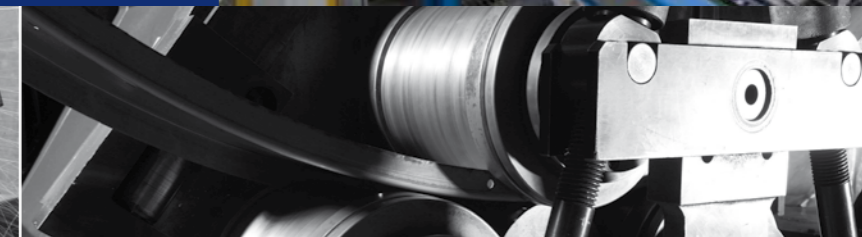

# 4

## Belt Conveyor



Type A Belt Conveyor (End-Drive)



Type B Belt Conveyor (Intermediate Drive)

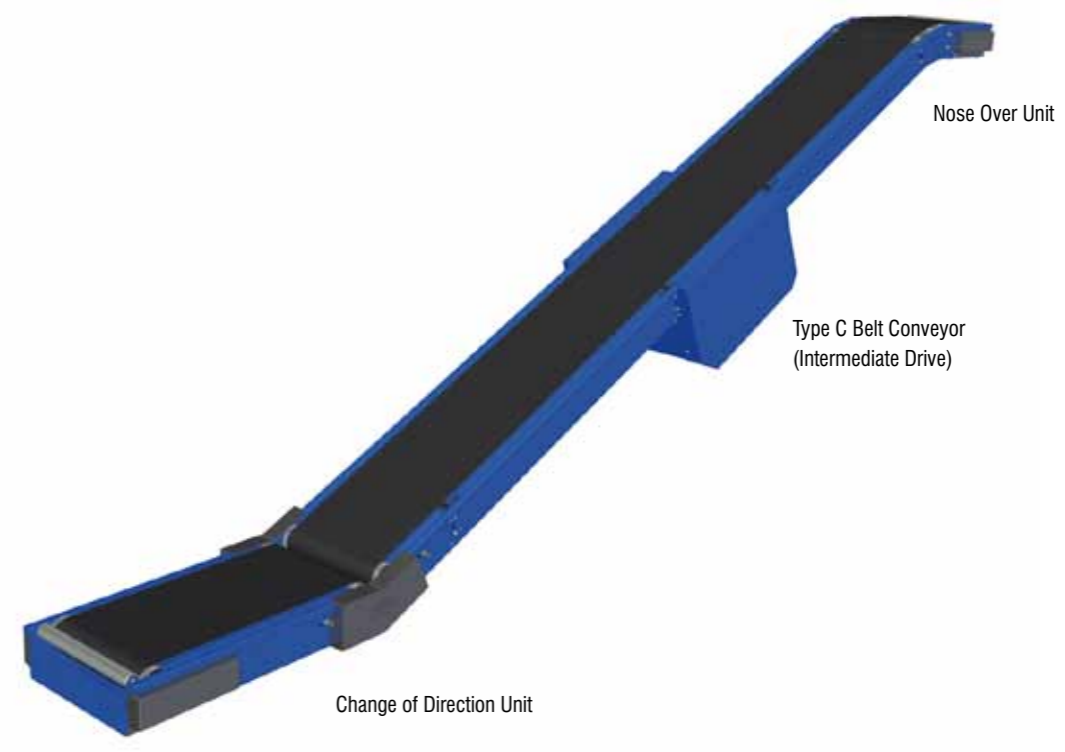

Change of Direction Unit

Type C Belt Conveyor (Intermediate Drive)

Nose Over Unit

- For careful and extremely low noise conveying – horizontal or incline / decline.

Key Features	Benefits
Modular design.	Proven product, highly configurable, easy and reduced installation with low maintenance. Allows for a variety of arrangements to be made from standard components.
Fully reversible option (with intermediate drive).	Greater versatility with the intermediate drive.
Fewer number of components with reduced adjustments.	Low initial cost, reduced spare parts cost, ease of installation and maintenance.
Roller bed.	Lowers power requirement, conserves energy.
Slider bed.	Quiet operation, smooth transportation.

- Ancillary modules include:**
- Mobile Units
  - Pop-Out Rollers
  - Change of Direction
  - Nose Over Units
  - End-Drive / Intermediate Drive
  - Comprehensive range of belt types

- Available in:**
- Powder coated as standard
  - Aluminium
  - Stainless steel

**Specification**

Load	Belt Widths	Standard Speeds (metres per minute)
Up to 25kg per metre	350mm, 400mm, 450mm, 550mm, 700mm and 850mm	12 / 15 / 19 / 24 / 30

- For inside track width add 62mm to belt width.
- Other configurations available.



# 5

## Gravity Conveyor

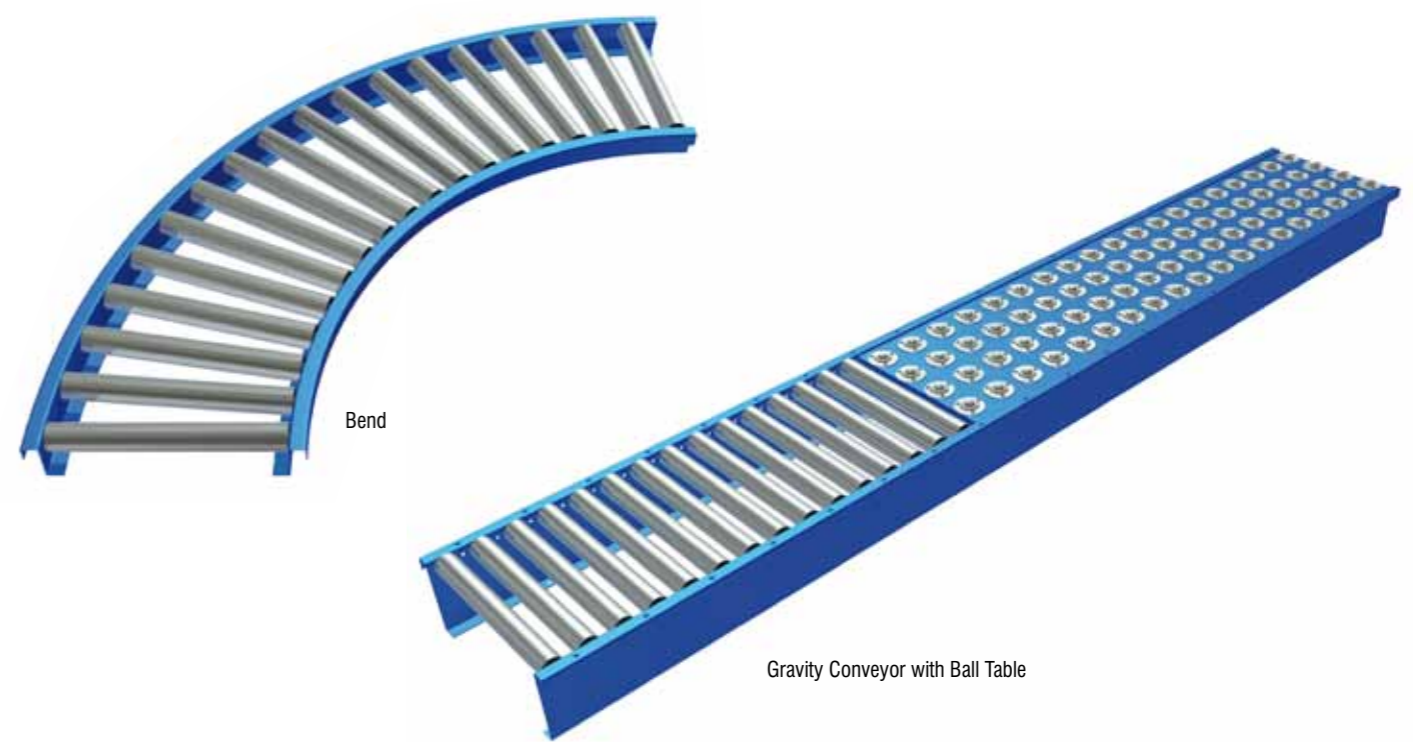
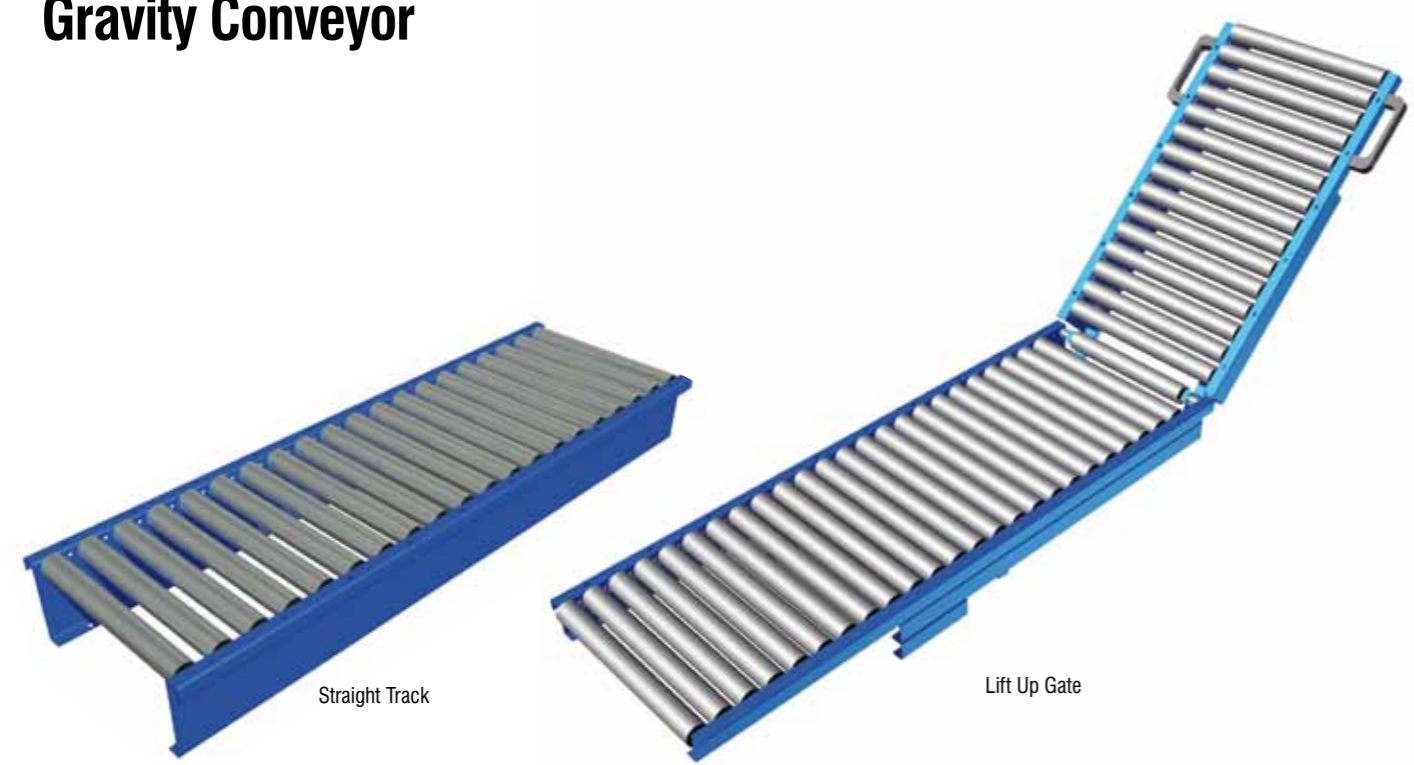

• The most cost-effective conveying solution.

Key Features	Benefits
Modular design.	Proven product, highly configurable, easy and reduced installation with low maintenance. Allows for a variety of arrangements to be made from standard components.
Steel zinc plated rollers.	Surface protection.
Ball table.	Allows for product rotation.
Frames are multi-punched.	Allows for reconfigurable roller pitch for different sized products.

### Ancillary modules include:

- Lift Up Gates
- Skatewheel Bends
- Ball Tables
- Mobile Units
- Turntables

### Available in:

- Powder coated as standard
- Aluminium
- Stainless steel

Model	Static Load Per Roller	Roller Diameter	Roller Pitch	Inside Track Widths	Height from bottom of frame to top of roller
ZTL PC1	20kg	35mm	37.5mm, 75mm, 112.5mm and 150mm	312 – 762mm (in 50mm increments)	'Z' 69mm
ZTL PF1	30kg	50mm	75mm, 112.5mm and 150mm	312 – 762mm (in 50mm increments)	'Z' 76mm
ZTM PN1	45kg	50mm	60mm, 90mm, 120mm and 150mm	312 – 1012mm (in 50mm increments)	'Z' 83mm
CTH NE4	100kg	50mm	75mm, 100mm and 150mm	312 – 1012mm (in 50mm increments)	'C' 106mm
CTH M60	150kg	60mm	75mm, 100mm and 150mm	312 – 1012mm (in 50mm increments)	'C' 111mm
XU60	30kg	50mm	75mm, 100mm and 150mm	312 – 1012mm (in 50mm increments)	'Z' 183mm

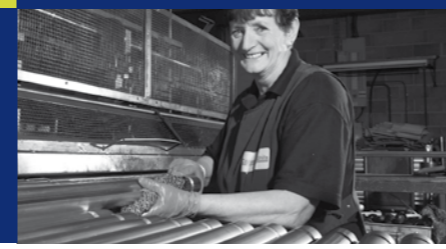

# 6

## Belt Under Roller Conveyor



Straight Track



Belt Transfer



Switch Sorter

- Versatility of transporting or accumulating with the option to upgrade from one to the other.
- Can achieve exceptionally high throughput rates.

Key Features	Benefits
Modular design.	Proven product, highly configurable, easy and reduced installation with low maintenance. Allows for a variety of arrangements to be made from standard components.
Integral photocells.	Quicker installation and wiring. Reduced costs.
Ability to transport or accumulate with the option to upgrade from one to the other.	Increased capacity of your conveyor system.
Buffering of totes and cartons WITH contact between products, but WITHOUT line pressure.	Offers maximum system throughput rates.
High speed.	Faster, higher throughputs.
Quiet.	Reduced noise is more conducive to good working environment.
Multi-functional.	Conveying or accumulating.

**Ancillary modules include:**  
 Stops  
 Line Brakes  
 Switch Sorter  
 Belt Transfer

**Available in:**  
 Powder coated as standard  
 Aluminium  
 Stainless steel

Specification				
Drive Capacity Per Roller	Roller Diameter	Roller Pitch	Standard Track Widths	Standard Speeds (metres per minute)
8kg	50mm	75mm, 100mm and 150mm	412mm 462mm 512mm 612mm 762mm 912mm	12 / 15 / 18 / 25 / 29 / 43 / 49 / 55 / 69 / 86 / 107

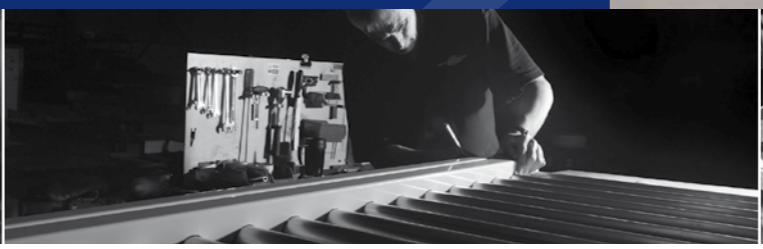
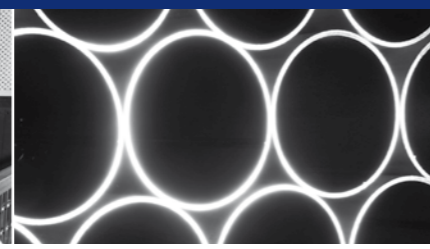



# 7 Flexible Conveyor



Flexible - Expanded / Compacted



Powered Roller



Gravity Roller



Gravity Skatewheel

- Powered and Gravity Options.
- For increased efficiency in loose loading and unloading of vehicles.

Key Features - Powered	Key Features - Gravity	Benefits
AC motor.	-	Low maintenance – no brush wear.
Reinforced, ribbed zinc plated steel side plates.	Reinforced, ribbed zinc plated steel side plates.	Additional strength and total stability.
Structural support across width.	Structural support across width.	Withstand rigorous demands.
Heavy duty square tubing legs.	Heavy duty square tubing legs.	
Fully bolted design without rivets.	Fully bolted design without rivets.	
Roller retaining tag washers.	Roller retaining tag washers.	
Available up to 25m / compacts to a 1/3 of its size when not in use.	Available up to 25m / compacts to a 1/3 of its size when not in use.	Easier to store, takes up minimum space.
Braked, swivel castors.	Braked, swivel castors.	Flexible and easily manoeuvrable.
Flat form cable.	-	Maintains correct cable routing.
Start / Stop buttons at both ends.	-	Safety.
Self tracking – cartons follow twist of conveyor.	Self tracking – cartons follow twist of conveyor.	No need for engineered curves.
Adjustable height.	Adjustable height.	Versatility for different applications.
Smart optics / package stops.	Package stops.	Prevents product damage.

**Ancillary modules include:**  
 Heavy Duty Impact Carts  
 Roller Connecting Brackets  
 Package Stops

Specification				
Type	Load	Conveyor Widths	Roller Diameter	Standard Speeds (metres per minute)
Powered Roller	150kg per linear metre*	450mm, 600mm, 750mm or 900mm	40mm	10-40 variable
Gravity Roller	250kg per linear metre*	450mm, 600mm, 750mm or 900mm	40mm	n/a
Gravity Skatewheel	300kg per linear metre*	450mm, 600mm, 750mm or 900mm	Skatewheel 49mm	n/a

\* Based on level working height.



# Rollers



# Spares



## Optimise Your Operating Efficiency with our Rollers and Parts Service Guarantee

We have also gained a reputation for supplying high quality competitively priced rollers and spares to all aspects of the material handling industry. Our products are used by blue-chip companies in the UK and throughout Europe.

We have a high degree of standardisation in our systems which means we can guarantee a particularly rapid and reliable spare parts service to meet the end-users' needs with speed and ease.

Furthermore, by buying replacement parts from the original equipment manufacturer you are helping to ensure that the equipment stays in prime condition, optimizing the operating efficiency of your system.

## Rollers

We are not only the largest conveyor manufacturer in the UK, but also the largest roller manufacturer, producing in excess of half a million rollers every year.

We source and purchase only the best raw materials directly from the mills, and in vast quantities - in excess of 200km of 50mm diameter steel tubing every year. This means that not only does it allow us to constantly meet order commitments, but it also makes our pricing extremely competitive.

Our range of rollers includes: Gravity Rollers, Plastic Rollers, Stainless Steel Rollers, Grooved Rollers, Tapered Rollers, Sprocketed Rollers, Belt Conveyor Rollers, as well as an extensive range of specialised rollers.

## Spares

We also produce an extensive range of stock components, again competitively priced, for Powered Roller Conveyors, Pallet Conveyors, Gravity Conveyors and Belt Conveyors, with all plastic conveyor components injection moulded here on site.

Please give us the opportunity to quote all your roller and spares requirements.

We can guarantee: -

- Competitive prices.
- Fast turnaround.
- Extensive product range.
- Excellent customer service.



## STOURPORT SITE

- 1 Goods Inwards
- 2 Made To Order Roller Department
- 3 Injection Moulding
- 4 Heavy Duty Drum / Roller Assembly
- 5 Press / Laser Processing Department
- 6 Aluminium Conveyor Assembly
- 7 Heathfield Road
- 8 Sandy Lane
- 9 Product Development
- 10 Tapered Roller Assembly
- 11 Pallet Conveyor Assembly
- 12 Belt Conveyor Assembly
- 13 General Assembly
- 14 Powder Coating Plant / Curing Oven
- 15 Production Welding
- 16 Main Reception
- 17 Despatch
- 18 Ancillary Assembly
- 19 Bend Fabrication
- 20 Press Brake



### 21 Stourport Showroom and Demonstration Area

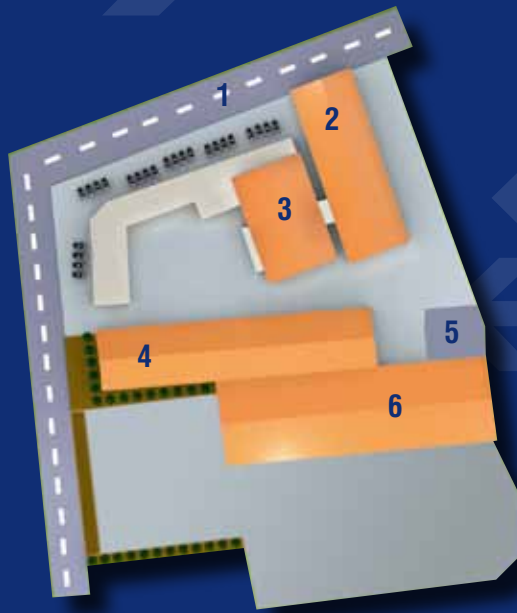

## LYE SITE

- 1 Stour Vale Road
- 2 Stores
- 3 Bearing Assembly
- 4 Press Department / Component Manufacture
- 5 Despatch
- 6 Flexible Conveyor Assembly



 conveyor solutions



**CONVEYOR UNITS**  
QUALITY • PERFORMANCE • RELIABILITY