

Background to development

The core is a waste component of every roll of stretch film. It not only adds cost to the product but it also creates environmental issues with waste disposal after the product is used.

All Standard stretch film rolls are currently wound on to cores, as no other alternative exists.

Championing the supply of 'fit for purpose' products HoloWrap™ have been looking at ways of developing products that will be ever more efficient and eliminate waste in the final product. This is as a direct response to the demands of both our clients, local councils and national governments. All this has been achieved without any reduction in the quality or usability of the end product.

How to use HoloWrap™ Hand rolls

- 1) Push the dispenser & cup handle into the roll
- 2) Push the cup handle into the other end of the dispenser
- 3) You are now ready to wrap. Without a core!

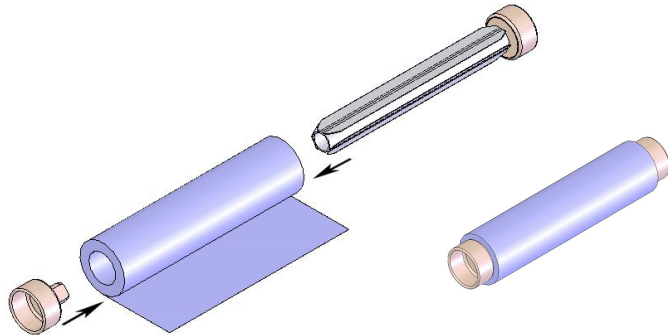

What our customers have to say

'Now we have HoloWrap™, we believe the packaging industry has found what it is looking for.'

'We are convinced that this product, the first of its kind on the market, signals a new system for stretch wrapping which we predict will become common place'

'A good product just got better'

'Not only do I save on waste, I no longer have to worry about finding empty cores on the floor of my warehouse'



HoloWrap™

Stretch film that won't cost the earth!

It is estimated that at least 100 million cardboard tubes need to be disposed of, usually by landfill, every year.

That's a staggering 20,000 tonnes

or

9,500,000 cubic metres of space!

By using HoloWrap™ this can be avoided.

Reasons for development

The new system sets out to:

- Remove the need to dispose of - usually by landfill – some 100 million cardboard tubes per year.
- Cut the amount of waste needing disposal by a staggering 20,000 tonnes or 9,500,000 cubic metres.
- Reduce shipping/ storage volume by 25%
- Reduce or completely eliminate Packaging Waste Levy
- Reduce or completely eliminate disposal costs



HoloWrap™ also offers:

- Usability in both wet and dry conditions
- Easy application
- Available in Hand or Mini Roll formats
- Reduced environmental costs
- No cores to dispose of after use
- Reduced overall cost of the product
- Reduced storage space due to smaller product and packaging
- Excellent performance
- Environmentally friendly. 100% useable

HoloWrap™ is available as both:

Hand rolls

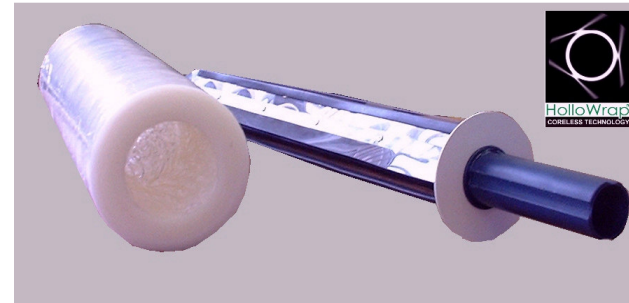

And

Mini-Rolls



HoloWrap™ is a trademarked product, produced on a patented system, which is the environmental replacement for stretch film on a core.

This unique product is not wound on to a core and yet it is used in exactly the same way, without any reduction in performance

Why not Change for the better!	
Please quote me for:	
_____	boxes of HoloWrap™ Hand rolls (6 rolls per box)
_____	boxes of HoloWrap™ Mini rolls (24 rolls per box)
_____	dispensers for HoloWrap™ Hand rolls / Mini rolls (delete as appropriate)
Name _____	Company _____
Contact details _____	

e-mail sales@hollowrap.com