

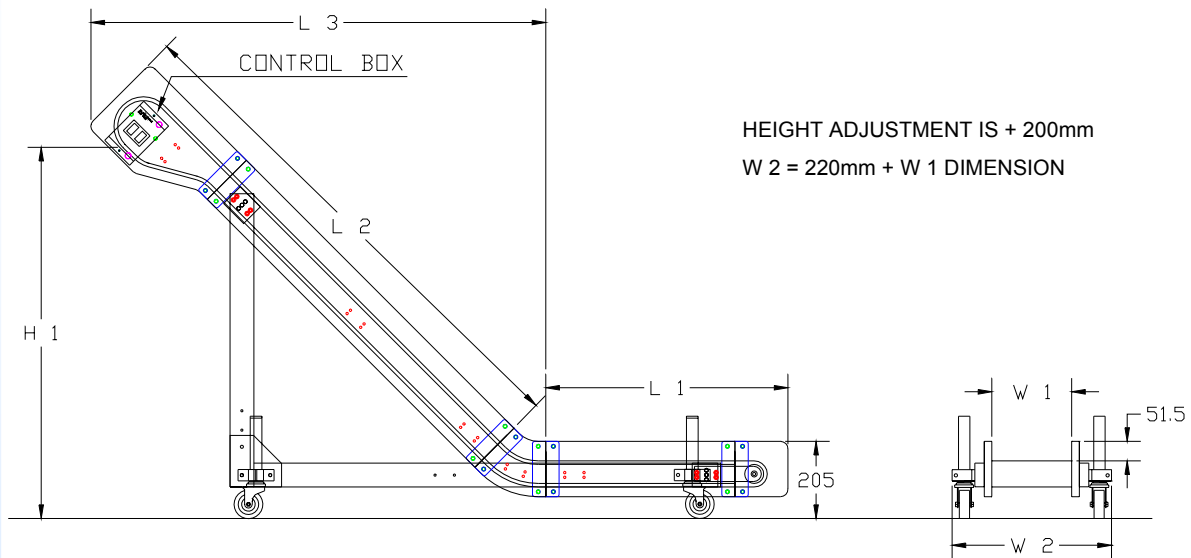

A-SERIES CONVEYOR

- The new UPM belt conveyor has a precision machined belt track with minimum joints ensuring smooth product flow without hold up points or ingress of product into the track.
- The drive system incorporates a large diameter sprocket ensuring maximum drive efficiency with minimum gap around the radius.
- The inlet and outlet of the track are reduced in height to keep a slim line profile down to the feed end to ensure the conveyor can fit under the machine allowing maximum clearance for product movement.
- The conveyor construction allows simple modification to the length or shape in lengths of 0.5, 1, 1.5, 2, 2.5 and 3M sections.
- The conveyor side frames are HMWPE which is durable, tough and fully suited to operation in an industrial environment. Mounted in a purpose designed aluminium profile frame on heavy duty lockable castors.
- As with all UPM conveyor systems the link belt does not require tensioning or tracking.
- The polypropylene link belt is impervious to oil, water and able to operate with product temperature of 104 oC.

A-SERIES CONVEYOR



		DIMENSION	DIMENSION	DIMENSION	DIMENSION	DIMENSION	DIMENSION	DIMENSION	DIMENSION	DIMENSION	DIMENSION	DIMENSION	DIMENSION
		L1 = 640	L1 = 1140	L1 = 1640	L1 = 2140	L1 = 640	L1 = 1140	L1 = 1640	L1 = 2140	L1 = 640	L1 = 1140	L1 = 1640	L1 = 2140
		L2 = 860	L2 = 860	L2 = 860	L2 = 860	L2 = 1360	L2 = 1360	L2 = 1360	L2 = 1360	L2 = 1860	L2 = 1860	L2 = 1860	L2 = 1860
		L3 = 849	L3 = 849	L3 = 849	L3 = 849	L3 = 1202	L3 = 1202	L3 = 1202	L3 = 1202	L3 = 1556	L3 = 1556	L3 = 1556	L3 = 1556
W1 =		H1 = 635	H1 = 635	H1 = 635	H1 = 635	H1 = 980	H1 = 980	H1 = 980	H1 = 980	H1 = 1335	H1 = 1335	H1 = 1335	H1 = 1335
211	MODEL	A4520-1	A4520-2	A4520-3	A4520-4	A4520-5	A4520-6	A4520-7	A4520-8	A4520-9	A4520-10	A4520-11	A4520-12
249	MODEL	A4525-1	A4525-2	A4525-3	A4525-4	A4525-5	A4525-6	A4525-7	A4525-8	A4525-9	A4525-10	A4525-11	A4525-12
288	MODEL	A4530-1	A4530-2	A4530-3	A4530-4	A4530-5	A4530-6	A4530-7	A4530-8	A4530-9	A4530-10	A4530-11	A4530-12
364	MODEL	A4535-1	A4535-2	A4535-3	A4535-4	A4535-5	A4535-6	A4535-7	A4535-8	A4535-9	A4535-10	A4535-11	A4535-12
403	MODEL	A4540-1	A4540-2	A4540-3	A4540-4	A4540-5	A4540-6	A4540-7	A4540-8	A4540-9	A4540-10	A4540-11	A4540-12
444	MODEL	A4545-1	A4545-2	A4545-3	A4545-4	A4545-5	A4545-6	A4545-7	A4545-8	A4545-9	A4545-10	A4545-11	A4545-12
499	MODEL	A4550-1	A4550-2	A4550-3	A4550-4	A4550-5	A4550-6	A4550-7	A4550-8	A4550-9	A4550-10	A4550-11	A4550-12

TECHNICAL DATA

- Conveyor sides grey HMWPE.
- Conveyor belts grey PP 104°C temperature.
- Internal direct drive system.
- Standard motor speed 4.5m / minute.
- Conveyor width <211mm 25w 80mm motor.
- Conveyor width >249mm 40w 90mm motor.
- 3ph 400v 50hz power supply.
- Control manual motor starter IP55.

OPTIONS AVAILABLE UPON REQUEST

- Fixed speed motors 1— 9m/min.
- Fixed speed motors 1PH 240V 50Hz
- Variable speed Inverter 1PH 240v.
- Machine interface controls.
- Belt colours Blue, White & Black PP.
- Belt flights 25mm, 50mm & 76mm.
- External high torque IP67 motors

UPM MACHINERY SALES LTD
LANGLEY BUSINESS PARK
BERKSHIRE
ENGLAND
SL3 6EP

Tel: 00 44 (0) 1753 548801
Fax: 00 44 (0) 1753 544115
Email: sales@upm.co.uk
Website: www.upm.co.uk